



GCSE

3300U60-1

WEDNESDAY, 16 NOVEMBER 2022 – MORNING

MATHEMATICS

UNIT 2: CALCULATOR – ALLOWED

HIGHER TIER

**1 hour 45 minutes plus your additional
time allowance**

**A CALCULATOR WILL BE REQUIRED
FOR THIS EXAMINATION**

Surname: _____

First name(s): _____

Centre Number: _____

Candidate Number: 0 _____

For Examiner's use only

Question	Maximum Mark	Mark Awarded
1.	4	
2.	4	
3.	5	
4.	9	
5.	3	
6.	3	
7.	2	
8.	5	
9.	4	
10.	4	
11.	3	
12.	3	
13.	4	
14.	4	
15.	1	
16.	3	
17.	1	
18.	5	
19.	5	
20.	8	
Total	80	

(Turn over)

ADDITIONAL MATERIALS

A ruler, a protractor and a pair of compasses may be required.

ITEMS INCLUDED WITH QUESTION PAPER

A separate Formula Booklet.

A separate Diagram Booklet.

Models for Question 1 and Question 11.

The Diagram Booklet MUST be handed in to the invigilators and sent for marking.

(Turn over)

INSTRUCTIONS TO CANDIDATES

Use black ink, black ball – point pen, black felt tip or your usual method.

Write your name, centre number and candidate number in the spaces on the front cover.

Answer ALL questions.

Write your answers in the spaces provided.

If you run out of space, use the additional page(s) at the back of the booklet. Question numbers must be given for the work written on the additional page(s).

Take π as 3.14 or use the π button on your calculator.

(Turn over)

INFORMATION FOR CANDIDATES

You should give details of your method of solution when appropriate.

Unless stated, diagrams are not drawn to scale.

Scale drawing solutions will not be acceptable where you are asked to calculate.

The number of marks is given in brackets at the end of each question or part – question.

In question 4, the assessment will take into account the quality of your organisation, communication and accuracy in writing.

(Turn over)

- 1. Ask for the model for Question 1.
The model is NOT made to scale.
The model represents a metal
cylinder.**

**The solid metal cylinder has
a radius of 2.3 cm and a height
of 5 cm.**

The mass of the cylinder is 423.1 g.

Find the density of the metal.

Give your answer in g/cm^3

8

[4 marks]

(Turn over)

2. A solution to the equation

$$x^3 + 5x - 8 = 0$$

lies between 1 and 2

Use the method of trial and improvement to find this solution correct to 1 decimal place.

You must show all your working.

(Turn over)

13

[4 marks]

(Turn over)

3. A rectangle has a width of $4x - 10$

(a) Given that x is a whole number, explain why the value of x cannot be less than 3

(Turn over)

[1 mark]

continued on the next page . . .

(Turn over)

Question 3 continued

- 3. (b) Look at the diagram for Question 3 (b) in the separate Diagram Booklet. The diagram is NOT drawn to scale.**
- The diagram shows a rectangle.**
- The perimeter of this rectangle is $14x - 4$**
- The width of the rectangle is $4x - 10$**
- Find the length of the rectangle in TERMS OF x .**
-
-

(Turn over)

18

[4 marks]

(Turn over)

- 4. IN THIS QUESTION, YOU WILL BE ASSESSED ON THE QUALITY OF YOUR ORGANISATION, COMMUNICATION AND ACCURACY IN WRITING.**

Look at the diagram for Question 4 in the separate Diagram Booklet. The diagram is NOT drawn to scale.

A , B and C are points on the circumference of a circle with centre O .

The length of BC is 10 cm.

The diameter of the circle is 18 cm.

Angle ABC is a right angle.

continued on the next page . . .

(Turn over)

Question 4 continued

Calculate the shaded area.

You must show all your working.

(Turn over)

[7 marks + 2 marks OCW]

(Turn over)

5. Look at the diagram for Question 5 in the separate Diagram Booklet. The diagram is NOT drawn to scale.

In the diagram,

$$XZ = 7 \text{ cm}$$

$$\text{Angle } XZY = 41^\circ$$

Angle YXZ is a right angle.

Calculate the length of the side YZ in the triangle XYZ shown.

(Turn over)

6. Two times are recorded correct to the NEAREST 0.1 SECOND.

12.4 seconds
25.5 seconds

Calculate the greatest possible difference between these times.

(Turn over)

[3 marks]

(Turn over)

[2 marks]

(Turn over)

- 8. Look at the diagram for Question 8 in the separate Diagram Booklet. The diagram is an incomplete tree diagram.**

Bag A and Bag B contain only red and blue balls.

The probability of choosing a red ball from Bag A is $\frac{3}{5}$

The probability of choosing a red ball from Bag B is 0.25

A ball is chosen at random from each bag.

continued on the next page . . .

(Turn over)

Question 8 continued

8. (a) Complete the tree diagram.

[2 marks]

(b) Find the probability that the two balls chosen are the same colour.

(Turn over)

[3 marks]

(Turn over)

9. Solve the following simultaneous equations using an algebraic (not graphical) method.

Do not use a trial and improvement method. You must show all your working.

$$3x + 5y = -2$$

$$5x + 4y = -12$$

(Turn over)

[4 marks]

(Turn over)

[3 marks]

continued on the next page . . .

(Turn over)

40

[1 mark]

(Turn over)

11. Ask for the model for Question 11.

The model is NOT made to scale.

**A cone is joined to a hemisphere,
as shown on the model.**

**Look at the diagram for Question 11
in the separate Diagram Booklet.**

The diagram is NOT drawn to scale.

**The diagram is a 2D simplified
diagram of the model.**

**The cone has a base radius of 8 cm
and a slant height of 17 cm.**

**The hemisphere has the same
radius as the cone.**

continued on the next page . . .

(Turn over)

[3 marks]

(Turn over)

12. Solve the equation

$$59x^2 - 7x - 13 = 0$$

Give your answers correct to
2 decimal places.

You must show all your working.

(Turn over)

13. Two similar shapes have perimeters of 241 cm and 719 cm.

The area of the smaller shape is 2063 cm²

Calculate the area of the larger shape. Give your answer in m²

(Turn over)

[4 marks]

(Turn over)

14. Look at the diagram for Question 14 in the separate Diagram Booklet. The diagram is NOT drawn to scale.

DE is the tangent to the circle at point *A*, as shown.

BC = 7 cm and *AC* = 13 cm.

Angle *BAD* = 68° and

angle *CAE* = 80°

continued on the next page . . .

(Turn over)

Question 14 continued

14. (a) Find the size of angle ACB .

**State the angle property you
have used to find your answer.**

[2 marks]

continued on the next page . . .

(Turn over)

Question 14 continued

14. (b) Calculate the area of the triangle *ABC*.

(Turn over)

[2 marks]

(Turn over)

**15. Write down an IRRATIONAL number whose value is between 9 and 10
Write your answer in the box on the next page.**

(Turn over)

Irrational number is:

[1 mark]

(Turn over)

16. Fully factorise the expression

$$k^3p - kp^3$$

(Turn over)

[3 marks]

(Turn over)

17. Look at the diagrams for Question 17 in the separate Diagram Booklet. The diagrams show five different graphs, A, B, C, D and E.

The equation $y = (x - 3)(x - 7)$ describes only ONE of the graphs.

Which graph correctly shows this equation? Circle your answer.

Graph A
Graph B
Graph C
Graph D
Graph E

[1 mark]

(Turn over)

18. The following nine cards are placed in a box.



Catherine chooses THREE cards at random from the box, without replacement.

- (a) Calculate the probability that the three cards drawn show the letters 'A', 'F' and 'O' in that order.**

(Turn over)

[2 marks]

continued on the next page . . .

(Turn over)

Question 18 continued

18. (b) Calculate the probability that two of the three cards show the same letter.

(Turn over)

[3 marks]

(Turn over)

19. Make e the subject of the following formula.

$$c(d + e^2) + f(g - e^2) = h$$

(Turn over)

(Turn over)

[5 marks]

(Turn over)

20. Look at the diagram for Question 20 in the separate Diagram Booklet.

The diagram is NOT drawn to scale.

The diagram shows a triangle ABC and a circle with centre C .

The points B and D lie on the circumference of the circle.

The length of the line AB is 19 cm.

The length of the line AC is 29 cm.

Angle $BAD = 36^\circ$

The radius of the circle is x cm.

continued on the next page . . .

(Turn over)

Question 20 continued

Calculate the area of the shaded sector *BCD*.

(Turn over)

[8 marks]

END OF PAPER

TOTAL 80 MARKS

(Turn over)

Question number	Additional pages, if required. Write the question number(s) in the left - hand margin.

3300U60-1

WEDNESDAY, 16 NOVEMBER 2022 – MORNING

MATHEMATICS

**UNIT 2: CALCULATOR – ALLOWED
HIGHER TIER**

**The Diagram Booklet MUST
be handed in to the invigilators
and sent for marking.**

Diagram Booklet

Surname: _____

First name(s): _____

Centre Number: _____

Candidate Number: 0 _____

Question 3 (b)

Diagram NOT drawn to scale

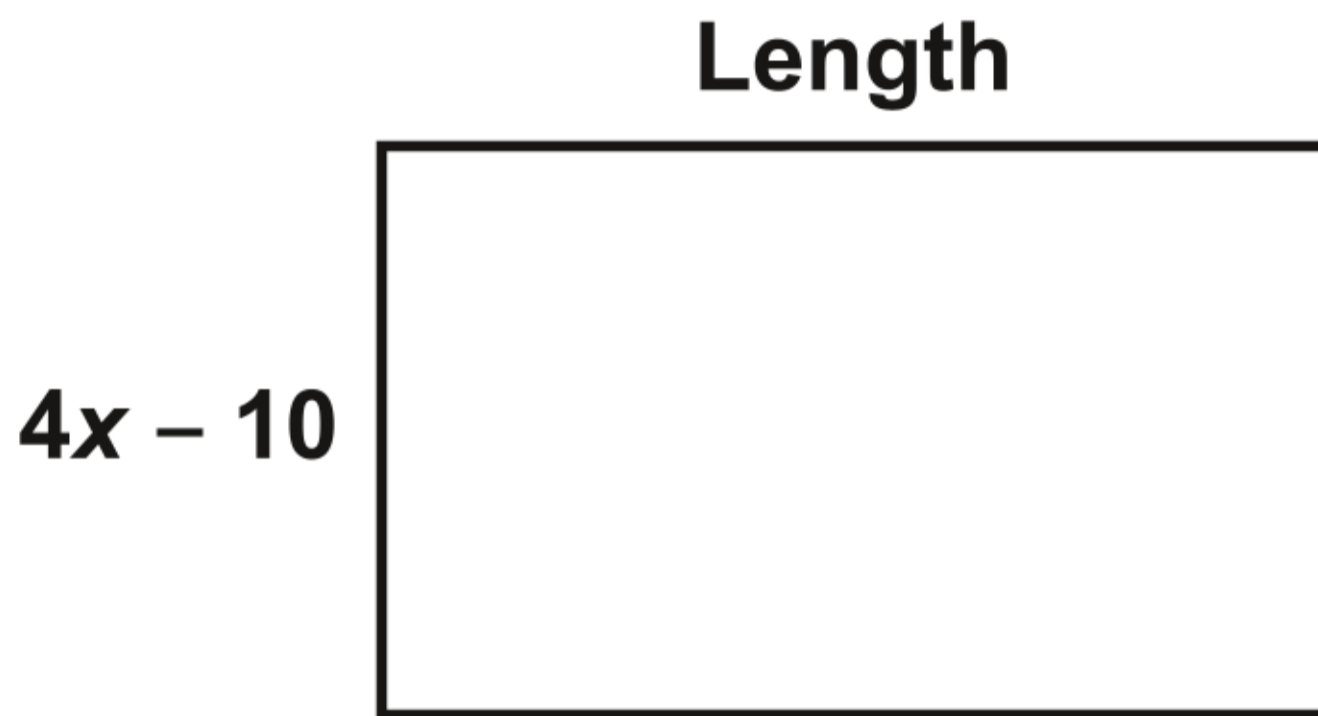

Question 4

Diagram NOT drawn to scale

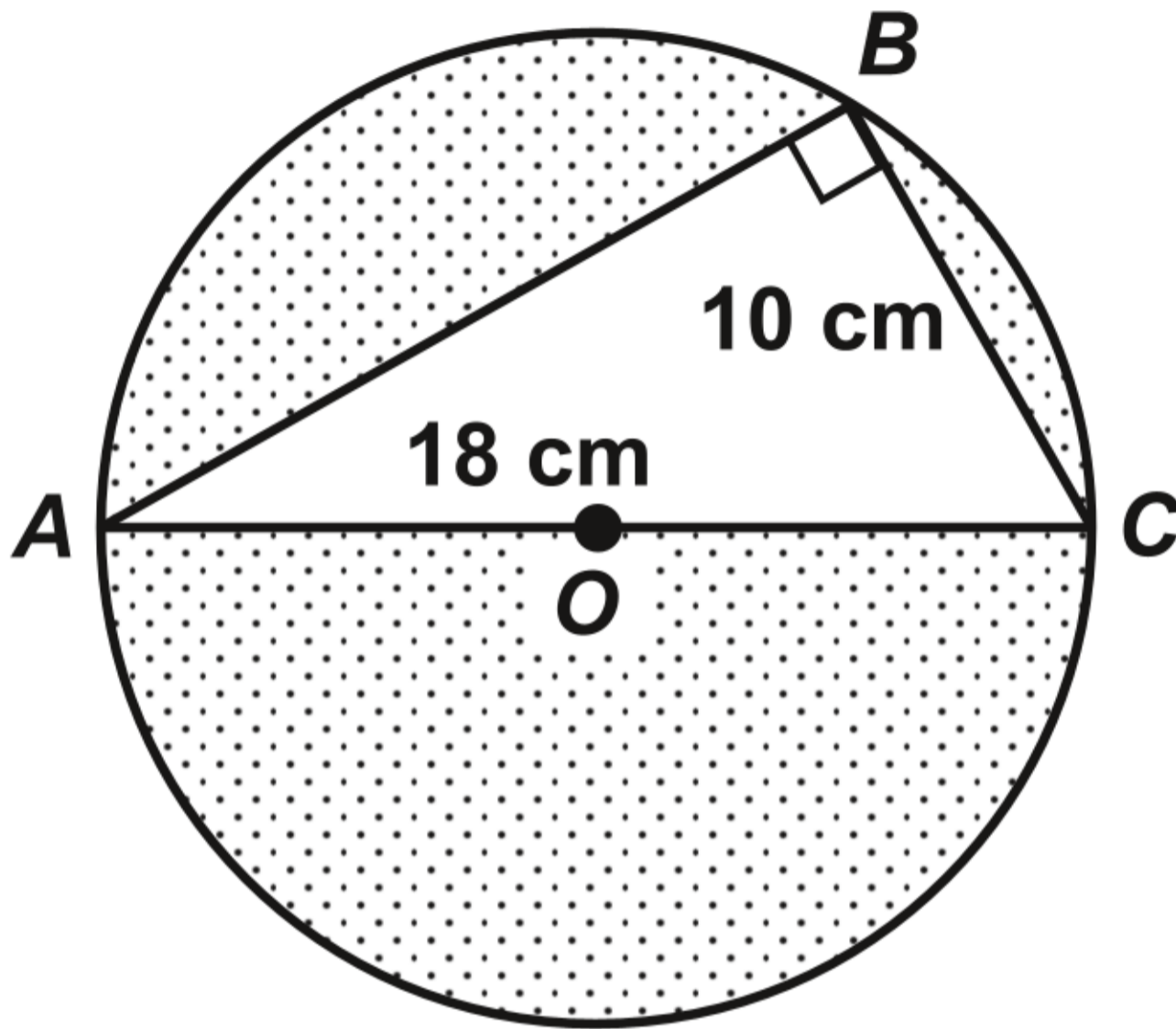

Question 5

Diagram NOT drawn to scale

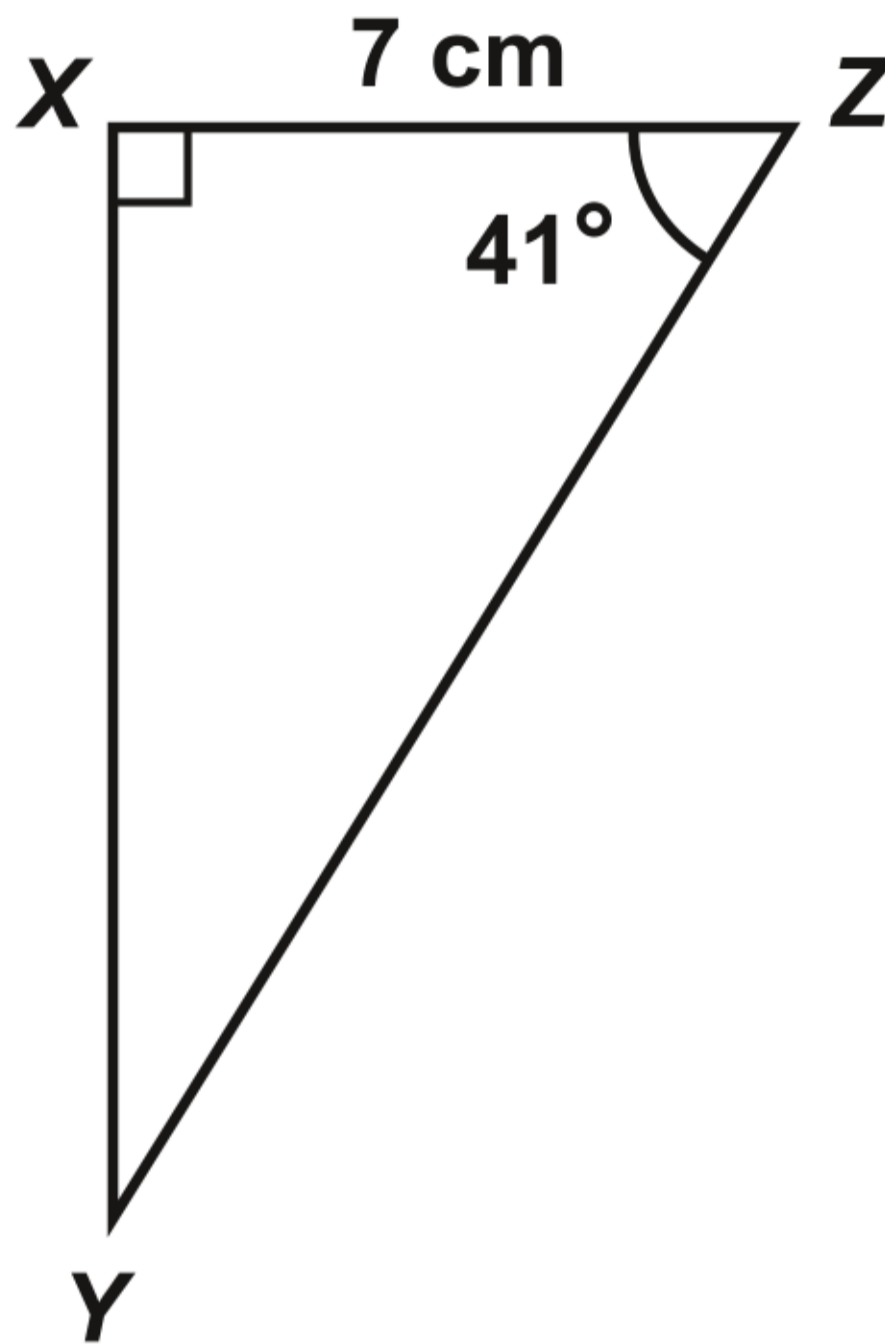

Question 8

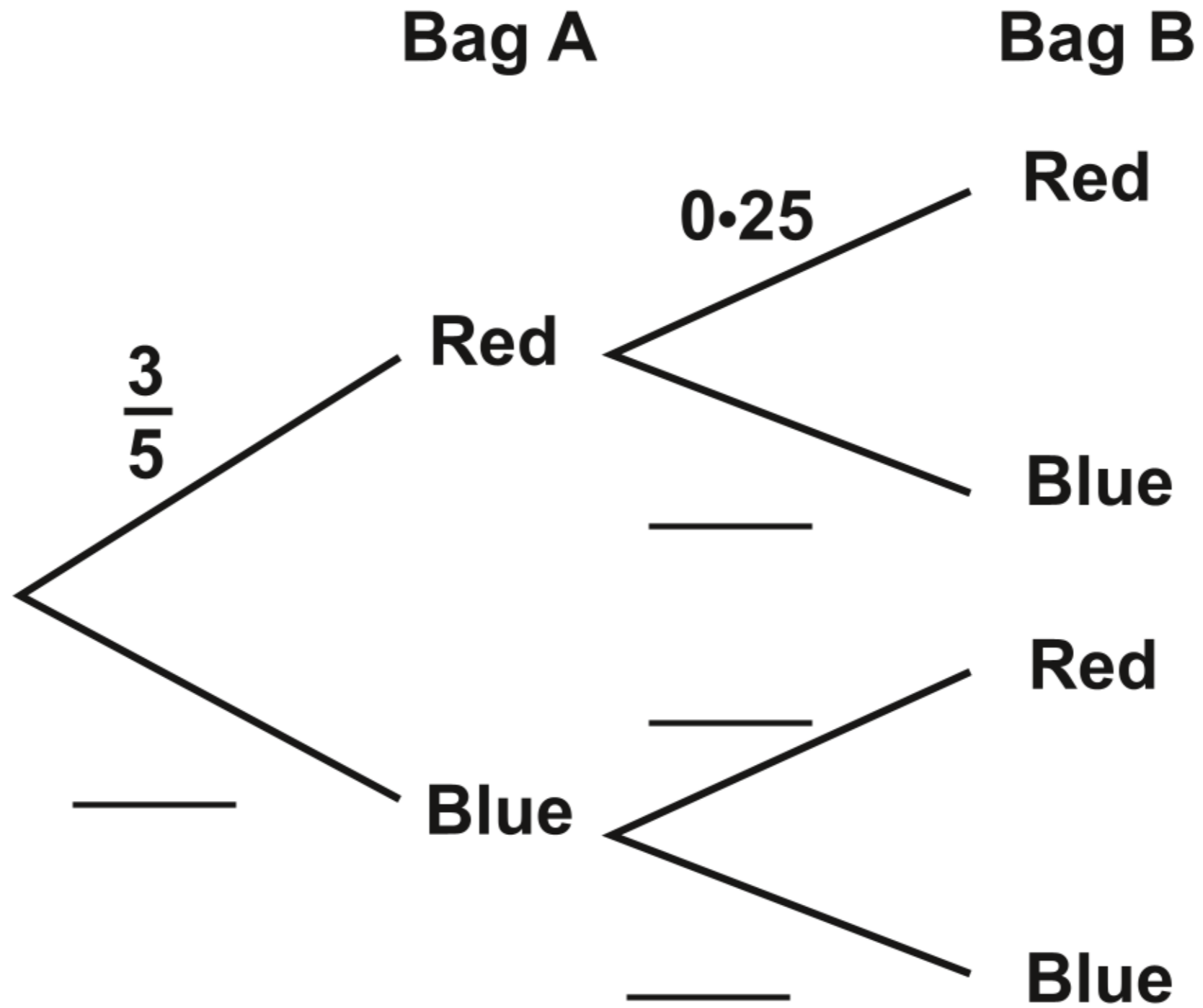

Question 11

Diagram NOT drawn to scale

2D simplified diagram of the model

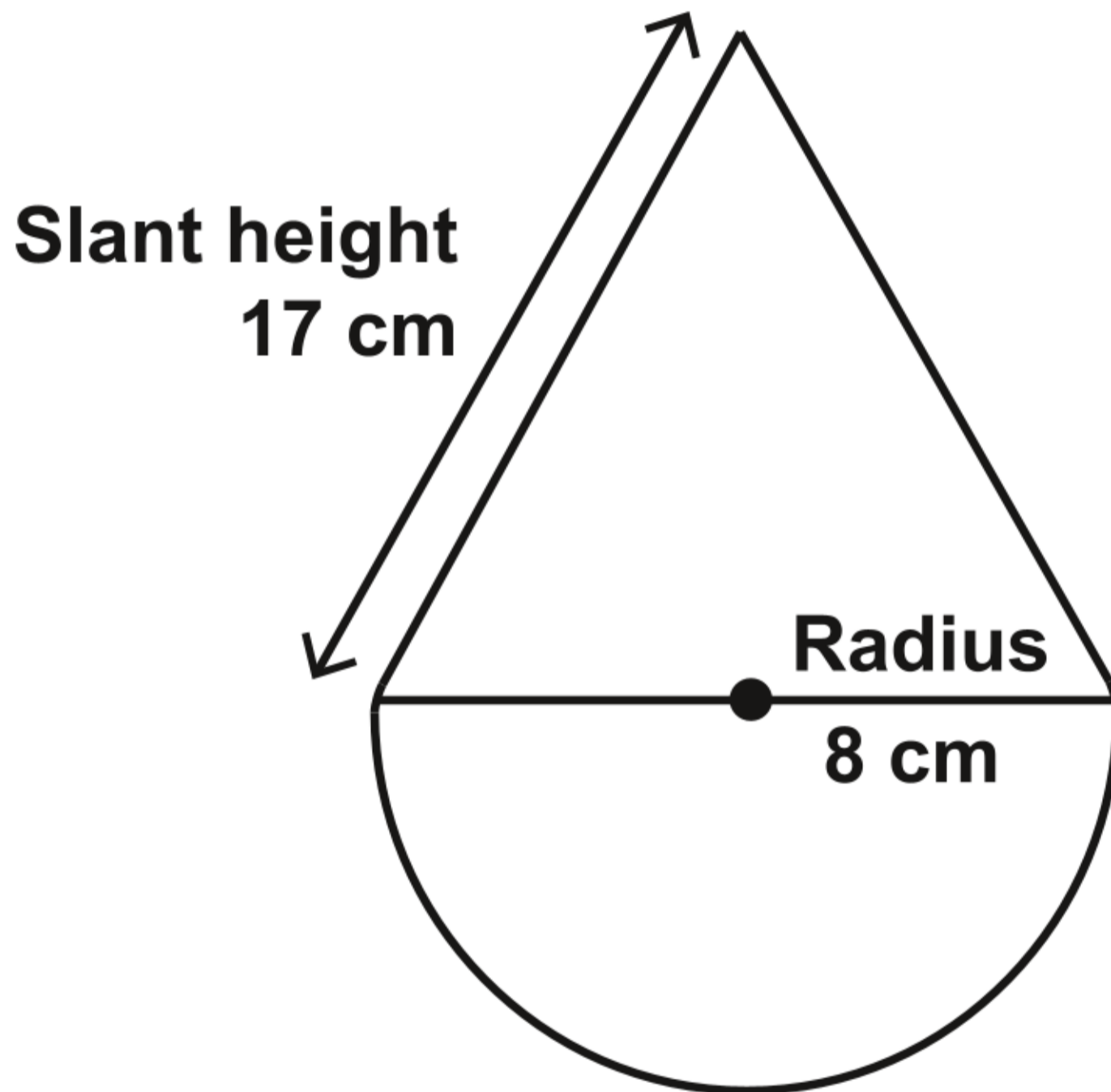

Question 14

Diagram NOT drawn to scale

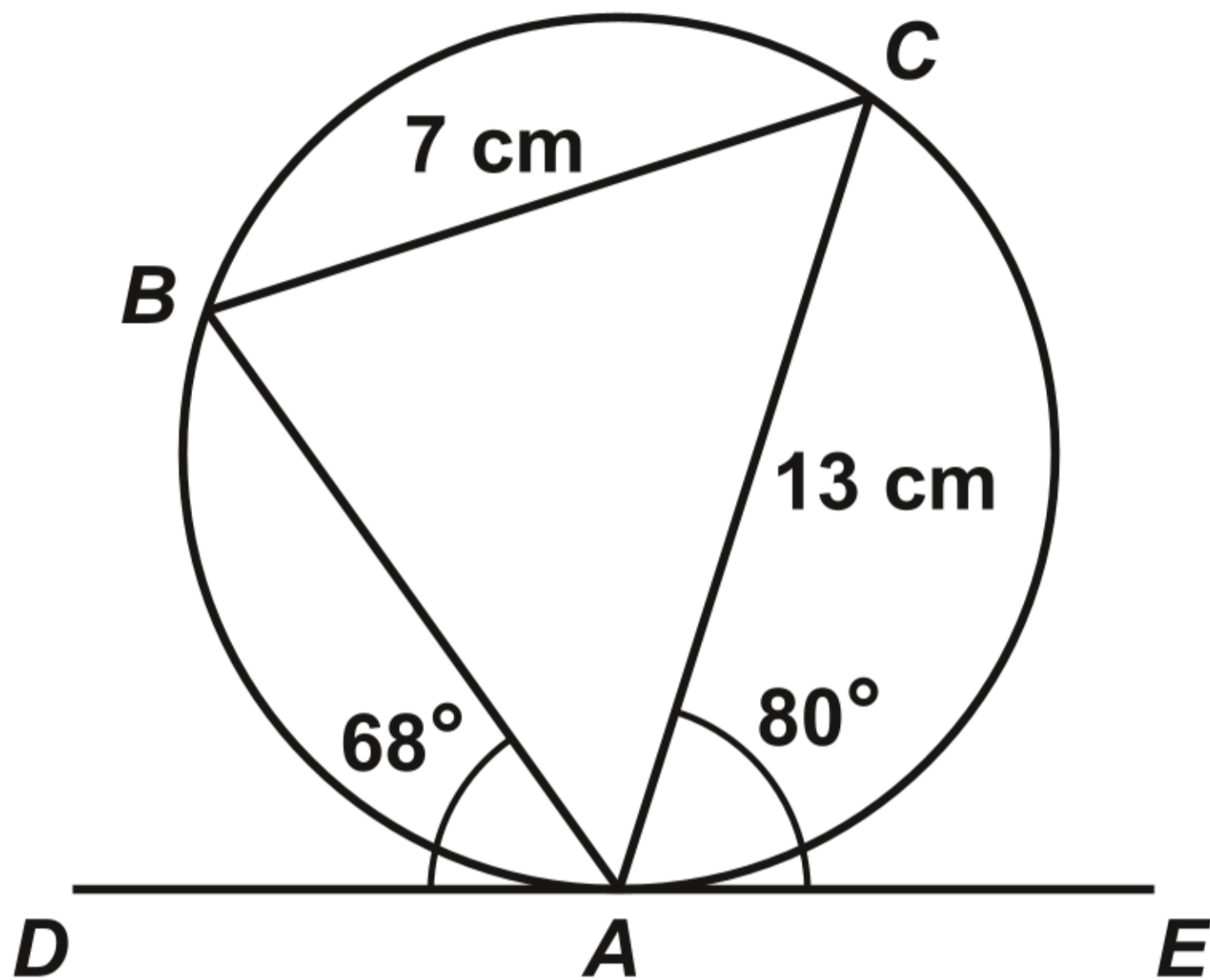

Question 17

Graph A

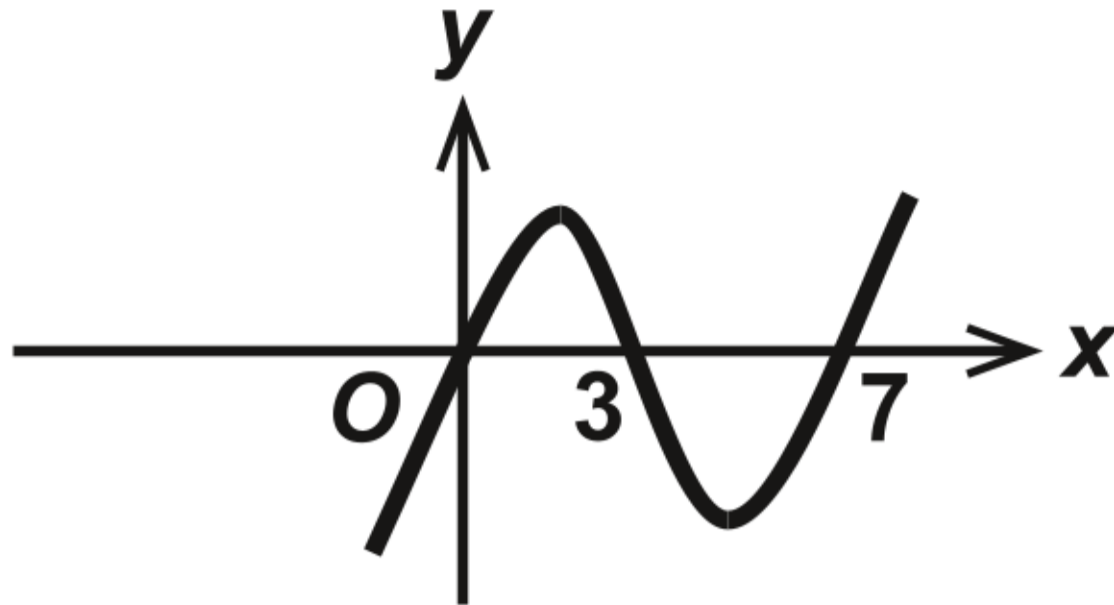

Graph B

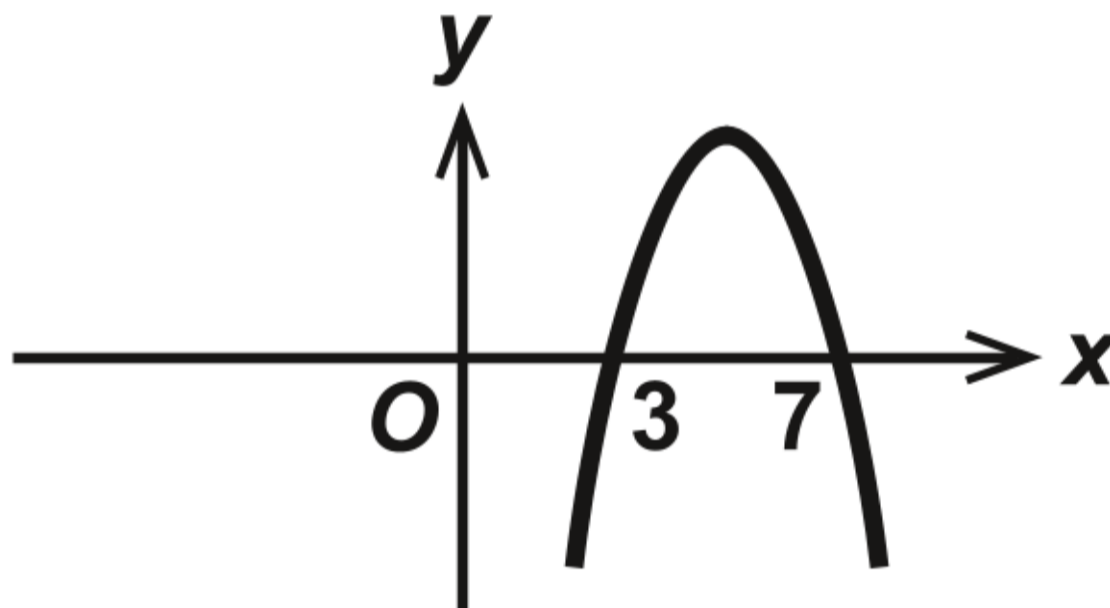

Graph C

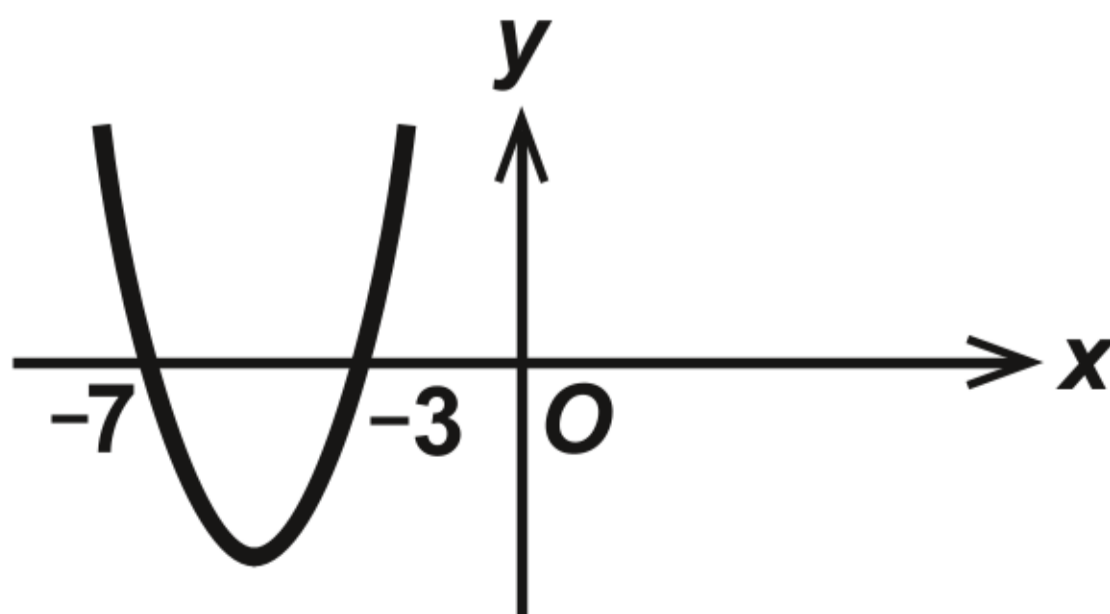

Question 17 continued

Graph D

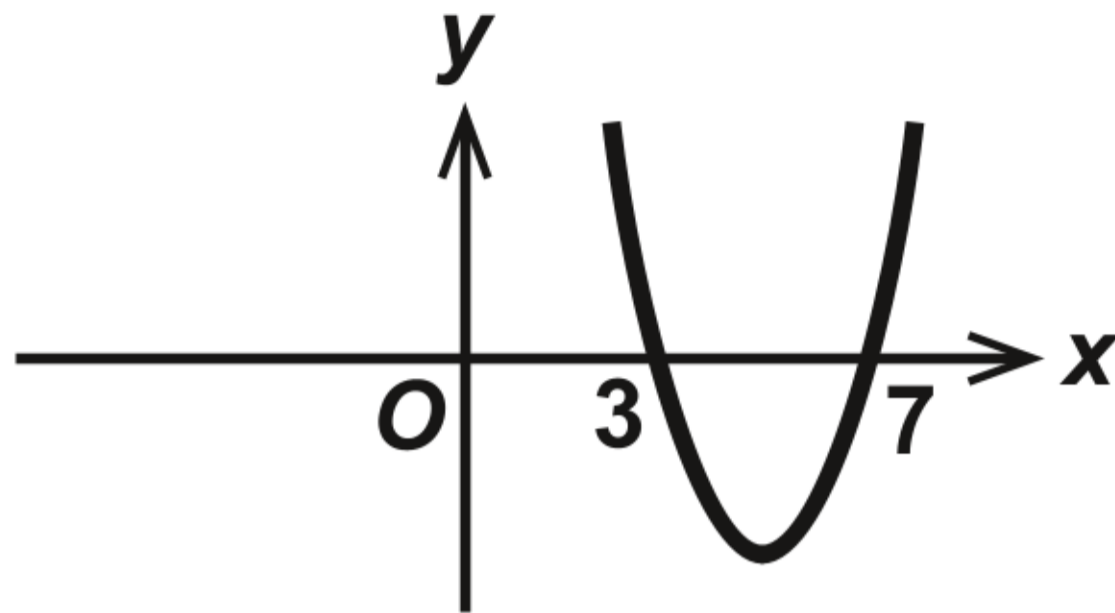

Graph E

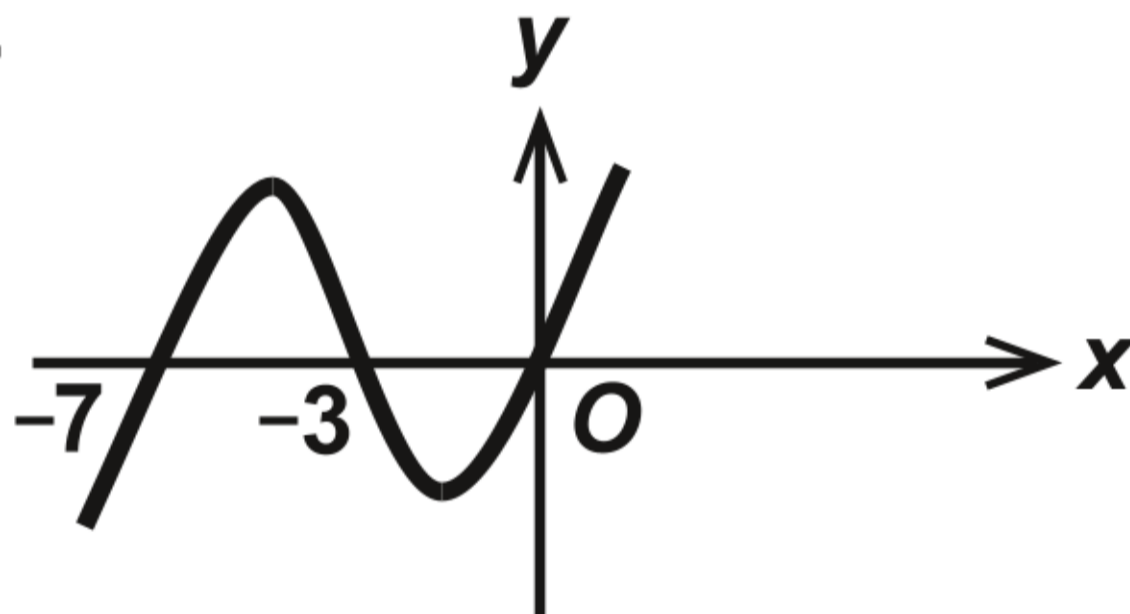

Question 20

Diagram NOT drawn to scale

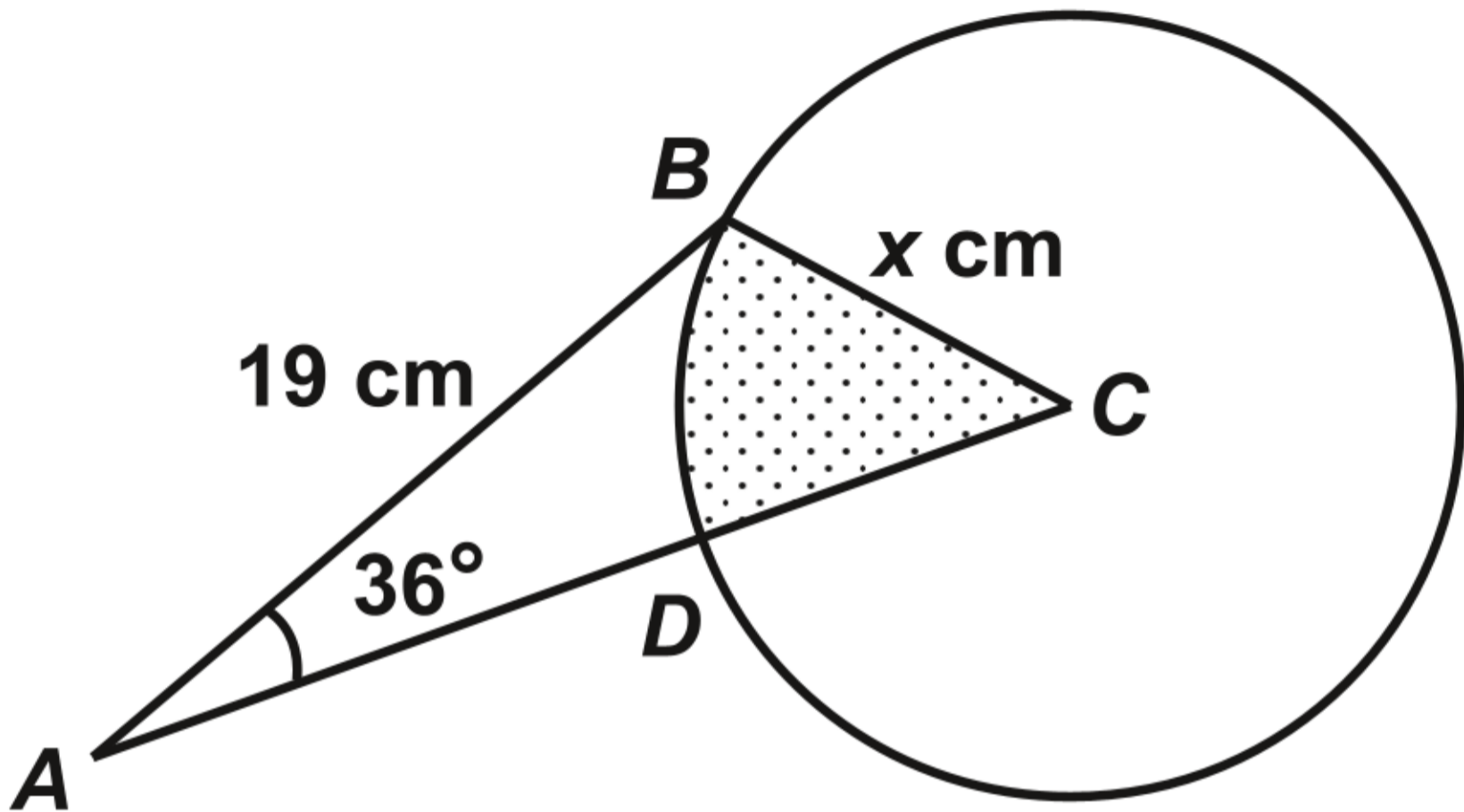

**GCSE
MATHEMATICS
and
NUMERACY**



**FORMULA LIST
HIGHER TIER
GCSE**

You must not write on these formula pages.

Anything you write on these formula pages will gain NO credit.

Formula List – Higher Tier

Area of trapezium $= \frac{1}{2} (a + b) h$

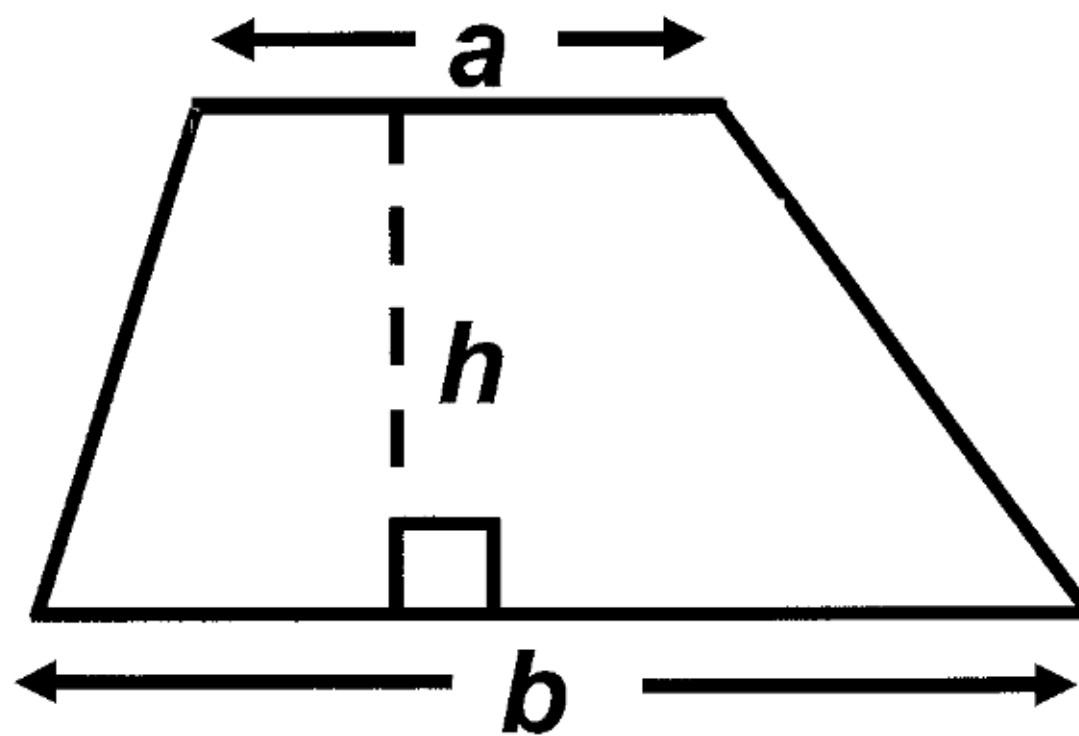

Volume of prism =
area of cross – section \times length

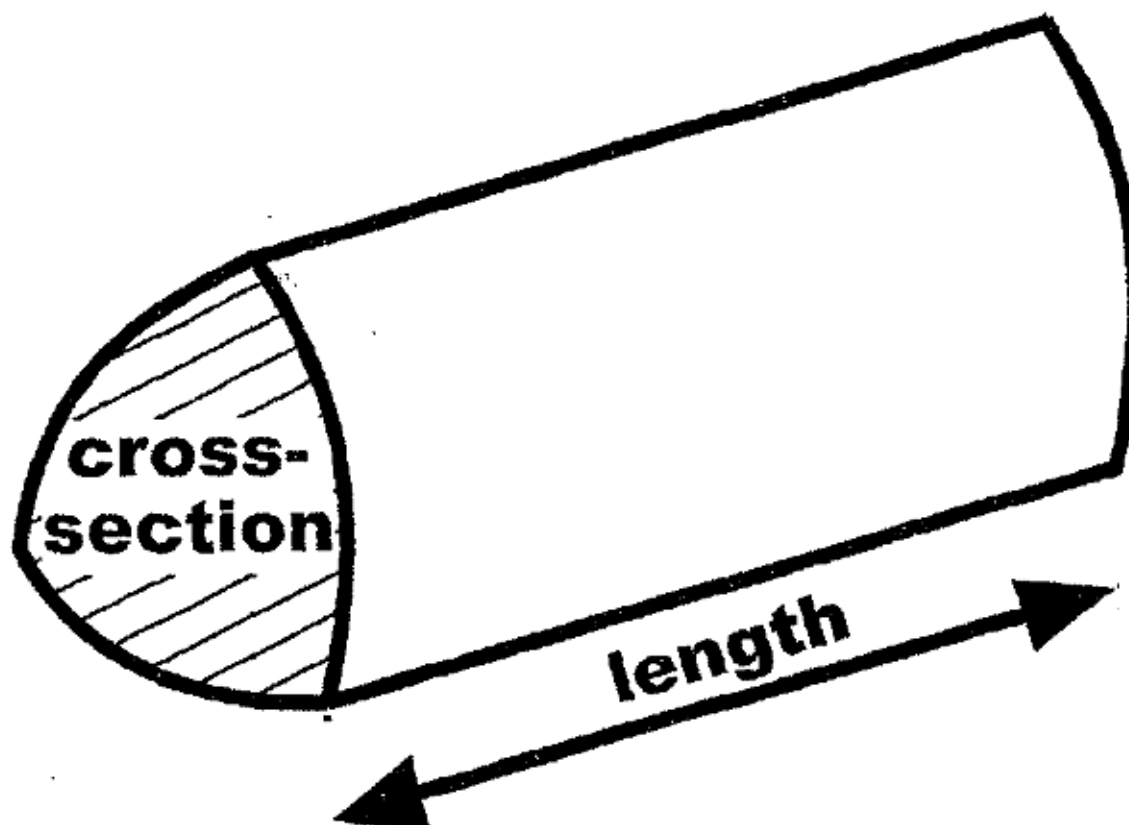

Volume of sphere = $\frac{4}{3}\pi r^3$

Surface area of sphere = $4\pi r^2$

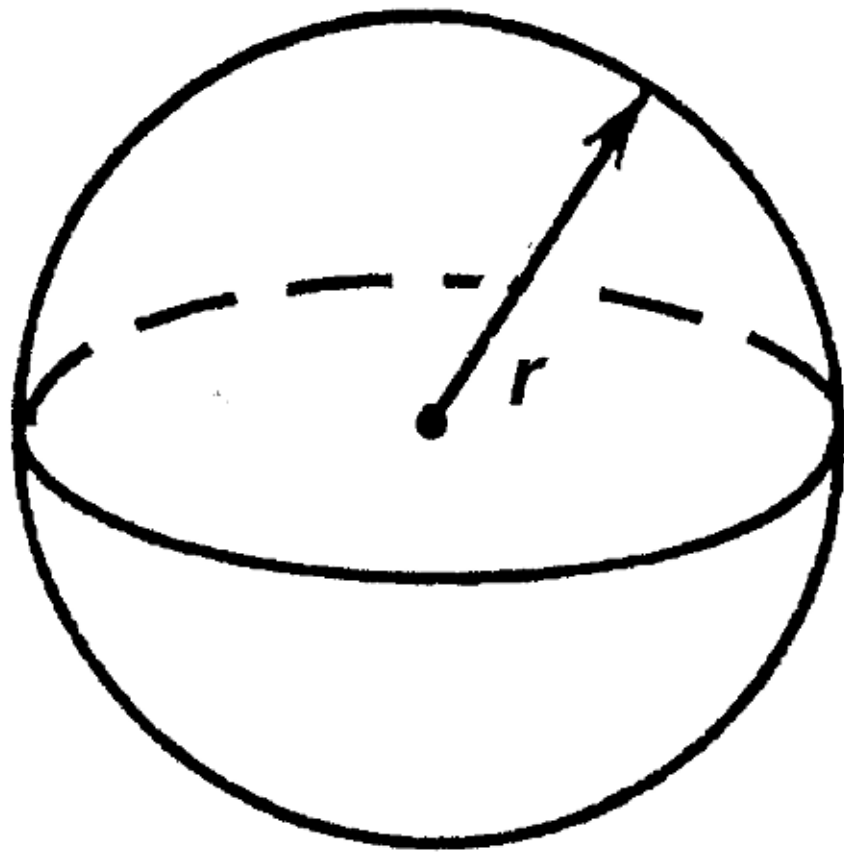

Volume of cone = $\frac{1}{3}\pi r^2 h$

Curved surface area of cone = $\pi r l$

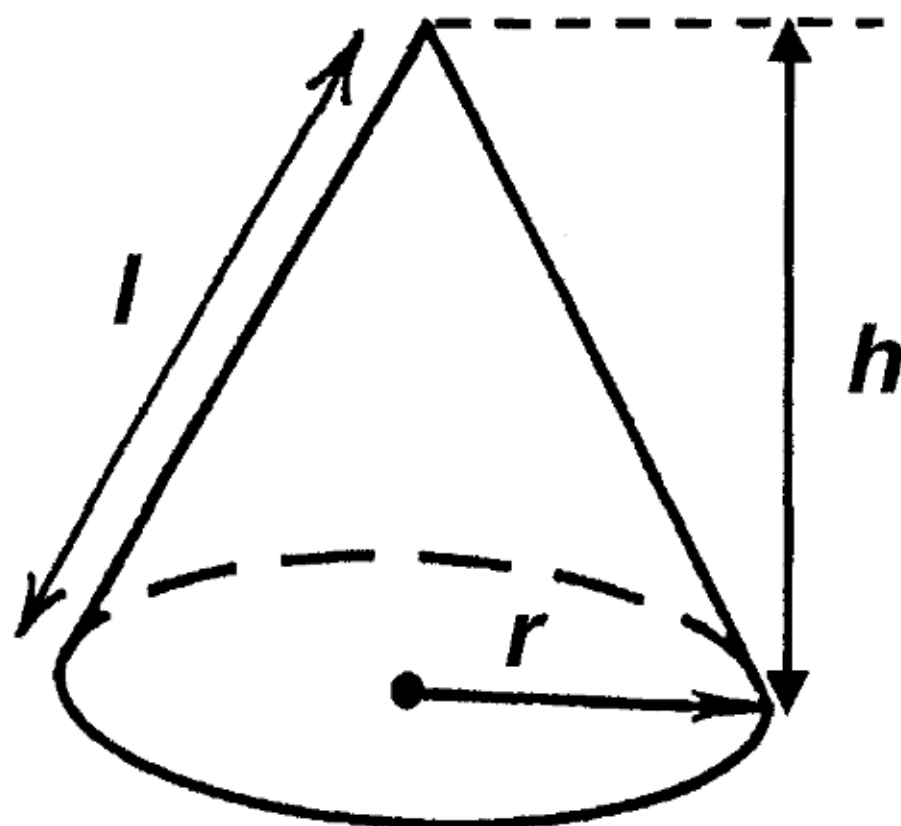

In any triangle ABC

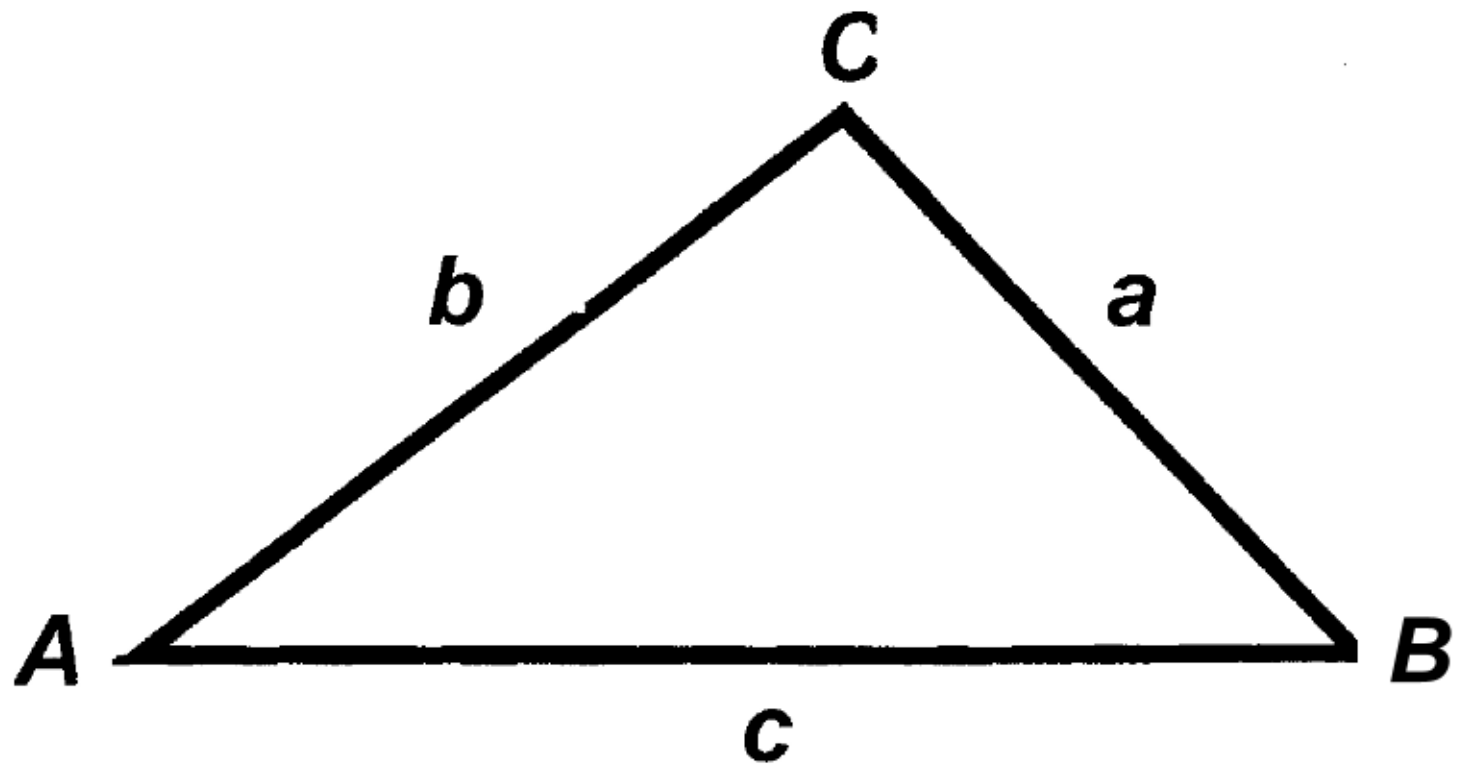

Sine Rule $\frac{a}{\sin A} = \frac{b}{\sin B} = \frac{c}{\sin C}$

Cosine Rule $a^2 = b^2 + c^2 - 2bc \cos A$

Area of triangle $= \frac{1}{2} ab \sin C$

The Quadratic Equation

The solutions of $ax^2 + bx + c = 0$

where $a \neq 0$, are given by

$$x = \frac{-b \pm \sqrt{b^2 - 4ac}}{2a}$$

Annual Equivalent Rate (AER)

AER, as a decimal, is calculated using

the formula $\left(1 + \frac{i}{n}\right)^n - 1$, where i is the

nominal interest rate per annum as a

decimal and n is the number of

compounding periods per annum.