



GCSE

3310U60–1

THURSDAY, 7 NOVEMBER 2024 – MORNING

MATHEMATICS – NUMERACY

UNIT 2: CALCULATOR – ALLOWED

HIGHER TIER

**1 hour 45 minutes plus your additional
time allowance**

**A CALCULATOR WILL BE REQUIRED
FOR THIS PAPER**

Surname: _____

First name(s): _____

Centre Number: _____

Candidate Number: 0 _____

For Examiner's use only		
Question	Maximum Mark	Mark Awarded
1.	8	
2.	16	
3.	8	
4.	10	
5.	7	
6.	7	
7.	7	
8.	17	
Total	80	

ADDITIONAL MATERIALS

A ruler, a protractor and a pair of compasses may be required.

ITEMS INCLUDED WITH QUESTION PAPER

A separate Formula List.

A separate Diagram Booklet.

A model for Question 8 (d).

The Diagram Booklet **MUST be handed in to the invigilators and sent for marking.**

INSTRUCTIONS TO CANDIDATES

Use black ink, black ball – point pen, black felt tip or your usual method.

Write your name, centre number and candidate number in the spaces on the front cover.

Answer ALL questions.

Write your answers in the spaces provided. If you run out of space, use the additional page(s) at the back of this booklet, taking care to number the question(s) correctly.

Take π as $3 \cdot 14$ or use the π button on your calculator.

(Turn over)

INFORMATION FOR CANDIDATES

You should give details of your method of solution when appropriate.

Unless stated, diagrams are not drawn to scale.

Scale drawing solutions will not be acceptable where you are asked to calculate.

The number of marks is given in brackets at the end of each question or part – question.

In question 2 (a) (i), the assessment will take into account the quality of your linguistic and mathematical organisation, communication and accuracy in writing.

(Turn over)

[3 marks]

continued on the next page . . .

(Turn over)

Question 1 continued

- 1. (b) Look at the diagram for Question 1 (b) in the separate Diagram Booklet. The diagram is NOT drawn to scale. The diagram represents a fridge – freezer.**

Steffan is thinking of buying the fridge – freeze shown in the diagram.

The width is 600 mm.

The height is 1800 mm.

Steffan needs to check that the FREEZER compartment of this fridge – freezer has enough room.

continued on the next page . . .

(Turn over)

9

[5 marks]

(Turn over)

2. (a) A small packet contains four Caru chocolate cakes.

The four cakes have a total mass of 84 g.

- (i) IN THIS PART OF THE QUESTION, YOU WILL BE ASSESSED ON THE QUALITY OF YOUR ORGANISATION, COMMUNICATION AND ACCURACY IN WRITING.

The following information is written on the packet:

‘Caru chocolate cakes contain 600 calories per 100 g.’

continued on the next page . . .

(Turn over)

Question 2 (a) (i) continued

Simon aims for a calorie intake of 2400 calories per day.

Today Simon eats ONE Caru chocolate cake.

What percentage of his daily calorie intake is this cake?

You must show all your working.

Question 2 (a) continued

2. (a) (ii) Caru chocolate cakes contain only fat, carbohydrate, protein and salt.

Look at the information for Question 2 (a) (ii) in the separate Diagram Booklet. The information shows a ratio.

How many grams of protein are there in an 84 g packet of four cakes?

Give your answer correct to 2 significant figures.

[3 marks]

continued on the next page . . .

(Turn over)

Question 2 continued

2. (b) Cheryl keeps fit by running every day.

(i) Cheryl burns 690 calories per hour when she runs. Eating a banana gives Cheryl 92 calories of energy.

Cheryl wants to burn off the energy in this banana. For how many minutes would she need to run? You must show all your working.

_____ minutes

[3 marks]

continued on the next page . . .

(Turn over)

- 3. (a) Look at the diagram for Question 3 (a) in the separate Diagram Booklet. The diagram is NOT drawn to scale.**

The base of a flagpole is fixed to horizontal ground.

It is held vertically by a straight rod of length $3 \cdot 8$ metres.

The rod is fixed to the ground and to a point $1 \cdot 5$ metres from the top of the flagpole.

The flagpole and the rod are shown in the diagram.

Calculate the TOTAL height of the flagpole.

Give your answer correct to the nearest centimetre.

Question 3 continued

3. (b) Look at the diagrams for Question 3 (b) in the separate Diagram Booklet. The diagrams are NOT drawn to scale. Mathematically similar large, medium and small flags are shown.

(i) Calculate the length of the medium flag.

Length of the medium flag

is _____ cm

[2 marks]

continued on the next page . . .

(Turn over)

Question 3 (b) continued

3. (b) (ii) Calculate the height of the small flag.

Height of the small flag

is _____ cm

[2 marks]

(Turn over)

4. Aderyn is a company that makes bird feeders.

Squirrels often try to steal food from bird feeders.

To make this more difficult, Aderyn has designed a NEW bird feeder.

Aderyn tests its new feeder to check how long it takes squirrels to reach the food inside.

Look at the diagram for Question 4 in the separate Diagram Booklet.

The diagram is a cumulative frequency diagram.

The results are displayed in this cumulative frequency diagram.

continued on the next page . . .

(Turn over)

Question 4 continued

- 4. (a) Look at the table for Question 4 (a) in the separate Diagram Booklet. Aderyn has this information about the time it took squirrels to reach the food in its ORIGINAL bird feeder.**

Aderyn compared the times squirrels take to reach the food in the original bird feeder and the times they take to reach food in the new bird feeder.

- (i) Complete this sentence:**

‘The modal group for the new bird feeder is between _____ and _____ seconds.’

continued on the next page . . .

(Turn over)

Question 4 (a) (i) continued

Does the modal group for the new bird feeder imply that there is an improvement in the times?

Yes

No

[1 mark]

continued on the next page . . .

(Turn over)

Question 4 (a) continued

4. (a) (ii) Use the cumulative frequency diagram and the table for Question 4 in the Diagram Booklet to give the best estimate to complete each of the following sentences.

I. 'The difference between the median times is _____ seconds.'

[1 mark]

continued on the next page . . .

(Turn over)

Question 4 (a) (ii) continued

4. (a) (ii) II. 'The difference between the interquartile ranges of the times is _____ seconds.'

[2 marks]

continued on the next page . . .

(Turn over)

Question 4 continued

- 4. (b) Use the cumulative frequency diagram for Question 4 in the Diagram Booklet to give the best estimate to complete the following sentence.**

**‘20% of the squirrels took
_____ seconds or
more to reach the food
in the new bird feeder.’**

[3 marks]

continued on the next page . . .

(Turn over)

Question 4 continued

- 4. (c) The population density of grey squirrels in forests depends on the variety of tree that grows there.**

Look at the table for Question 4 (c) in the separate Diagram Booklet.

Rhian says,

“I know that Maesgwyn forest has only one variety of tree: oak, chestnut or pine.”

continued on the next page . . .

(Turn over)

Question 4 (c) continued

Maesgwyn forest covers an area of 21 500 m²

There are 24 grey squirrels living in Maesgwyn forest.

From this information, which variety of tree is most likely to be found in Maesgwyn forest?

You must show working to support your answer.

Oak

Chestnut

Pine

5. Look at Diagram A for Question 5 in the separate Diagram Booklet. The diagram is NOT drawn to scale. Morgan is building 2 new houses on a plot of land.

Diagram A shows the plot of land.

Drainage pipes need to be laid from the 2 new houses to the connection point shown on the diagram.

Morgan cannot measure the lengths of the drainage pipes needed, as he does not have access to the connection point.

Look at Diagram B for Question 5 in the separate Diagram Booklet.

Morgan has drawn this diagram of the drainage pipes, showing some angles and lengths that he has been able to measure.

continued on the next page . . .

(Turn over)

**Length of the drainage pipe needed
from New House 1**

is _____ metres

**Length of the drainage pipe needed
from New House 2**

is _____ metres

[7 marks]

(Turn over)

- 6. Look at the diagram for Question 6 in the separate Diagram Booklet. The diagram is NOT drawn to scale. The diagram shows the front of Teifion's bungalow.**

Teifion is going to paint the front of his bungalow.

He will not be painting the roof, door or window.

The width of the bungalow is 610 cm.

The height of the bungalow is 300 cm.

The window is 220 cm wide and 140 cm high.

The door is 100 cm wide and 200 cm high.

continued on the next page . . .

(Turn over)

Question 6 continued

All the measurements on the diagram are CORRECT TO THE NEAREST 10 cm.

A litre of paint will cover 50 000 cm², CORRECT TO THE NEAREST 10 000 cm²

For a good finish, Teifion needs to paint the front of the bungalow 3 TIMES.

Calculate the SMALLEST POSSIBLE number of litres of paint that Teifion could use to paint the front of his bungalow 3 times.

(Turn over)

7. Isaac and his sister Mari are both going to open savings accounts.

(a) Isaac decides to invest some of his savings in the Hereford Saver account. Details of the account are shown below.

HEREFORD SAVER ACCOUNT
Monthly interest rate 0.26%

Calculate the AER that the Hereford Saver account offers. Give your answer as a percentage.

Question 7 continued

- 7. (b) Mari invests £3000 in the Silver Plus savings account. Details of the account are shown below.**

Account name	Nominal annual rate	Interest paid
Silver Plus	2.48%	Quarterly

Mari does not withdraw any money or make any further payments into the account.

Mari closes the account after 10 years.

continued on the next page . . .

(Turn over)

- 8. (a) Signs – R – Us is a company that makes national speed limit signs for roads.**

The national speed limit sign is white with a black strip across it.

Signs – R – Us needs to calculate the area of a sign that is white and the area that is black.

Look at the diagram for Question 8 (a) in the separate Diagram Booklet. The diagram is NOT drawn to scale.

The diagram shows some of the dimensions of the national speed limit sign.

continued on the next page . . .

(Turn over)

Question 8 (a) continued

The sign is a circle of radius 30 cm, centre O.

The centre of the black region is also at O.

The black region is NOT a rectangle.

Calculate the area of the sign that is white.

Hence, calculate the area of the sign that is black.

Area that is white = _____ cm²

Area that is black = _____ cm²

[6 marks]

continued on the next page . . .

(Turn over)

Question 8 continued

- 8. (b) Look at the diagram for Question 8 (b) in the separate Diagram Booklet. The diagram is NOT drawn to scale. The diagram represents a temporary road sign. Signs – R – Us makes temporary road signs for roadworks. These signs need to be moved easily. For each sign, Signs – R – Us makes a base with a vertical hole drilled through it, so that a pole can be placed inside.**

continued on the next page . . .

(Turn over)

Question 8 (b) continued

Signs – R – Us makes these bases for different – sized poles.

The radius of a hole is related to the mass of a base.

This is shown by the formula,

$$r = \sqrt[3]{\frac{M}{125(46 - 3\pi)}}$$

where:

**r is the radius in centimetres, and
 M is the mass in kilograms.**

**Rearrange this formula to make
 M the subject.**

(Turn over)

[2 marks]

continued on the next page . . .

(Turn over)

Question 8 continued

8. (c) Look at the table for Question 8 (c) in the separate Diagram Booklet. The table shows a number of different road signs.

As well as the national speed limit sign, Signs – R – Us makes 3 other road signs.

The table shows the number of road signs Signs – R – Us hopes to make every month.

Each month, Signs – R – Us plans to take a stratified sample of 60 signs to check the quality of their production.

continued on the next page . . .

(Turn over)

Question 8 continued

- 8. (d) Signs – R – Us also makes a speed bump. Ask for the model for Question 8 (d). The model is NOT made to scale. The model represents the speed bump.**

The speed bump has a uniform cross – sectional area, consisting of a quarter circle, a rectangle and a right – angled triangle.

Look at the diagram for Question 8 (d) in the separate Diagram Booklet. The diagram is NOT drawn to scale. The diagram shows the uniform cross – section.

continued on the next page . . .

(Turn over)

Question 8 (d) continued

The height of the speed bump is shown as h in the diagram.

The length of the rectangle is 4 times the height.

The total length of the speed bump is 8 times the height.

The width of the speed bump is 2 m, and its volume is 0.1 m^3

Calculate the height of the speed bump.

(Turn over)

[6 marks]

END OF PAPER
TOTAL 80 MARKS

(Turn over)



GCSE

3310U60-1

THURSDAY, 7 NOVEMBER 2024 – MORNING

**MATHEMATICS – NUMERACY
UNIT 2: CALCULATOR – ALLOWED
HIGHER TIER**

**The Diagram Booklet MUST
be handed in to the invigilators
and sent for marking.**

Diagram Booklet

Surname: _____

First name(s): _____

Centre Number: _____

Candidate Number: 0 _____

Question 1 (b)

Diagram NOT drawn to scale

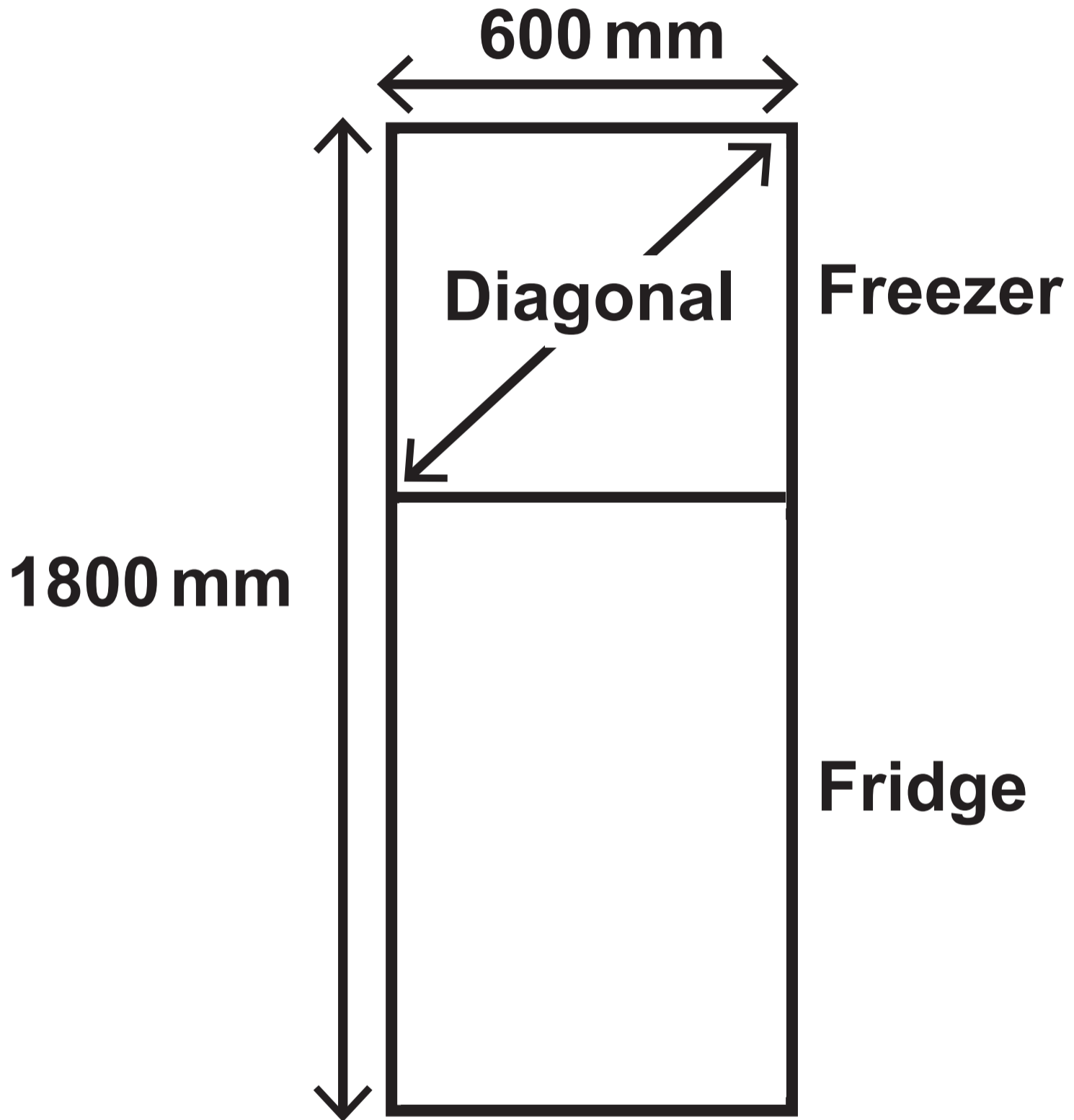

Question 2 (a) (ii)

The ratio of the masses is

fat : carbohydrate : protein : salt = 1360 : 2725 : 515 : 4

Question 3 (a)

Diagram NOT drawn to scale

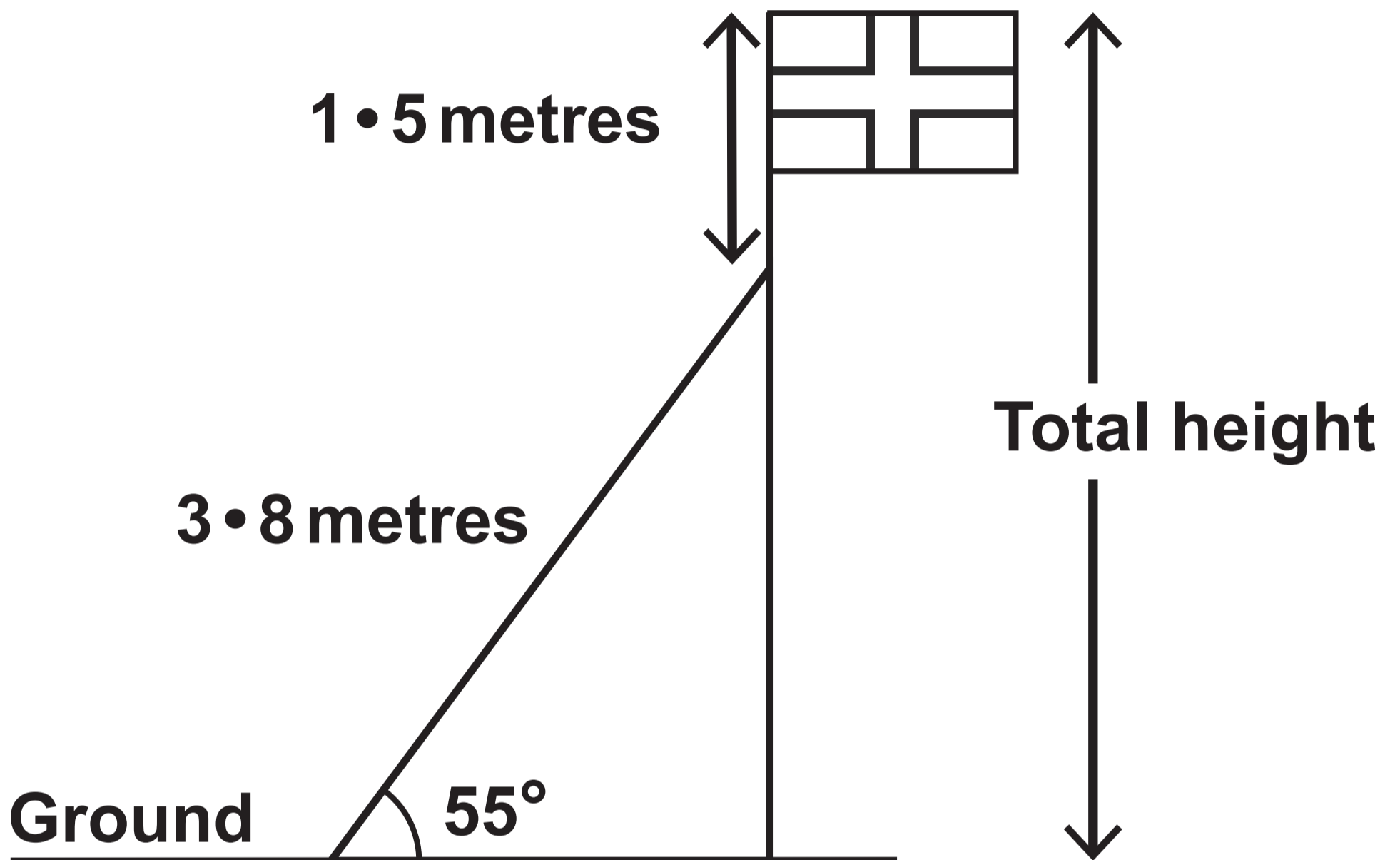

Question 3 (b)

Diagrams NOT drawn to scale

Large flag

120 cm

80 cm

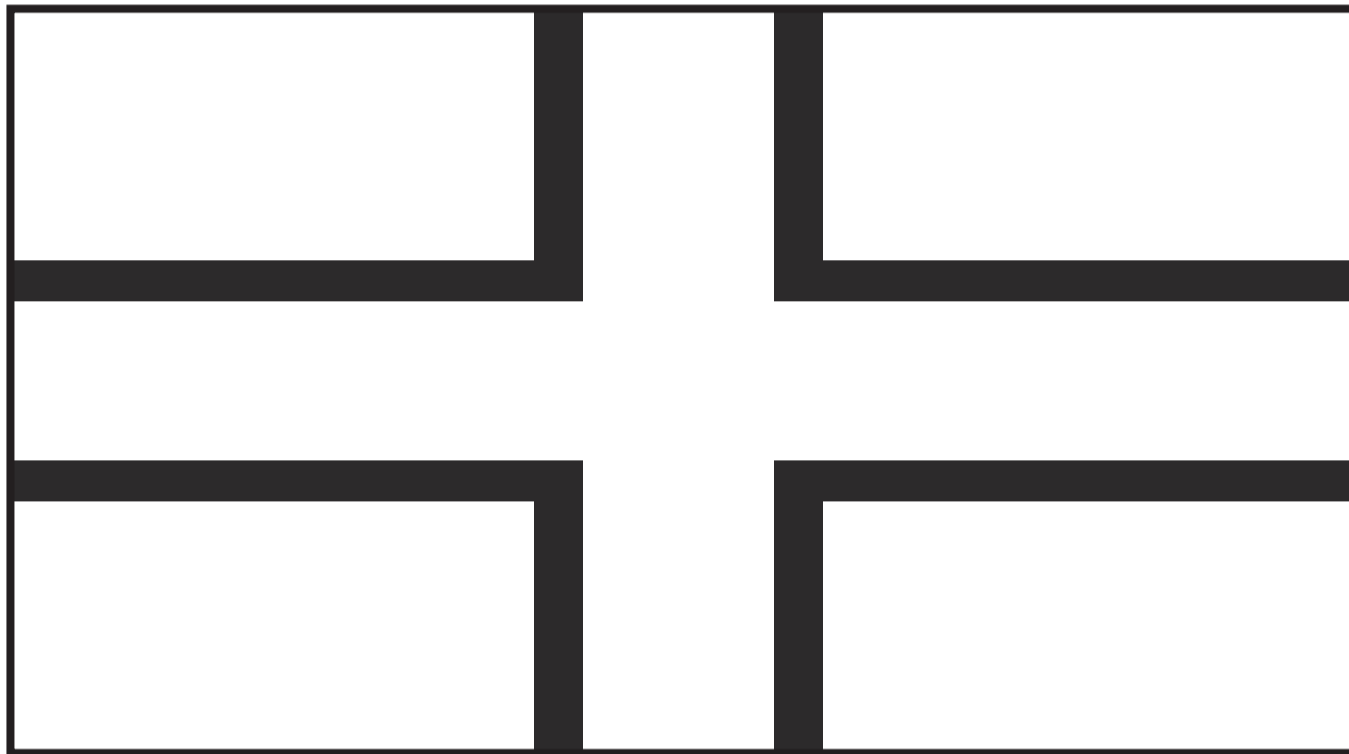

Medium flag

Length

64 cm

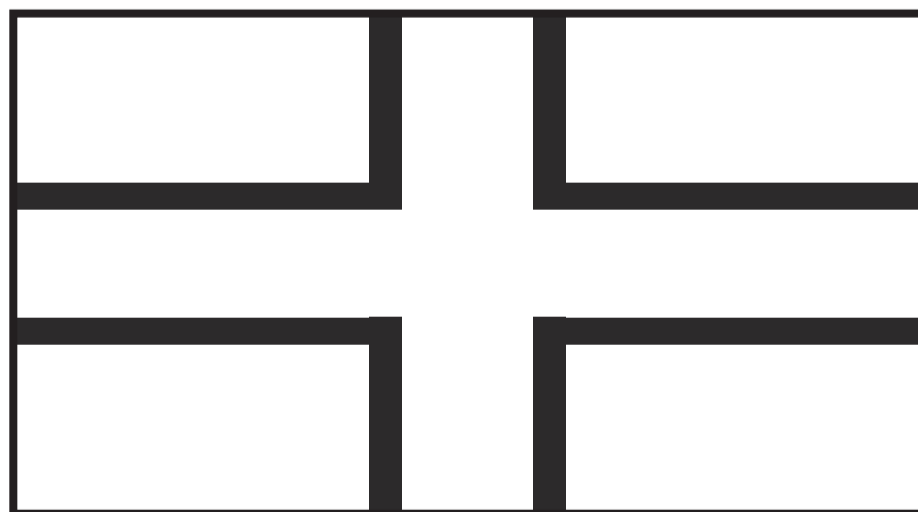

Small flag

75 cm

Height

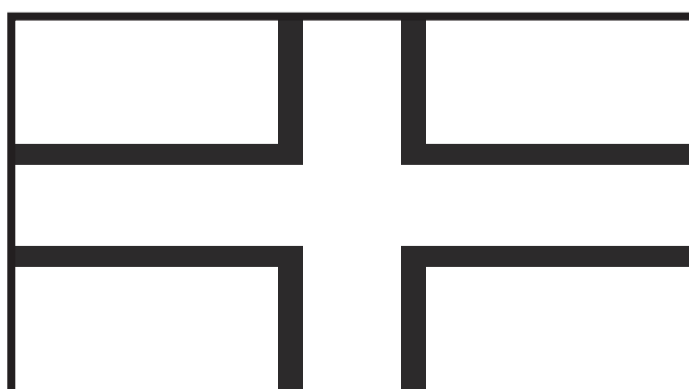

Question 4

NEW bird feeder

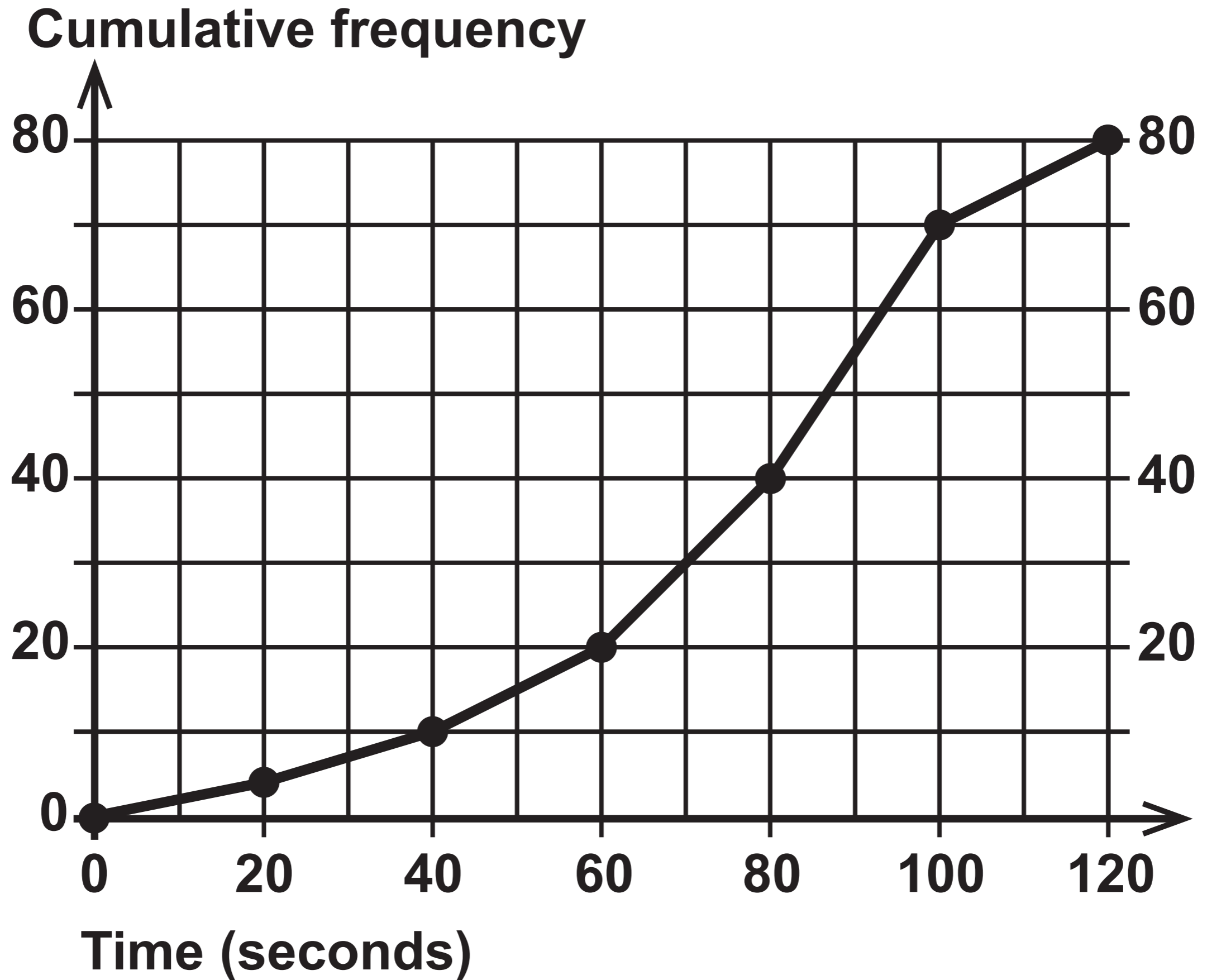

Question 4 (a)

ORIGINAL bird feeder	
Modal group	60 to 80 seconds
Median time	75 seconds
Interquartile range	20 seconds

Question 4 (c)

Variety of tree	Typical population density of grey squirrels PER km²
Oak	1200
Chestnut	100
Pine	45

Question 5

Diagram A

Diagram NOT drawn to scale

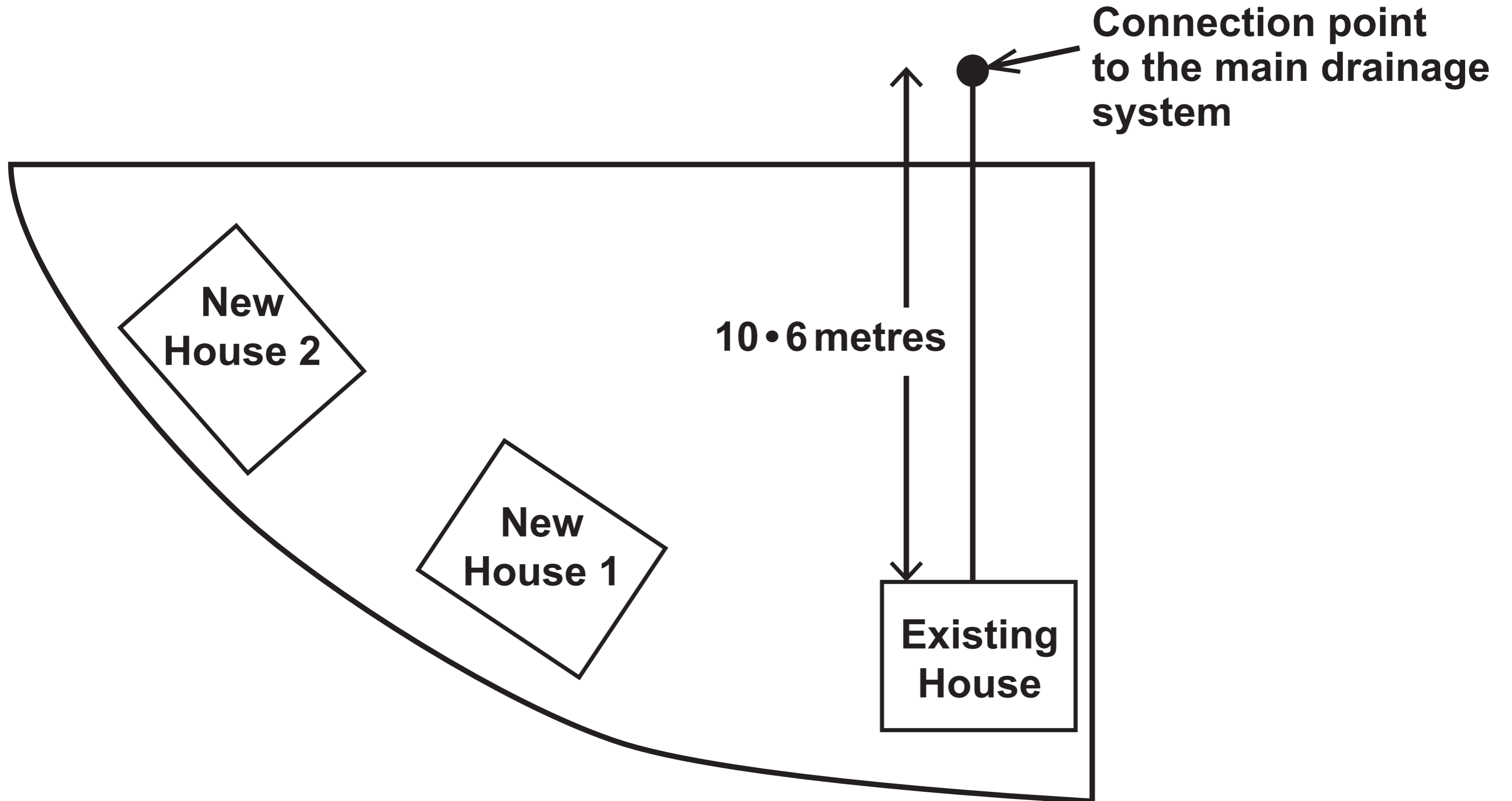

Question 5

Diagram B

Diagram NOT drawn to scale

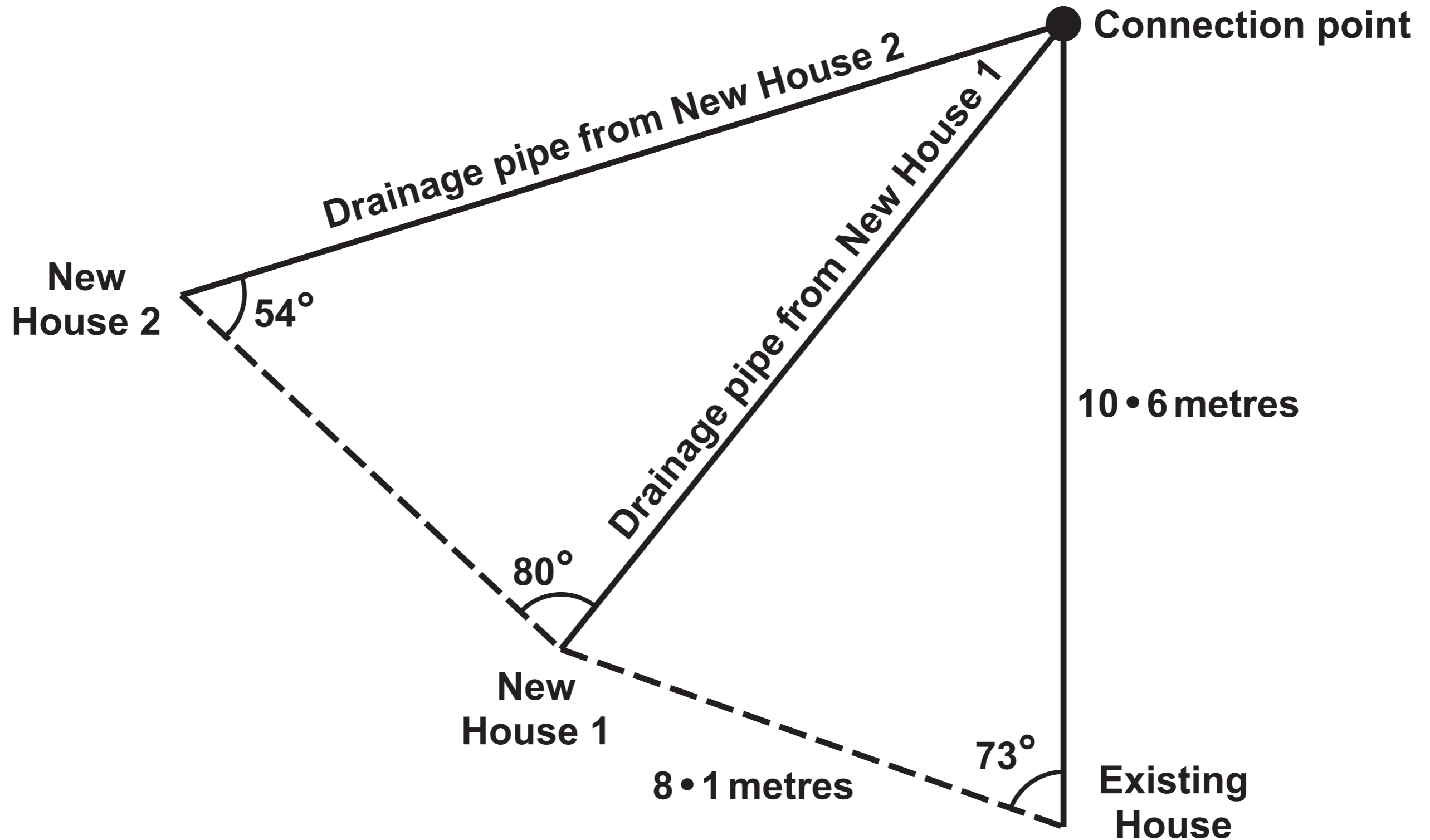

Question 6

Diagram NOT drawn to scale

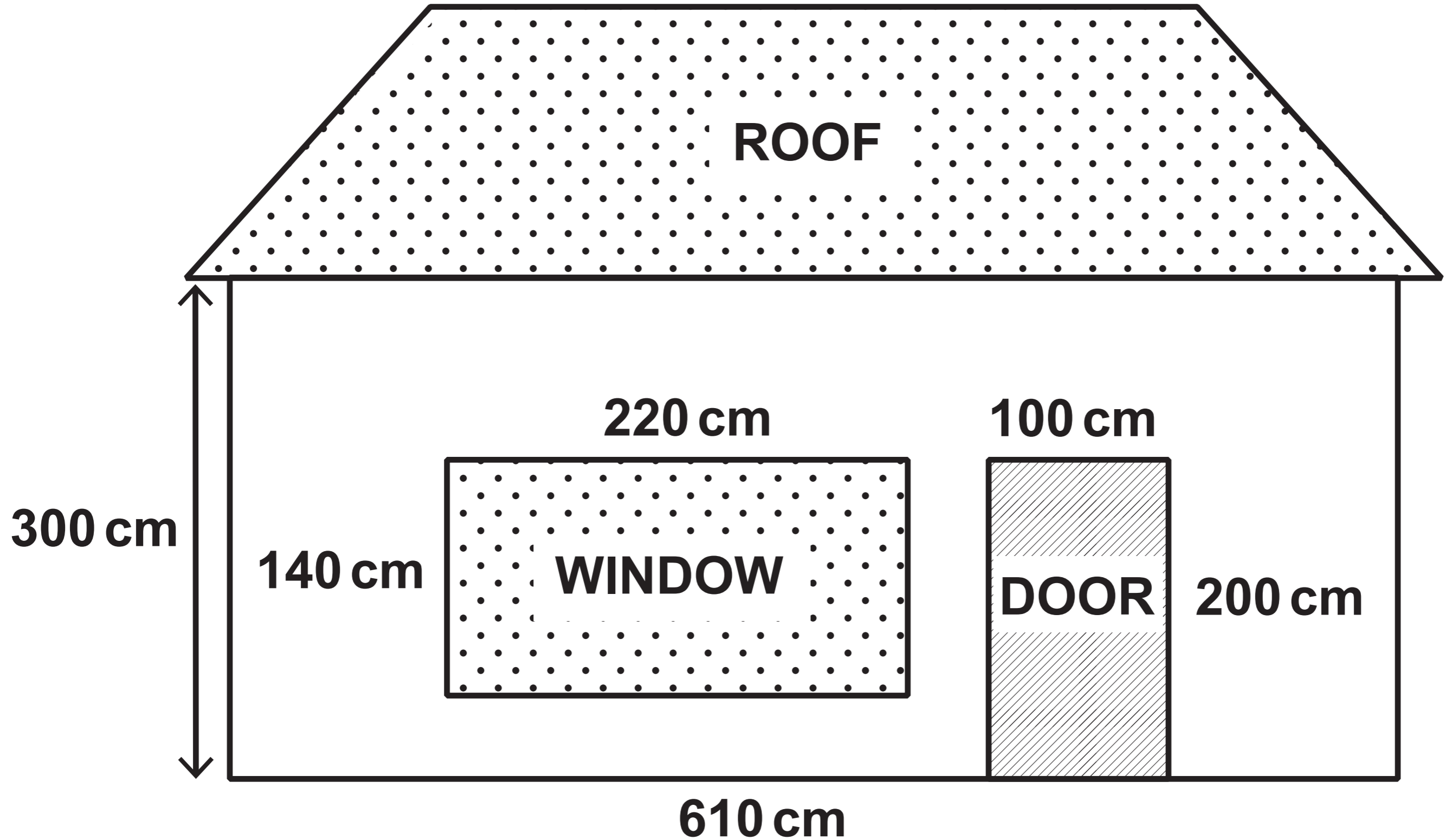

Question 8 (a)

Diagram NOT drawn to scale

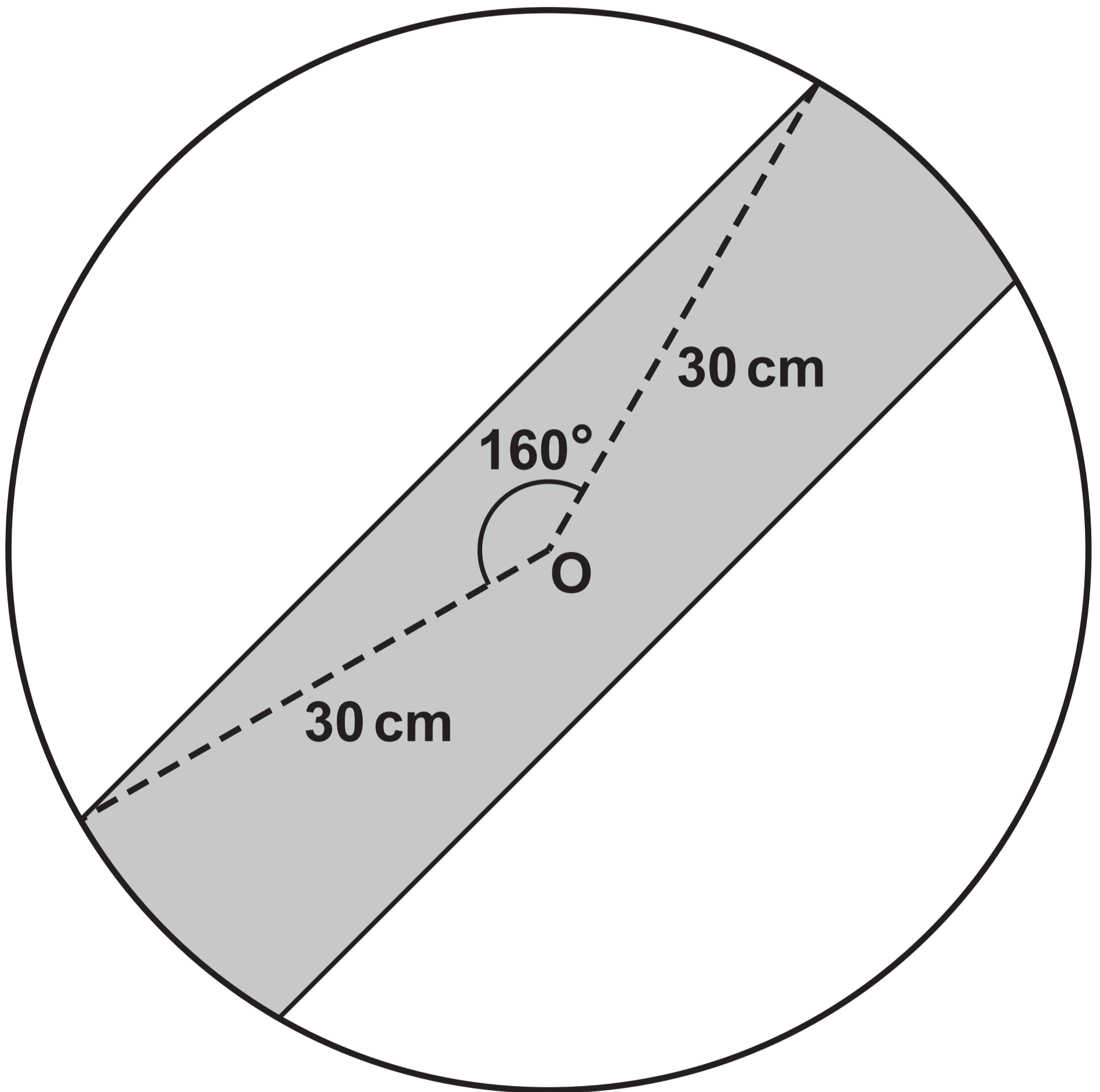



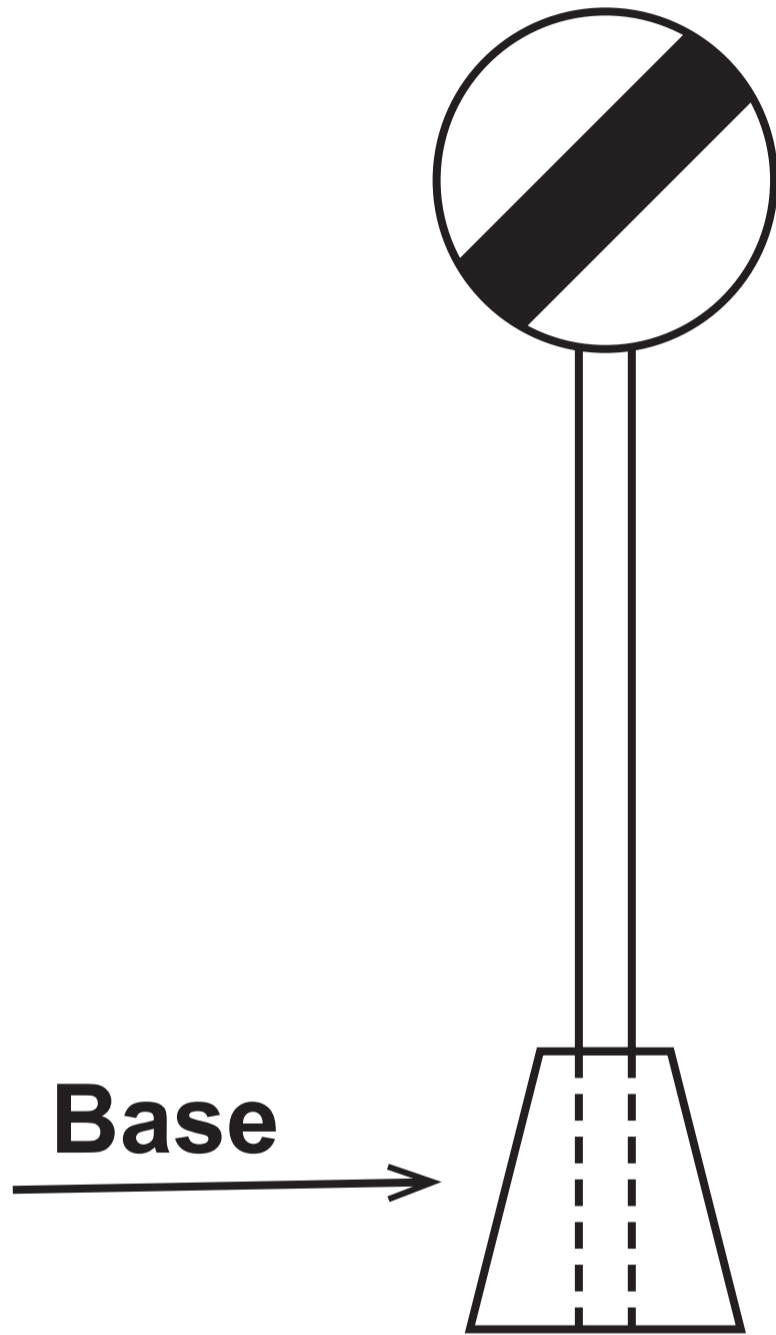

Question 8 (b)

Diagram NOT drawn to scale



Question 8 (c)

Type of sign	Number to be made each month
Stop 	148
Give way 	185
One way 	115
National speed limit 	87

Question 8 (d)

Diagram NOT drawn to scale

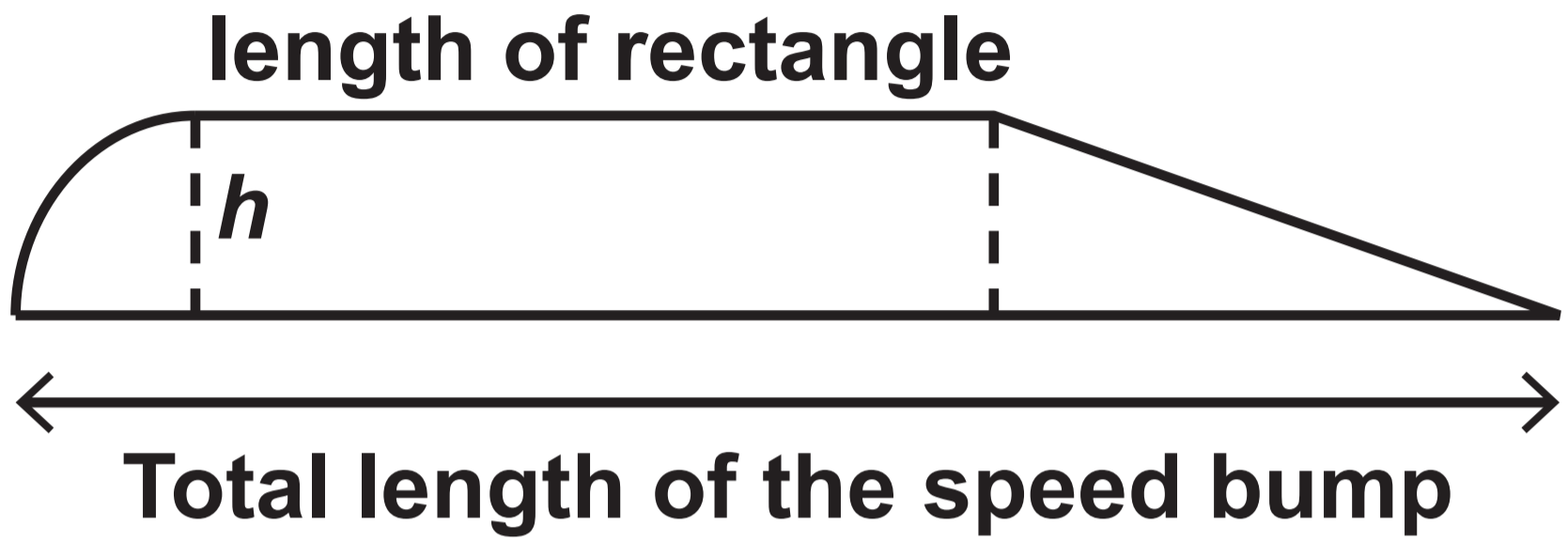

**GCSE
MATHEMATICS
and
GCSE
MATHEMATICS – NUMERACY**

**FORMULA LIST
INTERMEDIATE TIER
GCSE**

You must not write on these formula pages.

Anything you write on these formula pages will gain NO credit.

Formula List – Intermediate Tier

Area of trapezium $= \frac{1}{2} (a + b) h$

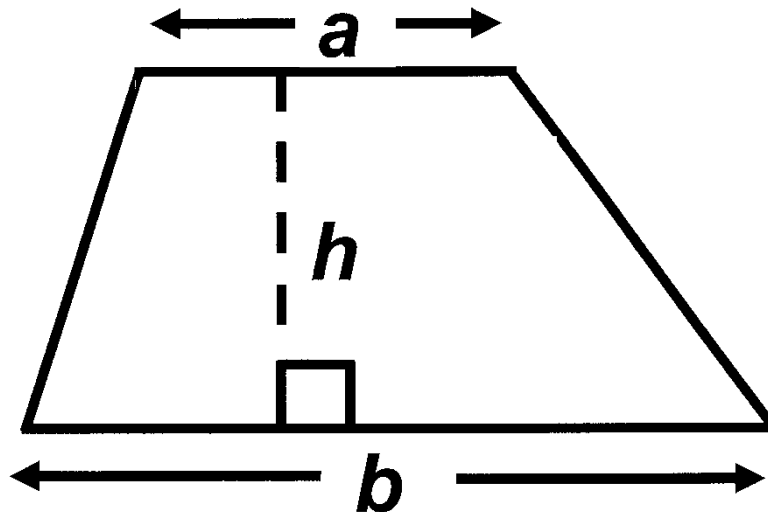

Volume of prism =
area of cross – section \times length

