

Surname	Centre Number	Candidate Number
First name(s)		0



GCSE

3445UA0-1



FRIDAY, 16 JUNE 2023 – MORNING

**APPLIED SCIENCE (Double Award)
UNIT 1: Energy, Resources and the Environment**

HIGHER TIER

1 hour 30 minutes

For Examiner's use only		
Question	Maximum Mark	Mark Awarded
1.	8	
2.	11	
3.	16	
4.	6	
5.	8	
6.	13	
7.	13	
Total	75	

ADDITIONAL MATERIALS

In addition to this paper you will require a calculator and a ruler.

INSTRUCTIONS TO CANDIDATES

Use black ink or black ball-point pen. Do not use gel pen or correction fluid.

You may use a pencil for graphs and diagrams only.

Write your name, centre number and candidate number in the spaces at the top of this page.

Answer **all** questions.

Write your answers in the spaces provided in this booklet. If you run out of space, use the additional page(s) at the back of the booklet, taking care to number the question(s) correctly.

INFORMATION FOR CANDIDATES

The number of marks is given in brackets at the end of each question or part-question.

Question 4 is a quality of extended response (QER) question where your writing skills will be assessed.

You are reminded to show all your workings. Credit is given for correct workings even when the final answer given is incorrect.

A Periodic Table is printed on page 20.



JUN233445UA0101

Answer **all** questions.

1. Sioned reacted sulfuric acid with zinc oxide (ZnO).
She followed the method below to form zinc sulfate.

1. Pour 50 cm³ of 1.0 mol/dm³ sulfuric acid into a conical flask.
2. Heat the sulfuric acid to 50°C.
3. Add 5 g of zinc oxide to the warmed acid and stir.
4. Repeat step 3 until the zinc oxide is in excess.

- (a) The main hazard in this experiment is that 1.0 mol/dm³ sulfuric acid is an irritant.

(i) Describe **one** risk associated with using sulfuric acid. [1]

.....
.....

(ii) State a suitable control measure Sioned should carry out to reduce this risk. [1]

.....
.....

- (b) **Circle** the correct formula in each bracket to complete the symbol equation for this reaction. [2]



- (c) State **two** additional steps that Sioned needs to carry out to obtain pure zinc sulfate crystals. [2]

1.

.....

2.

.....



- (d) Robert has calculated the relative formula mass of zinc oxide to be 97.
Use the Periodic Table on page 20 to explain if he is correct.

[2]

8

3445UA01
03

2. Several groups of students investigated the rate of diffusion of blue dye into potato by the method below.

1. Cut a cylinder of potato.
2. Place the cylinder in a test tube containing a solution of blue dye.
3. Put the test tube in a water bath at 20°C.
4. Measure the concentration of the dye after 20 minutes.
5. Continue to measure the concentration every 20 minutes up to 80 minutes.

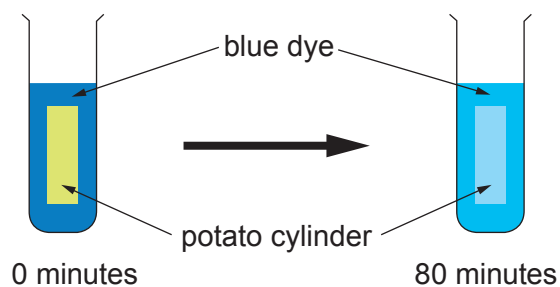

The concentration of the dye left in the test tube after each 20-minute interval is shown on the graph below.

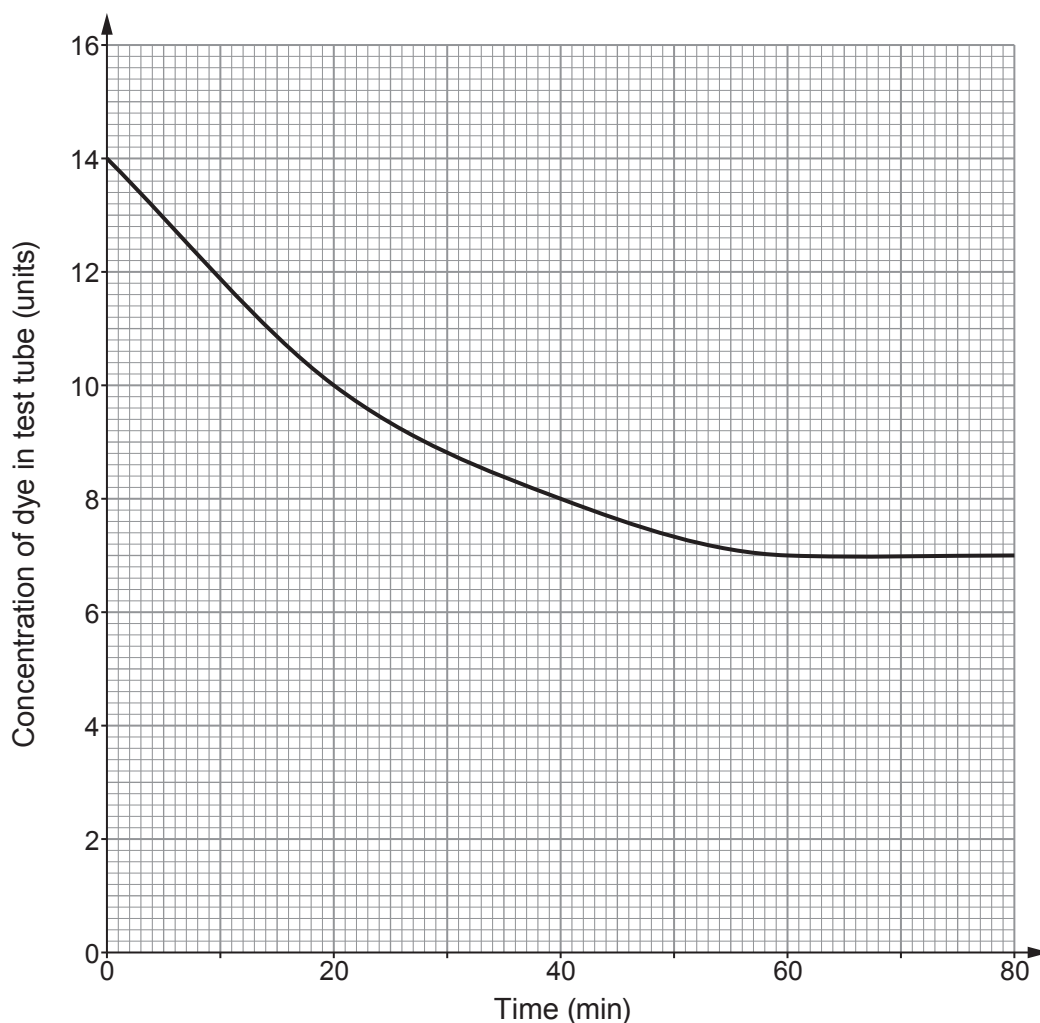

(a) (i) State the dependent variable in this experiment. [1]

.....

(ii) State **two** variables that should be controlled. [2]

1.

2.

(b) (i) State how the concentration of dye left in the test tube changed during the first 20 minutes. [1]

(ii) Explain why this change occurred. [2]

.....
.....
.....
.....
.....

(c) One student suggests that the rate of diffusion is constant over the whole 80 minutes. Explain whether you agree. [3]

.....
.....
.....
.....
.....
.....

(d) The students repeated the experiment in a water bath at 30°C. **Add another line** to the graph to show the expected results. [2]

11

3445UA01
05



3. One renewable energy source that large energy suppliers use to generate electricity is wind. The percentage of electricity generated in this way has been gradually increasing over the last few years.

The graph below shows the power output of a wind turbine in one day. This wind turbine has a mean output of 0.6 MW.

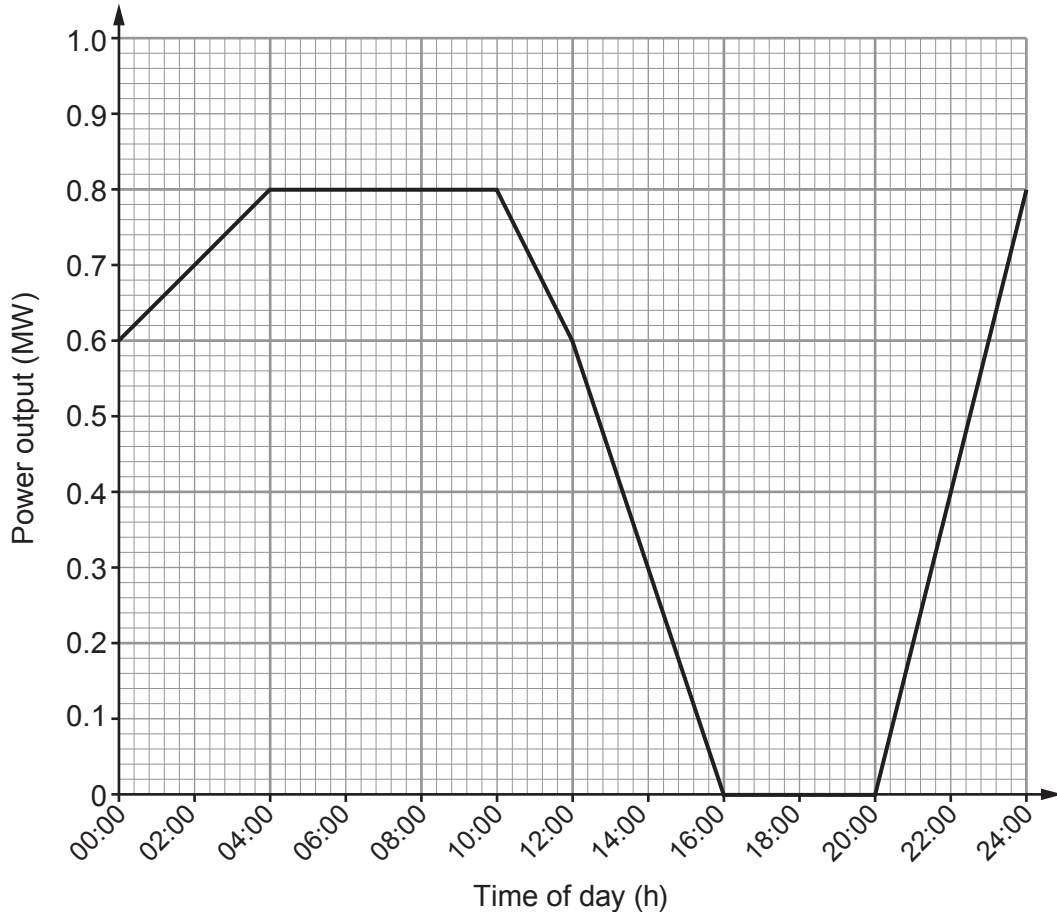

- (a) Use the graph and the equation:

$$\text{units generated (kWh)} = \text{power (kW)} \times \text{time (h)}$$

to calculate the number of units generated between 04:00 and 10:00. [4]

(1 MW = 1000 kW)

number of units = kWh



- (b) The table below gives information about generating electricity by wind and a nuclear power station.

	wind turbine	nuclear power station
expected lifetime (years)	20	60
mean power output (MW)	0.60	3 600
land area needed (km ²)	0.55	4.5
cost to commission (£ million)	3	4 000
waste produced	none	radioactive waste
lifetime carbon footprint (gCO ₂ /kWh)	5	5
overall cost of generating electricity (p/kWh)	5.6	2.8

Use the table to answer the following questions.

- (i) Calculate the number of wind turbines that need to be built to provide the same power as the nuclear power station will provide in its lifetime. [2]

number of wind turbines =

- (ii) Calculate the land area needed by a wind farm to produce the same power as one nuclear power station. [3]

land area = km²



(c) (i) Evaluate the cost effectiveness of the two methods of generating electricity. [3]

.....

.....

.....

.....

.....

.....

(ii) Evaluate the environmental impact of the two methods of generating electricity. [2]

.....

.....

.....

.....

(d) The lifetime carbon footprints of a wind farm and a nuclear power station are 5gCO₂/kWh.

Suggest how the carbon footprint of a coal-fired power station might compare to this value.

Give a reason for your answer. [2]

.....

.....

.....

16



Examiner
only

6



5. Developments in plastic technology have allowed the production of bioplastics using plants as the source of raw material.

The table below compares the production of the same mass of a bioplastic with polystyrene. Polystyrene is made from crude oil.

	Bioplastic	Polystyrene
Energy consumption (kWh)	10.7	22.6
Water used in production (dm ³)	74.6	185
Waste for landfill produced (g)	1.74	2.10
Biodegradable	Yes	No
Breakdown products	carbon dioxide, water and methane	styrene
kgCO ₂ eq/kg produced	0.50	2.2

Use your knowledge and the information in the table to answer the following questions.

- (a) Explain **two** advantages to the environment of using bioplastics. [4]

.....

.....

.....

.....

.....

- (b) Explain **one** environmental disadvantage of using bioplastics. [2]

.....

.....

.....

- (c) Manufacturers of this bioplastic claim that it is a carbon-neutral product. State the additional information that is needed to support this claim. [2]

.....

.....

.....



6. Jamie is investigating series and parallel electrical circuits.

The following equations apply to electrical circuits:

$$\text{current} = \frac{\text{voltage}}{\text{resistance}}$$

$$\text{power} = \text{voltage} \times \text{current}$$

$$\text{power} = \text{current}^2 \times \text{resistance}$$

$$R_T = R_1 + R_2 \dots\dots\dots$$

$$\frac{1}{R_T} = \frac{1}{R_1} + \frac{1}{R_2} \dots\dots\dots$$

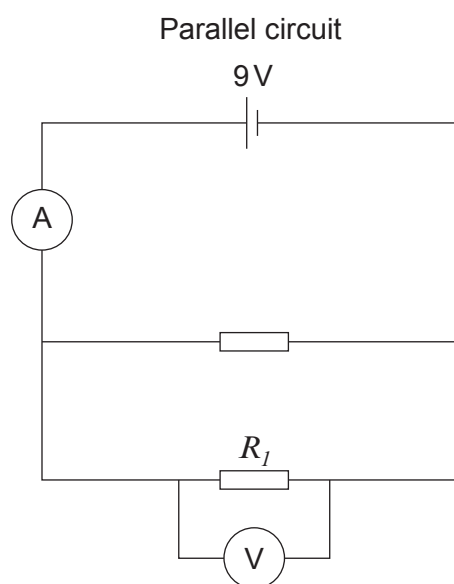
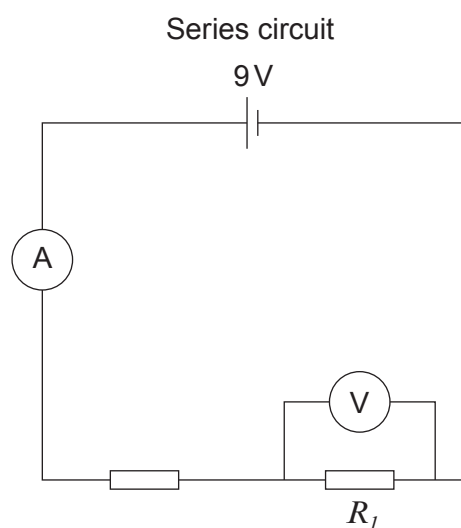

(a) Jamie built the circuits above with identical resistors. In the series circuit the total resistance is 4.5 ohms and the ammeter reading is 2 Amps.

(i) I. Compare the total resistance in the parallel circuit with the series circuit. [2]

.....

.....



II. Compare the ammeter reading in the parallel circuit with the series circuit. [1]

.....

(ii) Explain how the voltmeter readings in the two circuits compare. [2]

.....

.....

.....

(iii) Explain how the power dissipated in resistor R_1 in each circuit compares. [2]

.....

.....

.....

(b) Jamie used identical 2.25Ω resistors in both circuits.

(i) Calculate the power dissipated by R_1 in the parallel circuit. [4]

power dissipated = W

(ii) Use your answer above to calculate the power dissipated in resistor R_1 in the series circuit. [2]

power dissipated = W

13



7. The diagram below shows the extraction of aluminium from aluminium oxide by electrolysis.

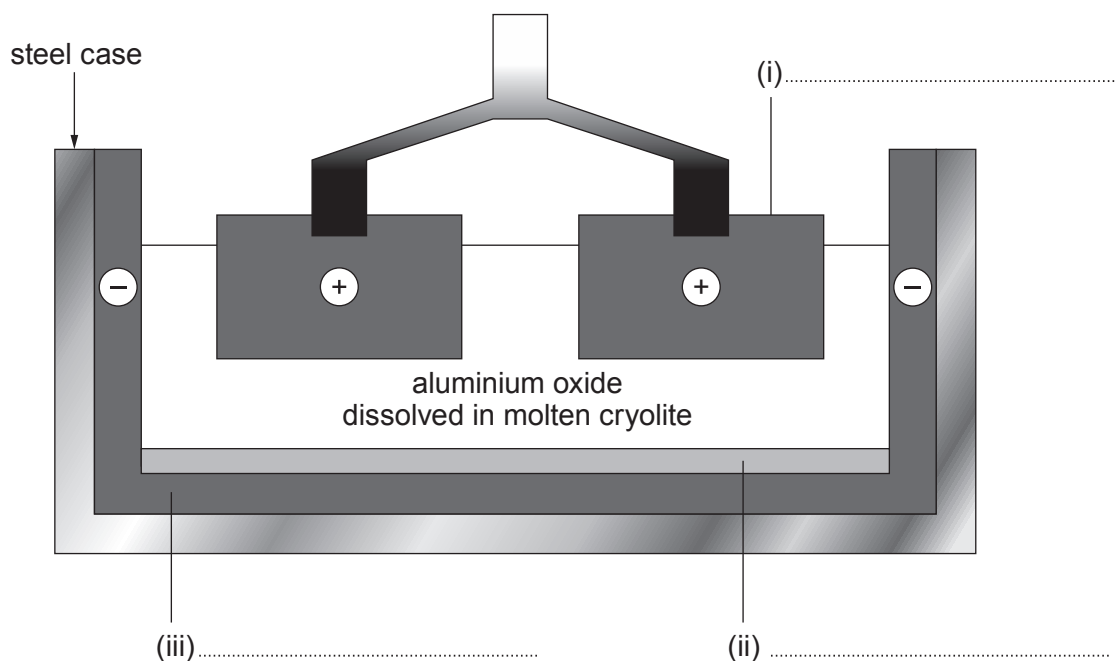

- (a) Complete the labelling of the diagram above. [3]
- (b) Complete the balanced **symbol** equation for this process. [3]

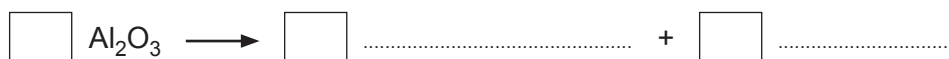

- (c) Explain, in terms of electrons, what happens at each of the electrodes. [3]

.....

.....

.....

.....

.....



(d) Over the last 10 years the mass of aluminium recycled in Wales has increased.

(i) Suggest **two** economic benefits of recycling aluminium. [2]

.....

.....

.....

.....

(ii) Explain **one** environmental benefit of recycling aluminium. [2]

.....

.....

.....

13

END OF PAPER



BLANK PAGE

**PLEASE DO NOT WRITE
ON THIS PAGE**



BLANK PAGE

**PLEASE DO NOT WRITE
ON THIS PAGE**





THE PERIODIC TABLE

Group 1 2 3 4 5 6 7 0

7 Li Lithium 3	9 Be Beryllium 4	11 Na Sodium 11	12 Mg Magnesium 12	13 Al Aluminium 13	14 Si Silicon 14	15 P Phosphorus 15	16 S Sulfur 16	17 Cl Chlorine 17	18 Ar Argon 18	19 F Fluorine 9	20 Ne Neon 10
23 Na Sodium 11	24 Mg Magnesium 12	27 Al Aluminium 13	28 Si Silicon 14	29 Cu Copper 29	30 Zn Zinc 30	31 Ga Gallium 31	32 Ge Germanium 32	33 As Arsenic 33	34 Se Selenium 34	35 Br Bromine 35	36 Kr Krypton 36
39 K Potassium 19	40 Ca Calcium 20	45 Sc Scandium 21	46 Ti Titanium 22	47 V Vanadium 23	48 Cr Chromium 24	49 Mn Manganese 25	50 Fe Iron 26	51 Co Cobalt 27	52 Ni Nickel 28	53 Cu Copper 29	54 Zn Zinc 30
86 Rb Rubidium 37	87 Sr Strontium 38	89 Y Yttrium 39	90 Zr Zirconium 40	91 Nb Niobium 41	92 Mo Molybdenum 42	93 Tc Technetium 43	94 Ru Ruthenium 44	95 Rh Rhodium 45	96 Pd Palladium 46	97 Ag Silver 47	98 Cd Cadmium 48
133 Cs Caesium 55	137 Ba Barium 56	139 La Lanthanum 57	140 Hf Hafnium 72	141 Ta Tantalum 73	142 W Tungsten 74	143 Re Rhenium 75	144 Os Osmium 76	145 Ir Iridium 77	146 Pt Platinum 78	147 Au Gold 79	148 Hg Mercury 80
223 Fr Francium 87	226 Ra Radium 88	227 Ac Actinium 89	228 Th Thorium 90	229 Pa Protactinium 91	230 U Uranium 92	231 Np Neptunium 93	232 Pu Plutonium 94	233 Am Americium 95	234 Cm Curium 96	235 Bk Berkelium 97	236 Cf Californium 98
101 B Boron 5	102 C Carbon 6	103 N Nitrogen 7	104 O Oxygen 8	105 F Fluorine 9	106 Ne Neon 10	107 He Helium 2	108 Li Lithium 3	109 Be Beryllium 4	110 B Boron 5	111 C Carbon 6	112 N Nitrogen 7
115 In Indium 49	116 Tl Thallium 81	117 Cs Caesium 55	118 Ba Barium 56	119 La Lanthanum 57	120 Hf Hafnium 72	121 Ta Tantalum 73	122 W Tungsten 74	123 Re Rhenium 75	124 Os Osmium 76	125 Ir Iridium 77	126 Pt Platinum 78
119 Sn Tin 50	120 Pb Lead 82	121 Bi Bismuth 83	122 Po Polonium 84	123 At Astatine 85	124 Rn Radon 86	125 He Helium 2	126 Li Lithium 3	127 Be Beryllium 4	128 B Boron 5	129 C Carbon 6	130 N Nitrogen 7
122 Sb Antimony 51	123 Te Tellurium 52	124 I Iodine 53	125 Xe Xenon 54	126 Fr Francium 87	127 Ra Radium 88	128 Ac Actinium 89	129 Th Thorium 90	130 Pa Protactinium 91	131 U Uranium 92	132 Np Neptunium 93	133 Pu Plutonium 94
127 Te Tellurium 52	128 I Iodine 53	129 Xe Xenon 54	130 Fr Francium 87	131 Ra Radium 88	132 Ac Actinium 89	133 Th Thorium 90	134 Pa Protactinium 91	135 U Uranium 92	136 Np Neptunium 93	137 Pu Plutonium 94	138 Am Americium 95
131 Xe Xenon 54	132 Fr Francium 87	133 Ra Radium 88	134 Ac Actinium 89	135 Th Thorium 90	136 Pa Protactinium 91	137 U Uranium 92	138 Np Neptunium 93	139 Pu Plutonium 94	140 Am Americium 95	141 Cm Curium 96	142 Bk Berkelium 97
135 Br Bromine 35	136 Kr Krypton 36	137 Rb Rubidium 37	138 Sr Strontium 38	139 Y Yttrium 39	140 Zr Zirconium 40	141 Nb Niobium 41	142 Mo Molybdenum 42	143 Tc Technetium 43	144 Ru Ruthenium 44	145 Rh Rhodium 45	146 Pd Palladium 46
139 Ag Silver 47	140 Cd Cadmium 48	141 In Indium 49	142 Tl Thallium 81	143 Cs Caesium 55	144 Ba Barium 56	145 La Lanthanum 57	146 Hf Hafnium 72	147 Ta Tantalum 73	148 W Tungsten 74	149 Re Rhenium 75	150 Os Osmium 76
143 Cs Caesium 55	144 Ba Barium 56	145 La Lanthanum 57	146 Hf Hafnium 72	147 Ta Tantalum 73	148 W Tungsten 74	149 Re Rhenium 75	150 Os Osmium 76	151 Ir Iridium 77	152 Pt Platinum 78	153 Au Gold 79	154 Hg Mercury 80
147 Ag Silver 47	148 Cd Cadmium 48	149 In Indium 49	150 Tl Thallium 81	151 Cs Caesium 55	152 Ba Barium 56	153 La Lanthanum 57	154 Hf Hafnium 72	155 Ta Tantalum 73	156 W Tungsten 74	157 Re Rhenium 75	158 Os Osmium 76
151 Sb Antimony 51	152 Te Tellurium 52	153 I Iodine 53	154 Xe Xenon 54	155 Fr Francium 87	156 Ra Radium 88	157 Ac Actinium 89	158 Th Thorium 90	159 Pa Protactinium 91	160 U Uranium 92	161 Np Neptunium 93	162 Pu Plutonium 94
155 Br Bromine 35	156 Kr Krypton 36	157 Rb Rubidium 37	158 Sr Strontium 38	159 Y Yttrium 39	160 Zr Zirconium 40	161 Nb Niobium 41	162 Mo Molybdenum 42	163 Tc Technetium 43	164 Ru Ruthenium 44	165 Rh Rhodium 45	166 Pd Palladium 46
159 Ag Silver 47	160 Cd Cadmium 48	161 In Indium 49	162 Tl Thallium 81	163 Cs Caesium 55	164 Ba Barium 56	165 La Lanthanum 57	166 Hf Hafnium 72	167 Ta Tantalum 73	168 W Tungsten 74	169 Re Rhenium 75	170 Os Osmium 76
163 Cs Caesium 55	164 Ba Barium 56	165 La Lanthanum 57	166 Hf Hafnium 72	167 Ta Tantalum 73	168 W Tungsten 74	169 Re Rhenium 75	170 Os Osmium 76	171 Ir Iridium 77	172 Pt Platinum 78	173 Au Gold 79	174 Hg Mercury 80
167 Ag Silver 47	168 Cd Cadmium 48	169 In Indium 49	170 Tl Thallium 81	171 Cs Caesium 55	172 Ba Barium 56	173 La Lanthanum 57	174 Hf Hafnium 72	175 Ta Tantalum 73	176 W Tungsten 74	177 Re Rhenium 75	178 Os Osmium 76
171 Sb Antimony 51	172 Te Tellurium 52	173 I Iodine 53	174 Xe Xenon 54	175 Fr Francium 87	176 Ra Radium 88	177 Ac Actinium 89	178 Th Thorium 90	179 Pa Protactinium 91	180 U Uranium 92	181 Np Neptunium 93	182 Pu Plutonium 94
175 Br Bromine 35	176 Kr Krypton 36	177 Rb Rubidium 37	178 Sr Strontium 38	179 Y Yttrium 39	180 Zr Zirconium 40	181 Nb Niobium 41	182 Mo Molybdenum 42	183 Tc Technetium 43	184 Ru Ruthenium 44	185 Rh Rhodium 45	186 Pd Palladium 46
179 Ag Silver 47	180 Cd Cadmium 48	181 In Indium 49	182 Tl Thallium 81	183 Cs Caesium 55	184 Ba Barium 56	185 La Lanthanum 57	186 Hf Hafnium 72	187 Ta Tantalum 73	188 W Tungsten 74	189 Re Rhenium 75	190 Os Osmium 76
183 Cs Caesium 55	184 Ba Barium 56	185 La Lanthanum 57	186 Hf Hafnium 72	187 Ta Tantalum 73	188 W Tungsten 74	189 Re Rhenium 75	190 Os Osmium 76	191 Ir Iridium 77	192 Pt Platinum 78	193 Au Gold 79	194 Hg Mercury 80
187 Ag Silver 47	188 Cd Cadmium 48	189 In Indium 49	190 Tl Thallium 81	191 Cs Caesium 55	192 Ba Barium 56	193 La Lanthanum 57	194 Hf Hafnium 72	195 Ta Tantalum 73	196 W Tungsten 74	197 Re Rhenium 75	198 Os Osmium 76
191 Sb Antimony 51	192 Te Tellurium 52	193 I Iodine 53	194 Xe Xenon 54	195 Fr Francium 87	196 Ra Radium 88	197 Ac Actinium 89	198 Th Thorium 90	199 Pa Protactinium 91	200 U Uranium 92	201 Np Neptunium 93	202 Pu Plutonium 94
195 Br Bromine 35	196 Kr Krypton 36	197 Rb Rubidium 37	198 Sr Strontium 38	199 Y Yttrium 39	200 Zr Zirconium 40	201 Nb Niobium 41	202 Mo Molybdenum 42	203 Tc Technetium 43	204 Ru Ruthenium 44	205 Rh Rhodium 45	206 Pd Palladium 46
199 Ag Silver 47	200 Cd Cadmium 48	201 In Indium 49	202 Tl Thallium 81	203 Cs Caesium 55	204 Ba Barium 56	205 La Lanthanum 57	206 Hf Hafnium 72	207 Ta Tantalum 73	208 W Tungsten 74	209 Re Rhenium 75	210 Os Osmium 76
203 Cs Caesium 55	204 Ba Barium 56	205 La Lanthanum 57	206 Hf Hafnium 72	207 Ta Tantalum 73	208 W Tungsten 74	209 Re Rhenium 75	210 Os Osmium 76	211 Ir Iridium 77	212 Pt Platinum 78	213 Au Gold 79	214 Hg Mercury 80
207 Ag Silver 47	208 Cd Cadmium 48	209 In Indium 49	210 Tl Thallium 81	211 Cs Caesium 55	212 Ba Barium 56	213 La Lanthanum 57	214 Hf Hafnium 72	215 Ta Tantalum 73	216 W Tungsten 74	217 Re Rhenium 75	218 Os Osmium 76
211 Sb Antimony 51	212 Te Tellurium 52	213 I Iodine 53	214 Xe Xenon 54	215 Fr Francium 87	216 Ra Radium 88	217 Ac Actinium 89	218 Th Thorium 90	219 Pa Protactinium 91	220 U Uranium 92	221 Np Neptunium 93	222 Pu Plutonium 94
215 Br Bromine 35	216 Kr Krypton 36	217 Rb Rubidium 37	218 Sr Strontium 38	219 Y Yttrium 39	220 Zr Zirconium 40	221 Nb Niobium 41	222 Mo Molybdenum 42	223 Tc Technetium 43	224 Ru Ruthenium 44	225 Rh Rhodium 45	226 Pd Palladium 46
219 Ag Silver 47	220 Cd Cadmium 48	221 In Indium 49	222 Tl Thallium 81	223 Cs Caesium 55	224 Ba Barium 56	225 La Lanthanum 57	226 Hf Hafnium 72	227 Ta Tantalum 73	228 W Tungsten 74	229 Re Rhenium 75	230 Os Osmium 76
223 Cs Caesium 55	224 Ba Barium 56	225 La Lanthanum 57	226 Hf Hafnium 72	227 Ta Tantalum 73	228 W Tungsten 74	229 Re Rhenium 75	230 Os Osmium 76	231 Ir Iridium 77	232 Pt Platinum 78	233 Au Gold 79	234 Hg Mercury 80
227 Ag Silver 47	228 Cd Cadmium 48	229 In Indium 49	230 Tl Thallium 81	231 Cs Caesium 55	232 Ba Barium 56	233 La Lanthanum 57	234 Hf Hafnium 72	235 Ta Tantalum 73	236 W Tungsten 74	237 Re Rhenium 75	238 Os Osmium 76
231 Sb Antimony 51	232 Te Tellurium 52	233 I Iodine 53	234 Xe Xenon 54	235 Fr Francium 87	236 Ra Radium 88	237 Ac Actinium 89	238 Th Thorium 90	239 Pa Protactinium 91	240 U Uranium 92	241 Np Neptunium 93	242 Pu Plutonium 94
235 Br Bromine 35	236 Kr Krypton 36	237 Rb Rubidium 37	238 Sr Strontium 38	239 Y Yttrium 39	240 Zr Zirconium 40	241 Nb Niobium 41	242 Mo Molybdenum 42	243 Tc Technetium 43	244 Ru Ruthenium 44	245 Rh Rhodium 45	246 Pd Palladium 46
239 Ag Silver 47	240 Cd Cadmium 48	241 In Indium 49	242 Tl Thallium 81	243 Cs Caesium 55	244 Ba Barium 56	245 La Lanthanum 57	246 Hf Hafnium 72	247 Ta Tantalum 73	248 W Tungsten 74	249 Re Rhenium 75	