



**GCE A LEVEL**

**1300U40-1**

**TUESDAY, 11 JUNE 2024 – AFTERNOON**

**MATHEMATICS – A2 unit 4**

**APPLIED MATHEMATICS B**

**1 hour 45 minutes plus your additional  
time allowance**

**Surname** \_\_\_\_\_

**First name(s)** \_\_\_\_\_

**Centre Number** \_\_\_\_\_

**Candidate Number** 2 \_\_\_\_\_

**For Examiner's use only**

<b>Question</b>	<b>Maximum Mark</b>	<b>Mark Awarded</b>
<b>1</b>	<b>3</b>	
<b>2</b>	<b>8</b>	
<b>3</b>	<b>8</b>	
<b>4</b>	<b>21</b>	
<b>5</b>	<b>7</b>	
<b>6</b>	<b>8</b>	
<b>7</b>	<b>7</b>	
<b>8</b>	<b>7</b>	
<b>9</b>	<b>11</b>	
<b>Total</b>	<b>80</b>	

**ADDITIONAL MATERIALS**

**In addition to this examination paper, you will need:**

- **a Formula Booklet;**
- **a calculator;**
- **statistical tables (RND/WJEC Publications).**

**(Turn over)**

## **INSTRUCTIONS TO CANDIDATES**

**Use black ink, black ball-point pen or your usual method.**

**You may use a pencil for graphs and diagrams only.**

**Write your name, centre number and candidate number in the spaces provided on the front cover.**

**Answer ALL questions.**

**Take  $g$  as  $9.8 \text{ ms}^{-2}$**

**Write your answers in the spaces provided in this booklet. If you run out of space, use the additional page(s) at the back of the booklet, taking care to number the question(s) correctly.**

**(Turn over)**

**INFORMATION FOR CANDIDATES**

**The maximum mark for this paper is 80.**

**The number of marks is given in brackets at the end of each question or part-question.**

**Sufficient working must be shown to demonstrate the MATHEMATICAL method employed.**

**Answers without working may not gain full credit.**

**Unless the degree of accuracy is stated in the question, answers should be rounded appropriately.**

**You are reminded of the necessity for good English and orderly presentation in your answers.**

**(Turn over)**

	<b>SCHOOL</b>	<b>COLLEGE</b>	<b>EMPLOYMENT</b>	<b>OTHER</b>	<b>TOTAL</b>
<b>BOYS</b>	<b>33</b>	<b>49</b>	<b>8</b>	<b>2</b>	<b>92</b>
<b>GIRLS</b>	<b>40</b>	<b>40</b>	<b>7</b>	<b>1</b>	<b>88</b>
<b>TOTAL</b>	<b>73</b>	<b>89</b>	<b>15</b>	<b>3</b>	<b>180</b>

**REMINDER: Sufficient working must be shown to demonstrate the MATHEMATICAL method employed.**

**SECTION A: STATISTICS**

- 1. The table opposite shows the destination from school of 180 year 11 pupils. Most pupils either continued education, in school or college, or went into some form of employment.**

**A reporter selects two pupils at random to interview. Given that the first pupil is in school or college, find the probability that both pupils are girls. [3 marks]**

**(Turn over)**

---

---

---

---

---

---

---

---

---

---

---

---

---

---

---

---

---

---

---

---

---

---

---

**(Turn over)**



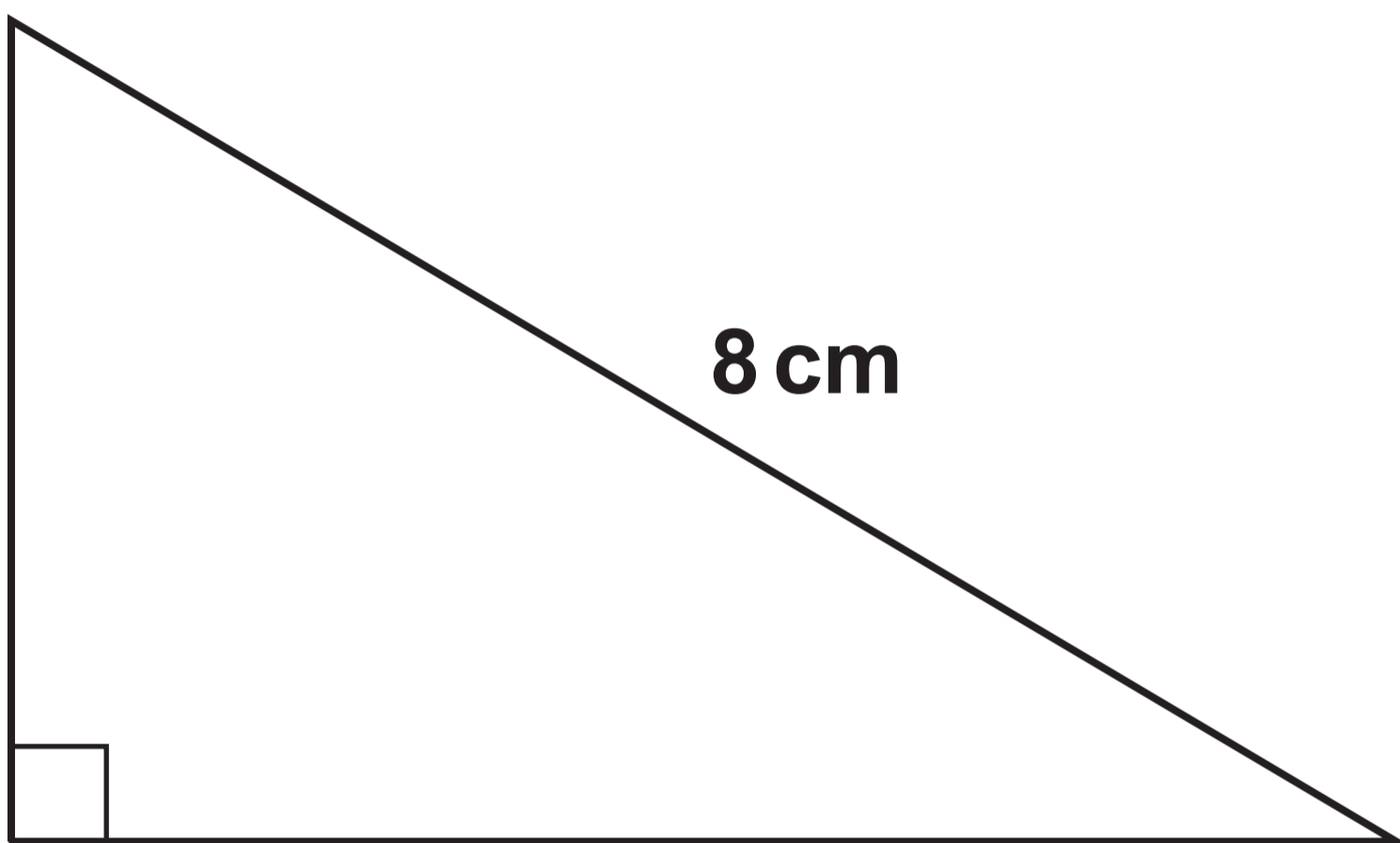

**2. The smallest angle  $\theta$  in degrees, of a right-angled triangle with hypotenuse 8 cm is uniformly distributed across all possible values.**

**(a) Find the mean and standard deviation of  $\theta$  [3 marks]**

---

---

---

---

---

---

---

---

---

---

---

**(Turn over)**



**10**

---

---

---

**(Turn over)**



**12**

---

---

---

---

---

---

---

---

---

---

---

---

---

---

---

---

---

---

---

---

---

---

---

---

**(Turn over)**





**Forearm girth**



**Bicep girth**

**3. Awena has a large data set of body measurements, and she wants to investigate relationships between body dimensions. In this particular investigation, she is testing for a correlation between forearm girth and bicep girth. The diagrams opposite show how to measure these.**

**(a) Why is it appropriate for Awena to use a one-tailed test? [1 mark]**

---

---

---

---

---

---

---

---

**(Turn over)**

---

---

---

---

---

---

---

---

---

---

# FOREARM GIRTH VERSUS BICEP GIRTH

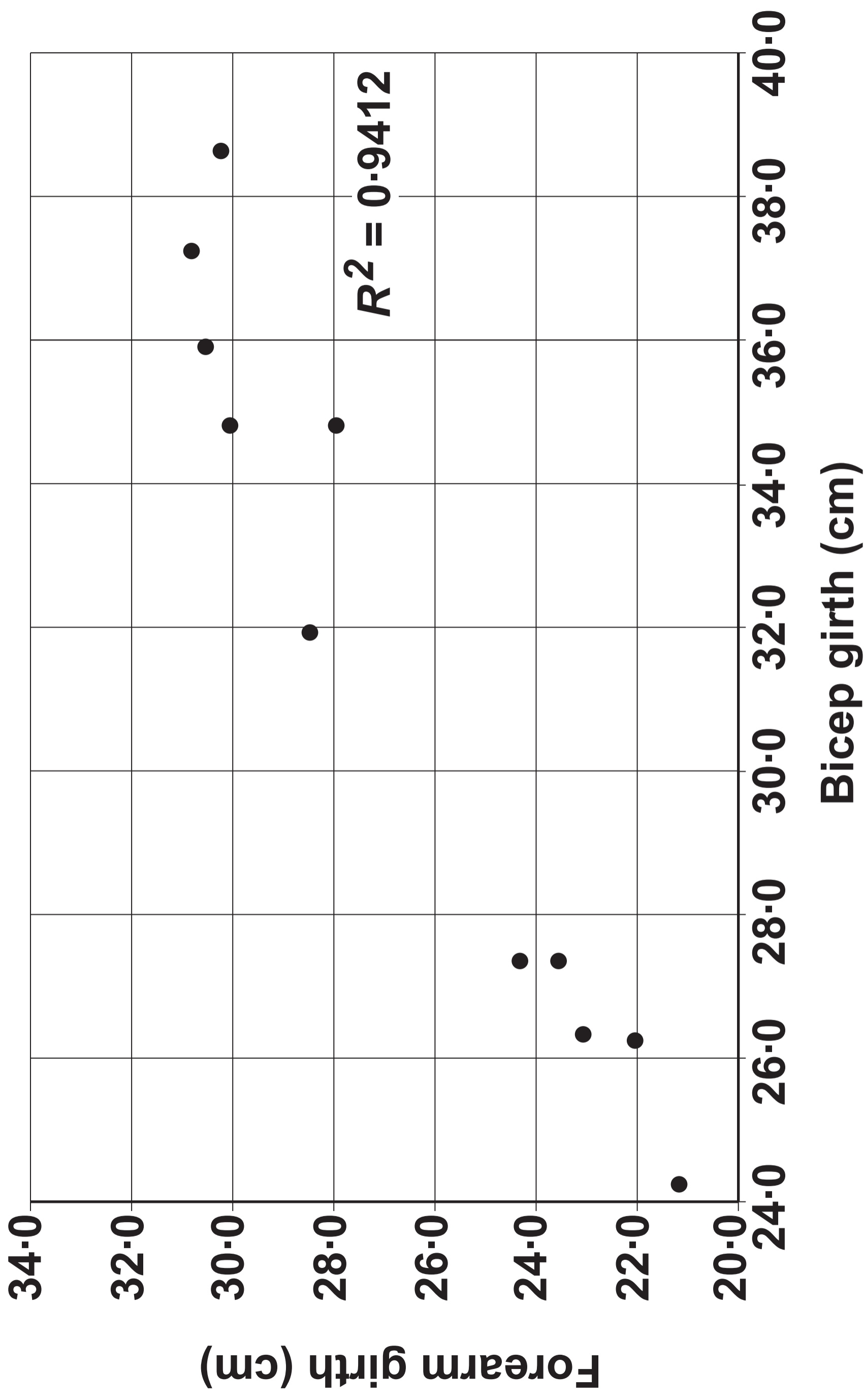

**Awena takes a random sample of size 11 from her data set and plots the scatter diagram opposite.**

**3 (b) Using the computer output opposite, carry out a one-tailed significance test on the sample product moment correlation coefficient at the 0.5% level. [5 marks]**

---

---

---

---

---

---

---

---

---

---

---

**(Turn over)**

---

---

---

# FOREARM GIRTH VERSUS BICEP GIRTH

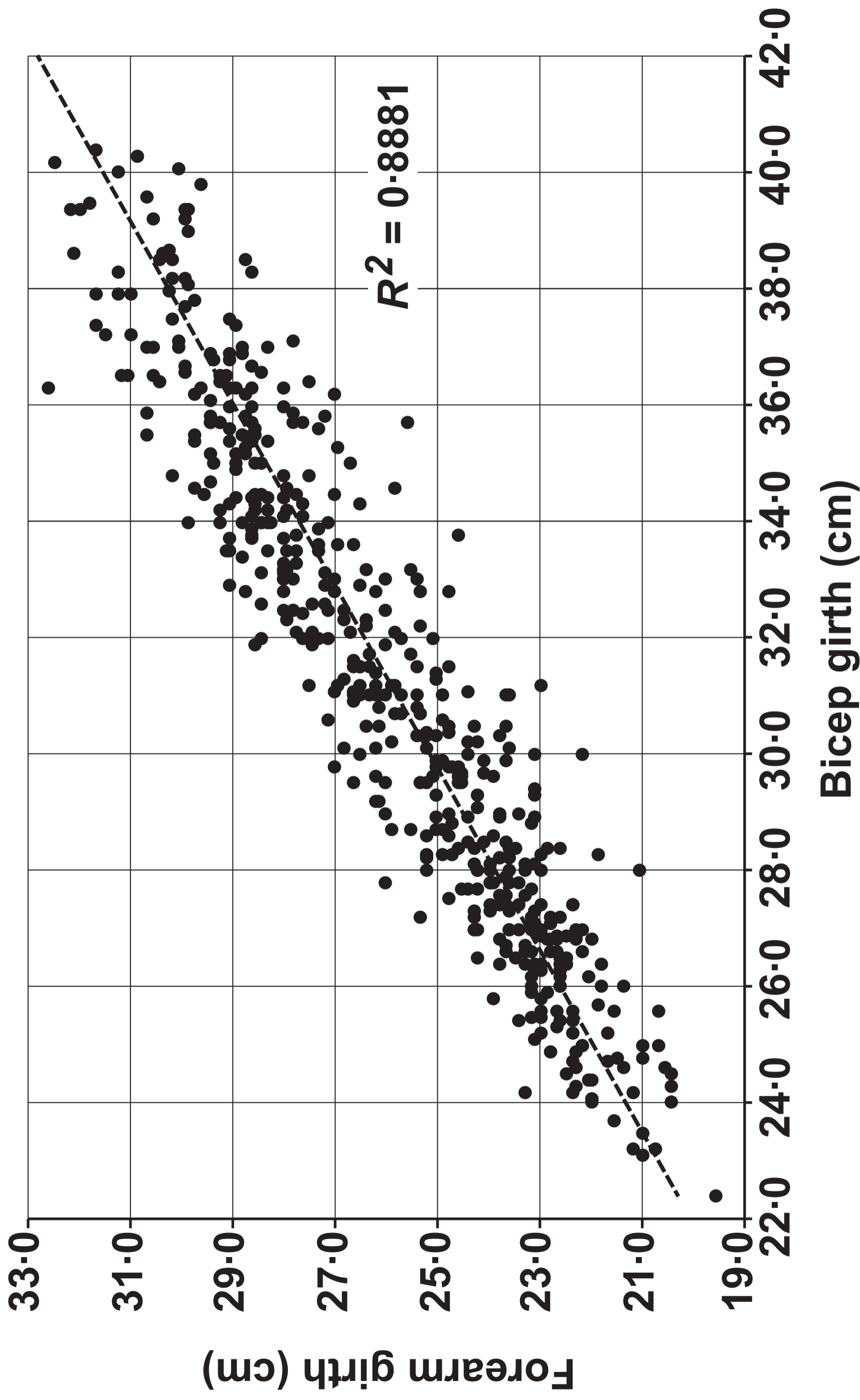

**3 (c) Blodwen also has access to the same large data set. She decides to do the same test using all of the 507 available data points. Her results are shown opposite.**

**(i) State the problem Blodwen will encounter when attempting to use statistical tables for her test.**

**(ii) How should Blodwen deal with this problem? [2 marks]**

---

---

---

---

---

---

---

---

---

---

---

---

---

---

---

---

---

---

---

---

---

---

---

---

---

---

---

---

---

---

---

---

**(Turn over)**

4. Jake works for a parcel delivery company. The masses, in kilograms, of parcels he delivers are normally distributed with mean  $2.2$  and standard deviation  $0.3$
- (a) Calculate the probability that a randomly selected parcel will have a mass less than  $1.8$  kg [2 marks]

---

---

---

---

---

---

---

---

---

---

---

---

---

---

---

---

---

---

---

---

**Jake delivers the lightest 80% of parcels on his bike. The rest he puts in his car and delivers by car.**

**4 (b) Find the mass of the heaviest parcel he would deliver by bike. [2 marks]**

---

---

---

---

---

---

---

---

---

---

---

---

---

---

---

---

---

---

---

---

---

---

---

---

**(Turn over)**

---

---

---

---

---

---

---

---

---

---

---

**4 (c) He randomly selects a parcel from his car. Find the probability that it has a mass less than 3 kg**

**[4 marks]**

---

---

---

---

---

---

---

---

---

---

---

---

---

---

---

---



---

---

---

---

---

---

---

---

---

---

---

---

---

---

---

---

---

---

---

---

**(Turn over)**

**4 (d) In the run-up to Christmas, Jake believes that the parcels he has to deliver are, on average, heavier. He assumes that the standard deviation is unchanged. He randomly selects 20 parcels and finds that their total mass is 46 kg. Test Jake's belief at the 5% level of significance. [7 marks]**

---

---

---

---

---

---

---

---

---

---

**(Turn over)**

---

---

---

---

---

---

---

---

---

---

---

---

---

---

---

---

---

---

---

---

---

---

---

---

---

---

---

(Turn over)



Jake delivers each parcel to one of three areas, ***A***, ***B*** or ***C***

The probabilities that a parcel has destination area ***A***, ***B*** and ***C***

are  $\frac{1}{2}$ ,  $\frac{1}{6}$  and  $\frac{1}{3}$  respectively. All parcels are considered to be independent.

- 4 (e) On a particular day, Jake has three parcels to deliver. Find the probability that he will have to deliver to all three areas. [2 marks]

---

---

---

---

---

---

---

---

---

---

---

---

---

---

---

**4 (f) On a different day, Jake has two parcels to deliver. Find the probability that he will have to deliver to more than one area.**

**[4 marks]**

---

---

---

---

---

---

---

---

---

---

---

---

---

---

---

---

---

---

---

---

---

---

---

---

---

**(Turn over)**



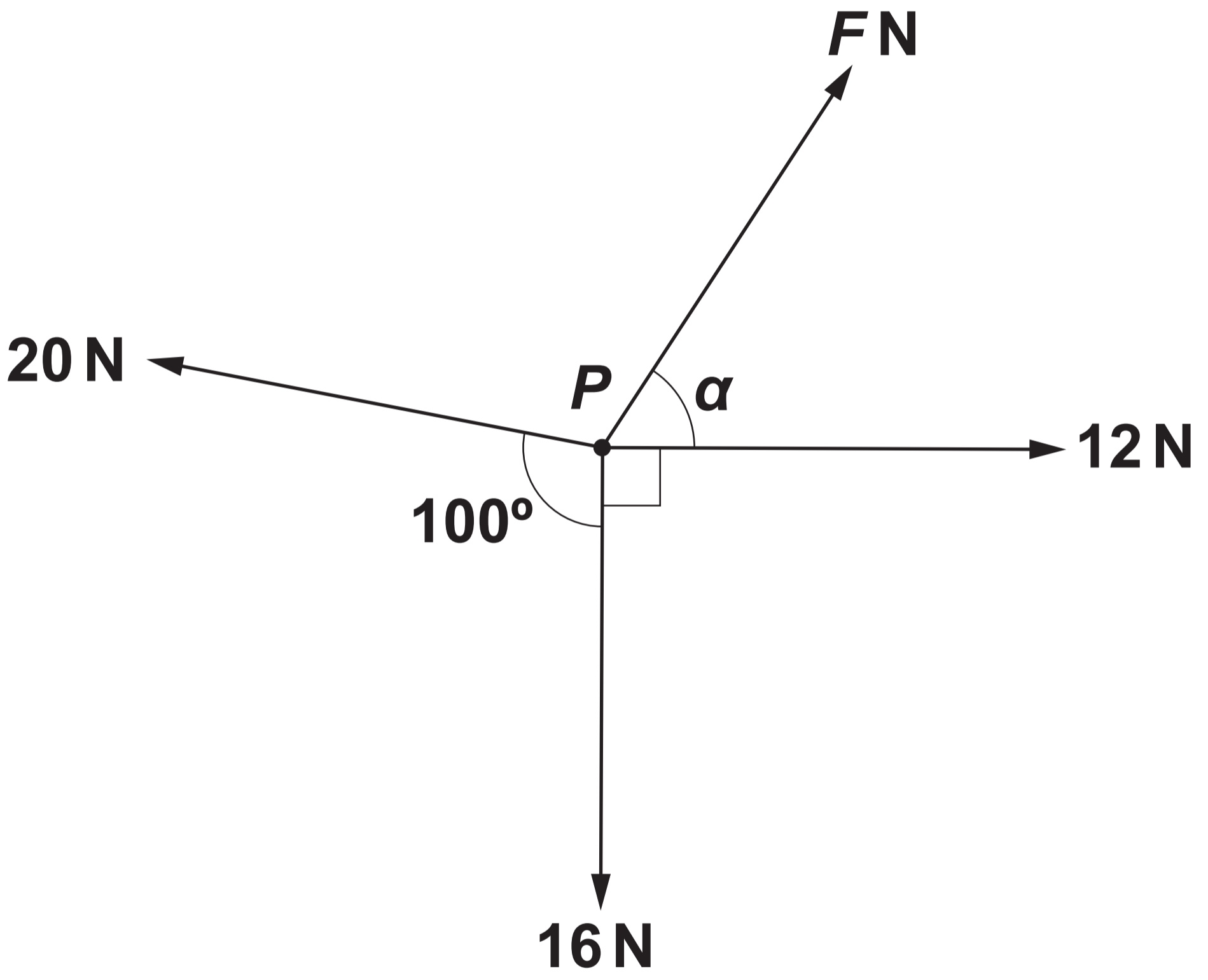

**SECTION B: DIFFERENTIAL EQUATIONS  
AND MECHANICS**

5. The diagram opposite shows four coplanar horizontal forces of magnitude  $F$  N, 12 N, 16 N and 20 N acting at a point  $P$  in the directions shown.

Given that the forces are in equilibrium, calculate the value of  $F$  and the size of the angle  $\alpha$

[7 marks]

---

---

---

---

---

---

(Turn over)







6. A ball is projected with velocity  $(4w\mathbf{i} + 7w\mathbf{j})\text{ms}^{-1}$  from the top of a vertical tower. After 5 seconds, the ball hits the ground at a point that is 60 m horizontally from the foot of the tower.

The unit vectors  $\mathbf{i}$  and  $\mathbf{j}$  are horizontal and vertical respectively.

- (a) Find the value of  $W$  and hence determine the height of the tower.

[5 marks]

---

---

---

---

---

---

---

---

---

---

(Turn over)





---

---

---

---

---

---

---

---

**6 (b) Determine the proportion of the 5 seconds for which the ball is on its way down. [3 marks]**

---

---

---

---

---

---

---

---

---

---

---

---

---

---

---

---

---

---

---

---

---

---

---

---

**(Turn over)**

---

---

---

---

---

---

---

---

---

---

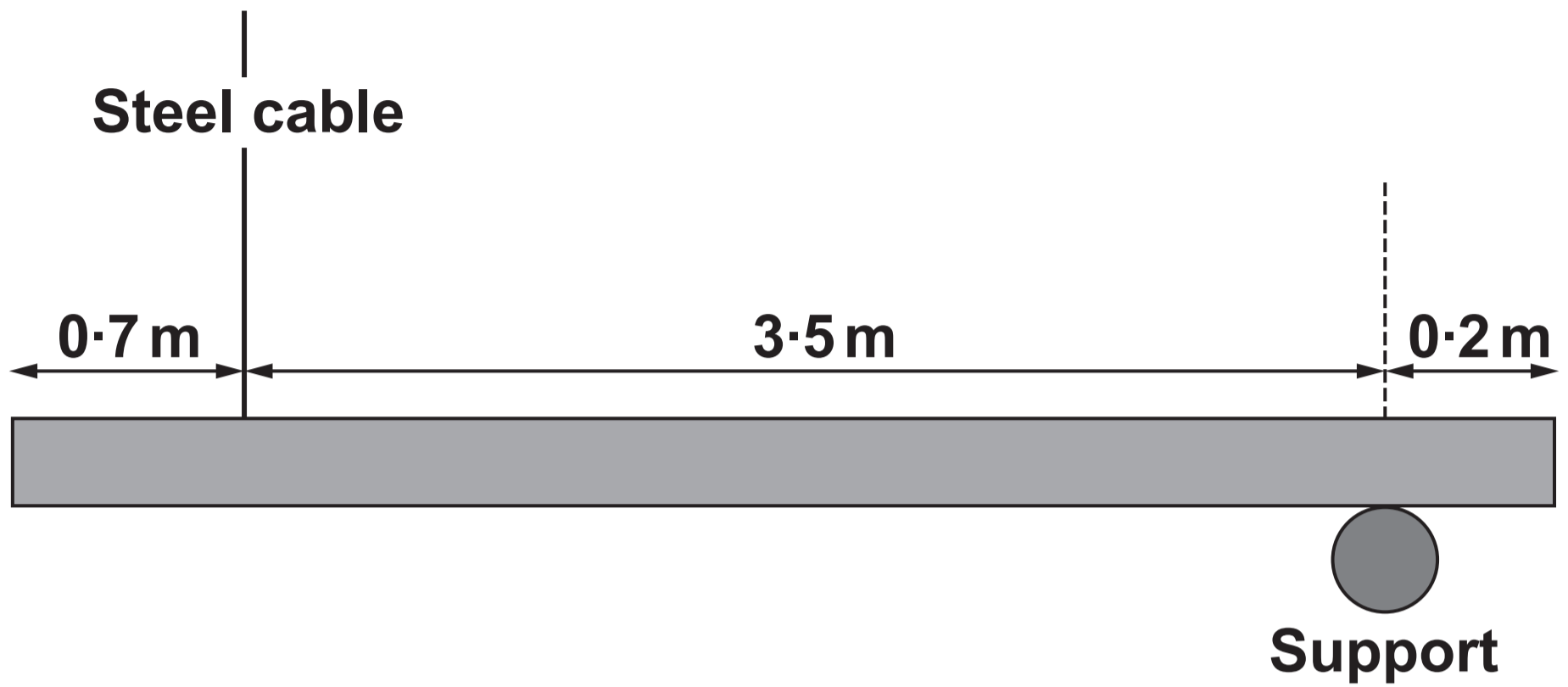

<b>STEEL CABLE</b>	
<b>Category</b>	<b>Supports forces up to (N)</b>
<b>A</b>	<b>3000</b>
<b>B</b>	<b>2500</b>
<b>C</b>	<b>2000</b>

**You may use the following modelling assumptions.**

- **The wooden beam is a rigid uniform rod of mass  $100\text{ kg}$**
- **The force exerted on the beam by the support is vertical.**
- **The steel cable is inextensible.**

## **SAFETY REQUIREMENT**

**Both the steel cable and the support must be capable of withstanding forces of AT LEAST FOUR TIMES those present in the architect's diagram opposite.**

- 7. As part of a design for a new building, an architect wants to support a wooden beam in a horizontal position. The beam is suspended using a vertical steel cable and a smooth fixed support on its underside. The diagram on the previous page shows the architect's diagram and the table shows the categories of steel cable available.**

**The wooden beam is held in horizontal equilibrium.**

**(a) (i)**

**Given that the support is capable of withstanding loads of up to  $2000\text{ N}$  show that the force exerted on the beam by the support satisfies the safety requirement. [3 marks]**

**(Turn over)**

**7 (a) (continued)**

**(ii) Determine which categories of steel cable in the table could meet the safety requirements. [3 marks]**

---

---

---

---

---

---

---

---

---

---

---

---

---

---

---

---

---

---

---

---

---

---

---

**(Turn over)**



---

---

---

---

---

---

---

---

---

---

---

---

---

---

---

---

---

---

---

---

---

---

---

---

---

---

**(Turn over)**

---

---

---

**7 (b) State how you have used the modelling assumption that the beam is a uniform rod. [1 mark]**

---

---

---

---

---

---

---

---

---

---

---

---

8. Three forces  $\underline{F}_1$ ,  $\underline{F}_2$  and  $\underline{F}_3$  are acting on an object of mass 3 kg such that

$$\underline{F}_1 = (\underline{i} + 8c\underline{j} + 11c\underline{k}) \text{ N}$$

$$\underline{F}_2 = (-14\underline{i} - c\underline{j} - 12\underline{k}) \text{ N}$$

$$\underline{F}_3 = ((15c + 1)\underline{i} + 2c\underline{j} - 5c\underline{k}) \text{ N}$$

where  $C$  is a constant. The acceleration of the object is parallel to the vector  $(\underline{i} + \underline{j})$

**8 (a) Find the value of the constant  $C$  and hence show that the acceleration of the object is  $(6\mathbf{i} + 6\mathbf{j}) \text{ms}^{-2}$**

**[4 marks]**

---

---

---

---

---

---

---

---

---

---

---

---

---

---

---

---

---

---

---

---

---

---

---

---





8 (b) When  $t = 0$  seconds, the object has position vector  $\underline{r}_0$  m and is moving with velocity  $(-17\underline{i} + 8\underline{j}) \text{ ms}^{-1}$

When  $t = 4$  seconds, the object has position vector  $(-13\underline{i} + 84\underline{j}) \text{ m}$

Find the vector  $\underline{r}_0$  [3 marks]

---

---

---

---



---

---

---

---

---

---

---

---

---

---

---

---

---

---

---

---

---

---

---

---

---

---

---

---

---

---

---

---

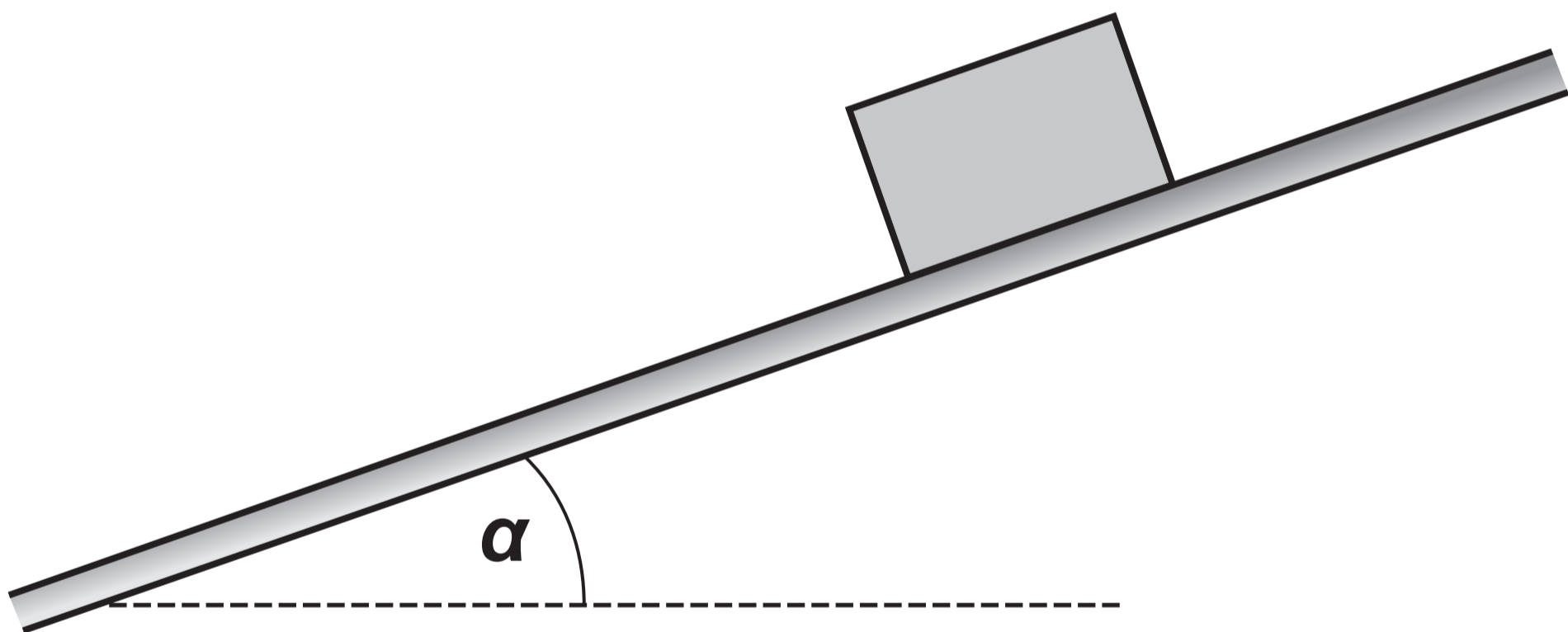

9. The diagram opposite shows a parcel, of mass  $m$  kg, sliding down a rough slope inclined at an angle  $\alpha$  to the horizontal, where

$$\sin \alpha = \frac{7}{25}$$

The coefficient of friction between the parcel and the slope is  $\frac{1}{12}$

In addition to friction, the parcel experiences a variable resistive force of  $mv$  N where  $v$  ms<sup>-1</sup> is the velocity of the parcel at time  $t$  seconds.

- (a) Show that the motion of the parcel satisfies the differential equation

$$5 \frac{dv}{dt} = g - 5v$$

[5 marks]

(Turn over)

---

---

---

---

---

---

---

---

---

---

---

---

---

---

---

---

---

---

---

---

---

---

---

---

---



**9 (b) Given that the parcel is initially at rest on the slope, find an expression for  $V$  in terms of  $t$  and  $g$  [5 marks]**

---

---

---

---

---

---

---

---

---

---

---

---

---

---

---

---

---

---

---

---

---

---

---

---



---

---

---

---

---

---

---

**9 (c)** To avoid damage, the speed of the parcel must be restricted to a maximum of  $2\text{ ms}^{-1}$  down the slope. Determine whether or not the speed of the parcel exceeds  $2\text{ ms}^{-1}$   
[1 mark]

---

---

---

---

---

---

---

---

---

---

---

---

---

---

---

---

---

---

---

---

---

---

---

---

---

<b>Question number</b>	<b>Additional page, if required. Write the question numbers in the left-hand margin.</b>
	<hr/> <hr/> <hr/> <hr/> <hr/> <hr/> <hr/> <hr/> <hr/> <hr/> <hr/> <hr/> <hr/> <hr/> <hr/> <hr/> <hr/> <hr/> <hr/> <hr/> <hr/> <hr/> <hr/>

<b>Question number</b>	<b>Additional page, if required.</b> <b>Write the question numbers in the left-hand margin.</b>
	<hr/> <hr/> <hr/> <hr/> <hr/> <hr/> <hr/> <hr/> <hr/> <hr/> <hr/> <hr/> <hr/> <hr/> <hr/> <hr/> <hr/> <hr/> <hr/> <hr/> <hr/> <hr/>



