



GCSE

3310U50 – 1

THURSDAY, 9 MAY 2024 – MORNING

MATHEMATICS – NUMERACY

UNIT 1: NON – CALCULATOR

HIGHER TIER

1 hour 45 minutes plus your additional time allowance

THE USE OF A CALCULATOR IS NOT PERMITTED IN THIS EXAMINATION

Surname: _____

First name(s): _____

Centre Number: _____

Candidate Number: 0 _____

For Examiner's use only		
Question	Maximum Mark	Mark Awarded
1.	6	
2.	6	
3.	9	
4.	9	
5.	11	
6.	9	
7.	10	
8.	5	
9.	11	
10.	4	
Total	80	

(Turn over)

ADDITIONAL MATERIALS

A ruler, a protractor and a pair of compasses may be required.

ITEMS INCLUDED WITH QUESTION PAPER

A separate Formula List.

A separate Diagram Booklet.

Model for Question 6 (a).

The Diagram Booklet MUST be handed in to the invigilators and sent for marking.

INSTRUCTIONS TO CANDIDATES

Use black ink, black ball – point pen, black felt tip or your usual method.

Write your name, centre number and candidate number in the spaces on the front cover.

Answer ALL questions.

Write your answers in the spaces provided.

If you run out of space, use the additional page(s) at the back of the booklet.

Question numbers must be given for the work written on the additional page(s).

Take π as $3 \cdot 14$

INFORMATION FOR CANDIDATES

You should give details of your method of solution when appropriate.

Unless stated, diagrams are not drawn to scale.

Scale drawing solutions will not be acceptable where you are asked to calculate.

The number of marks is given in brackets at the end of each question or part – question.

In question 1, the assessment will take into account the quality of your linguistic and mathematical organisation, communication and accuracy in writing.

(Turn over)

1. IN THIS QUESTION, YOU WILL BE ASSESSED ON THE QUALITY OF YOUR ORGANISATION, COMMUNICATION AND ACCURACY IN WRITING.

Look at the diagram for Question 1 in the separate Diagram Booklet.

The diagram is a pie chart.

7200 spectators at a sports event were asked their nationality.

The results are displayed in the pie chart.

For the Welsh spectators, the ratio of the number of adults to the number of children was 6 : 5

How many adult Welsh spectators were at the event?

You must show all your working.

2. Look at the diagram for Question 2 in the separate Diagram Booklet.

The diagram is a scatter diagram.

Some houses in a village have new driveways laid by DriveDown.

The scatter diagram shows the area and cost of each driveway.

(a) Look at the diagram for Question 2 (a) in the separate Diagram Booklet.

The diagram is NOT drawn to scale.

The measurements of Gwenda's driveway are shown in the diagram.

Consider the exact area of Gwenda's driveway.

Calculate an estimate of how much it would cost Gwenda to have a new driveway laid by DriveDown.

You must show all your working.

[4 marks]

continued on the next page . . .

(Turn over)

Question 2 continued

2. (b) Tanya's driveway covers an area of 23 m^2 . She decides to have her driveway repaired instead of having a new driveway.

Tanya thinks the repair will cost her 40% of the estimated cost of having a new driveway laid by DriveDown.

She has budgeted £575 for the repair of her driveway.

Will Tanya's budget cover the cost of repairing her driveway?

Yes No

You must show all your working and give a reason for your answer.

(Turn over)

10

[2 marks]

(Turn over)

3. (a) Look at the diagram for Question 3 (a) in the separate Diagram Booklet.

The diagram IS drawn to scale.

Josif produces a scale drawing to show where he wants a tree planted in his garden. He writes out instructions to show where the tree is to be planted.

Which TWO of the following instructions describe where the tree is to be planted?

- A. The tree must be 4 metres from the hedge.
- B. The tree must be 2 metres from the hedge.
- C. The tree must be 12 metres from the hedge.
- D. The tree must be 6 metres from the hedge.
- E. The tree must be 2 metres from the wall.

continued on the next page . . .

(Turn over)

Question 3 (a) continued

- F. The tree must be equidistant from the hedge and the fence.**
 - G. The tree must be equidistant from the hedge and the wall.**
 - H. The tree must be equidistant from the wall and the house.**
 - I. The tree must be equidistant from the hedge and the house.**
 - J. The tree must be equidistant from the wall and the fence.**
-
-
-

The two instructions are

_____ and _____

[2 marks]

continued on the next page . . .

(Turn over)

Question 3 continued

3. (b) A garden centre buys trees from a grower for £30 each.

The garden centre sells the trees for £42 each.

(i) Calculate the percentage profit the garden centre makes from buying and selling one tree.

[2 marks]

continued on the next page . . .

(Turn over)

Question 3 (b) continued

3. (b) (ii) The garden centre buys 10 of these trees to sell.

One of the trees gets damaged and cannot be sold.

The other 9 trees are sold.

Calculate the overall percentage profit or loss the garden centre makes from selling these trees.

You must state whether your answer is a profit or a loss.

You must show all your working.

[4 marks]

continued on the next page . . .

(Turn over)

Question 3 (b) continued

3. (b) (iii) Of the **10** trees bought by the garden centre, what is the minimum number that need to be sold to ensure that the garden centre makes a profit?

Circle your answer.

5	6	7	8	9
----------	----------	----------	----------	----------

[1 mark]

(Turn over)

4. (a) Look at the diagram for Question 4 (a) in the separate Diagram Booklet.

The diagram is a cumulative frequency diagram.

On **1st June** last year, **200** customers used cash to pay at Shop Lil.

The cumulative frequency diagram represents the time each of these **200** customers waited to be given change at the checkout.

(i) How many of these customers waited between **30** and **50** seconds for their change?

[2 marks]

continued on the next page . . .

(Turn over)

Question 4 (a) continued

4. (a) (ii) Use the graph to estimate the median time these **200** customers waited for their change.

Circle your answer.

30 seconds
34 seconds
36 seconds
50 seconds
100 seconds

[1 mark]

continued on the next page . . .

(Turn over)

Question 4 (a) continued

- 4. (a) (iii) Calculate the fraction of these 200 customers who waited 40 seconds or longer for their change.
Give your answer in its simplest form.**

[2 marks]

continued on the next page . . .

(Turn over)

Question 4 continued

4. (b) Look at the diagram for Question 4 (b) in the separate Diagram Booklet.

The diagram is a box – and – whisker plot.

On **1st June** this year, the manager at Shop Lil drew this box – and – whisker plot of the times **200** customers waited for their change at the checkout.

Based on the results of these **200** customers, the manager made the following statements.

Complete the statements.

- (i) “On 1st June this year, 50% of our customers were given their change in _____ seconds or less.”

[1 mark]

continued on the next page . . .

(Turn over)

Question 4 (b) continued

4. (b) (ii) “On 1st June this year, the interquartile range of the times taken to give customers their change was _____ seconds.”

[2 marks]

continued on the next page . . .

(Turn over)

Question 4 continued

4. (c) Consider the **50** customers waiting the **LONGEST** times to get their change on **1st June** last year and this year.

Has the speed of giving change at the checkout improved since last year?

Yes No

You must give a reason for your answer.

[1 mark]

(Turn over)

5. (a) The area of Wales is $20\,735\text{ km}^2$

The table below gives the population of Wales in 1977, 1998 and 2015.

YEAR	POPULATION
1977	2.8 million
1998	2.9 million
2015	3.1 million

- (i) What was the increase in the population of Wales between 1977 and 1998?

Circle your answer.

1×10^3	1×10^4	1×10^5	1×10^6	1×10^7
-----------------	-----------------	-----------------	-----------------	-----------------

[1 mark]

continued on the next page ...

(Turn over)

Question 5 continued

5. (b) Cardiff is the largest city in Wales.

In 2018, the population of Cardiff was approximately 360 000

The population of Cardiff increased by 20% from 1991 to 2018.

Calculate the population of Cardiff in 1991.

[3 marks]

continued on the next page . . .

(Turn over)

Question 5 continued

5. (c) Look at the diagrams for Question 5 (c) in the separate Diagram Booklet.

There are three diagrams.

The diagrams are NOT drawn to scale.

DraigYma prints Welsh flags onto stickers.

Three of their mathematically similar Welsh flag stickers are shown in the diagrams.

Calculate the missing length and height in the diagrams.

Length is _____ cm

Height is _____ cm

[4 marks]

6. Most aircraft are held together with metal rivets.

(a) Ask for the model for Question 6 (a).

The model is NOT made to scale.

The model represents a rivet used on one type of aircraft. It can be thought of as a cylinder connected to a hemisphere.

The cylinder has a diameter of 6 mm and a length of 9 mm.

The hemisphere has a diameter of 12 mm.

(i) Calculate the volume of the rivet.

Give your answer in terms of π in its simplest form.

[4 marks]

continued on the next page . . .

(Turn over)

7. Look at the table for Question 7 in the separate Diagram Booklet.

The headteacher of Ynysgorwen School wants to know how long it takes pupils to travel to school.

The results for a sample of 120 pupils are shown in the table.

(a) (i) Complete the frequency density column.

[3 marks]

continued on the next page . . .

(Turn over)

[4 marks]

7. (b) (ii) What is the greatest possible median travel time for the sample of pupils?

[1 mark]

(Turn over)

8. Look at the diagram for Question 8 in the separate Diagram Booklet.

The diagram is a graph.

Sian ran a 100 – metre race.

The graph shows Sian’s speed over the FIRST 8 seconds of the race.

Sian then ran the rest of the race at a constant speed of 8 m/s.

By first using the trapezium rule with 4 strips of equal width for the first 8 seconds, estimate the total time it took Sian to run the 100 – metre race.

You must show all your working.

Sian's total time to run the 100 – metre race

= _____ seconds

[5 marks]

(Turn over)

9. (a) Look at the diagram for Question 9 (a) in the separate Diagram Booklet.

Geraint has bought a new front cog for his bike.

The cog has a mass of **150 g**, correct to the nearest **10 g**.

The cog has been made from a metal that has a density of **3 g/cm³**, correct to the nearest **g/cm³**

Calculate the maximum possible volume of the cog.

(Turn over)

[3 marks]

continued on the next page . . .

(Turn over)

Question 9 continued

9. (b) Look at the diagram for Question 9 (b) in the separate Diagram Booklet.

The diagram is NOT drawn to scale.

The diagram is a simplified diagram of the cogs and the chain on Geraint's bike.

X and Y are the centres of the cogs and XY is a line of symmetry.

BC and AD are straight sections of the chain.

The larger cog has a radius of 12 cm.

The smaller cog has a radius of 2 cm.

- (i) Use Pythagoras' theorem to show that the length of AD is $10\sqrt{15}$ cm.

You must show all your working.

(Turn over)

[3 marks]

continued on the next page . . .

(Turn over)

Question 9 (b) continued

9. (b) (ii) Look at the diagram for Question 9 (b) (ii) in the separate Diagram Booklet.
The diagram is NOT drawn to scale.

In the diagram,

$$\text{Angle } AXB = 150^\circ,$$

$$\text{reflex angle } CYD = 210^\circ,$$

$$BC = AD = 10\sqrt{15} \text{ cm.}$$

Calculate the total length of the chain.

Give your answer in the form

$a\sqrt{15} + b\pi$, where a and b are rational numbers.

(Turn over)

10. **7 water pumps can fill a swimming pool in 12 hours.**

These 7 water pumps work together at the same rate.

When the pool is empty, the 7 pumps are turned on.

After working for 3 hours, 2 of the pumps are turned off.

The other pumps carry on working until the swimming pool is full.

Calculate how long in total it takes for the swimming pool to be filled.

Give your answer in hours and minutes.



GCSE

3310U50-1

THURSDAY, 9 MAY 2024 – MORNING

MATHEMATICS – NUMERACY

UNIT 1: NON – CALCULATOR

HIGHER TIER

**The Diagram Booklet MUST be handed in
to the invigilators and sent for marking.**

Diagram Booklet

Surname: _____

First name(s): _____

Centre Number: _____

Candidate Number: 0 _____

Question 1

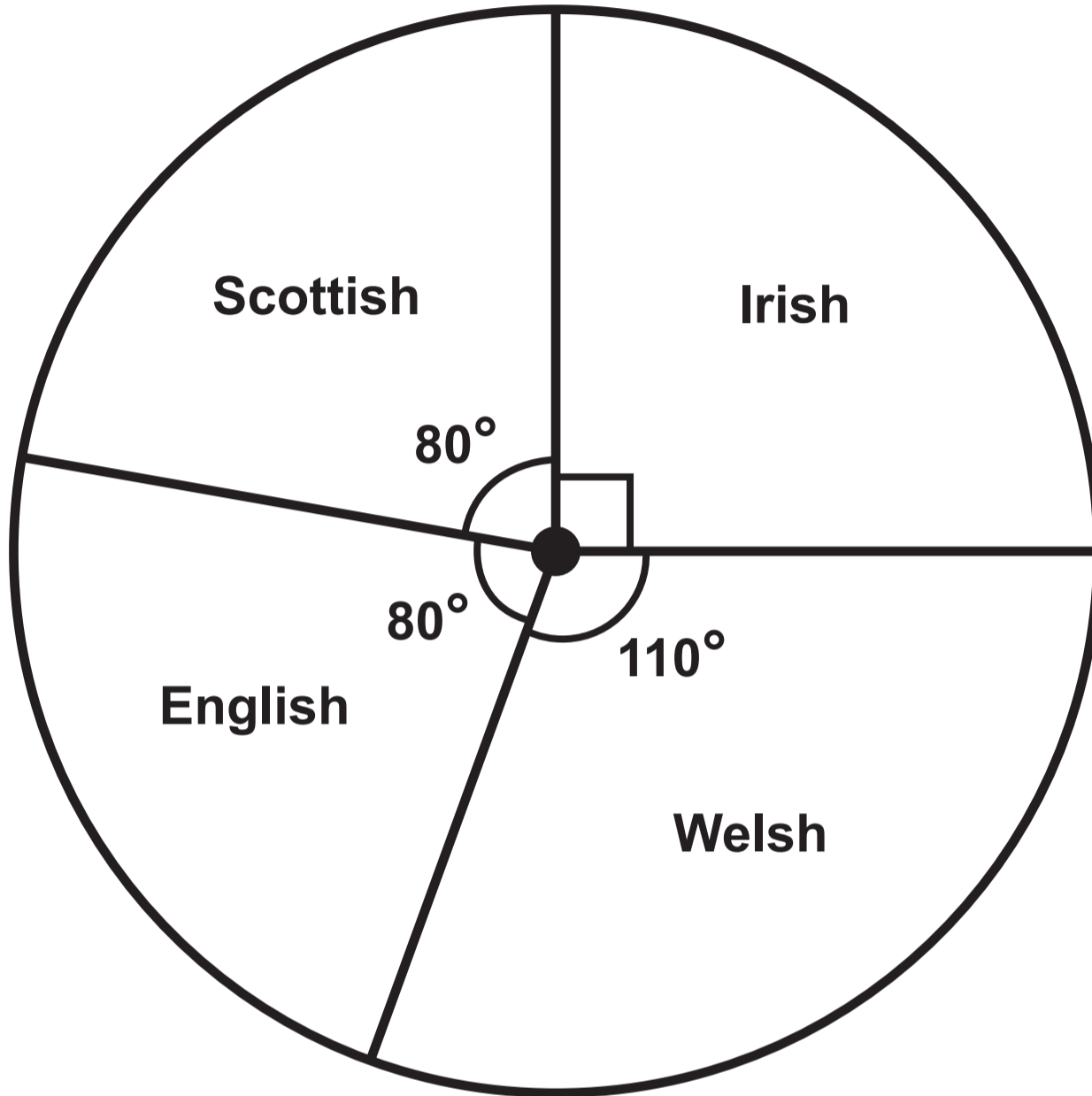

Question 2

Area of driveway (m²)

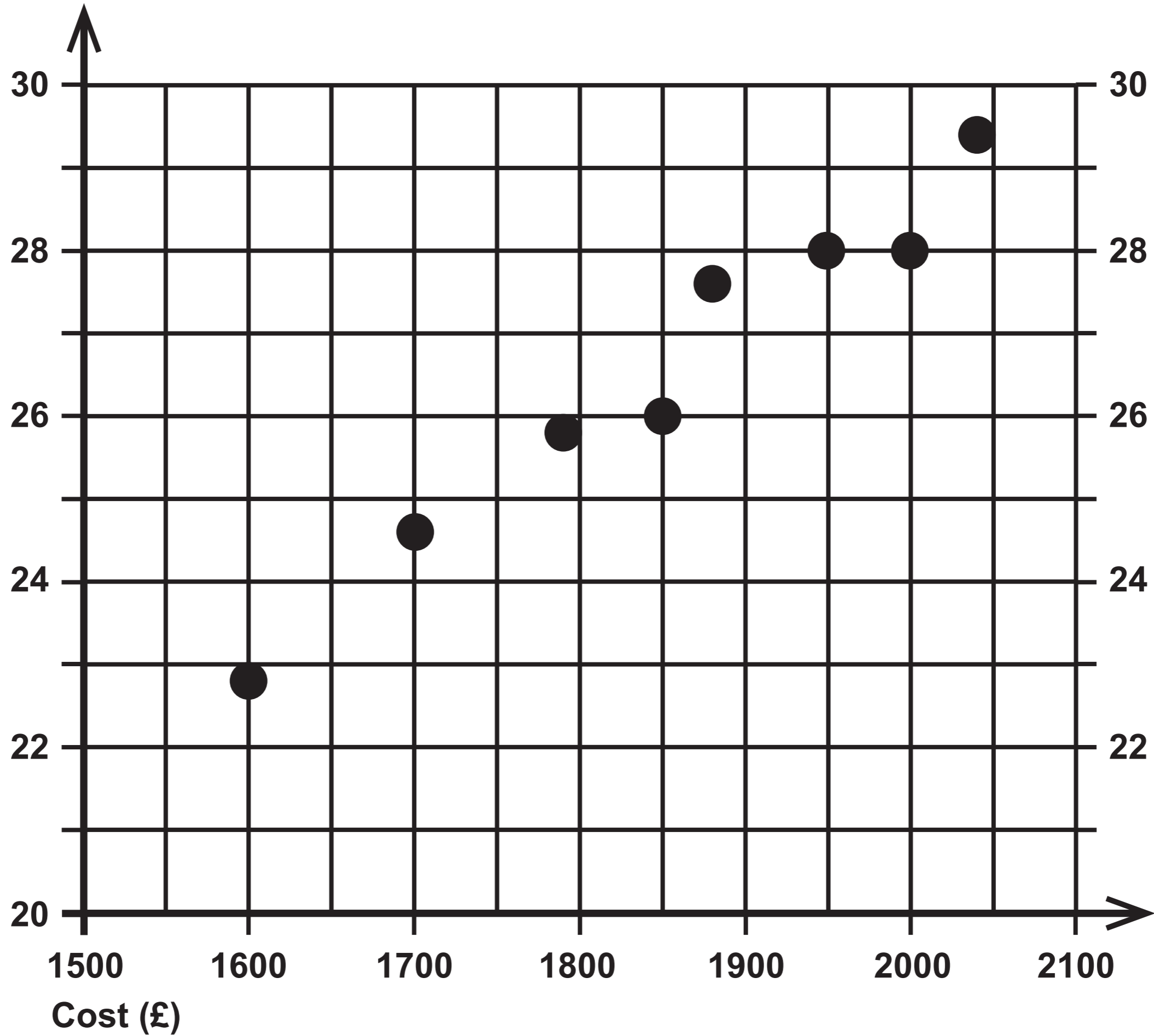

Question 2 (a)

Diagram NOT drawn to scale

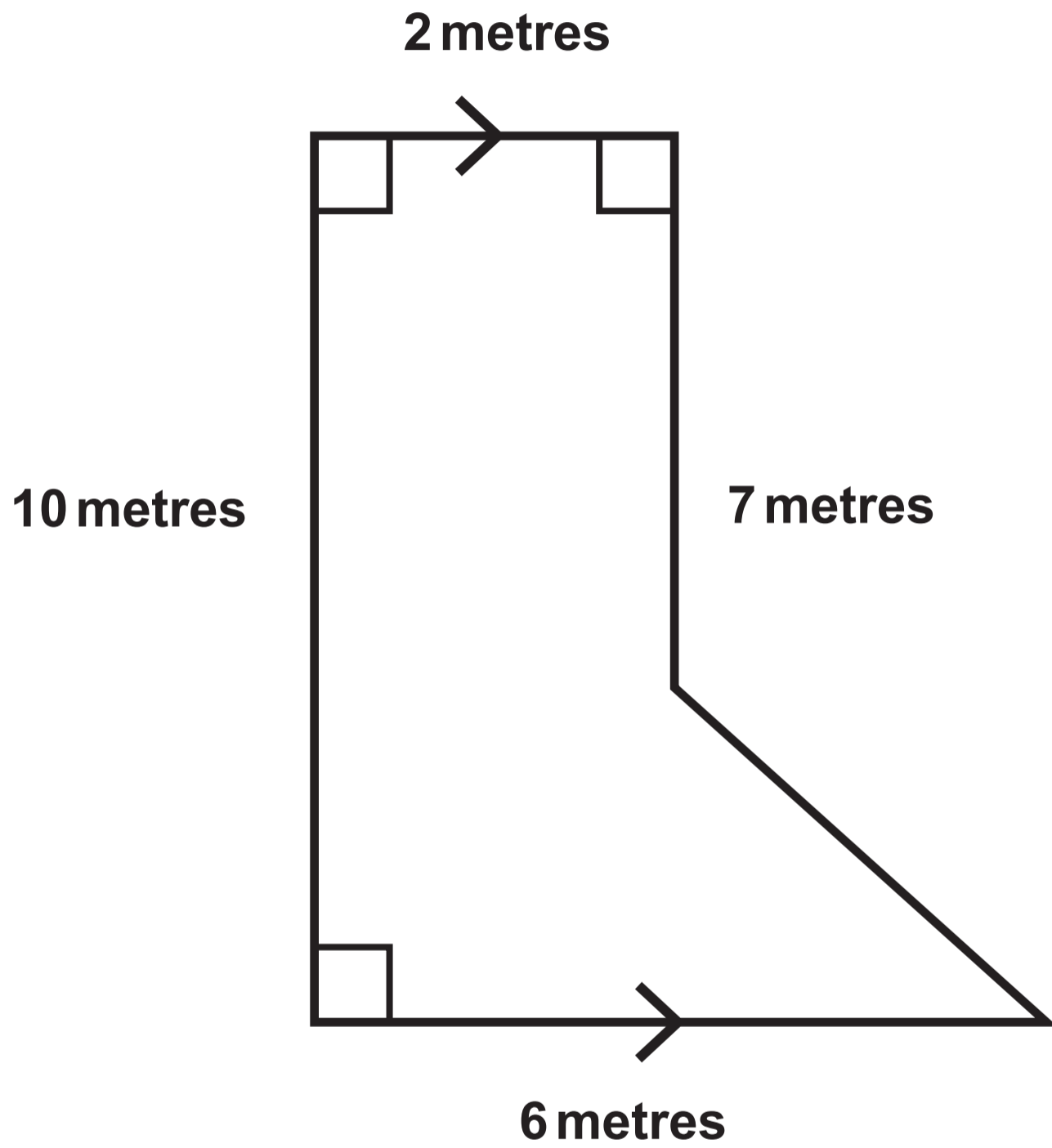

Question 3 (a)

Diagram IS drawn to scale

Scale: 1cm represents 0.5 metres

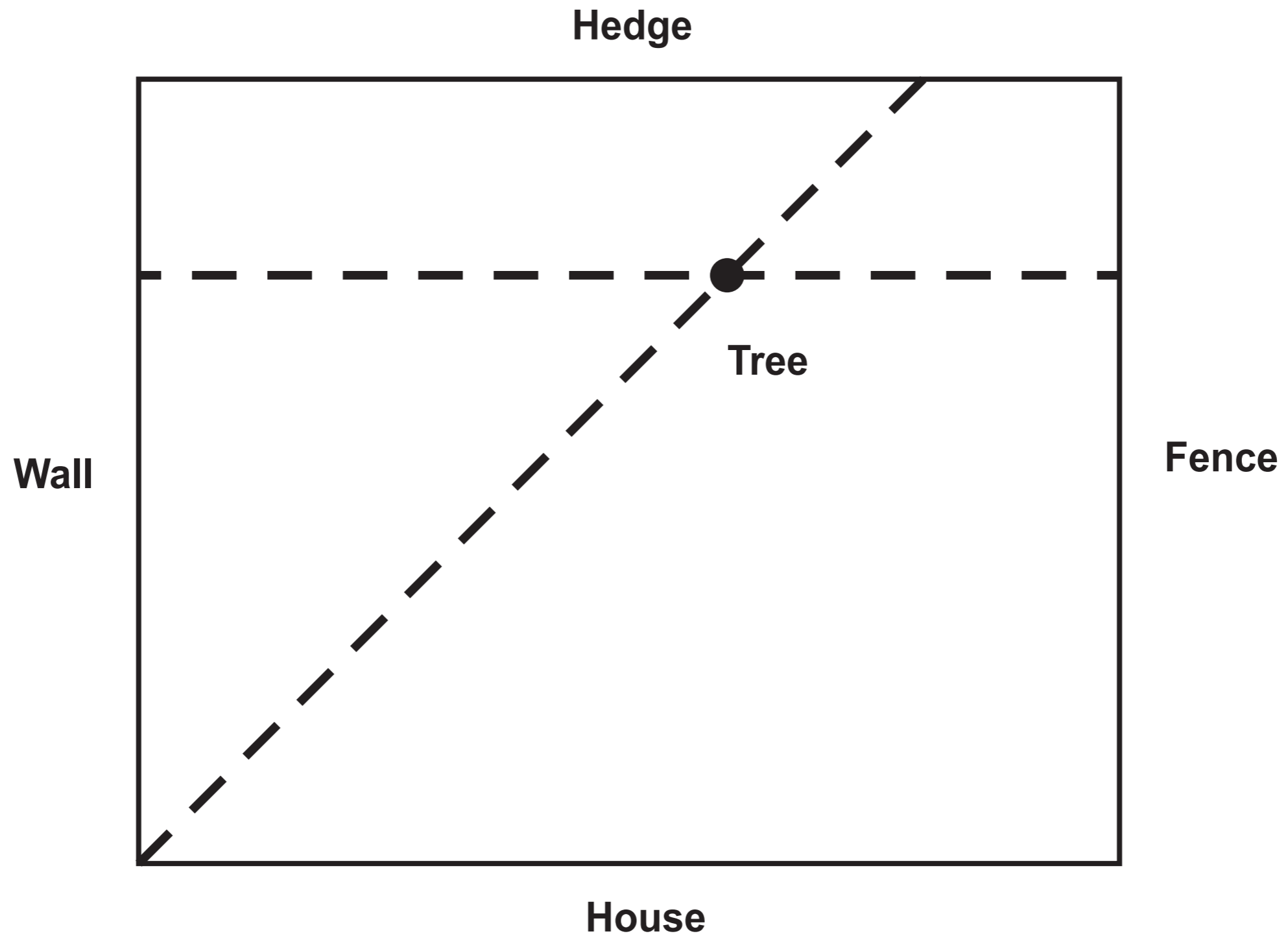

Question 4 (a)

Cumulative frequency

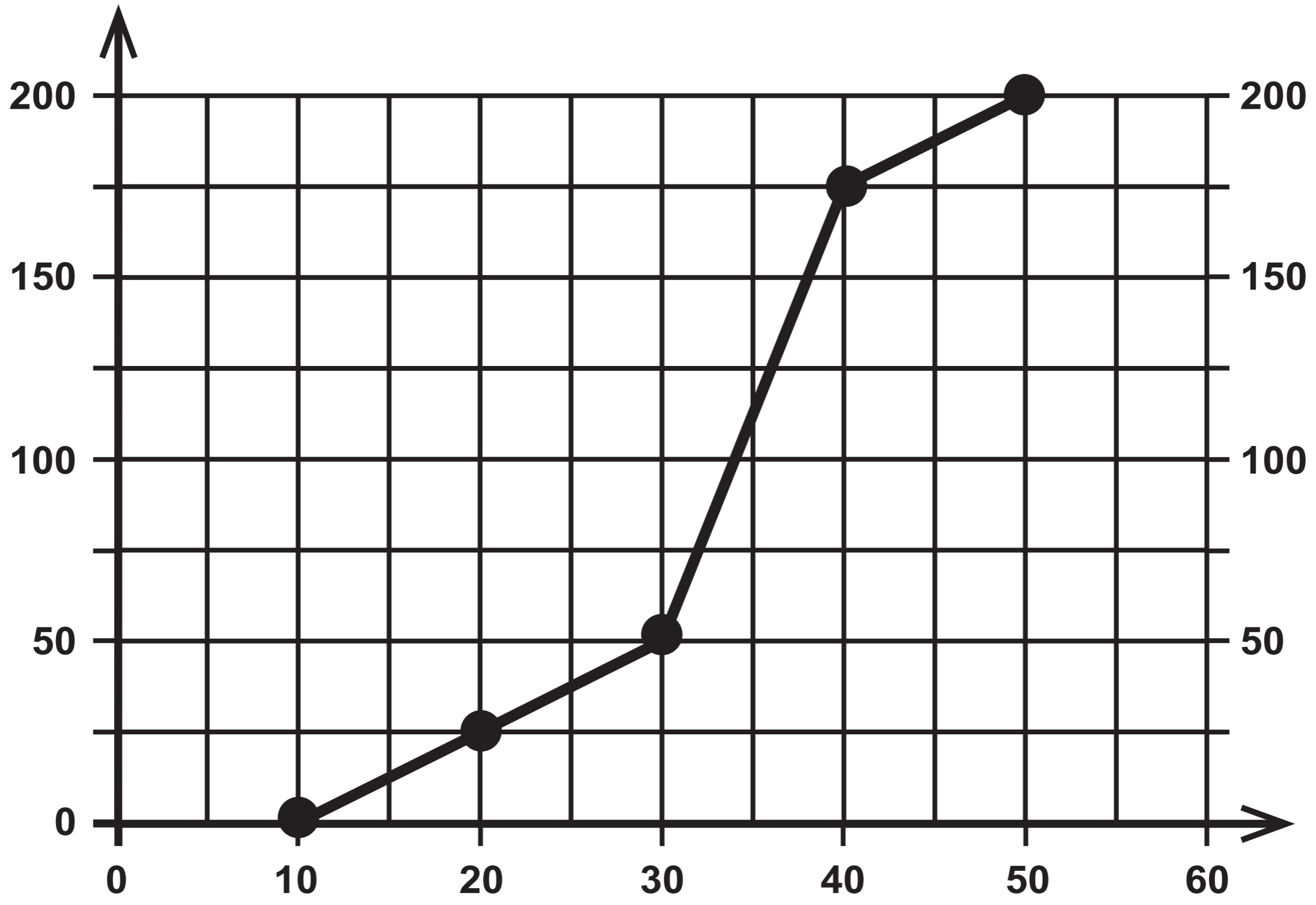

Time (s)

Question 4 (b)

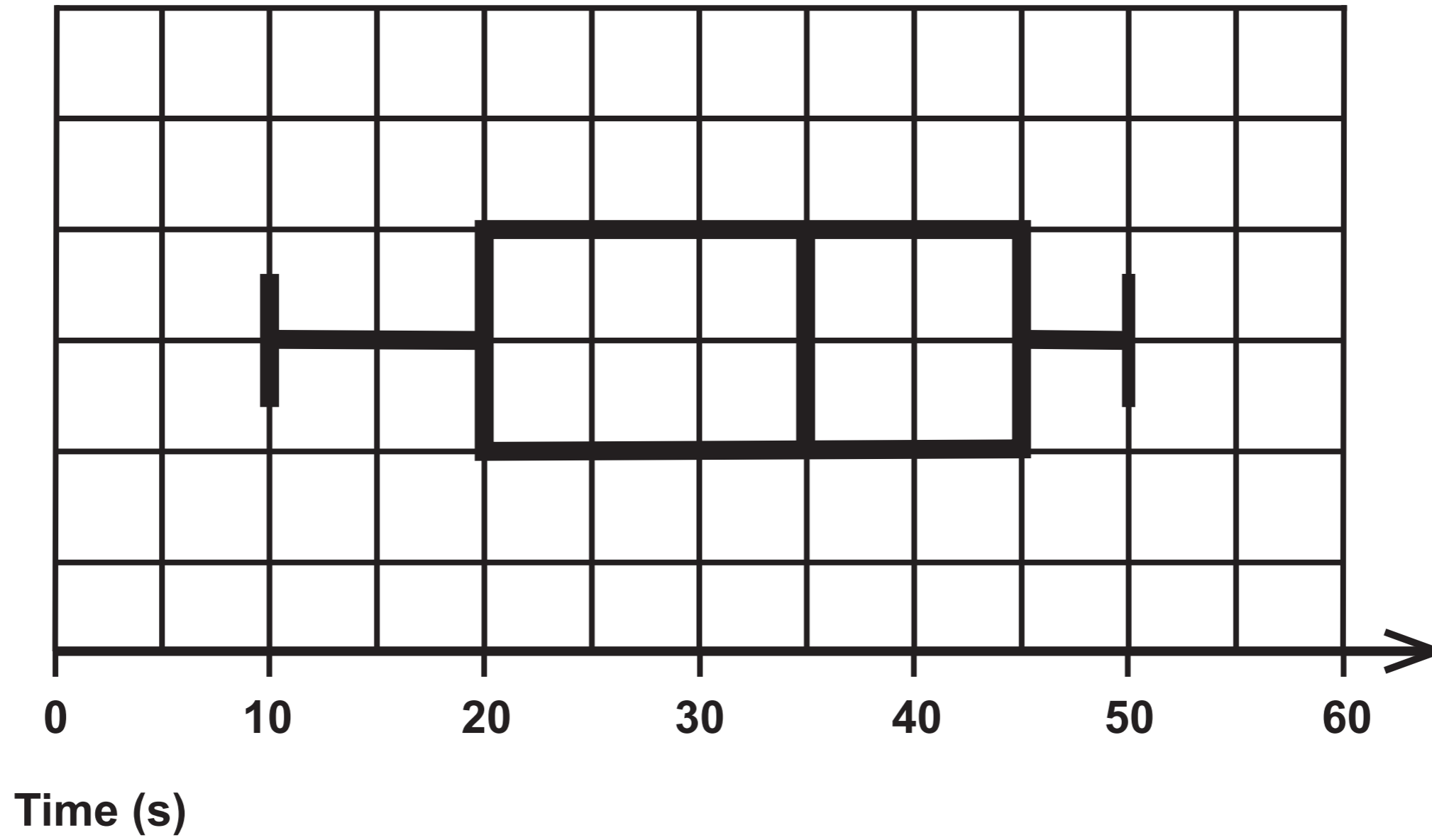

Question 5 (c)

Diagrams NOT drawn to scale

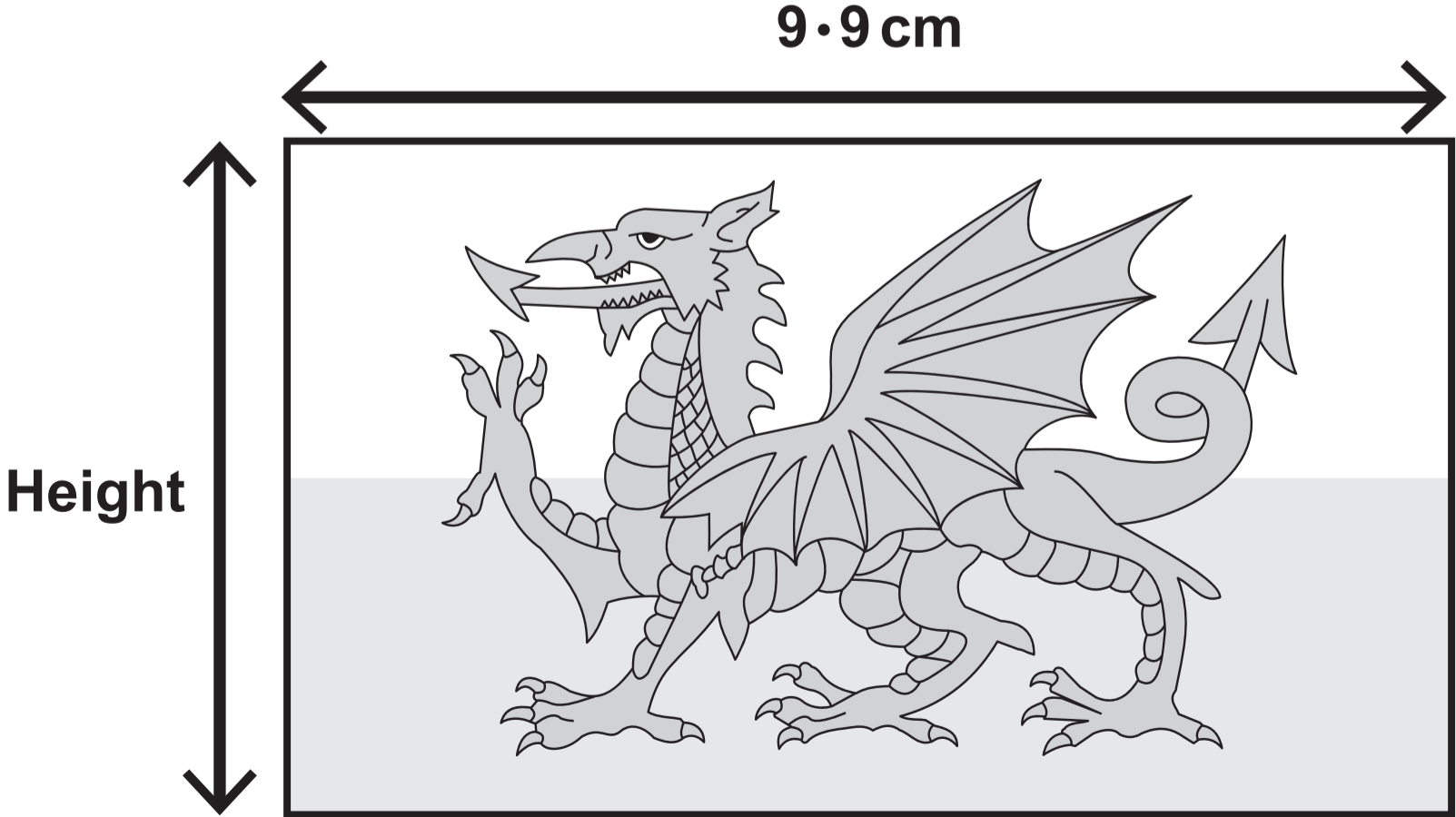
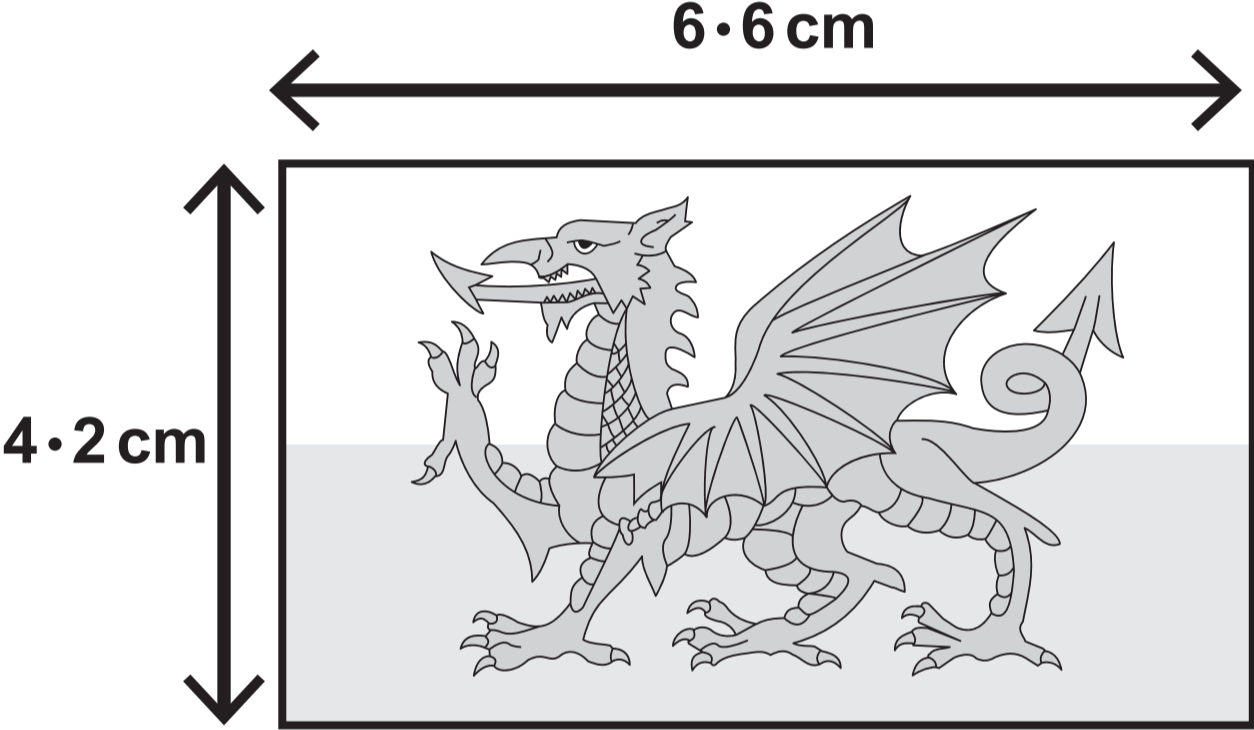
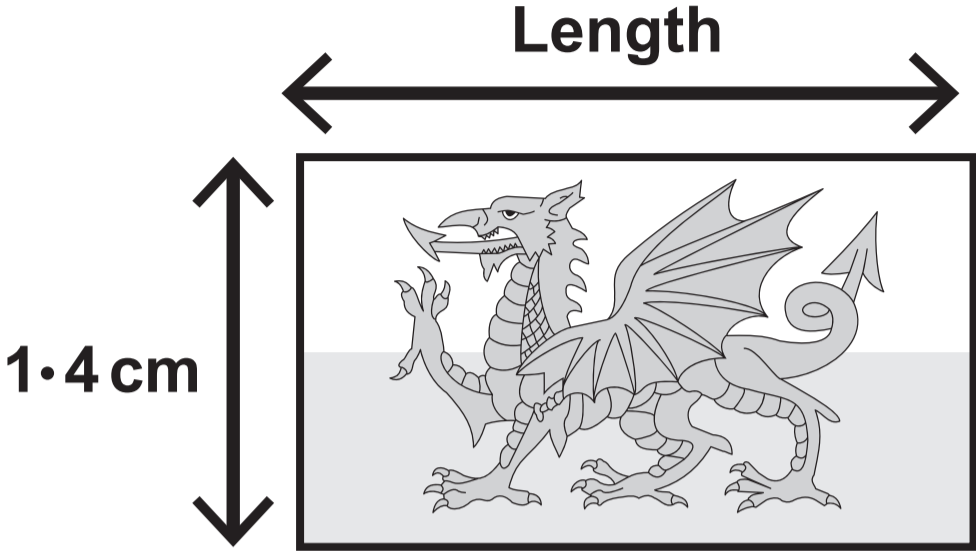

Question 7

Table

Time taken, t (minutes)	Frequency	Frequency density
$0 < t \leq 10$	30	3
$10 < t \leq 20$	40	
$20 < t \leq 35$	30	
$35 < t \leq 50$	15	
$50 < t \leq 70$	5	

Question 7 (a) (ii)

Frequency
density

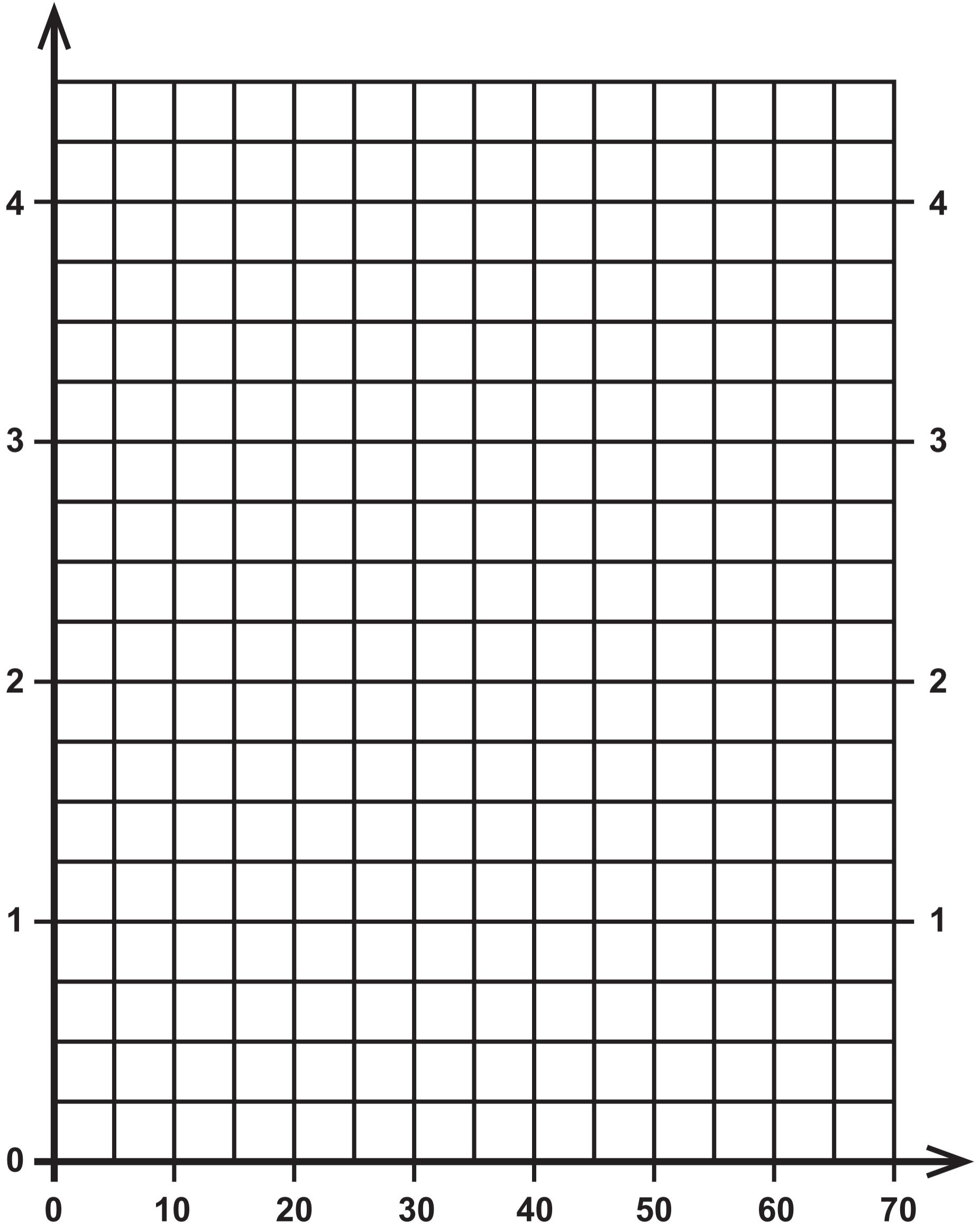

Time, t (minutes)

Question 8

Speed (m/s)

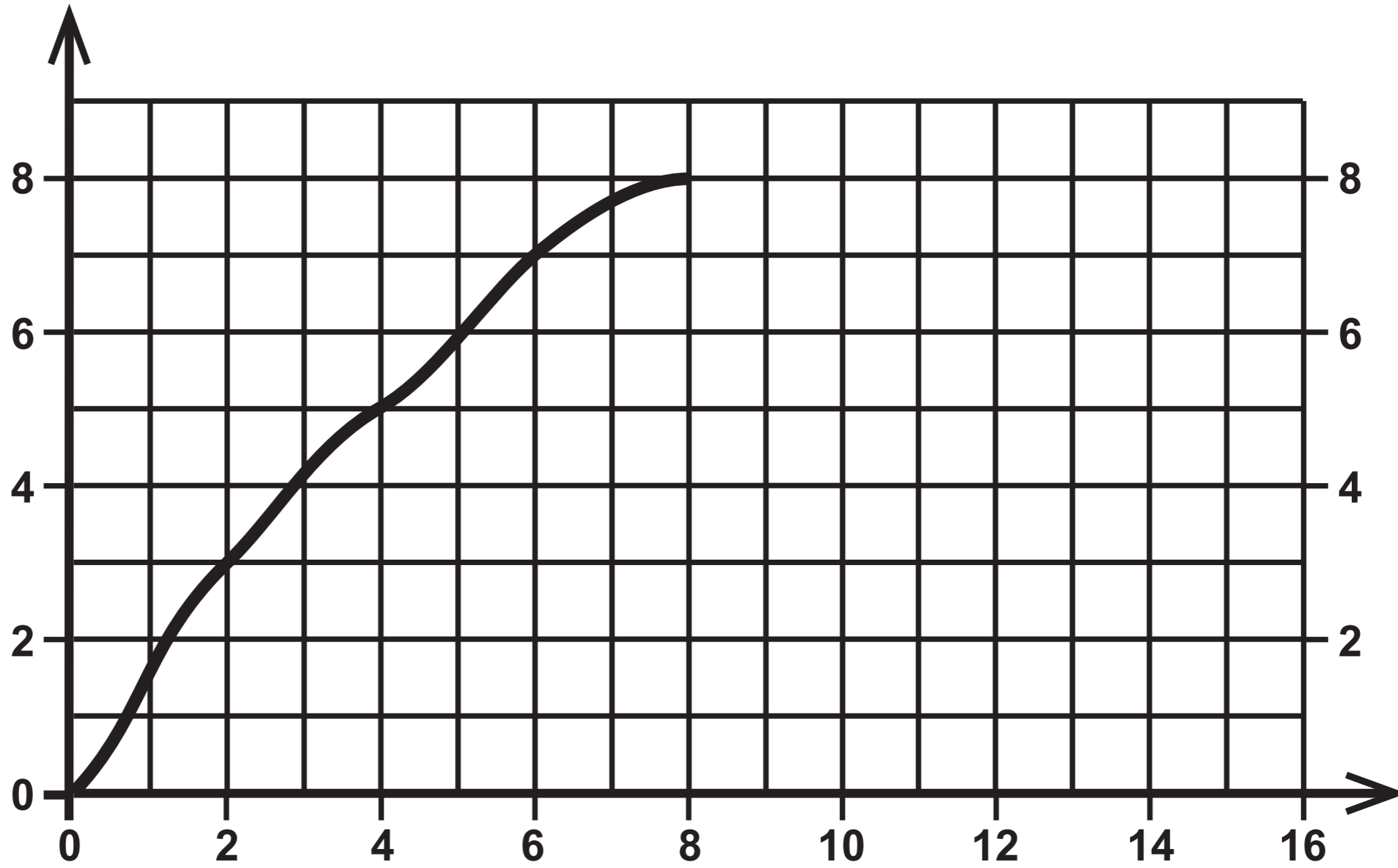

Time (seconds)

Question 9 (a)

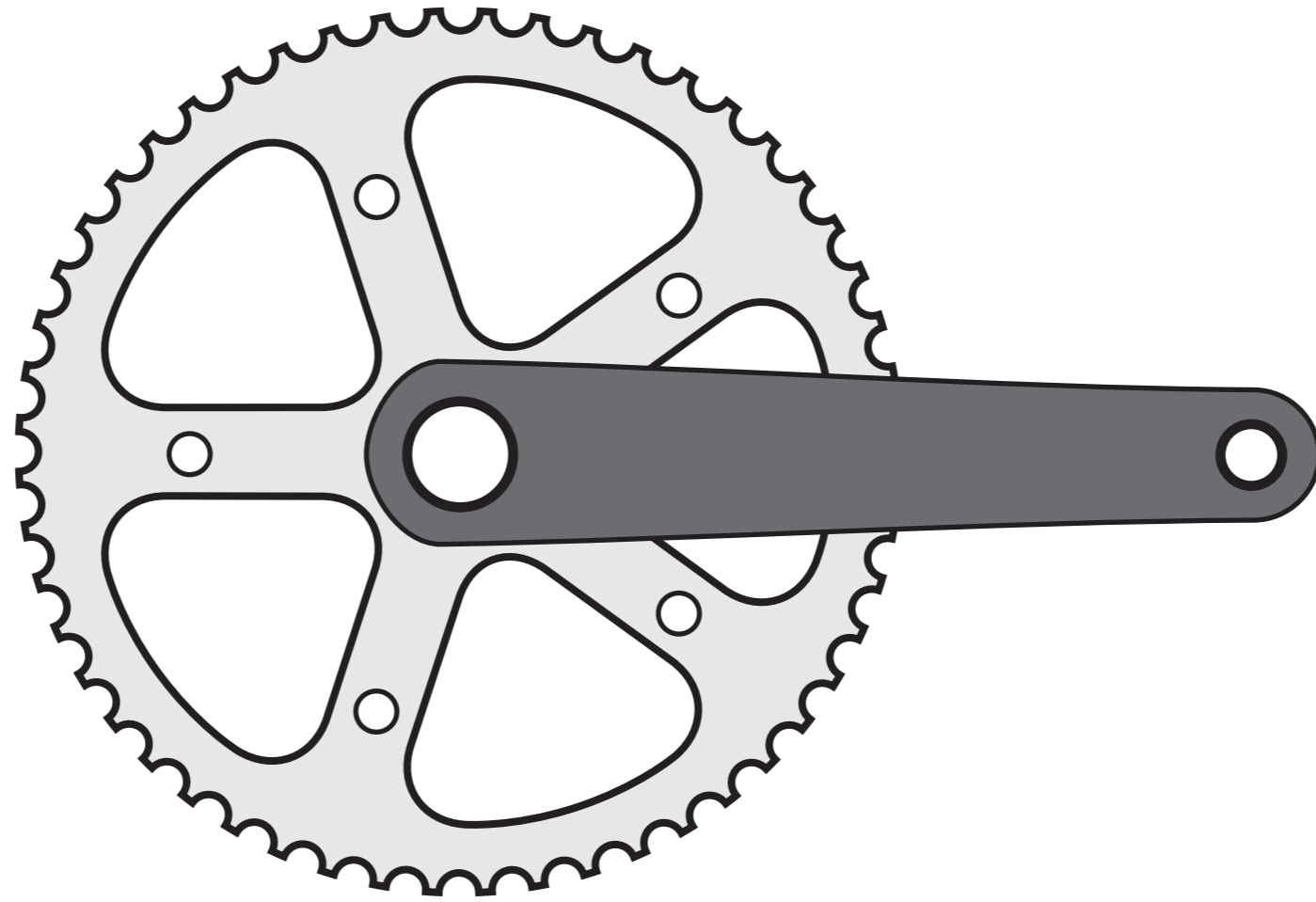

Question 9 (b)

Diagram NOT drawn to scale

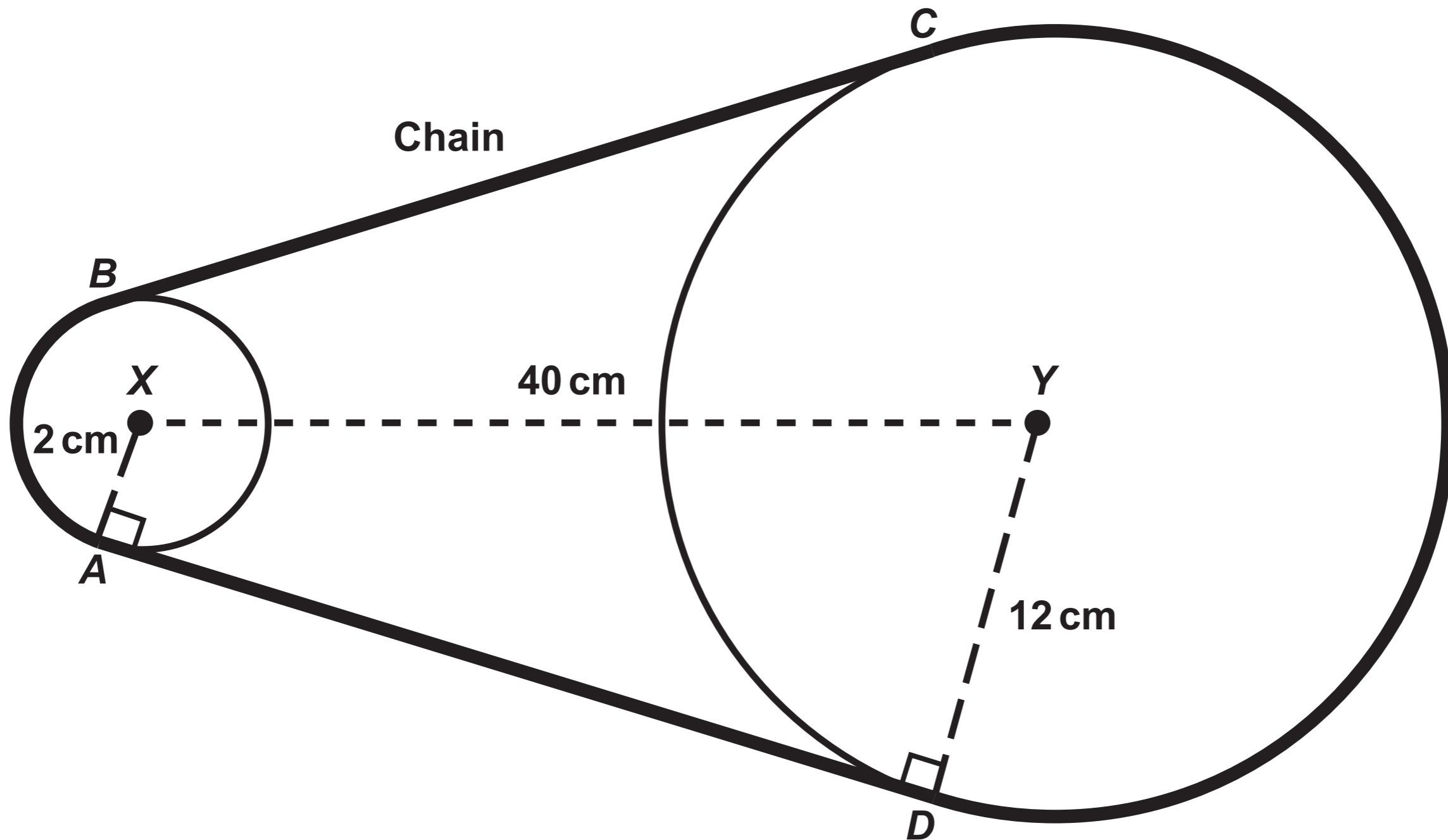

Question 9 (b) (ii)

Diagram NOT drawn to scale

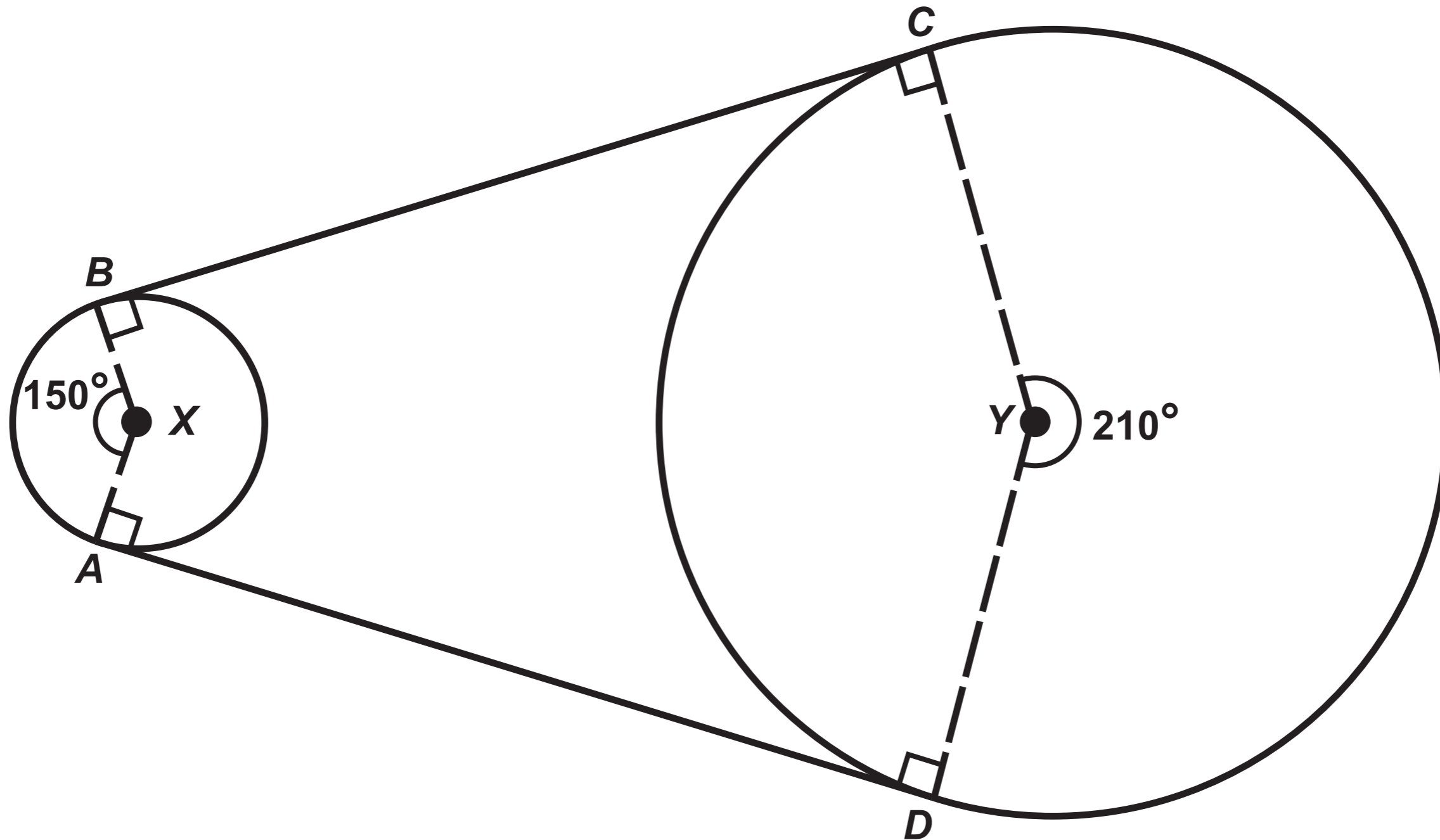

**GCSE
MATHEMATICS
and
NUMERACY**

**FORMULA LIST
HIGHER TIER
GCSE**

You must not write on these formula pages.

Anything you write on these formula pages will gain NO credit.

Formula List – Higher Tier

$$\text{Area of trapezium} = \frac{1}{2} (a + b) h$$

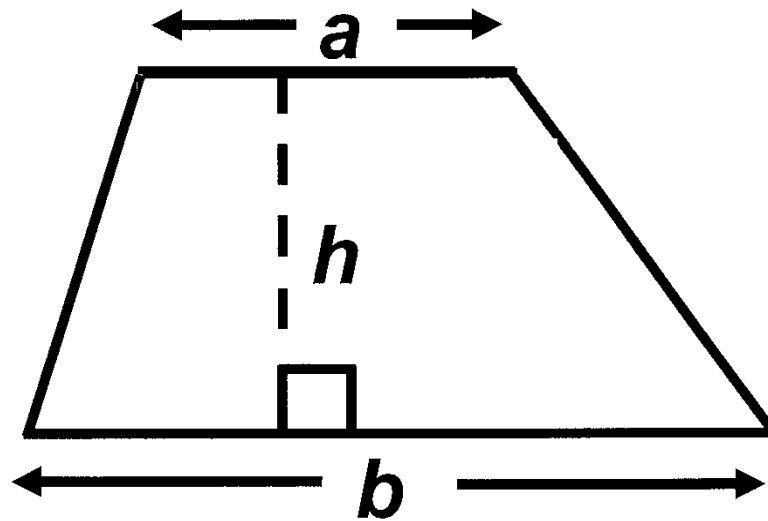

Volume of prism =
area of cross – section \times length

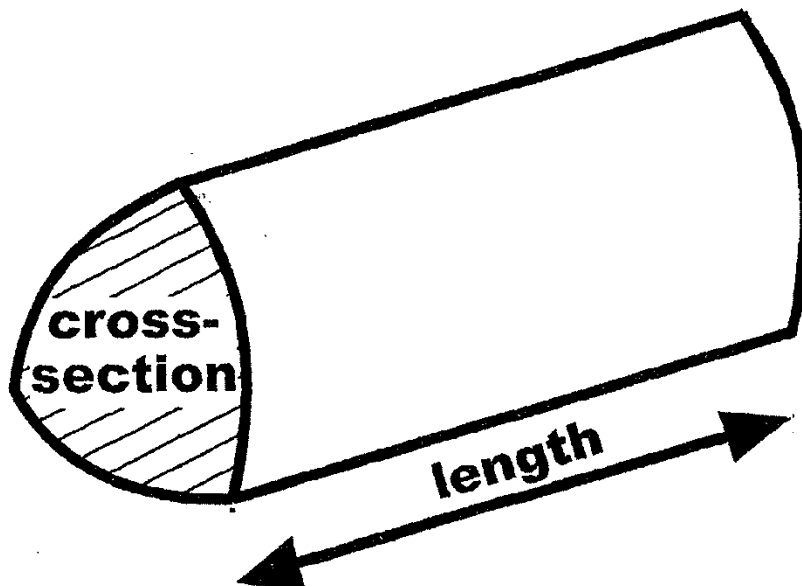

Volume of sphere = $\frac{4}{3}\pi r^3$

Surface area of sphere = $4\pi r^2$

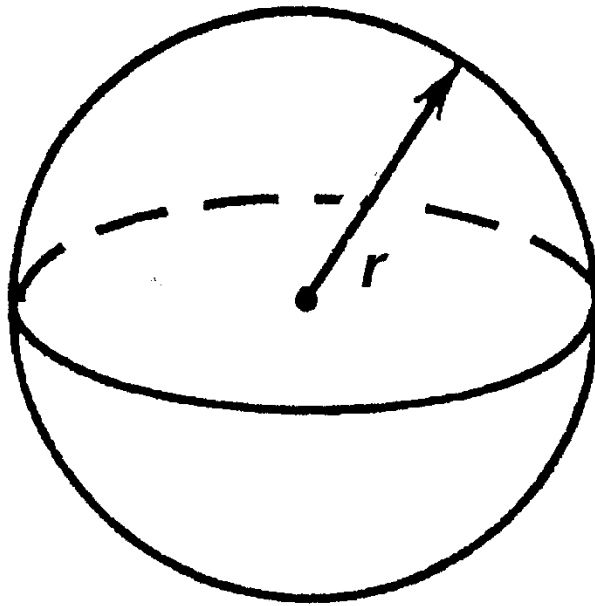

Volume of cone = $\frac{1}{3}\pi r^2 h$

Curved surface area of cone = $\pi r l$

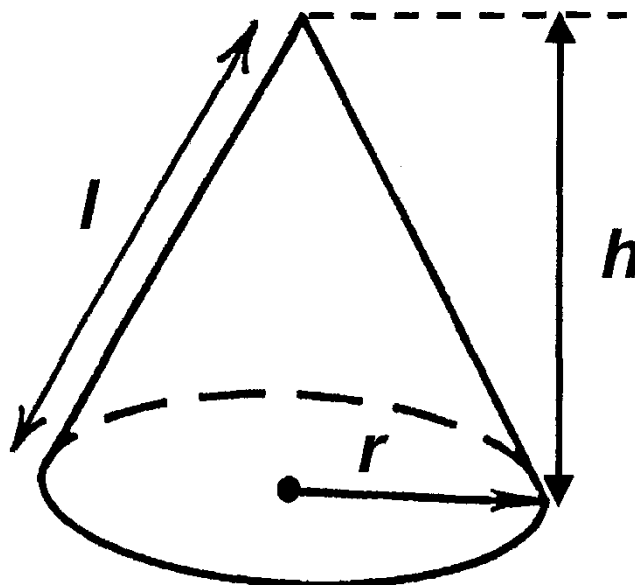

In any triangle ABC

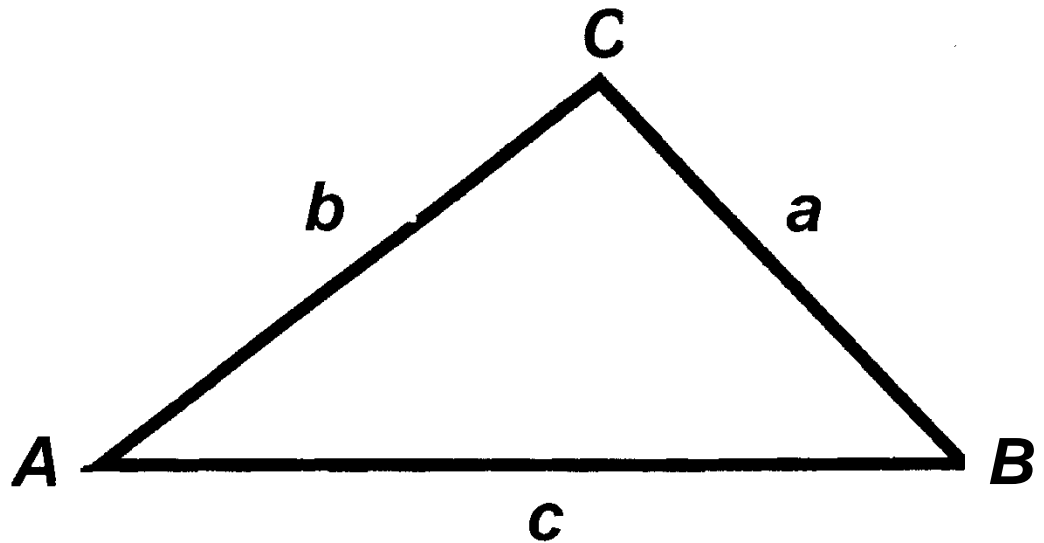

Sine Rule $\frac{a}{\sin A} = \frac{b}{\sin B} = \frac{c}{\sin C}$

Cosine Rule $a^2 = b^2 + c^2 - 2bc \cos A$

Area of triangle $= \frac{1}{2} ab \sin C$

The Quadratic Equation

The solutions of $ax^2 + bx + c = 0$

where $a \neq 0$, are given by

$$x = \frac{-b \pm \sqrt{b^2 - 4ac}}{2a}$$

Annual Equivalent Rate (AER)

AER, as a decimal, is calculated using the formula $\left(1 + \frac{i}{n}\right)^n - 1$, where i is the nominal interest rate per annum as a decimal and n is the number of compounding periods per annum.