

**MONDAY, 8 JANUARY –  
FRIDAY, 9 FEBRUARY 2024**

**PHYSICS – Unit 3 (3420U30)**

**PRACTICAL ASSESSMENT**

**INVESTIGATING THE MOTION OF A  
FALLING OBJECT**

**SECTION A**

**1 hour, plus your additional time allowance**

**Surname** \_\_\_\_\_

**First name(s)** \_\_\_\_\_

**Centre Number** \_\_\_\_\_

**Candidate Number**   0   \_\_\_\_\_



## **ADDITIONAL MATERIALS**

**A calculator.**

## **INSTRUCTIONS TO CANDIDATES**

**Use black ink, black ball-point pen or your usual method.**

**Write your name, centre number and candidate number in the spaces provided on the front cover.**

**Answer ALL questions.**

**Write your answers in the spaces provided in this booklet. If you run out of space, use the additional pages at the back of the booklet, taking care to number the question(s) correctly.**



**INFORMATION FOR CANDIDATES**

**The total number of marks available for this section of the task is 6.**

**The number of marks is given in brackets at the end of each question or part-question.**

**This task is in 2 sections, A and B. You will complete Section A in one lesson and Section B in the next science lesson.**

**(Turn over)**

<b>For Examiner's use only</b>		
	<b>Maximum Mark</b>	<b>Mark Awarded</b>
<b>Section A</b>	<b>6</b>	

## **Introduction**

**Your task is to investigate the effect of distance on the time taken for an object to fall.**

## **Apparatus Required**

**The following apparatus is required for each group: (each group should consist of no more than three candidates).**

**2 × metre ruler (attached) or 1 × tape measure**

**1 × clamp stand and pointer**

**1 × paper cake case**

**1 × stopwatch**

**READ THE METHOD AND ANSWER QUESTIONS 1.(a) AND 1.(b) BEFORE CARRYING OUT THE EXPERIMENT AND RECORDING YOUR RESULTS.**

**(Turn over)**



5

# Diagram

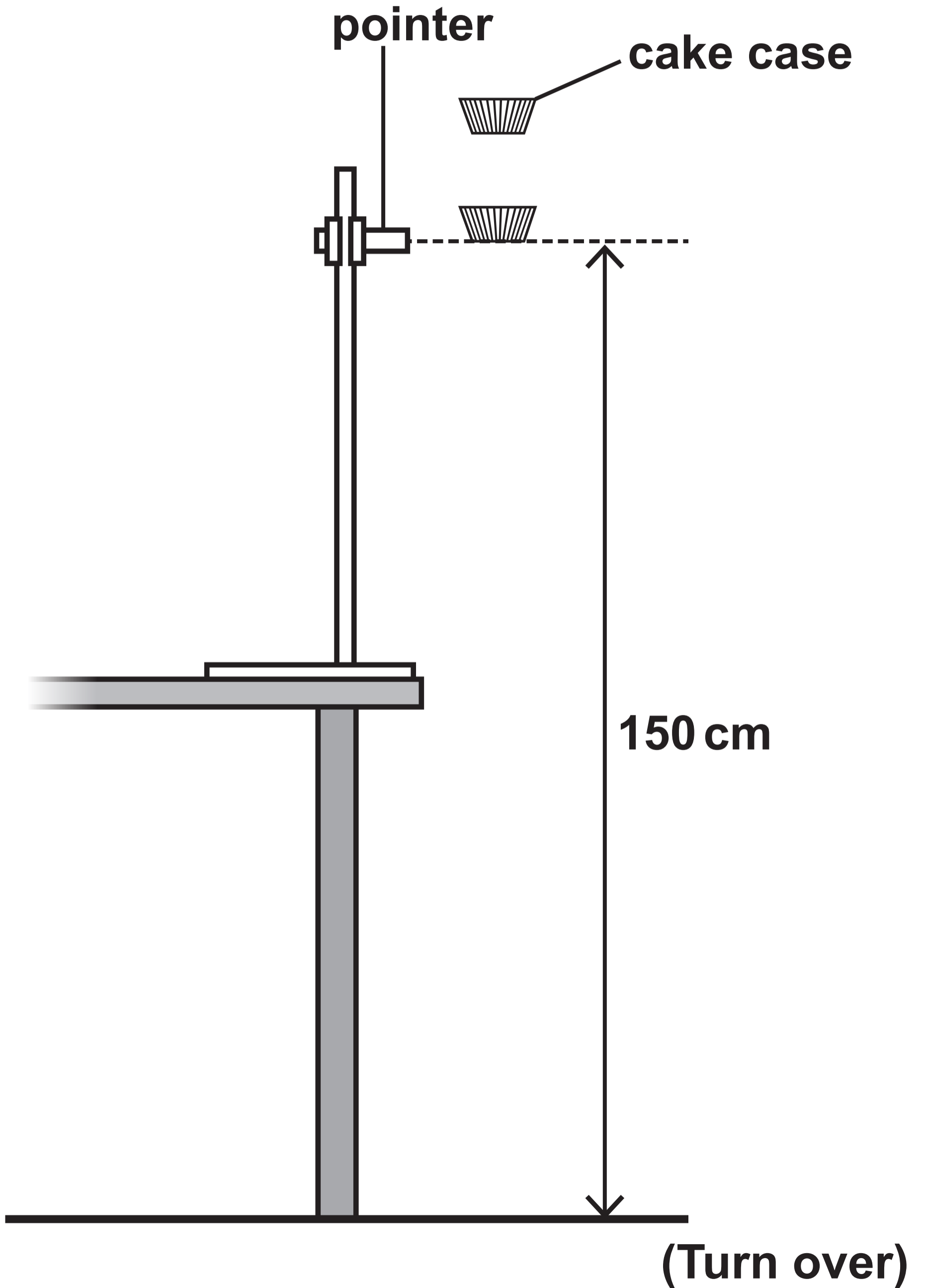



## **Method**

- 1. Use the metre rulers to set the height of the pointer in the clamp stand at 150 cm above the floor.**
- 2. Take a single cake case.**
- 3. Drop the cake case approximately 20 cm above the pointer.**
- 4. Start the stopwatch as the cake case passes the pointer and stop it when it lands on the floor.**
- 5. Record the time taken for it to fall the distance from the pointer to the floor.**
- 6. Repeat steps 3–5 two more times to get three results in total.**
- 7. Repeat steps 2–6 with the pointer set at heights of 130 cm, 110 cm, 90 cm, 70 cm and 50 cm above the floor.**

**(Turn over)**



# SECTION A

**Answer ALL questions.**

**1 (a) State a hypothesis for this experiment. [1 mark]**

---

---

---

---

**(Turn over)**



**THIS IS A BLANK PAGE**

**TURN OVER**

<b>HAZARD</b>	<b>RISK</b>	<b>CONTROL MEASURE</b>

**1 (b) Complete the risk assessment on the opposite page for this experiment.  
[1 mark]**

**YOU MAY RECORD RAW RESULTS  
IN THE SPACE BELOW.**

**(Turn over)**



**1 (c) Present your results in a table.  
Include all of your results. [4 marks]**

<b>6</b>

**END OF PAPER**



<b>Question number</b>	<b>Additional page, if required. Write the question numbers in the left-hand margin.</b>



<b>Question number</b>	<b>Additional page, if required. Write the question numbers in the left-hand margin.</b>



<b>Question number</b>	<b>Additional page, if required. Write the question numbers in the left-hand margin.</b>



<b>Question number</b>	<b>Additional page, if required. Write the question numbers in the left-hand margin.</b>



<b>Question number</b>	<b>Additional page, if required. Write the question numbers in the left-hand margin.</b>