



GCSE



C490UA0-1

FRIDAY, 10 MAY 2024 – AFTERNOON

ELECTRONICS – Component 1

Discovering Electronics

1 hour 30 minutes plus your additional time allowance

Surname _____

First name(s) _____

Centre Number _____

Candidate Number 0 _____

For Examiner's use only

Question	Maximum Mark	Mark Awarded
1.	6	
2.	10	
3.	16	
4.	12	
5.	12	
6.	5	
7.	13	
8.	6	
Total	80	

ADDITIONAL MATERIALS

A calculator and a ruler.

INSTRUCTIONS TO CANDIDATES

Use black ink, black ball-point pen or your usual method.

You may use a pencil for graphs and diagrams only.

Write your name, centre number and candidate number in the spaces provided on the front cover.

Answer ALL questions.

Write your answers in the spaces provided in this booklet. If you run out of space, use the additional page(s) at the back of the booklet, taking care to number the question(s) correctly.

INFORMATION FOR CANDIDATES

The number of marks is given in brackets at the end of each question or part-question.

The assessment of the quality of extended response (QER) will take place in question 8.

(Turn over)

USEFUL EQUATIONS

$$P = \frac{V^2}{R}$$

$$G = 1 + \frac{R_F}{R_1}$$

$$V_{OUT} = \frac{R_2}{R_1 + R_2} V_{IN}$$

$$G = -\frac{R_F}{R_{IN}}$$

$$I_D = g_M(V_{GS} - 3)$$

$$V_{OUT} = -R_F \left(\frac{V_1}{R_1} + \frac{V_2}{R_2} + \dots \right)$$

$$I_C = h_{FE} I_B$$

$$T = 1.1RC$$

$$\overline{A + B} = \overline{A} \cdot \overline{B}$$

$$f = \frac{1}{T}$$

$$\overline{A \cdot B} = \overline{A} + \overline{B}$$

$$f = \frac{1.44}{(R_1 + 2R_2)C}$$

$$G = \frac{V_{OUT}}{V_{IN}}$$

$$\frac{T_{ON}}{T_{OFF}} = \frac{R_1 + R_2}{R_2}$$

INFORMATION SHEET

This information may be of use in answering the questions.

RESISTOR COLOUR CODES

Black	0	Green	5
Brown	1	Blue	6
Red	2	Violet	7
Orange	3	Grey	8
Yellow	4	White	9

The fourth band colour gives the tolerance as follows:

GOLD \pm 5%

SILVER \pm 10%

RESISTORS E24 SERIES VALUES

10, 11, 12, 13, 15, 16, 18, 20, 22, 24, 27, 30,
33, 36, 39, 43, 47, 51, 56, 62, 68, 75, 82, 91

USEFUL EQUATIONS (shown opposite)

(Turn over)

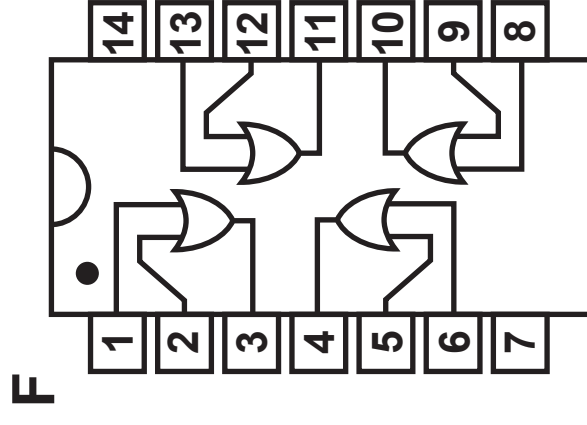
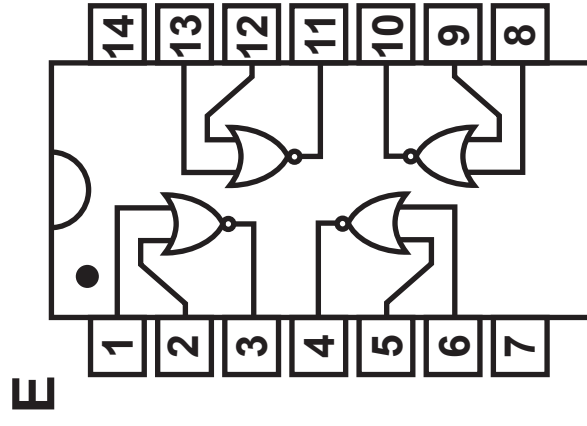
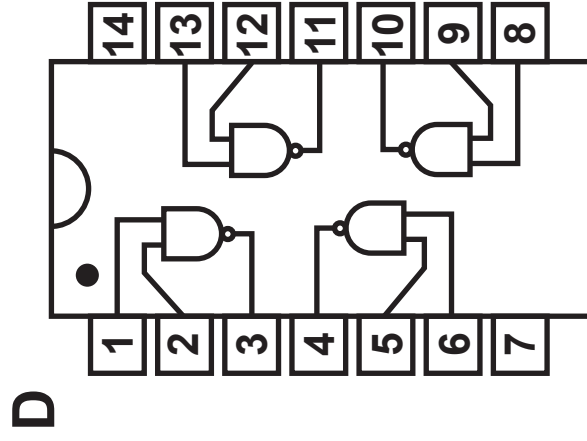
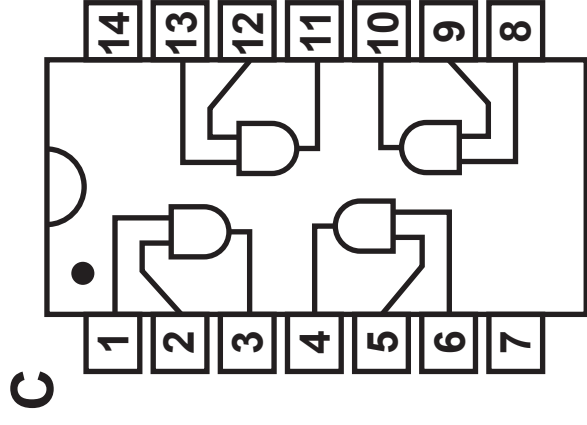
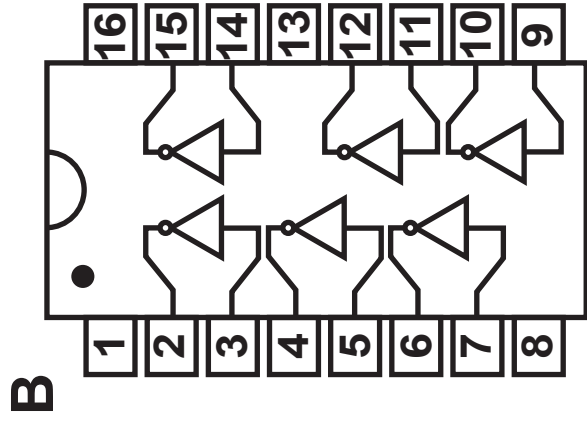
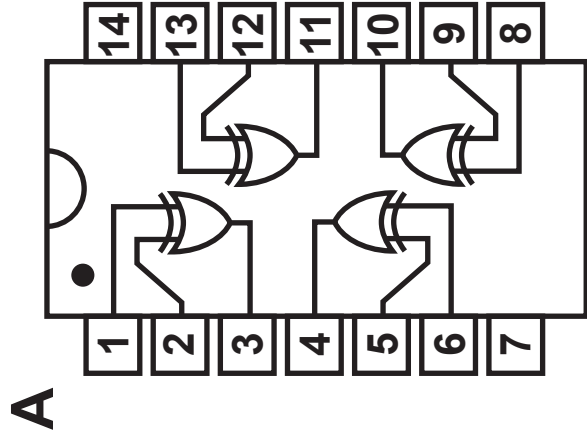

Answer ALL questions.

1. The diagram opposite shows the pinout diagrams for some ICs (integrated circuits).

(a) Which IC (A to F) contains the following logic gates?

(i) NOT gates _____

(ii) NOR gates _____

[2 marks]

(Turn over)

1 (b) (i)

Which IC (A to F) contains logic gates with the following truth table? [1 mark]

B	A	Q
0	0	0
0	1	1
1	0	1
1	1	1

Answer: _____

(ii) Which IC (A to F) contains logic gates with the following truth table? [1 mark]

B	A	Q
0	0	0
0	1	0
1	0	0
1	1	1

Answer: _____

(Turn over)

1 (c) Complete the following truth tables for:

(i) a logic gate in **D**; [1 mark]

B	A	Q
0	0	
0	1	
1	0	
1	1	

(ii) a logic gate in **E**. [1 mark]

B	A	Q
0	0	
0	1	
1	0	
1	1	

Input sub-systems	Processing sub-systems	Output sub-systems

2. (a) A number of electronic sub-systems are listed below.

AND GATE

TRANSDUCER DRIVER

LAMP UNIT

MOISTURE SENSING UNIT

LATCH UNIT

MOTOR UNIT

LIGHT SENSING UNIT

PRESSURE SENSING UNIT

NOR GATE

Write each sub-system into the correct column in the table opposite. [3 marks]

2 (b) A tropical fish tank needs controlled conditions to keep plants and fish healthy.



SPECIFICATION

- **The water is maintained at a constant temperature by a high-power heater.**
- **It must be possible to switch off the heater so that maintenance can be carried out.**
- **To stimulate plant growth, the LED lights in the tank cover switch on during daylight hours but must turn off at night.**
- **During daylight hours only, a low-power motor drives a pump which circulates water through a filter to keep the water clear.**

(Turn over)

The following sub-systems are available.

OR GATE

TEMPERATURE SENSING UNIT

LIGHT SENSING UNIT

MOTOR UNIT

INPUT VOLTAGE UNIT

LATCH UNIT

PULSE GENERATOR

SWITCH UNIT

MOSFET

TRANSISTOR SWITCH UNIT

AND GATE

NOT GATE

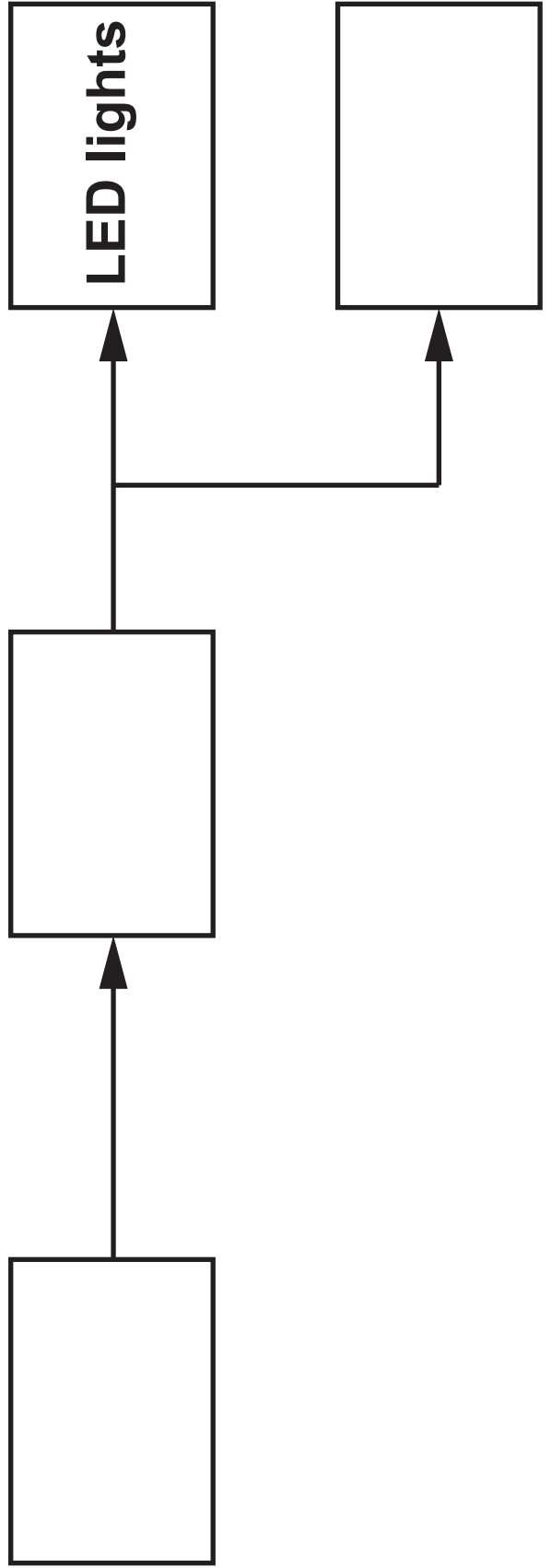
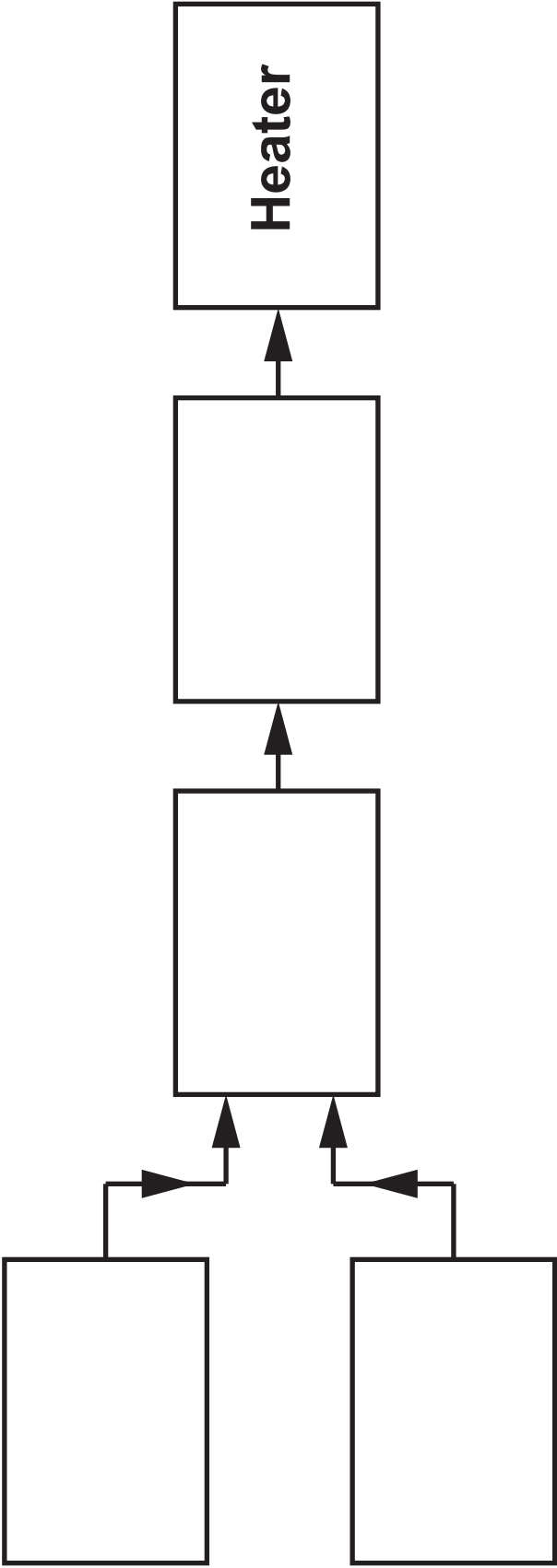

The sensing units behave as follows:

- The input voltage unit can be set to produce a voltage anywhere between zero and the maximum voltage.
- The light sensing unit outputs a low voltage in the dark.
- The temperature sensing unit provides a decreasing output voltage as the temperature rises.

Select the correct sub-systems to complete the block diagrams opposite. [7 marks]

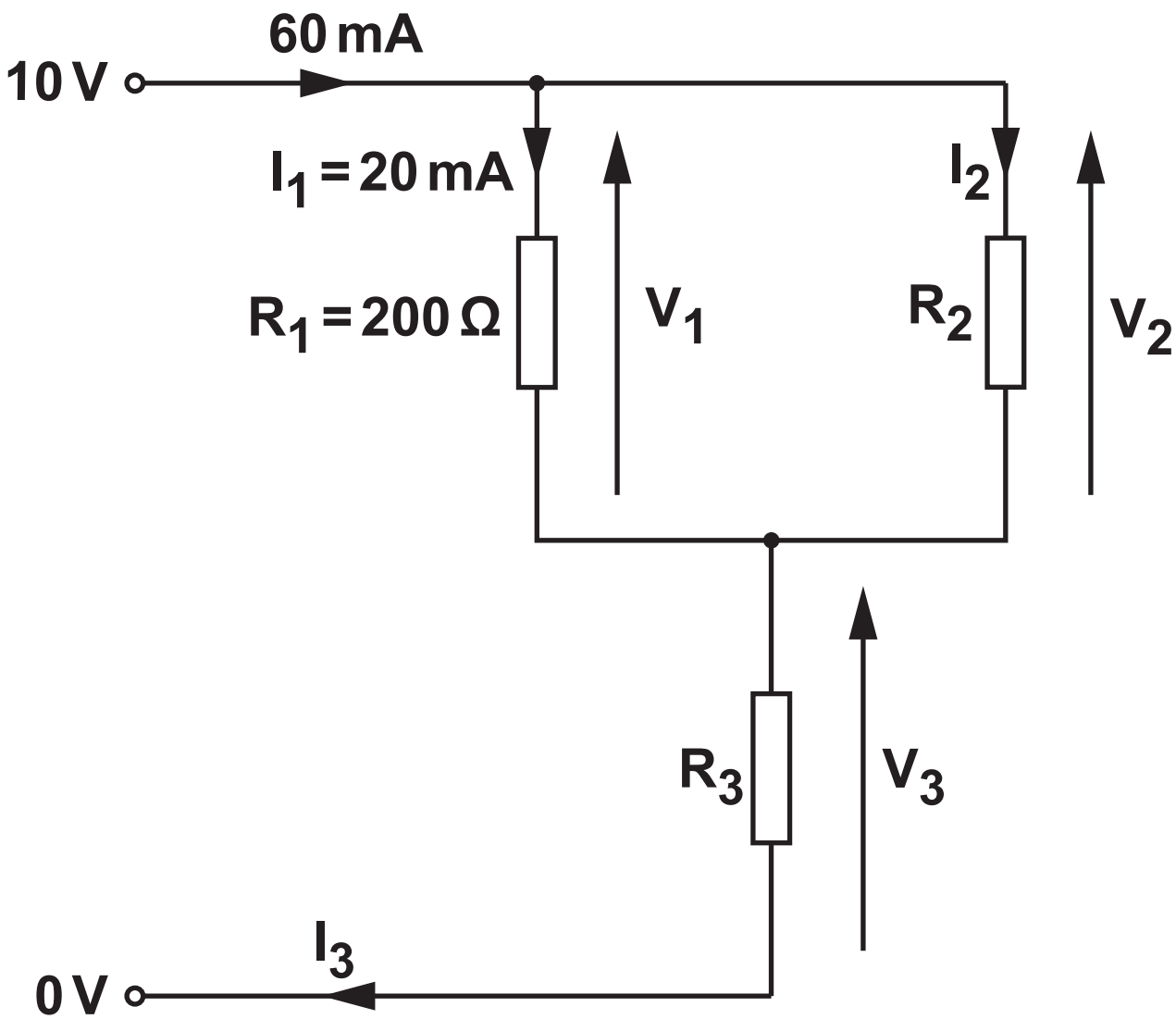

3. The diagram opposite shows part of a circuit.

(a) (i) What is the colour code on resistor R_1 ?

The tolerance band colour has been completed.

[3 marks]

Silver

(ii) Calculate the power dissipated in resistor R_1 .

[3 marks]

(b) (i) Determine the values of the following: [2 marks]

$$I_2 = \underline{\hspace{10em}}$$

$$I_3 = \underline{\hspace{10em}}$$

(Turn over)

3 (b) (ii)

Calculate the value of V_1 . [3 marks]

(iii) Determine the values of the following: [2 marks]

$V_2 =$ _____

$V_3 =$ _____

(iv) Calculate the value of R_2 . [3 marks]

4. (a) Look at the suggested truth table for a NOR gate connected as shown.

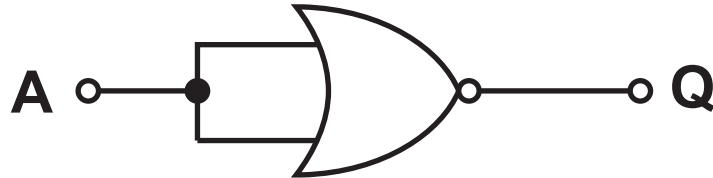

Inputs		Output
A	A	Q
0	0	1
0	1	0
1	0	0
1	1	0

- (i) **DRAW LINES** through the two rows of the truth table that cannot occur. [1 mark]
- (ii) What single logic gate does this NOR gate system behave as? [1 mark]
-

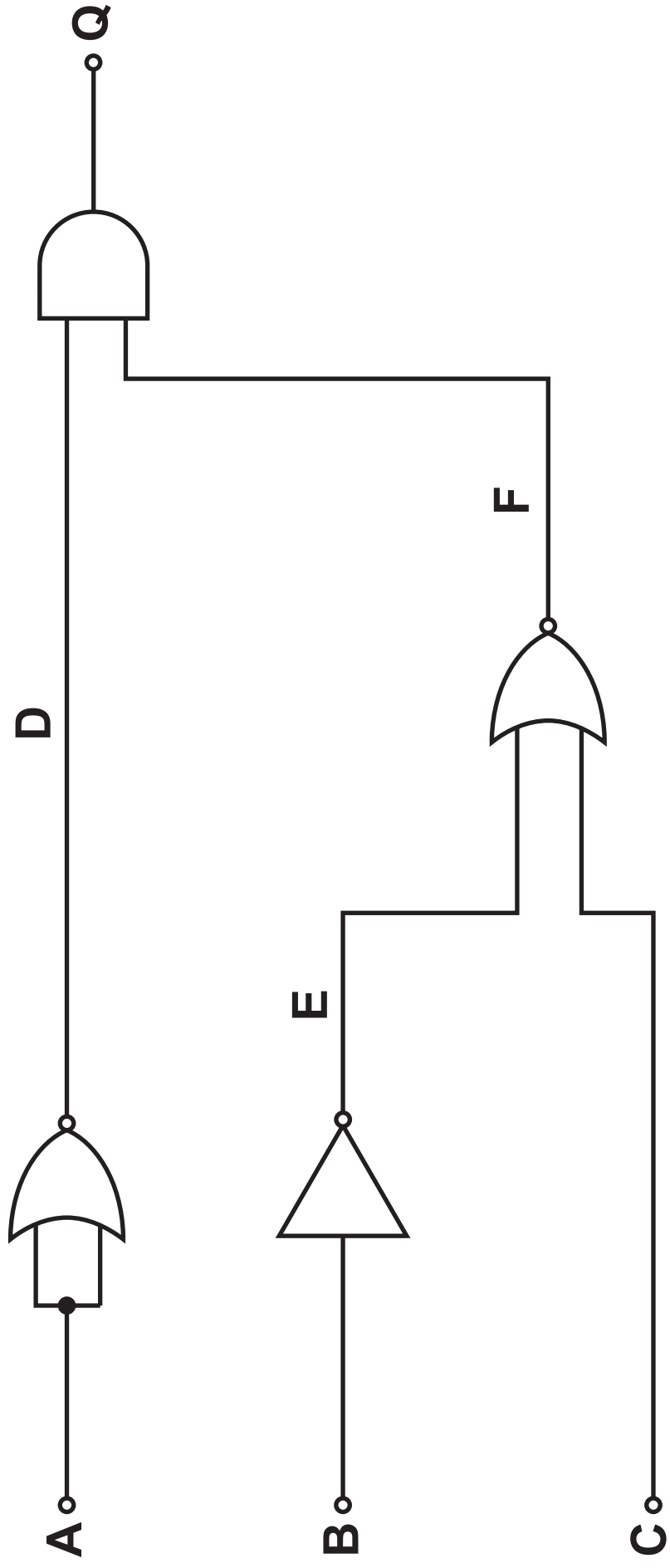

4 (b) A logic system is shown opposite:

Complete the following truth table for the logic system. [4 marks]

C	B	A	D	E	F	Q
0	0	0				
0	0	1				
0	1	0				
0	1	1				
1	0	0				
1	0	1				
1	1	0				
1	1	1				

(Turn over)

4 (c) (i)

REDRAW this logic circuit using NAND gates only.
[4 marks]

4 (c) (ii)

CROSS OUT all redundant NAND gates. [1 mark]

(iii) State an advantage of converting a logic system to NAND gates only. [1 mark]

5. A cricket umpire uses a light meter which shows when the light level is too low for play to continue safely. An incomplete circuit diagram for this is shown on the insert opposite.

(a) Which of the graphs opposite, A, B, C or D best shows the way in which the resistance of the LDR changes as the light level increases? [1 mark]

(b) What happens to the voltage V_1 as the resistance of the LDR increases? [1 mark]

5 (c) The output V_2 of the comparator saturates at 8.4V and 0V.

Complete the table to show:

- The output V_2 for the given values of the input voltages.
- If the LED is ON or OFF.

[2 marks]

Input 1 (V)	Input 2 (V)	Output V_2 (V)	LED
5.1	7.3		
7.5	7.1		

(d) COMPLETE THE CIRCUIT DIAGRAM on the insert opposite page 17 by adding:

- a voltage divider to provide a variable reference voltage for the comparator;
- any other connections so that the LED lights when the light level is too low for play.

[4 marks]

(Turn over)

5 (e) When the LED is on, the current through it is 12.5 mA and the forward voltage drop across it is 2.2 V.

(i) What is the voltage drop across resistor R when $V_2 = 8.4\text{ V}$? [1 mark]

(ii) What is the current flowing through resistor R when $V_2 = 8.4\text{ V}$? [1 mark]

(iii) Calculate the ideal resistance for resistor R. [2 marks]

6. The diagram below shows a D-type flip-flop being used for data transfer. The D-type is rising-edge triggered.

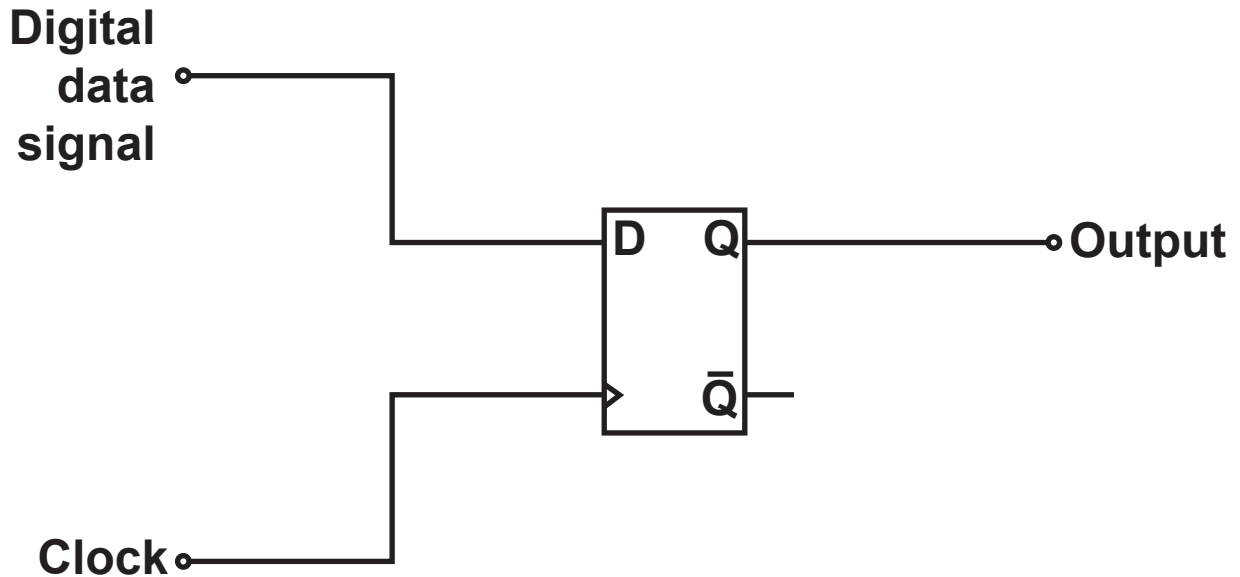

- (a) The digital data and clock signals are shown on the insert opposite. **COMPLETE THE OUTPUT GRAPH.** The output is initially low. [2 marks]

6 (b) The diagram below shows two D-type flip-flops connected as a 2-bit counter.

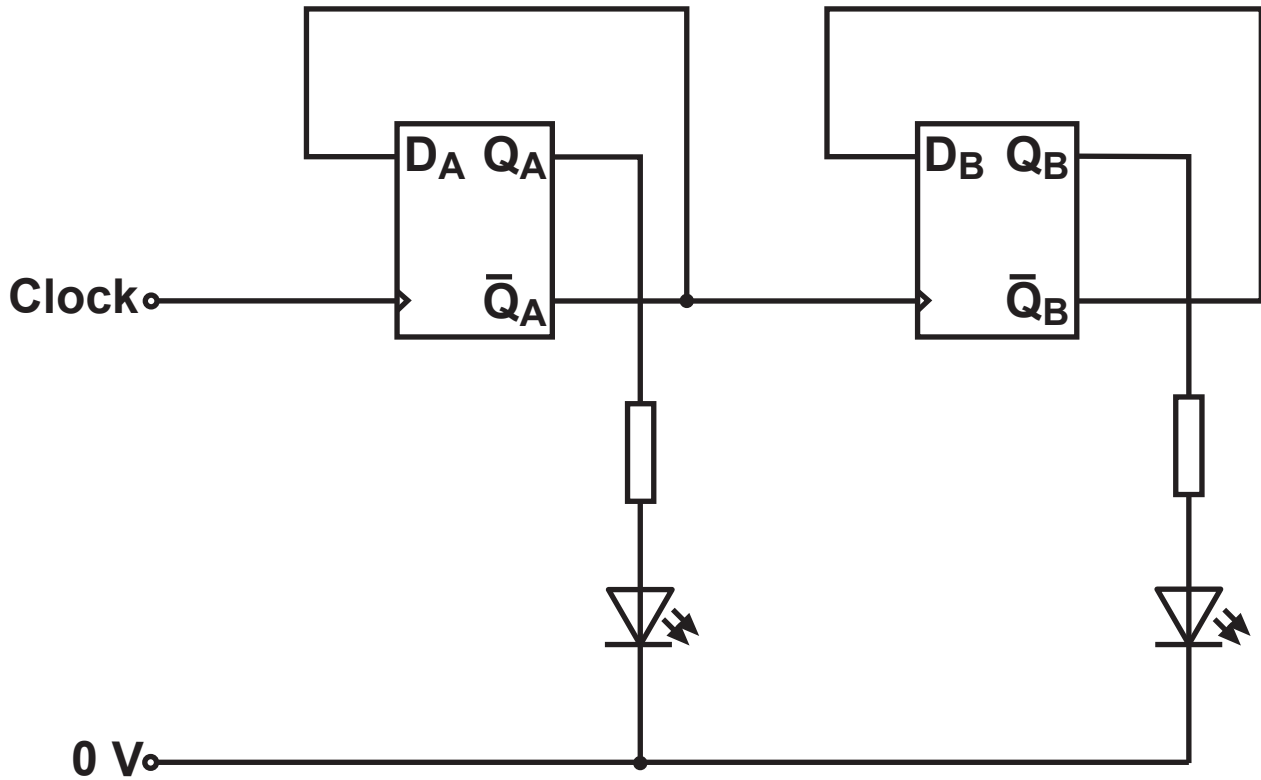

Complete the graphs on the insert opposite for Q_A and Q_B . Both outputs are initially at logic 0.

[3 marks]

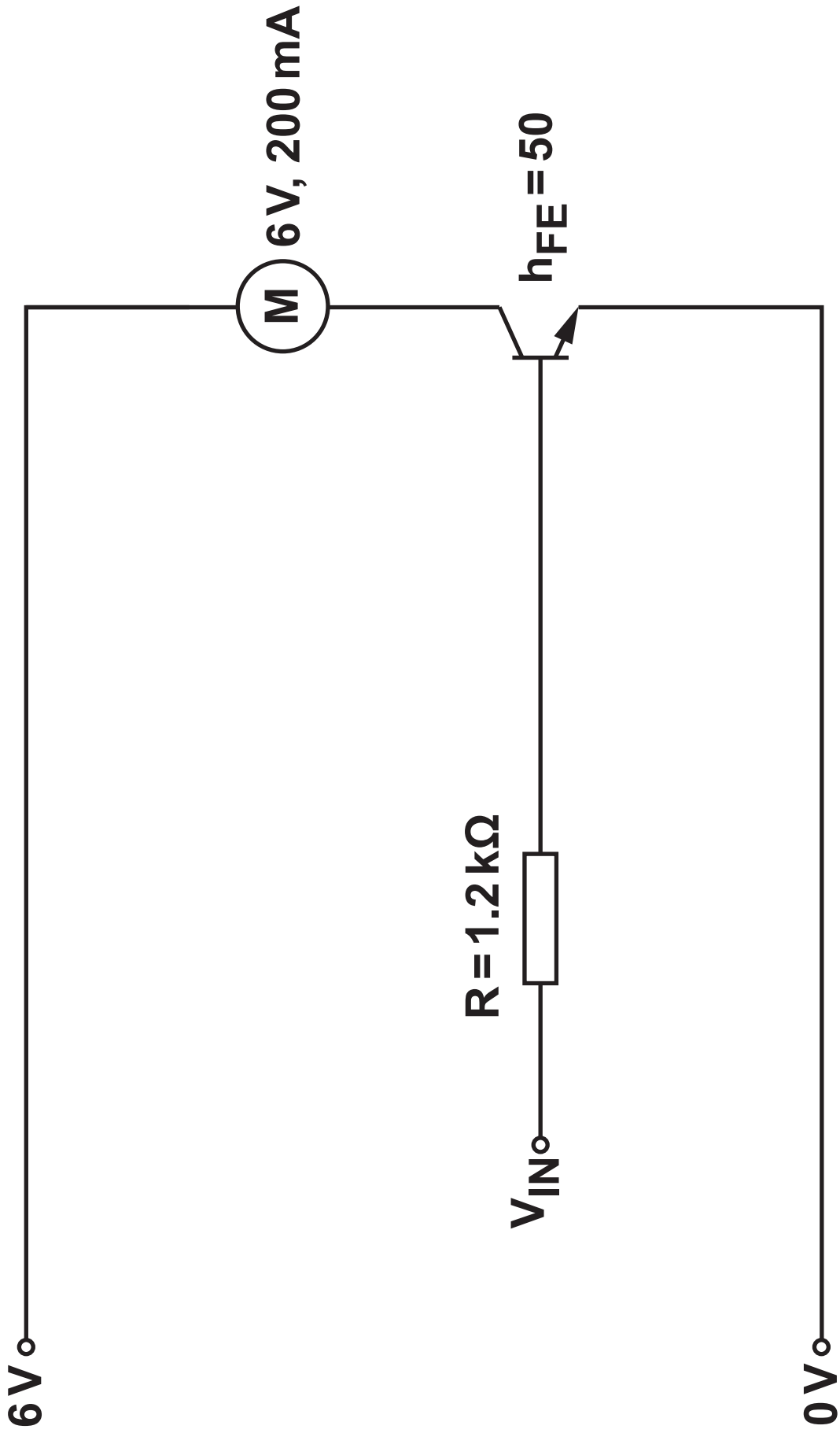

7. A transistor switching circuit that drives a small motor is shown opposite.

The transistor is just saturated.

(a) Calculate the base current flowing through the $1.2\text{ k}\Omega$ resistor. [4 marks]

(b) Calculate the voltage across the $1.2\text{ k}\Omega$ resistor. [2 marks]

7 (c) Calculate the value of V_{IN} . [2 marks]

(d) Calculate the power dissipated in the motor. [3 marks]

(e) **ADD A COMPONENT TO THE CIRCUIT DIAGRAM** opposite page 22 to protect the transistor from damage when the transistor switches off. [2 marks]

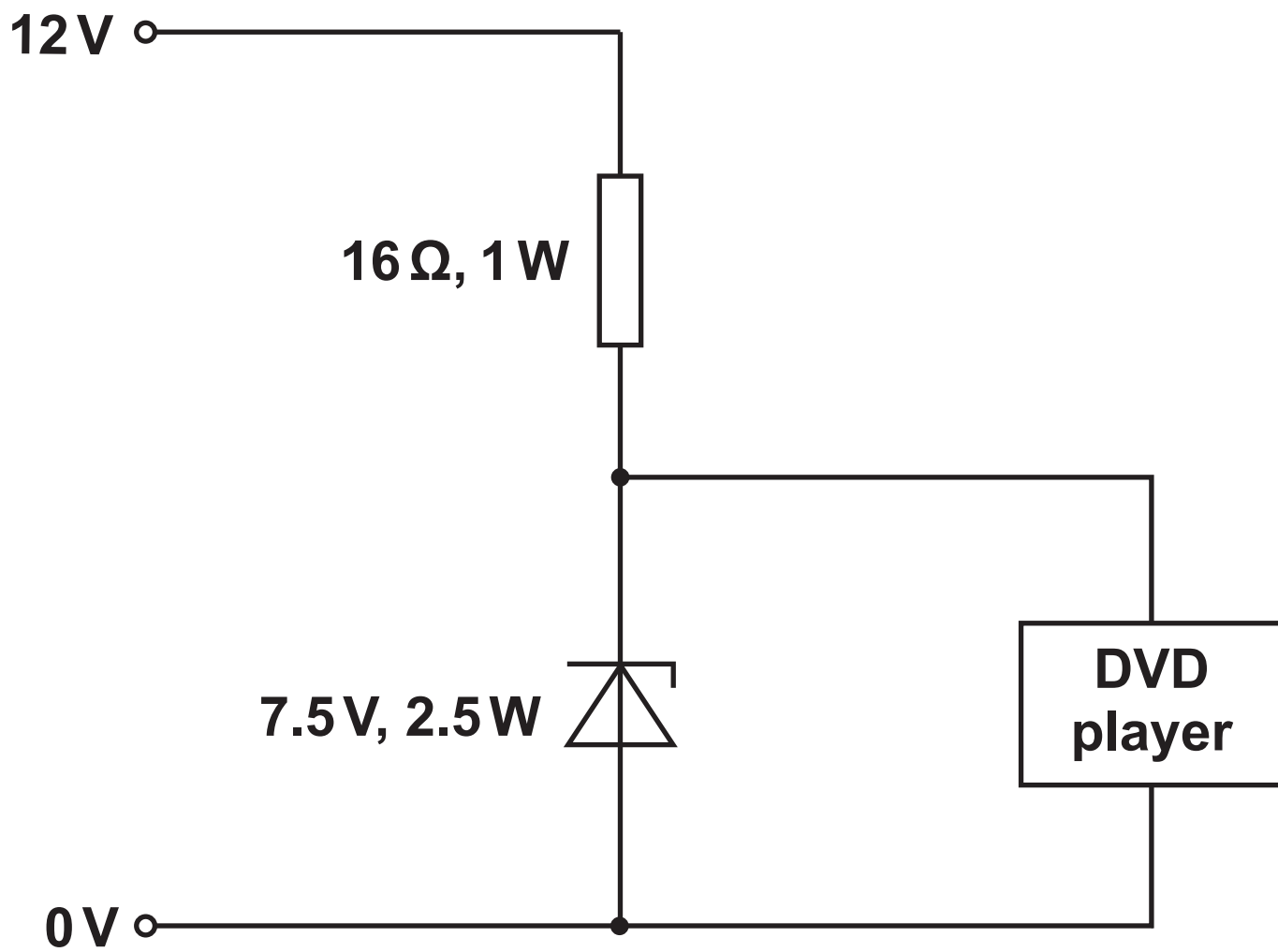

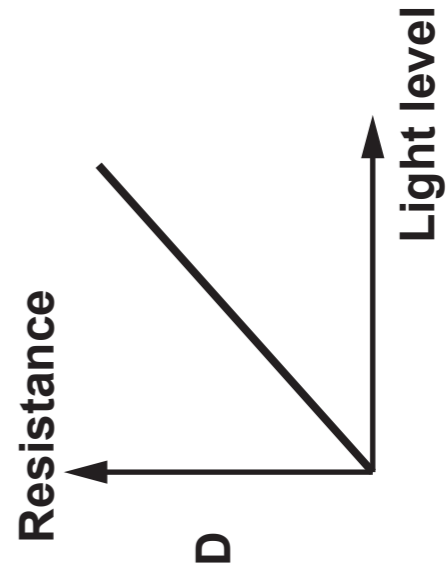
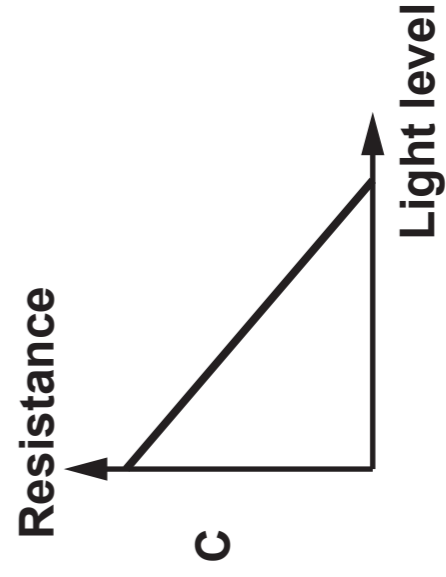
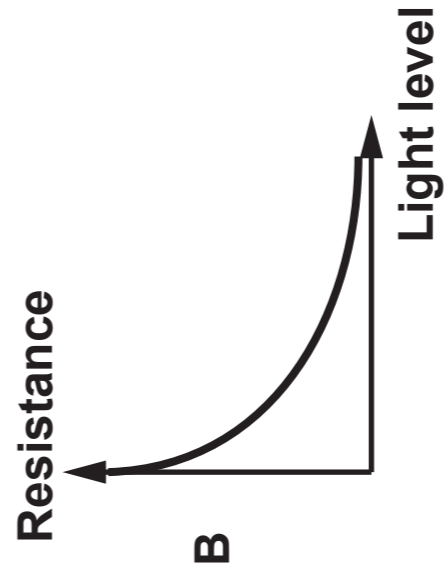
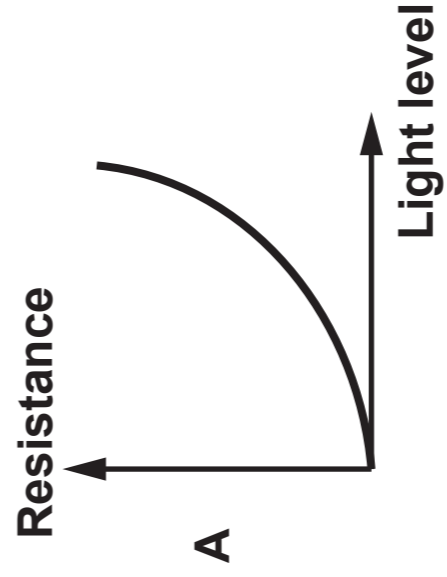
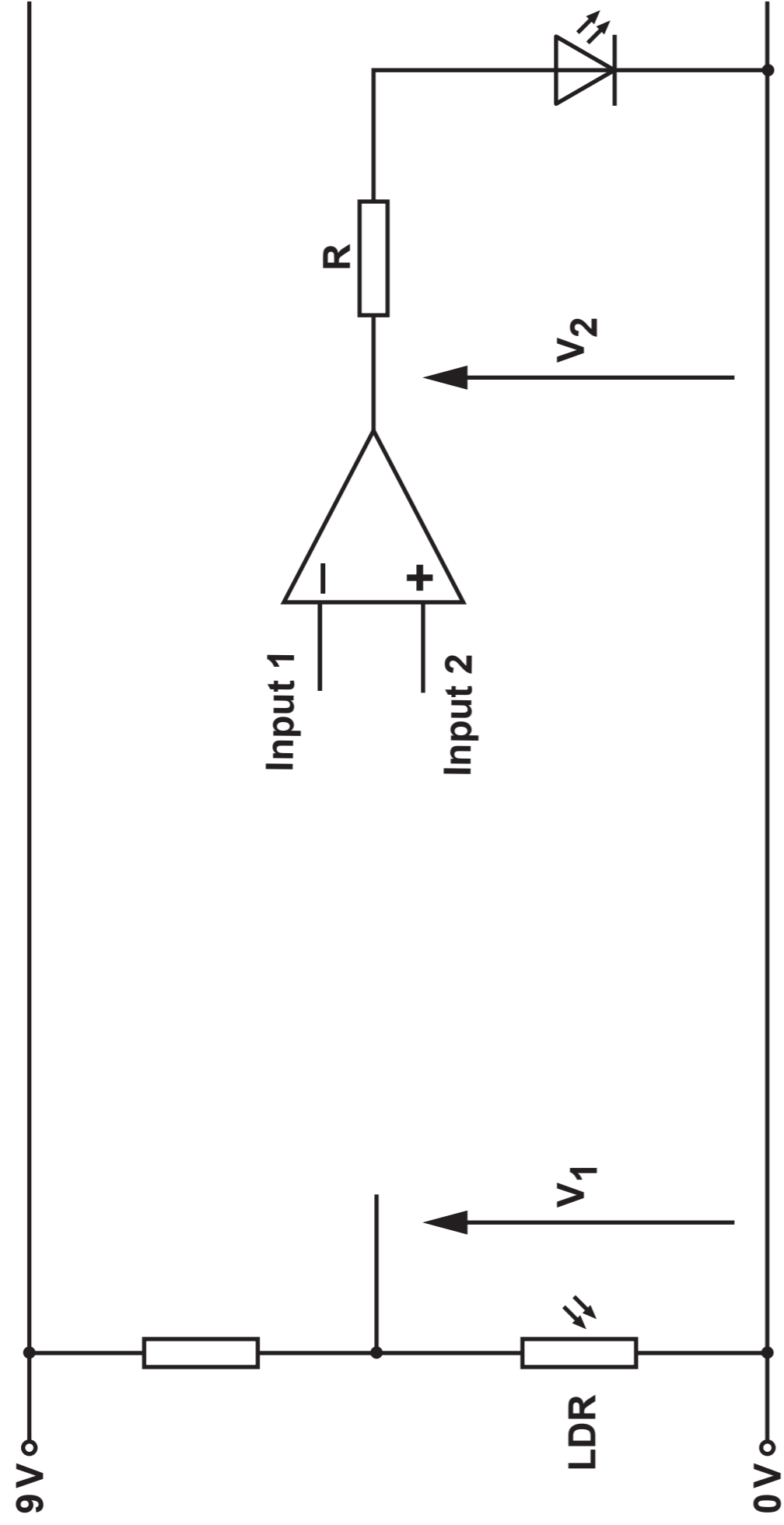

Clock signal

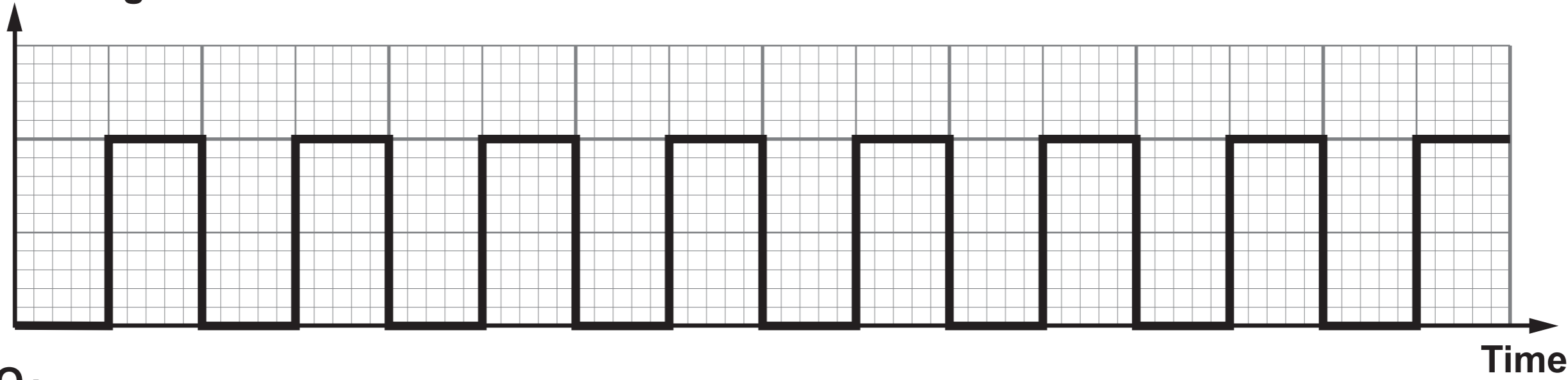

QA

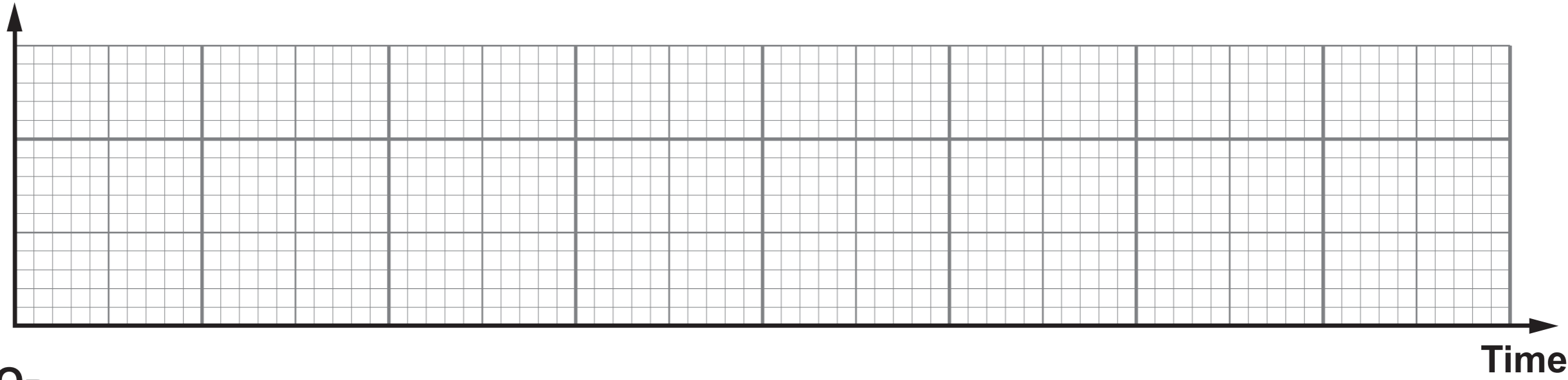

QB

