



GCE AS/A LEVEL

2420U20-1

MONDAY, 6 JUNE 2022 – MORNING

PHYSICS – AS UNIT 2

ELECTRICITY AND LIGHT

1 hour 30 minutes plus your additional time allowance

Surname: _____

First name(s): _____

Centre Number: _____

Candidate Number: **2** _____

For Examiner's use only

Question	Maximum Mark	Mark Awarded
1.	9	
2.	16	
3.	6	
4.	11	
5.	10	
6.	12	
7.	8	
8.	8	
Total	80	

(Turn over)

ADDITIONAL MATERIALS

In addition to this paper you will require a calculator and a DATA BOOKLET, provided separately.

ITEMS INCLUDED WITH QUESTION PAPER

A separate Diagram Booklet.

The Diagram Booklet MUST be handed in to the invigilators and sent for marking.

INSTRUCTIONS TO CANDIDATES

Use black ink, black ball – point pen, black felt tip or your usual method.

Write your name, centre number and candidate number in the spaces on the front cover.

Answer ALL questions.

Write your answers in the spaces provided.

If you run out of space use the additional pages at the back of the booklet taking care to number the question(s) correctly.

(Turn over)

INFORMATION FOR CANDIDATES

The total number of marks available for this paper is 80.

The number of marks is given in brackets at the end of each question or part – question.

The assessment of the quality of extended response (QER) will take place in question 3.

ANSWER ALL QUESTIONS.

1. **Look at Diagram 1 for Question 1 in the separate Diagram Booklet. Diagram 1 shows a circuit.**

Anwen sets up the circuit shown in order to investigate a cell. The variable resistor is adjusted and readings are obtained from the voltmeter and ammeter.

Look at Diagram 2 for Question 1 in the separate Diagram Booklet. Diagram 2 is a graph.

The readings are plotted as shown.

continued on the next page . . .

Question 1 continued

1. (a) The manufacturer claims that the emf of the cell is **1.50 V**. Explain, in terms of energy, what this statement means.

[2 marks]

continued on the next page . . .

(Turn over)

Question 1 continued

1. (b) An equation applying to a cell of emf, E , and internal resistance, r , is:

$$V = E - Ir$$

- (i) Explain how Anwen's graph is in good agreement with this equation.

[2 marks]

continued on the next page . . .

(Turn over)

Question 1 (b) continued

1. (b) (ii) Calculate the gradient of the line and hence determine a value for the cell's internal resistance.

[2 marks]

- (iii) Evaluate the manufacturer's claim that the emf is **1.50 V**.

[1 mark]

continued on the next page . . .

(Turn over)

Question 1 continued

1. (c) (i) Use the graph (Diagram 2) to determine the greatest current the cell can supply.

[1 mark]

- (ii) State the resistance of the variable resistor when the current is at its maximum.

[1 mark]

(Total for Question 1 = 9 marks)

(Turn over)

2. The current, I , in a wire of cross – sectional area, A , is given by the equation:

$$I = nAve$$

- (a) (i) State what the letter n represents in this equation.

[1 mark]

continued on the next page . . .

(Turn over)

Question 2 (a) continued

2. (a) (ii) Using a labelled diagram, derive the equation below.

$$I = nAve$$

Space for diagram.

(Turn over)

[4 marks]

continued on the next page . . .

(Turn over)

Question 2 (a) continued

2. (a) (iii) In a physics experiment there is a current of **1.8 A** in a nichrome wire of diameter **0.19 mm**.

For nichrome, $n = 9.0 \times 10^{28} \text{ m}^{-3}$.

Calculate the drift velocity.

[2 marks]

continued on the next page . . .

(Turn over)

Question 2 continued

2. (b) Look at the diagram for Question 2 (b) in the separate Diagram Booklet.

The nichrome wire is cut into different lengths to make three resistors.

The resistors are connected in the circuit as shown in the diagram. The battery has negligible internal resistance.

- (i) Explain, in clear steps, why the current, x , is **0.30 A**.

[3 marks]

(Turn over)

Question 2 (b) continued

2. (b) (ii) Calculate the pd across the supply.

[3 marks]

continued on the next page . . .

(Turn over)

Question 2 (b) continued

2. (b) (iii) Show that the power dissipated by the $12\ \Omega$ and $24\ \Omega$ parallel arrangement is ONE FIFTH that dissipated by the $40\ \Omega$ resistor.

[3 marks]

(Total for Question 2 = 16 marks)

(Turn over)

4. (a) Look at Diagram 1 and Diagram 2 for Question 4 (a) in the separate Diagram Booklet.

The diagrams are NOT drawn to scale.

Diagram 1 shows a modern version of Young's double slit experiment.

The array of light sensors is connected to circuitry that displays a graph of light intensity along the line AB.

This is shown in Diagram 2.

- (i) Calculate a value for the wavelength of light from the laser.

[3 marks]

4. (a) (ii) Each slit is several wavelengths wide. Suggest why the intensity of the bright fringes decreases the further the fringes are from the centre of the pattern.

[2 marks]

continued on the next page . . .

(Turn over)

Question 4 (a) continued

4. (a) (iii) A student suggests that replacing the laser with one that emits near infra – red (that is infra – red just beyond the end of the visible spectrum) will increase the fringe separation.

I. Explain whether or not the student is right.

[2 marks]

continued on the next page . . .

(Turn over)

Question 4 (a) (iii) continued

4. (a) (iii) II. State ONE way in which the fringe separation could be increased without changing the laser.

[1 mark]

(b) More than 200 years ago Thomas Young drew a conclusion from his ‘fringes’ experiment. It was not generally accepted for several years. State what conclusion Young drew, AND suggest what needed to be done by the scientific community for the conclusion to be accepted.

(Turn over)

[3 marks]

(Total for Question 4 = 11 marks)

(Turn over)

5. (a) Look at Diagram 1 for Question 5 (a) in the separate Diagram Booklet. Diagram 1 shows where two metal spheres, S_1 and S_2 , touch the surface of water (in a tray).

S_2 remains stationary while S_1 is made to vibrate up and down, so waves spread outwards from it across the water.

The wavelength of the waves is 20 mm.

Look at Diagram 2 for Question 5 (a) in the separate Diagram Booklet.

Diagram 2 shows a displacement – time graph for point P.

continued on the next page . . .

Question 5 (a) continued

5. (a) (i) Calculate the wave speed.

[2 marks]

continued on the next page . . .

(Turn over)

Question 5 (a) continued

5. (a) (ii) Look at the diagrams for Question 5 (a) (ii) in the separate Diagram Booklet.

S₁ and **S₂** are now made to vibrate **IN PHASE**, to act as wave sources of equal amplitude. Carefully sketch, on the lower two grids **ON THE DIAGRAM**, displacement – time graphs for point **P**, due to:

- I. waves from **S₂**

[1 mark]

- II. the superposition of waves from **S₁** and **S₂**

[1 mark]

continued on the next page . . .

(Turn over)

Question 5 (a) continued

5. (a) (iii) Look at the diagram for Question 5 (a) (iii) in the separate Diagram Booklet.

A student suggests that, with S_1 and S_2 vibrating as before, the displacement at Q (see diagram) will be zero all the time.

Evaluate whether or not she is correct, explaining your reasoning.

[3 marks]

(Turn over)

Question 5 continued

5. (b) Light of wavelength **590 nm** is incident normally on a plane diffraction grating. The centres of the grating's slits are **2 000 nm** apart.

(i) Calculate the angle to the normal at which **THIRD** order beams emerge.

[2 marks]

continued on the next page . . .

(Turn over)

Question 5 (b) continued

**5. (b) (ii) Look at the diagram for Question 5 (b) (ii) in the separate Diagram Booklet.
The diagram is NOT drawn to scale.**

The diagram shows light emerging AT THIS ANGLE from two adjacent slits in the grating.

State the value of X .

[1 mark]

(Total for Question 5 = 10 marks)

6. (a) The work function of the metal rubidium is 3.62×10^{-19} J.

Explain what this statement means.

[2 marks]

continued on the next page . . .

(Turn over)

Question 6 continued

6. (b) The minimum frequency of light that will eject electrons from a surface of work function ϕ is $\frac{\phi}{h}$.

Explain in terms of photons why this is so.

[3 marks]

continued on the next page . . .

(Turn over)

Question 6 continued

6. (c) Look at the diagram for Question 6 (c) in the separate Diagram Booklet.

The diagram shows a circuit.

A student has the task of determining whether or not the emitting electrode in a vacuum photocell might be made of rubidium. A light source of known frequency (6.34×10^{14} Hz) is provided.

The student sets up the circuit shown in the diagram.

continued on the next page . . .

Question 6 (c) continued

The student shines the light on the emitting electrode and increases the pd from zero until the current has just fallen to zero. She records this pd (**THE STOPPING PD**) and repeats the procedure, obtaining these results.

Stopping pd / V
0.381
0.366
0.388
0.373
0.371
0.380

continued on the next page . . .

(Turn over)

Question 6 (c) continued

- 6. (c) (i) Calculate the mean value and the ABSOLUTE uncertainty of the stopping pd, giving your answers to an appropriate number of significant figures.**

[3 marks]

continued on the next page . . .

(Turn over)

35

[4 marks]

(Total for Question 6 = 12 marks)

(Turn over)

7. Look at the diagram for Question 7 in the separate Diagram Booklet.

The diagram shows a simplified energy level diagram for the amplifying medium of a 4 – level laser. The lasing transition occurs between level **U** and level **L**.

(a) (i) The laser is pumped to create a population inversion between level **U** and level **L**.

State what is meant by a population inversion for THIS laser.

[1 mark]

continued on the next page . . .

(Turn over)

Question 7 (a) continued

7. (a) (ii) DRAW THREE ARROWS on the diagram to show the transitions required for this population inversion to be sustained.

[1 mark]

(iii) Explain why a population inversion is needed for light amplification to take place.

[3 marks]

continued on the next page . . .

(Turn over)

Question 7 continued

- 7. (b) Determine whether or not visible light will be produced by the lasing transition from level **U** to level **L**, giving your reasoning.**

[3 marks]

(Total for Question 7 = 8 marks)

(Turn over)

8. (a) (i) Explain how MULTIMODE DISPERSION arises in a glass fibre.

[2 marks]

(ii) State what feature of a MONOMODE fibre prevents multimode dispersion.

[1 mark]

continued on the next page . . .

(Turn over)

Question 8 continued

8. (b) Look at the diagram for Question 8 (b) in the separate Diagram Booklet.

The diagram is NOT drawn to scale.

The diagram shows a cross – section of a multimode fibre.

(i) Calculate the largest angle, θ , to the axis (see diagram) at which light can travel for long distances through the core of a multimode fibre, if the refractive index of the core is 1.574, and that of the cladding is 1.550

(Turn over)

[3 marks]

continued on the next page . . .

(Turn over)

Question 8 (b) continued

8. (b) (ii) Explain what would happen to light entering the fibre at an angle to the axis greater than the angle calculated in part (b) (i).

[2 marks]

(Total for Question 8 = 8 marks)

END OF PAPER

TOTAL 80 MARKS

(Turn over)



GCE AS/A LEVEL

2420U20-1

MONDAY, 6 JUNE 2022 – MORNING

PHYSICS – AS UNIT 2

ELECTRICITY AND LIGHT

**The Diagram Booklet MUST be handed in
to the invigilators and sent for marking.**

Diagram Booklet

Surname: _____

First name(s): _____

Centre Number: _____

Candidate Number: 2 _____

Question 1

Diagram 1

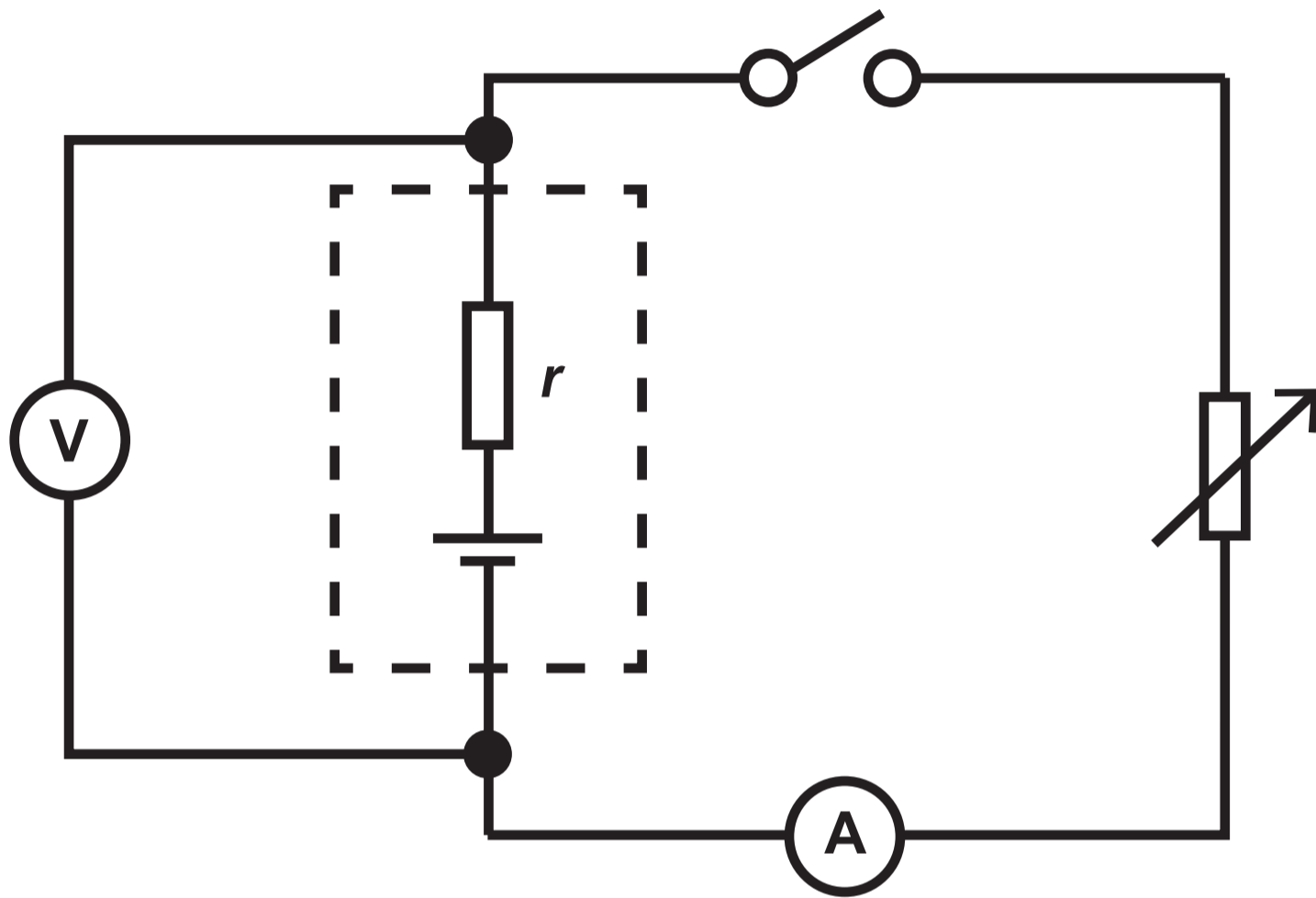

Question 1

Diagram 2

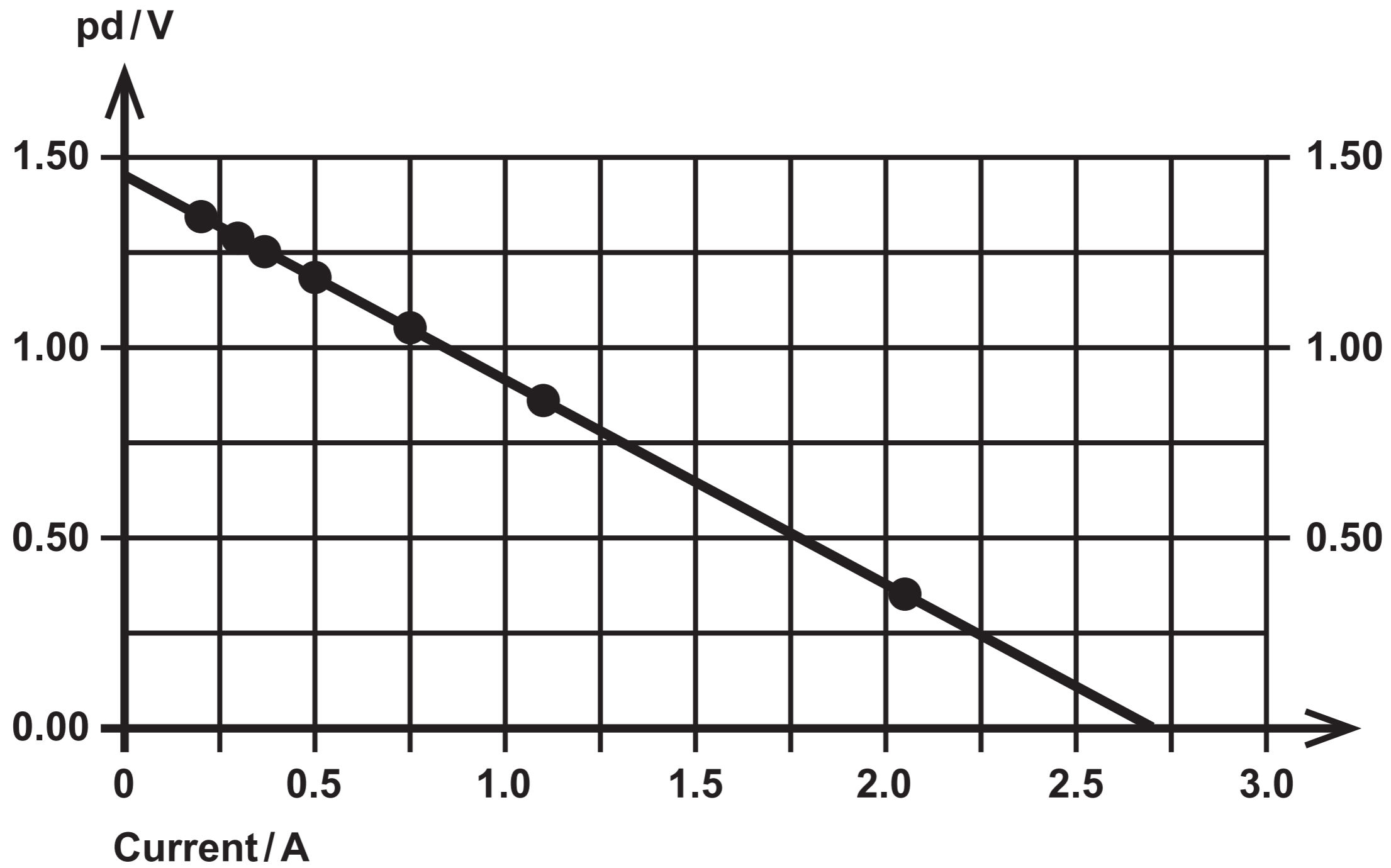

Question 2 (b)

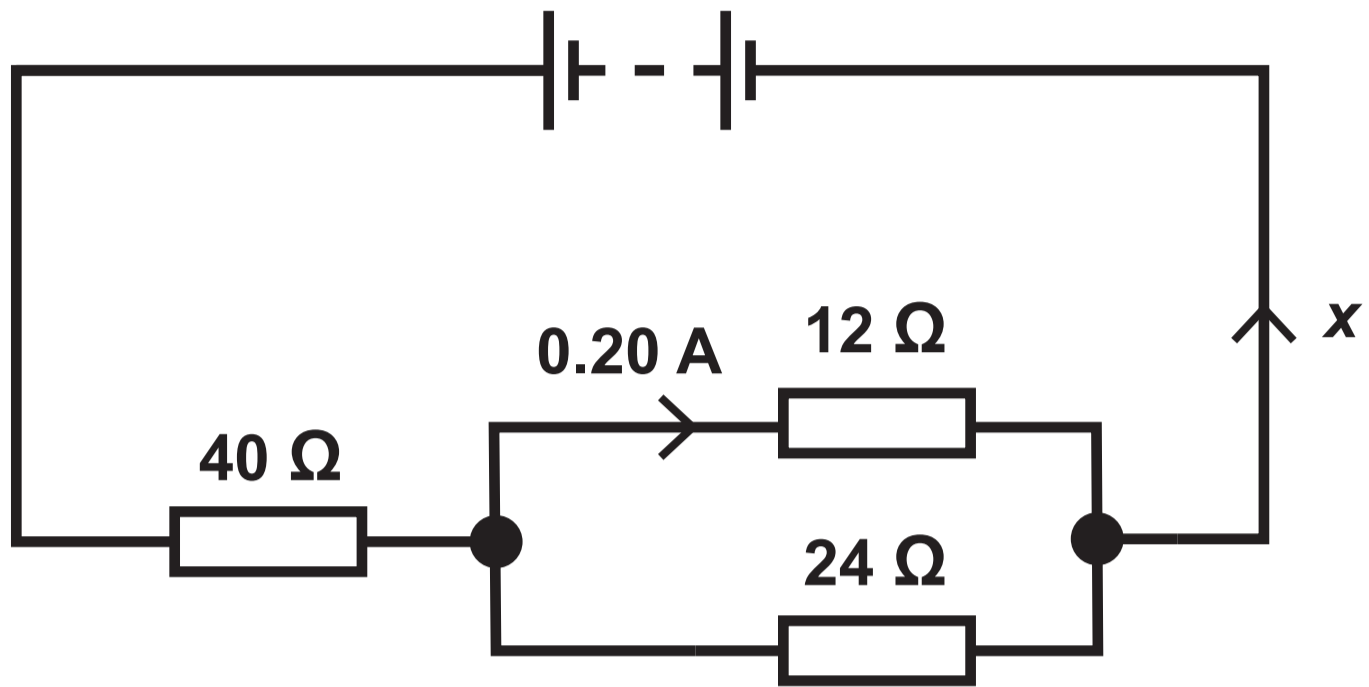

Question 4 (a)

Diagrams NOT drawn to scale

Diagram 1

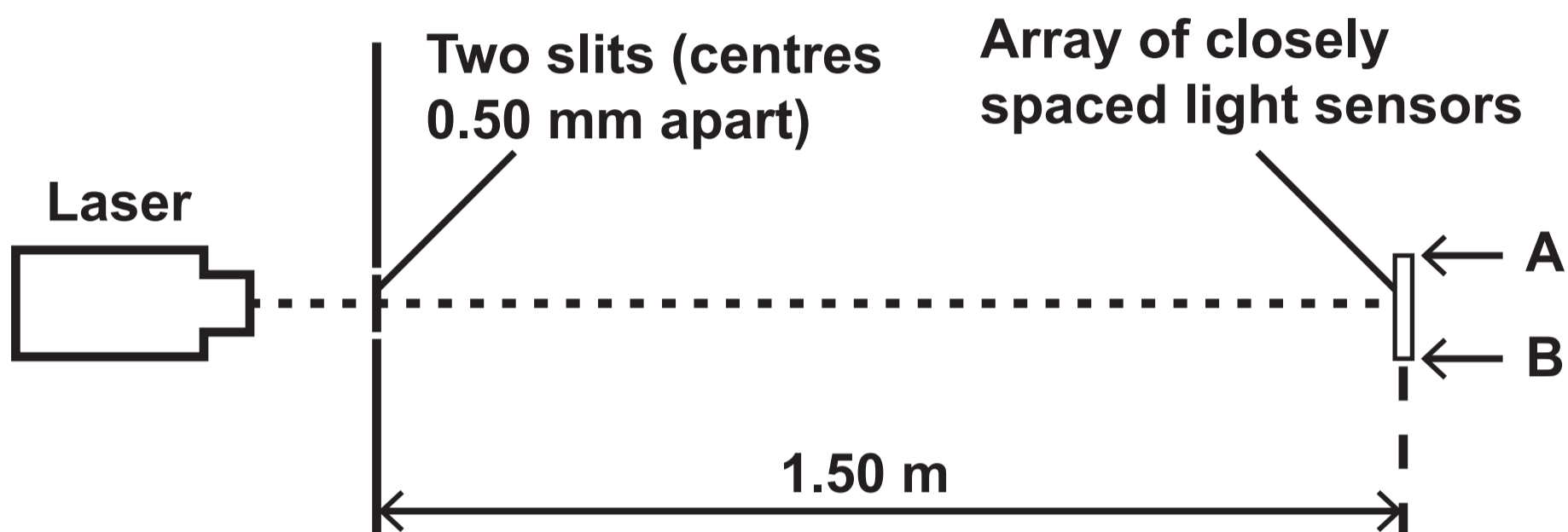
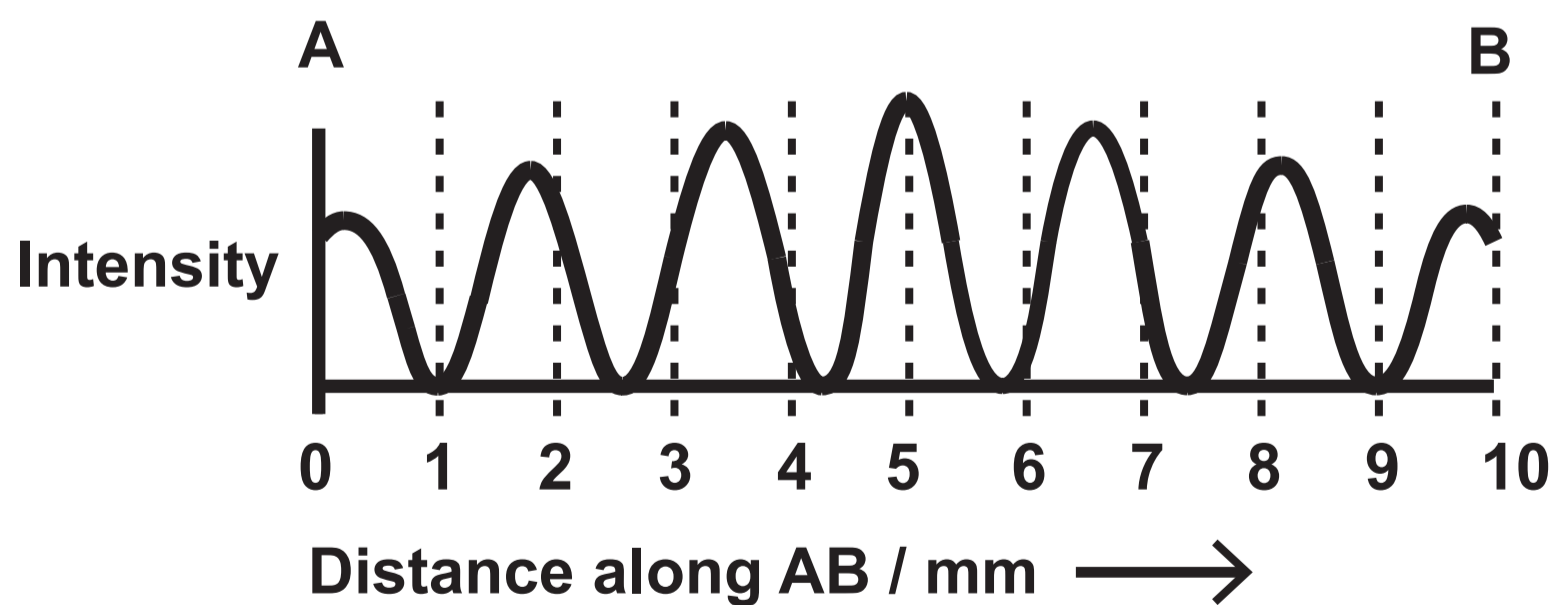

Diagram 2



Question 5 (a)

Diagram 1

VIEW FROM ABOVE

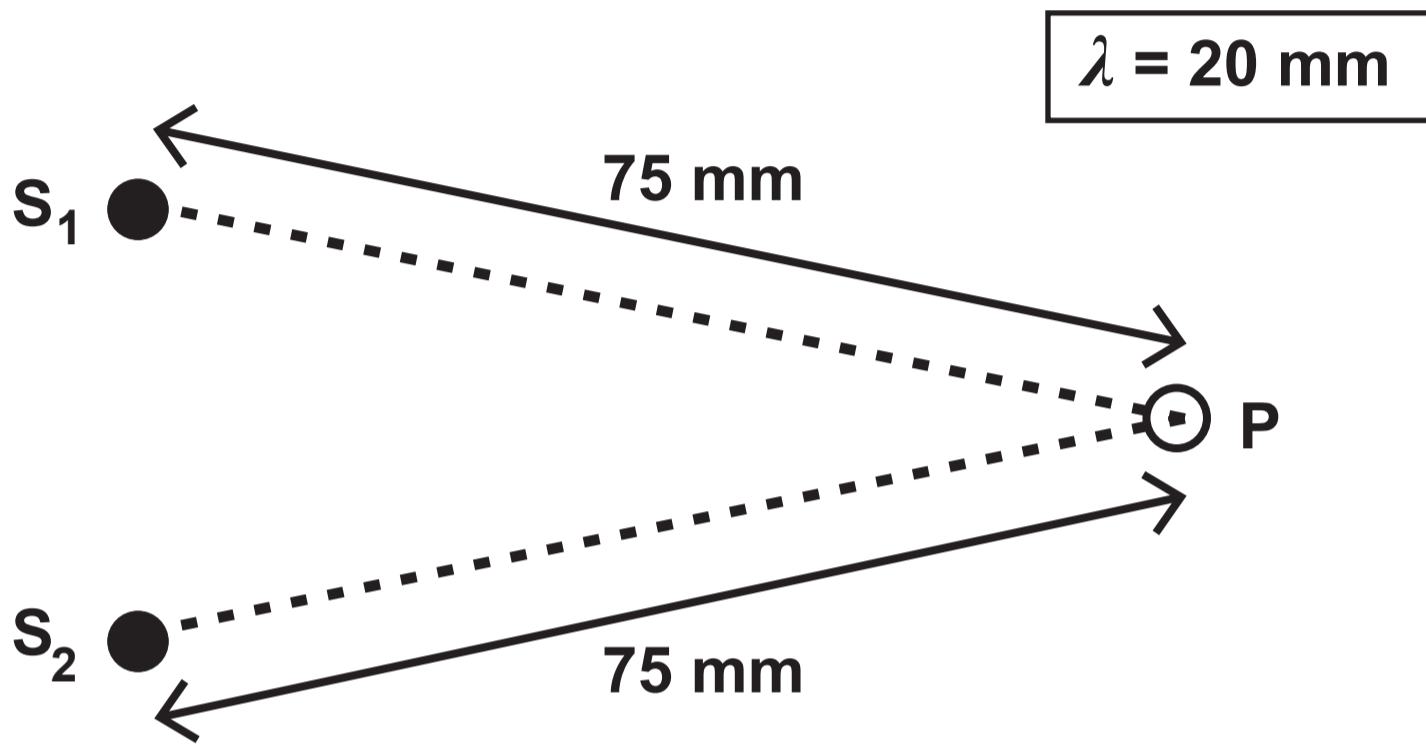

Question 5 (a)

Diagram 2

Displacement at P
due to S_1 / mm

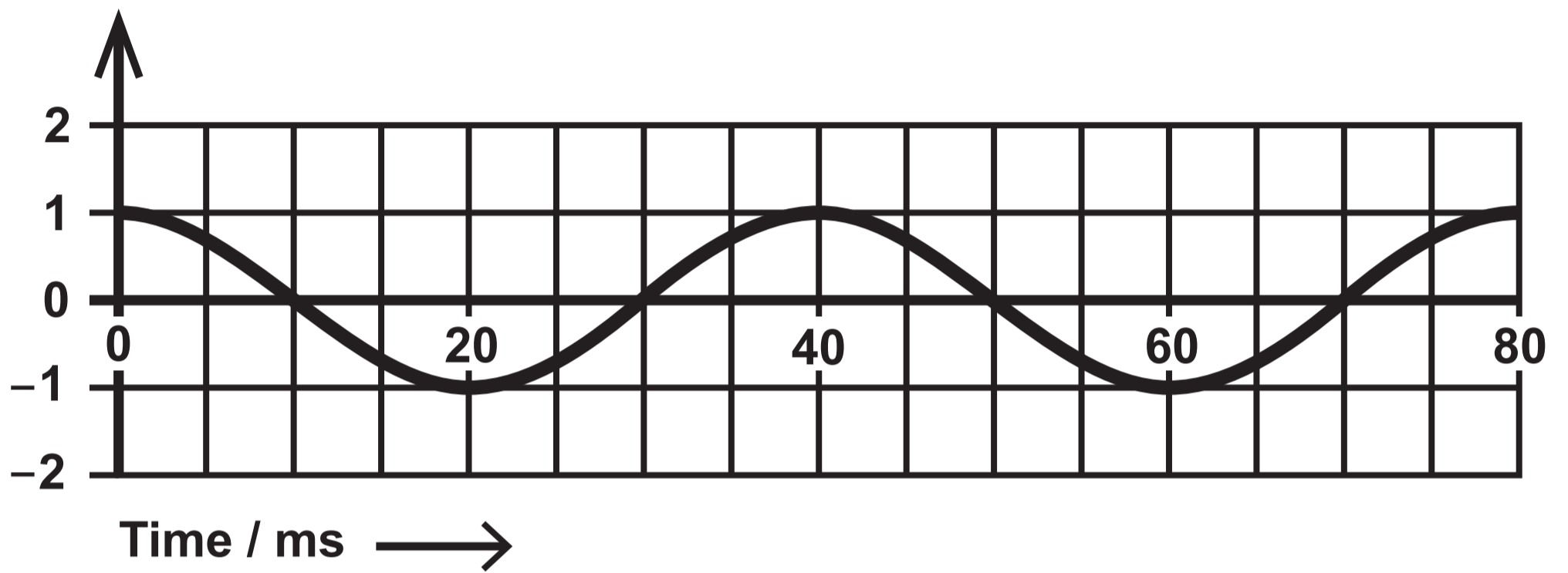

Question 5 (a) (ii)

Displacement at P due to S_1 / mm

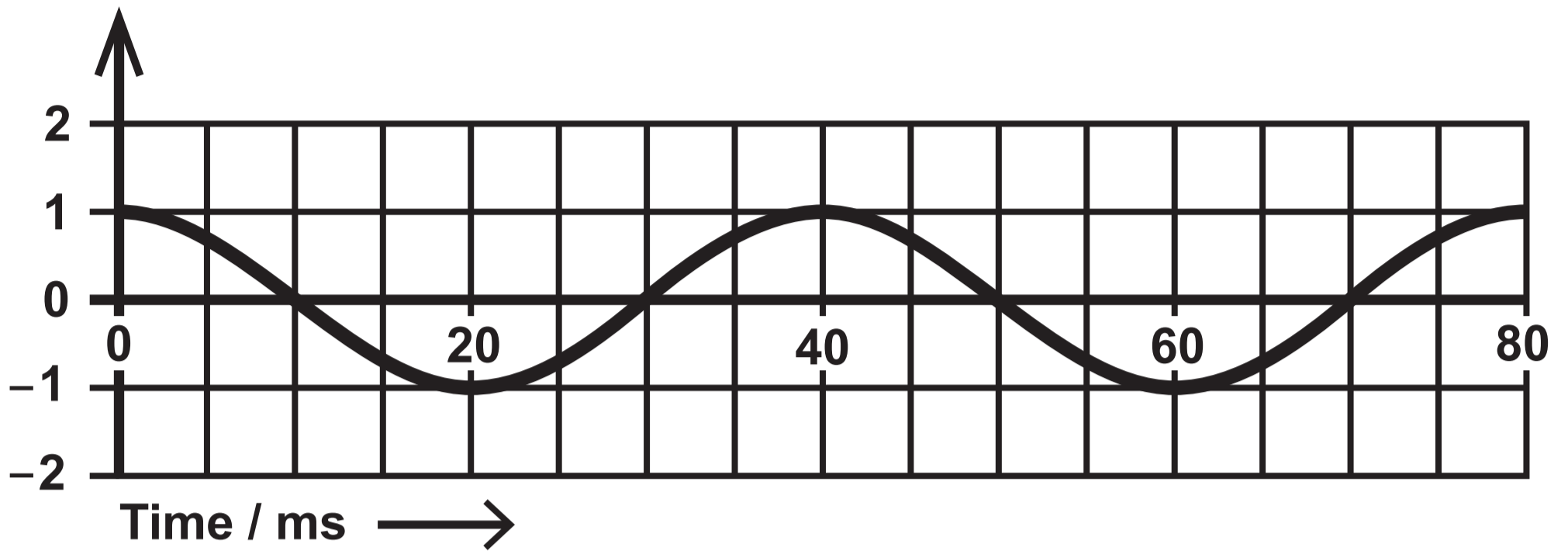

Displacement at P due to S_2 / mm

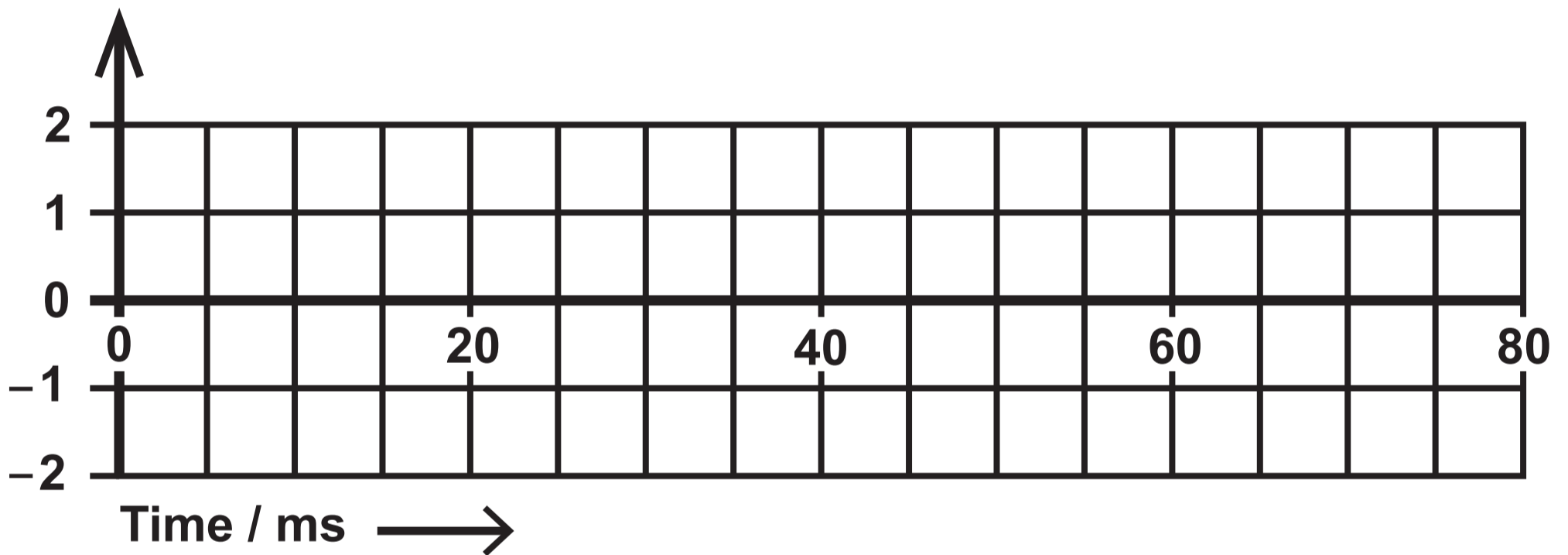

Displacement at P due to S_1 and S_2 together / mm

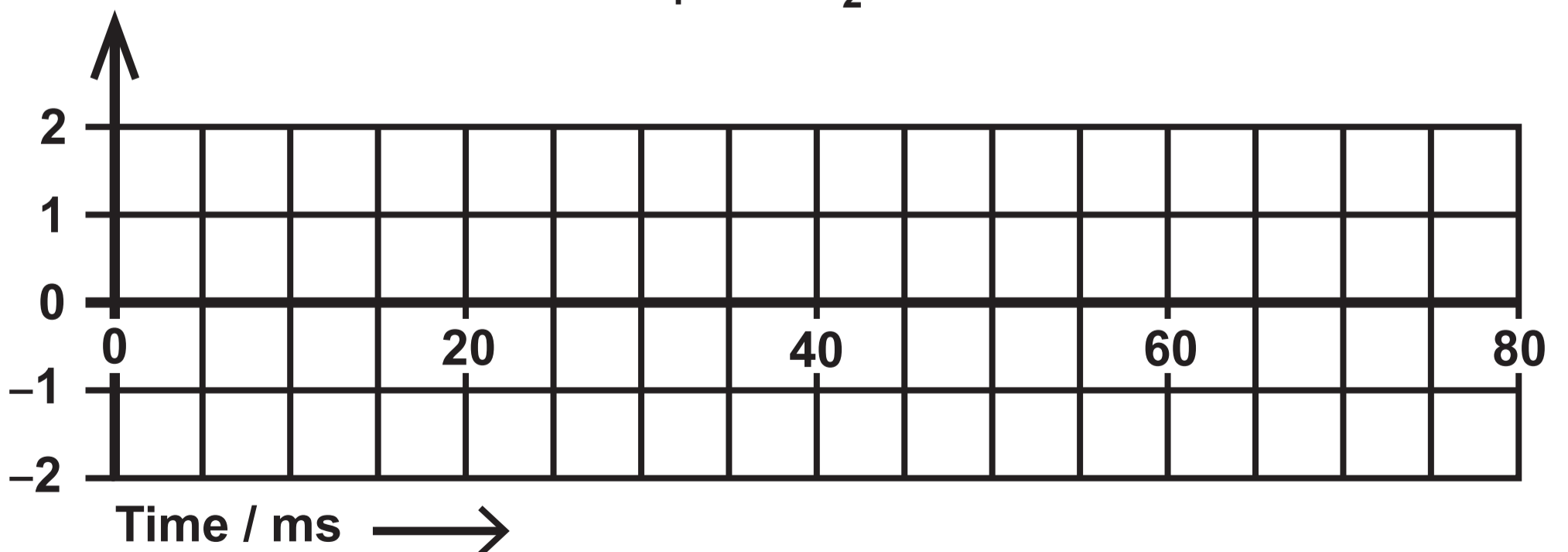

Question 5 (a) (iii)

VIEW FROM ABOVE

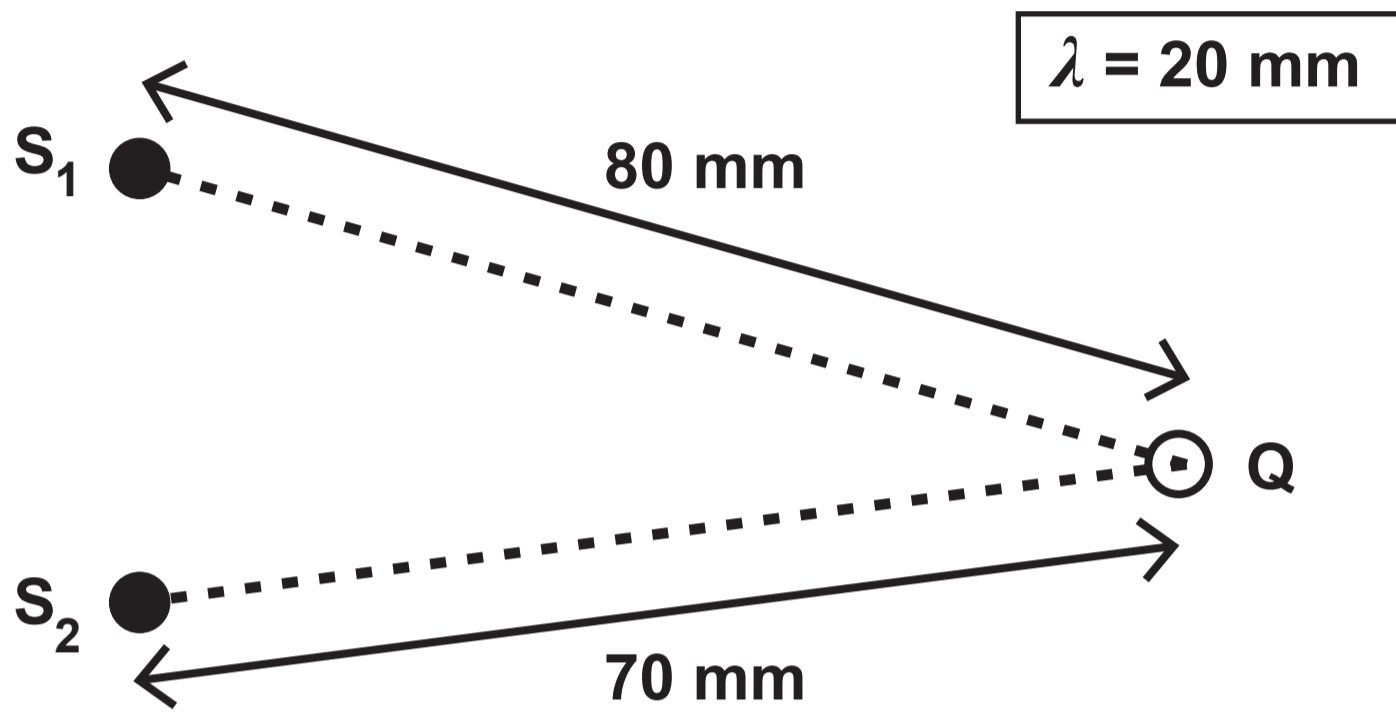

Question 5 (b) (ii)

Diagram NOT drawn to scale

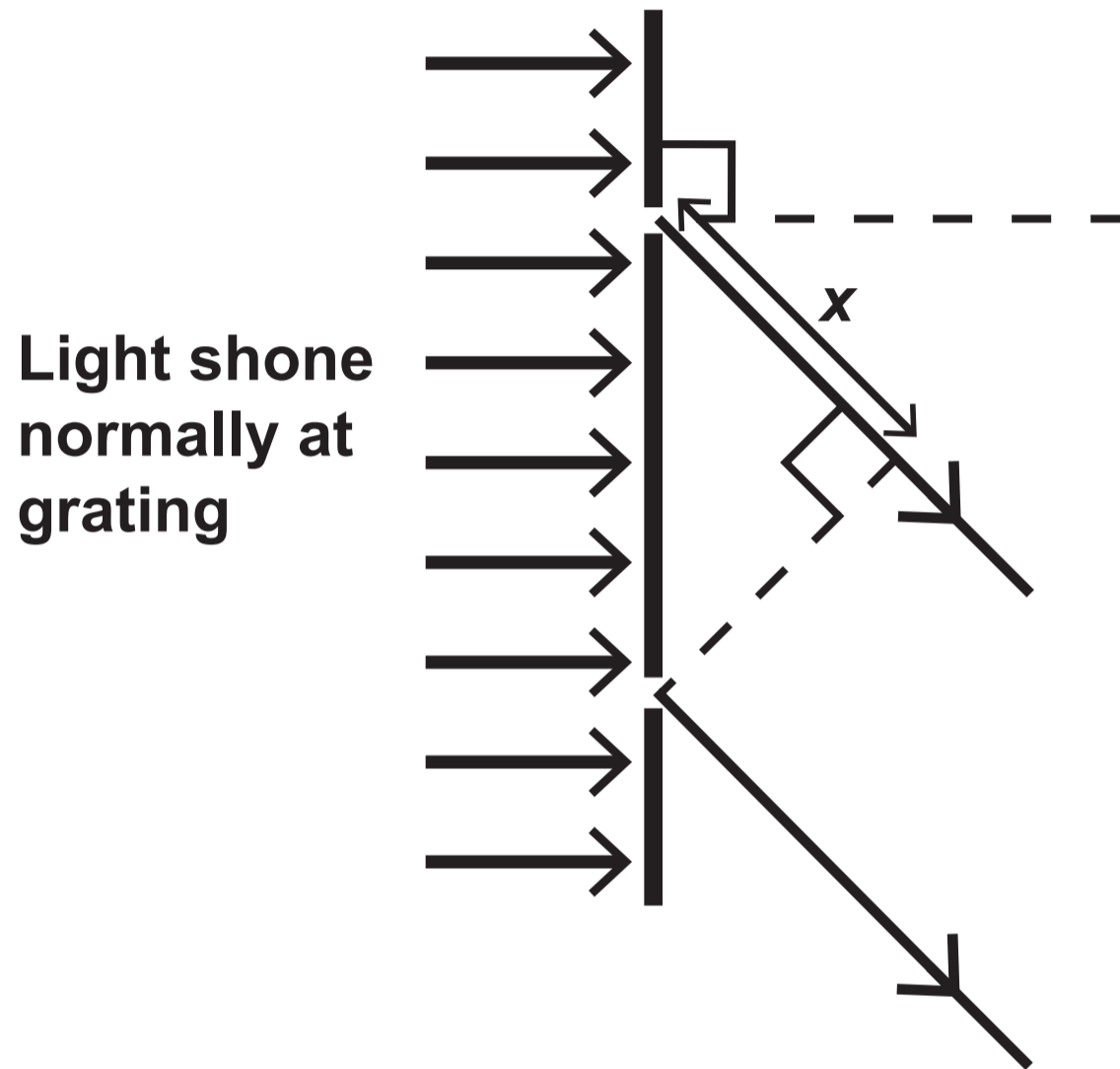

Question 6 (c)

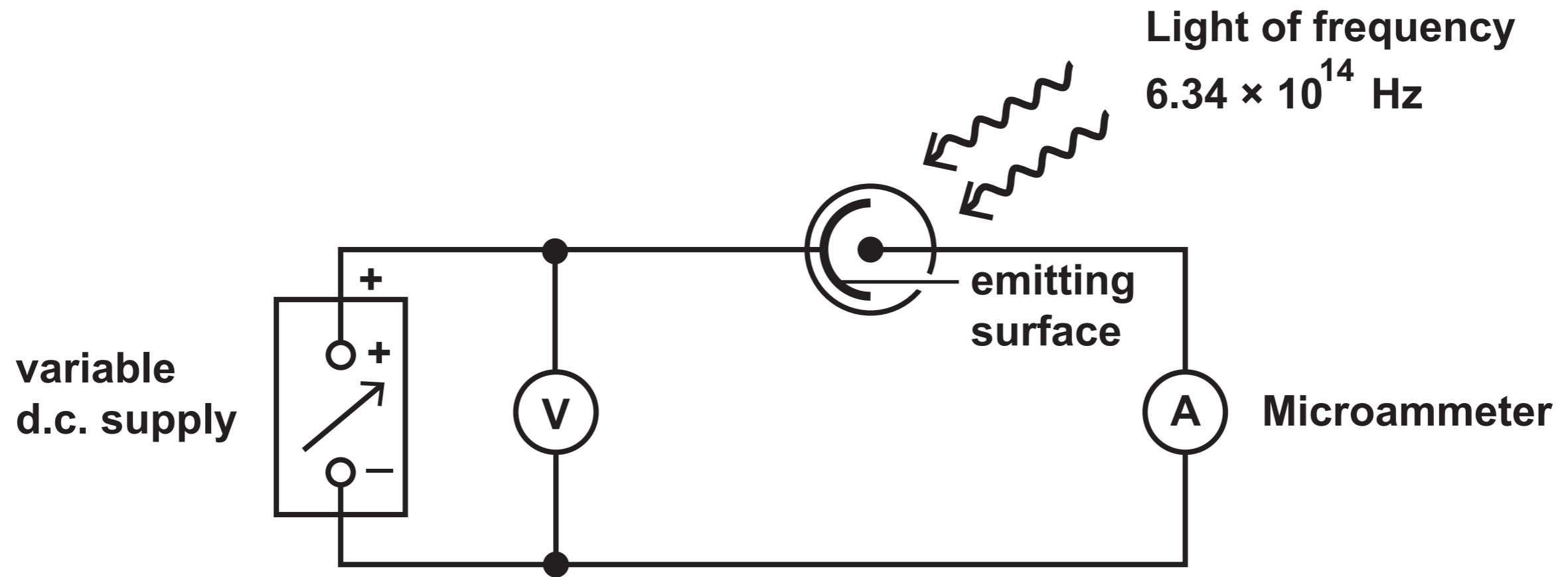

Question 7

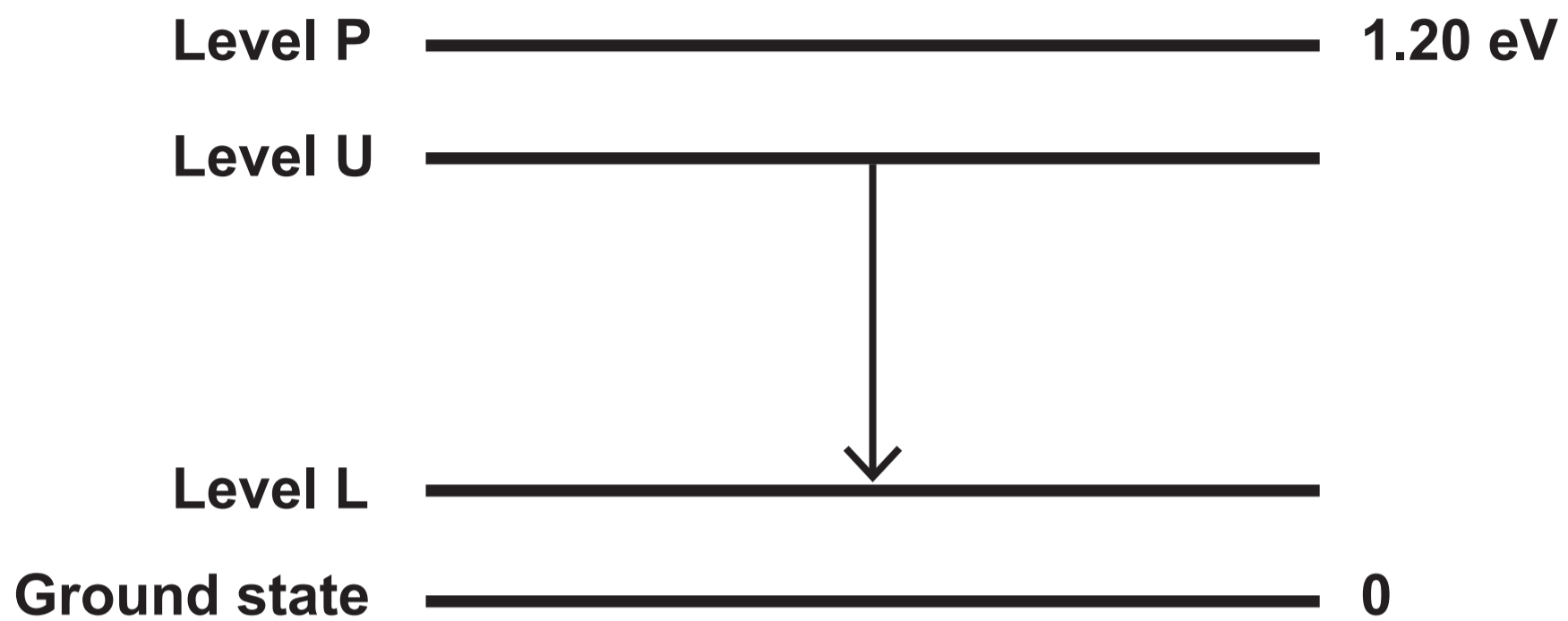

Question 8 (b)

Diagram NOT drawn to scale

