

GCSE 3300U60-1



MATHEMATICS

UNIT 2: CALCULATOR – ALLOWED

HIGHER TIER

THURSDAY, 6 JUNE

2019 – MORNING

1 hour 45 minutes

**(plus your additional
time allowance)**

**A CALCULATOR
WILL BE REQUIRED
FOR THIS PAPER**

For Examiner's use only		
Question	Maximum Mark	Mark Awarded
1.	8	
2.	6	
3.	2	
4.	3	
5.	4	
6.	3	
7.	5	
8.	4	
9.	3	
10.	4	
11.	2	
12.	4	
13.	3	
14.	5	
15.	2	
16.	4	
17.	5	
18.	3	
19.	6	
20.	4	
Total	80	

Surname:	
Other Names:	
Centre Number:	
Candidate Number:	0

ADDITIONAL MATERIALS

A ruler, a protractor and a pair of compasses may be required.

**ITEMS INCLUDED WITH QUESTION
PAPER**

A separate Formula List.

A separate Diagram Booklet.

A spare Diagram Booklet.

Models for Question 20.

(Turn over)

INSTRUCTIONS TO CANDIDATES

Use black ink, black ball – point pen, black felt tip or your usual method.

Write your name, centre number and candidate number in the spaces on the front cover.

Answer ALL questions.

Write your answers in the spaces provided.

If you run out of space, use the continuation pages at the back of the booklet. Question numbers must be given for all work written on the continuation page(s).

Take π as 3.14 or use the π button on your calculator.

(Turn over)

INFORMATION FOR CANDIDATES

You should give details of your method of solution when appropriate.

Unless stated, diagrams are not drawn to scale.

Scale drawing solutions will not be acceptable where you are asked to calculate.

The number of marks is given in brackets at the end of each question or part – question.

In question 2, the assessment will take into account the quality of your linguistic and mathematical organisation, communication and accuracy in writing.

(Turn over)

1. (a) Write down the n th term of the following sequence.

8, 11, 14, 17,

[2 marks]

continued on the next page . . .

(Turn over)

Question 1 continued

- 1. (c) A rectangle has
a length of $(x + 5)$ cm and
a width of $(2x - 3)$ cm.
Its perimeter is 46 cm.
Calculate the value of x .**

(Turn over)

8

[4 marks]

(Turn over)

- 2. IN THIS QUESTION, YOU WILL BE ASSESSED ON THE QUALITY OF YOUR ORGANISATION, COMMUNICATION AND ACCURACY IN WRITING.**

Look at the diagram for Question 2 in the separate Diagram Booklet.

The diagram is NOT drawn to scale.

In triangle XYZ ,

$$**$XY = 25.6 \text{ cm}$**$$

$$**$XZ = 12.8 \text{ cm}$**$$

$$**$ZY = 22.7 \text{ cm}$**$$

continued on the next page . . .

(Turn over)

Question 2 continued

**Is it possible to draw a
RIGHT – ANGLED triangle with
the measurements shown
in the diagram?**

**You must use calculations
(not a scale drawing) to support
your answer.**

You must show all your working.

(Turn over)

3. (a) Look at the diagram for Question 3 (a) in the separate Diagram Booklet.

The diagram is a Venn Diagram.

Which of the following sets represents the SHADED area in the Venn Diagram shown?
Circle your answer.

A'	$A \cup B$	B'
$A \cap B$	$A' \cap B$	$A \cup B'$

[1 mark]

continued on the next page . . .

(Turn over)

Question 3 continued

3. (b) Look at the diagram for Question 3 (b) in the separate Diagram Booklet.

The diagram is a Venn Diagram.

Which of the following sets represents the SHADED area in the Venn Diagram shown?
Circle your answer.

A'	$A \cup B$	B'
$A \cap B$	$A' \cap B$	$A \cup B'$

[1 mark]

(Turn over)

4. Look at the following set of four numbers.

5 8 10 13

Find another set of four numbers so that:

- the range has increased by 2**
- the mean remains the same**
- the median has decreased by 1**

You may use some of the numbers from the original set, but NOT exactly the same four numbers.

My four numbers are

[3 marks]
(Turn over)

5. Look at the diagram for Question 5 in the separate Diagram Booklet.

The diagram shows two pie charts.

A company has 3 sites based in Wales. One is in Carno, one is in Holyhead and one is in Porth.

The pie charts show the distribution of its 128 female staff and 72 male staff.

A person is chosen at random from the company's 200 staff members.

What is the probability that this person works at the Porth site?

6. Look at the diagram for Question 6 in the separate Diagram Booklet. The diagram is NOT drawn to scale.

PQR is a right – angled triangle.

PR = 16.7 cm,

QR = 9.6 cm.

Calculate the size of angle *QPR*.

(Turn over)

23

[3 marks]

(Turn over)

7. The Morgan family and the Smith family are on holiday in Aberystwyth. There are 7 adults and 2 children in the Morgan family. There are 4 adults and 3 children in the Smith family.

Both families visit a Craft Centre.

The entry price to the Craft Centre is £ x for adults and £ y for children.

The total cost for the

Morgan family is £41.50

The total cost for the

Smith family is £29.75

continued on the next page . . .

(Turn over)

Question 7 continued

Form two equations in terms of x and y .

Solve your equations, using an algebraic method, to find the entry price for adults and the entry price for children.

(Turn over)

The adult entry price (£ x) =

£ _____

The child entry price (£ y) =

£ _____

[5 marks]

(Turn over)

8. A solution of the equation

$$2x^3 + x - 10 = 0$$

lies between 1 and 2

Use the method of trial and improvement to find this solution correct to 1 decimal place.

You must show all your working.

[4 marks]

(Turn over)

(Turn over)

**9. When a number is reduced by 15%
the answer is 6154**

What is the original number?

(Turn over)

34

[3 marks]

(Turn over)

10. Look at the diagram for Question 10 in the separate Diagram Booklet. The diagram is NOT drawn to scale.

ABCD is a cyclic quadrilateral in a circle with centre ***O***.

Angle ***ABC*** = 126°

Write down the size of each of the angles ***x*** and ***y***.

You must give a reason for each of your answers.

x = _____^o

Reason: _____

(Turn over)

$y =$ _____^o

Reason: _____

[4 marks]

(Turn over)

11. Look at the diagram for Question 11 in the separate Diagram Booklet. The diagram shows a triangle on a grid.

Enlarge the given triangle by a scale factor of -3 using point *A* as the centre of enlargement.

[2 marks]

(Turn over)

40

[2 marks]

(Turn over)

13. A car travels 300 km, measured correct to the nearest 5 km.

It travels this distance in 6 hours, measured correct to the nearest hour.

Calculate the least possible average speed of the car.

Give your answer in km/h, correct to 2 decimal places.

(Turn over)

14. Look at the diagram for Question 14 in the separate Diagram Booklet.

The diagram is NOT drawn to scale.

The diagram shows a triangle ABC and a circle with centre A .

The points B and D lie on the circumference of the circle.

The radius of the circle is 8 cm.

The length of the line AC is 19 cm.

The area of triangle ABC is 70 cm^2

Calculate the area of the sector ABD .

(Turn over)

15. Look at the diagram for Question 15 in the separate Diagram Booklet.

The diagram shows four quadratic graphs labelled Graph A, Graph B, Graph C and Graph D.

Nine equations are also given.

Match each graph to its equation.

One has been completed for you.

Graph A is equation 5

Graph B is equation _____

Graph C is equation _____

Graph D is equation _____

[2 marks]

(Turn over)

16. (a) Look at the diagram for Question 16 (a) in the separate Diagram Booklet.

Sketch the curve $y = \sin x$ on the axes shown in the diagram.

You must indicate any important values on the y – axis.

[2 marks]

continued on the next page . . .

(Turn over)

[2 marks]

(Turn over)

17. A raffle is held at a school fair and a total of 100 tickets are sold.

Angharad buys three of the tickets and Meirion buys one ticket.

Tickets are selected at random and not replaced.

The first prize to be awarded is a calculator.

The second prize to be awarded is a voucher.

No other prizes are awarded.

continued on the next page . . .

(Turn over)

Question 17 continued

17. (a) Calculate the probability that Angharad wins the calculator and Meirion wins the voucher.

(Turn over)

[2 marks]

continued on the next page . . .

(Turn over)

Question 17 continued

**17. (b) Calculate the probability that
no one wins a prize apart from
Angharad or Meirion.**

55

[3 marks]

(Turn over)

18. Look at the diagram for Question 18 in the separate Diagram Booklet.

The diagram is NOT drawn to scale.

Triangle ABC has sides

$AB = 17$ cm, $AC = 13$ cm

and $BC = 23$ cm, as shown

in the diagram.

Calculate the size of angle CAB .

(Turn over)

19. Use the quadratic formula to solve

$$(3x - 2)^2 = (x + 1)(x + 2)$$

Give your answers correct to

2 decimal places.

You must show all your working.

(Turn over)

(Turn over)

[6 marks]

(Turn over)

20. Ask for the models for Question 20.

The models are NOT made to scale.

There are two models:

Solid A and Solid B.

The models represent

two similar solids.

Solid A has a base area of 47 cm^2

Solid B has a base area of 199 cm^2

The volume of the smaller solid

is 350 cm^3

Calculate the volume of the

larger solid.

GCSE

3300U60-1



MATHEMATICS

UNIT 2: CALCULATOR – ALLOWED

HIGHER TIER

THURSDAY, 6 JUNE 2019 – MORNING

Diagram Booklet

Surname:	
Other Names:	
Centre Number:	
Candidate Number:	0

Question 2

Diagram NOT drawn to scale

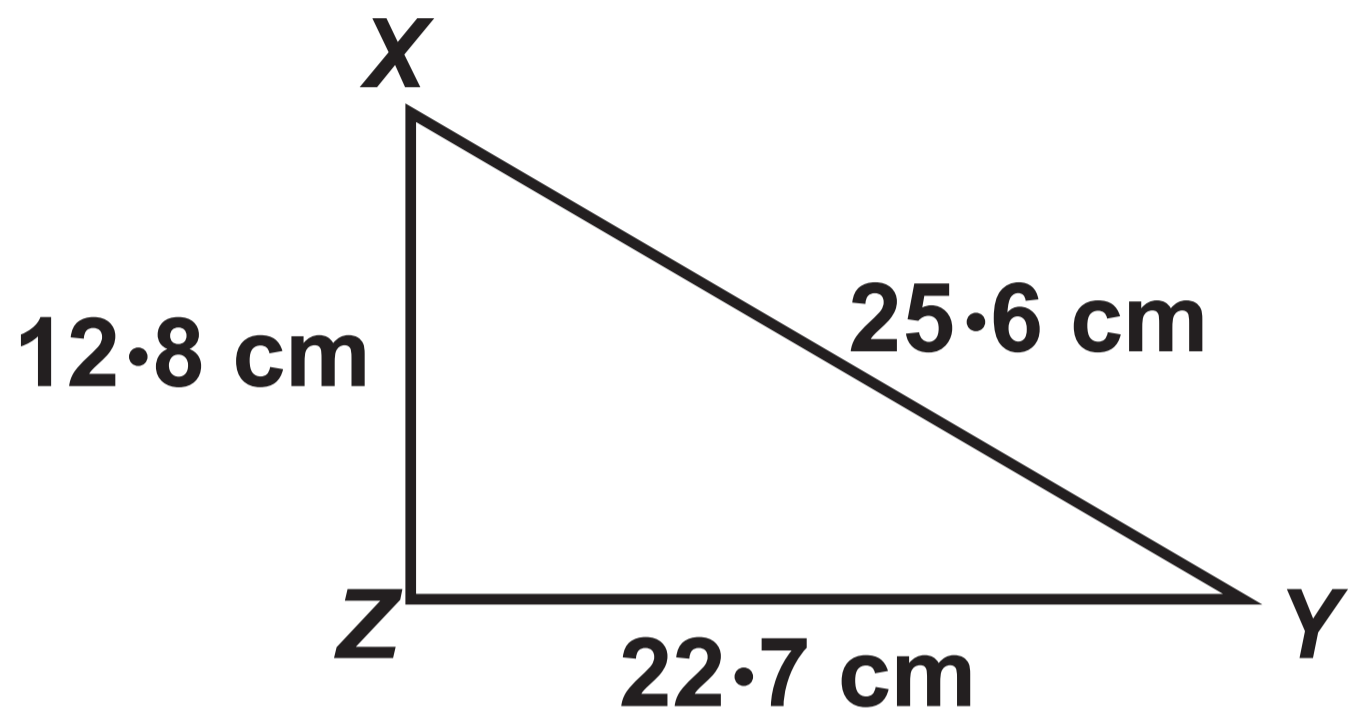

Question 3 (a)

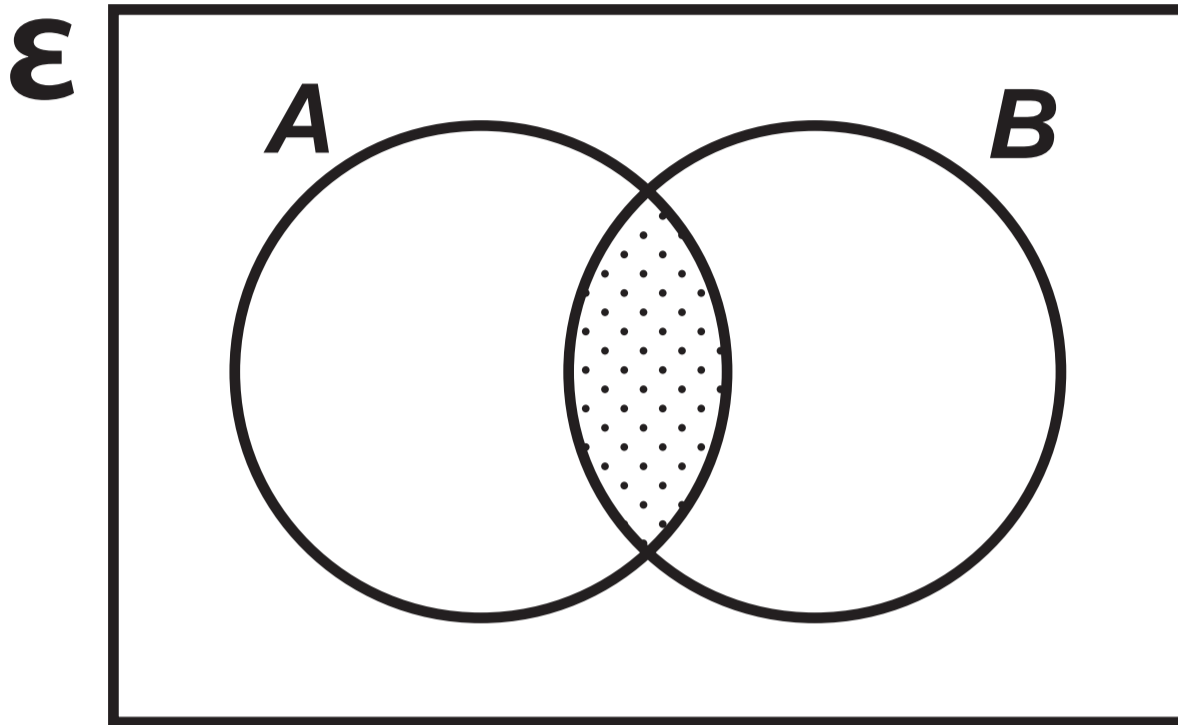

Question 3 (b)

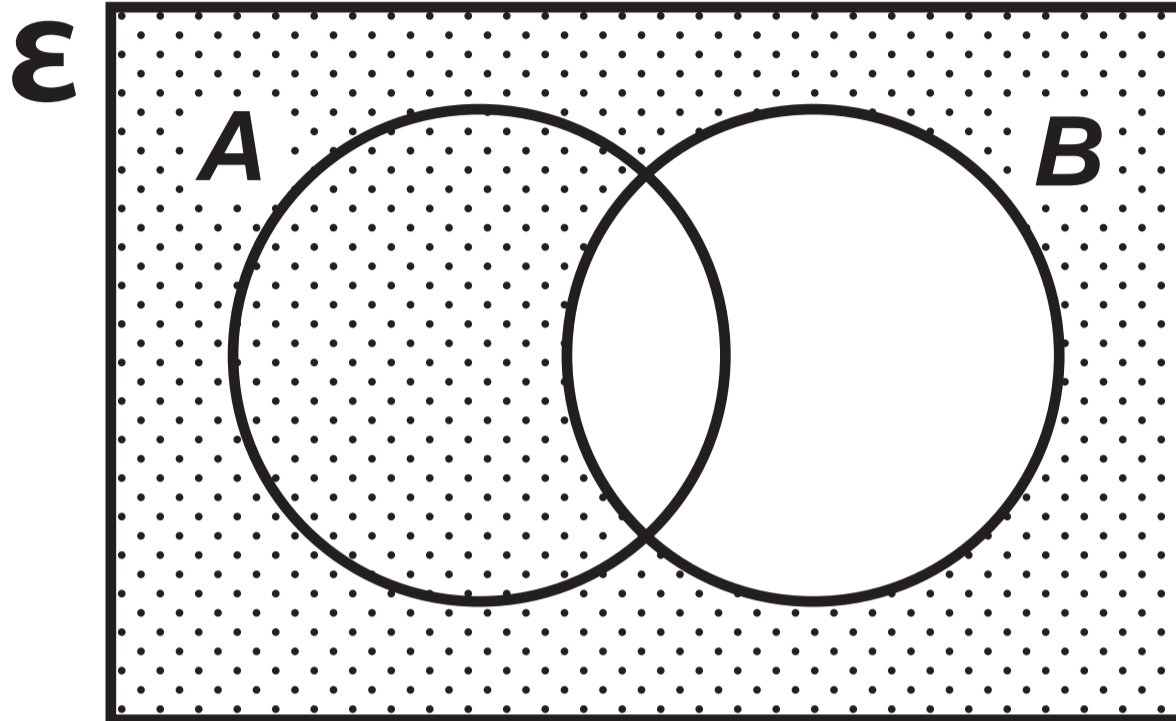

Question 5

Pie chart 1
128 female staff

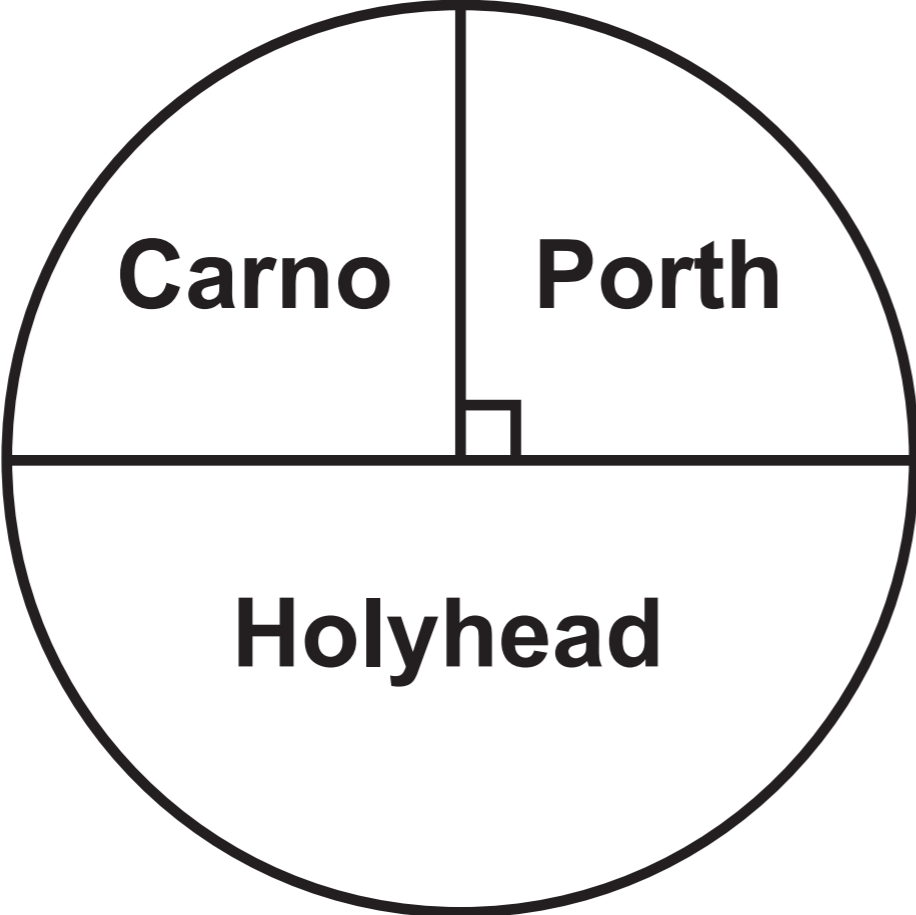

Pie chart 2
72 male staff

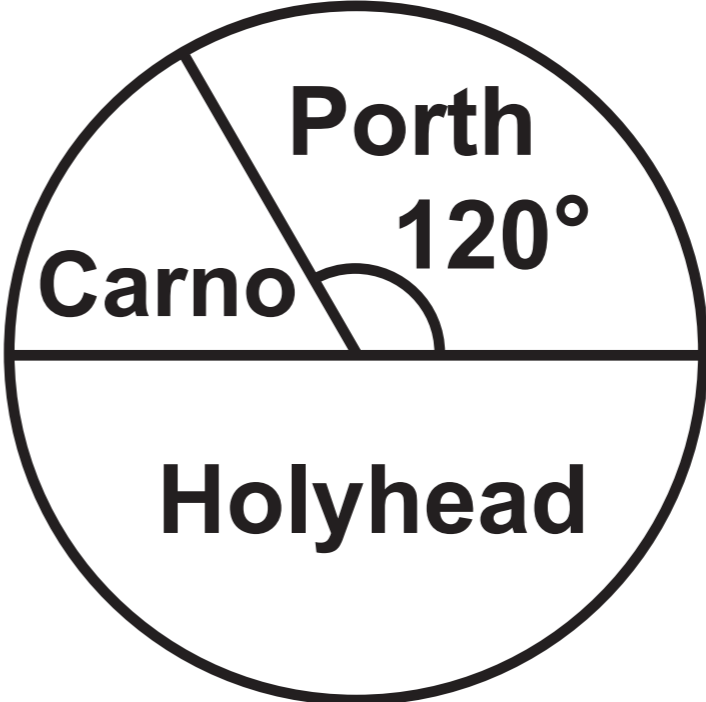

Question 6

Diagram NOT drawn to scale

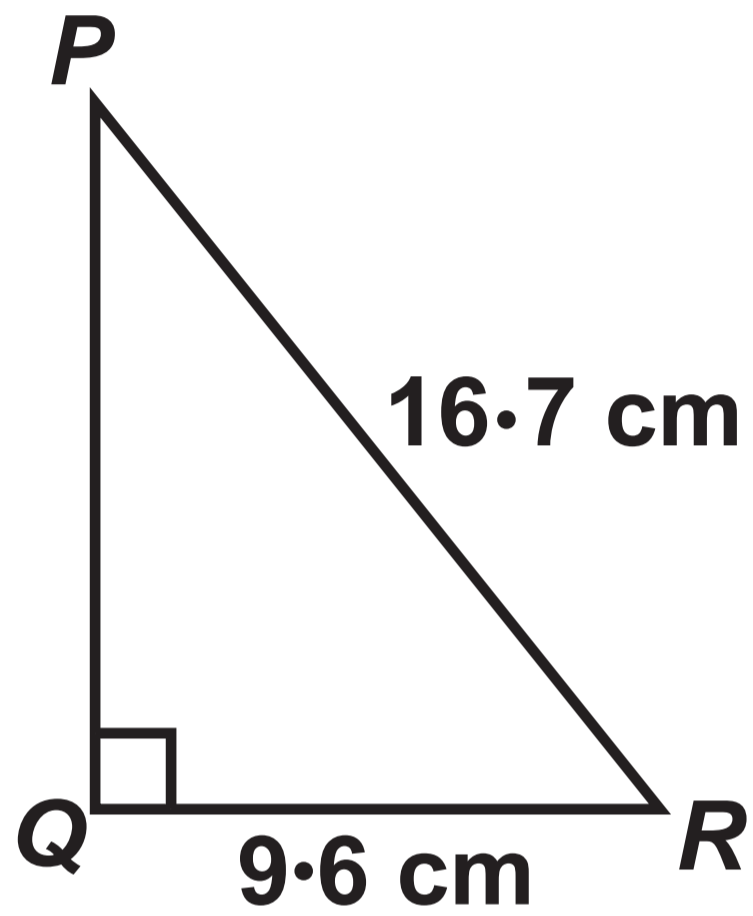

Question 10

Diagram NOT drawn to scale

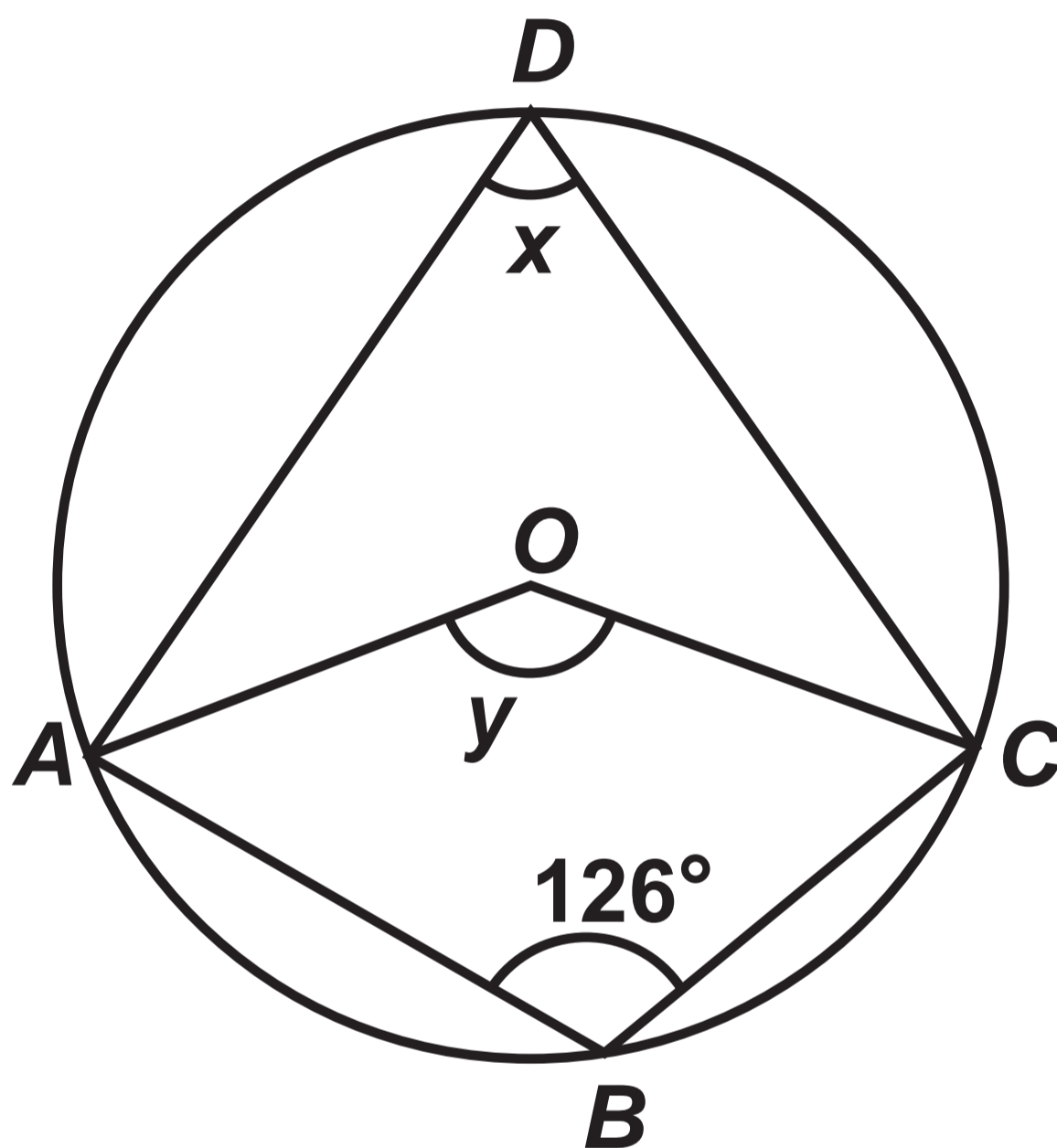

Question 11

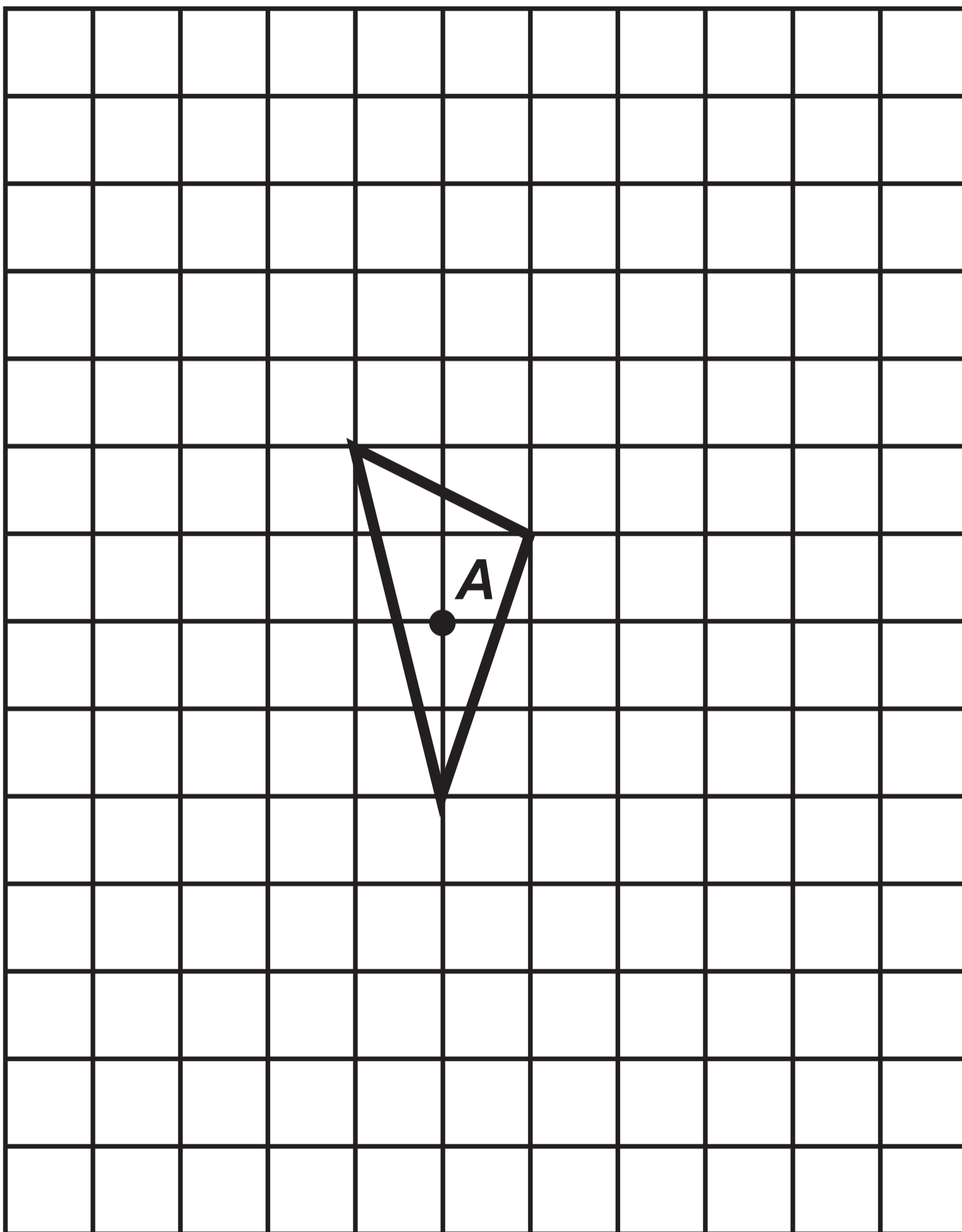

Question 14

Diagram NOT drawn to scale

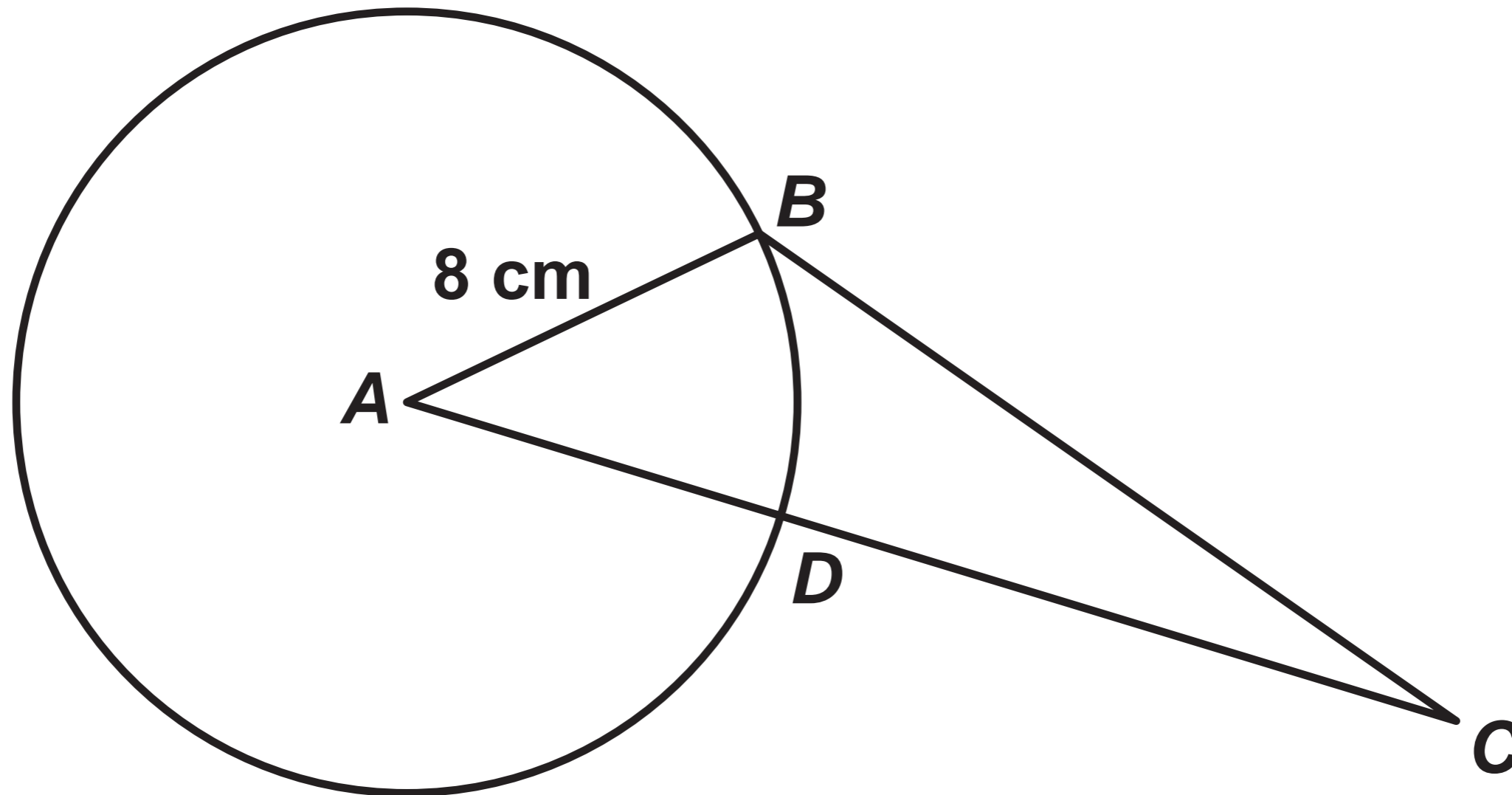

Question 15

Graph A

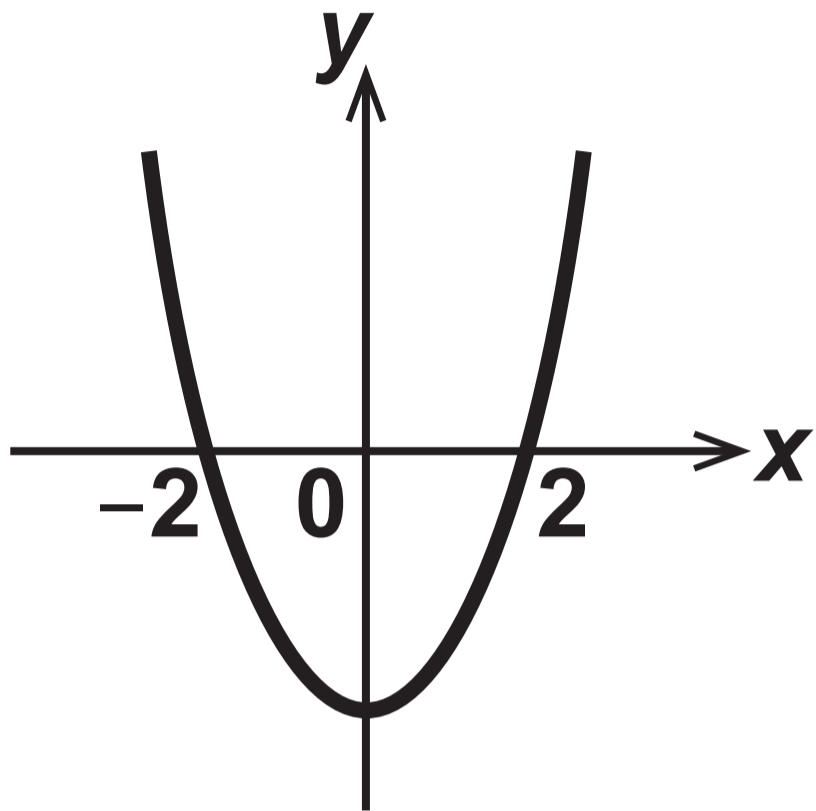

Graph B

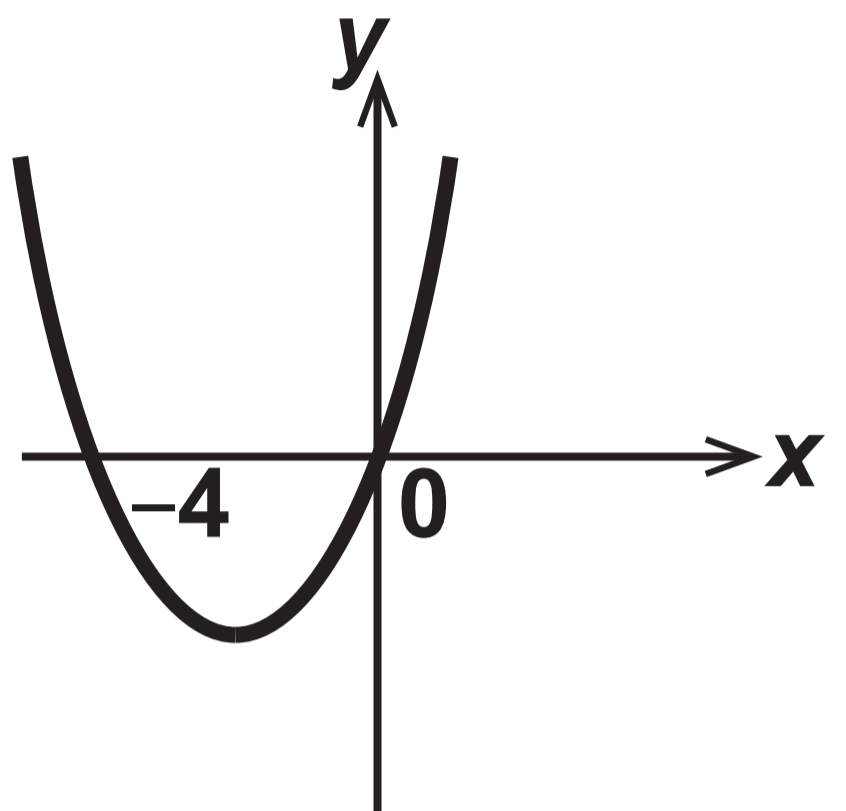

Graph C

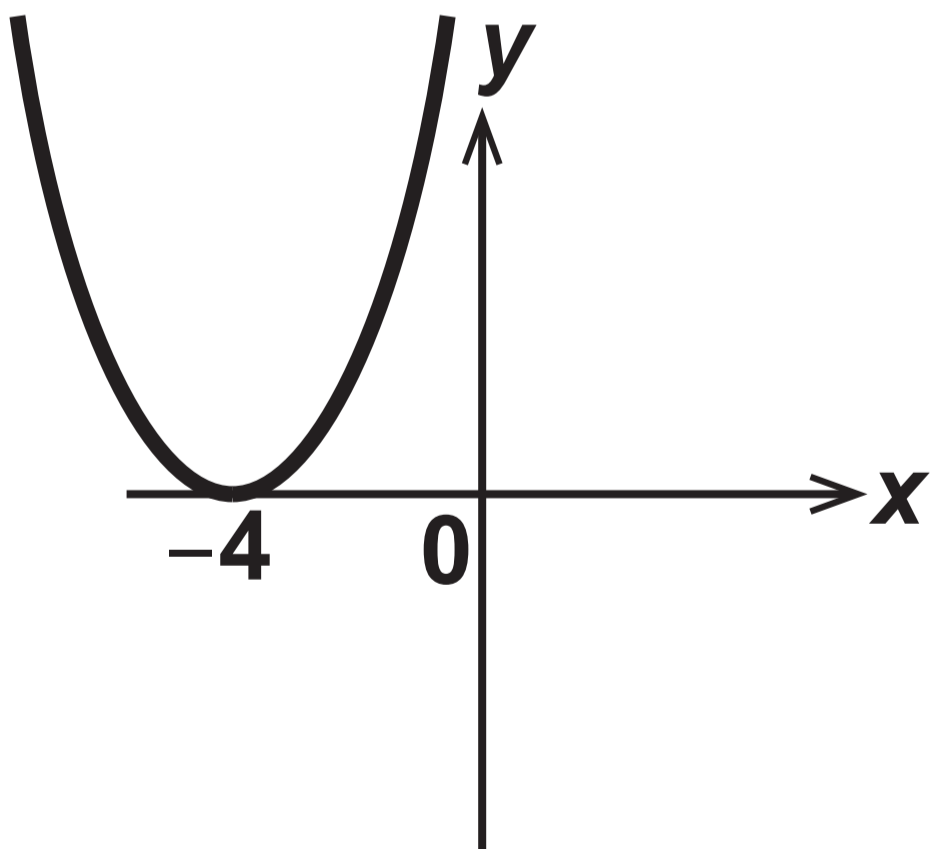

Graph D

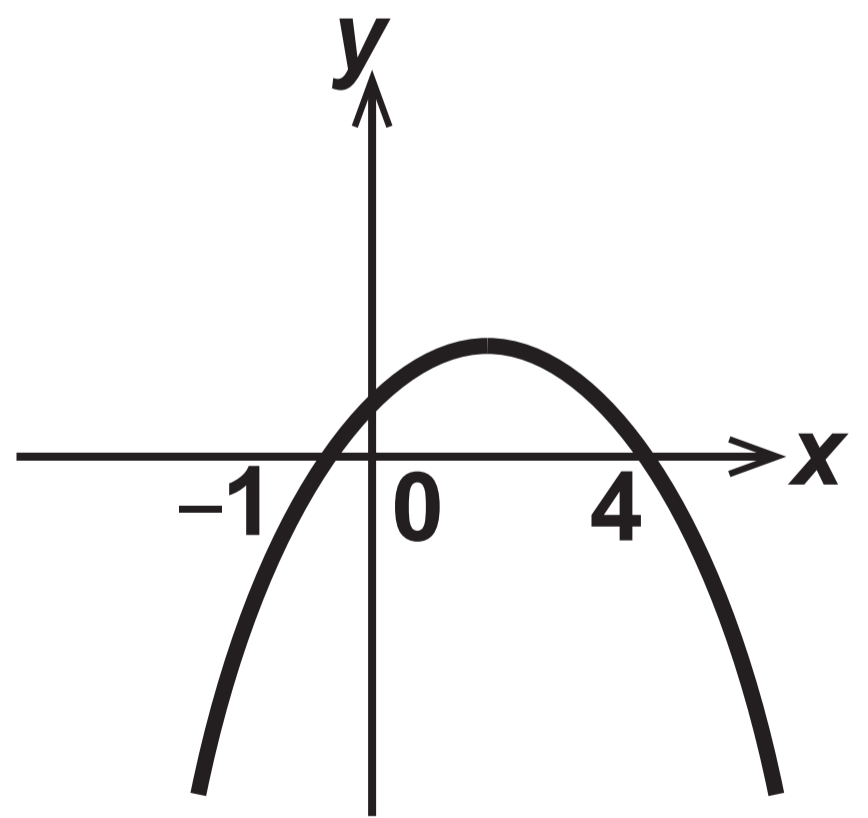

Question 15

EQUATIONS

1	$y = (x + 1)(x - 4)$
2	$y = (x - 4)^2$
3	$y = x(x + 4)$
4	$y = (x - 1)(x + 4)$
5	$y = (x - 2)(x + 2)$
6	$y = x(x - 4)$
7	$y = (x + 1)(4 - x)$
8	$y = (1 - x)(x + 4)$
9	$y = (x + 4)^2$

Question 16 (a)

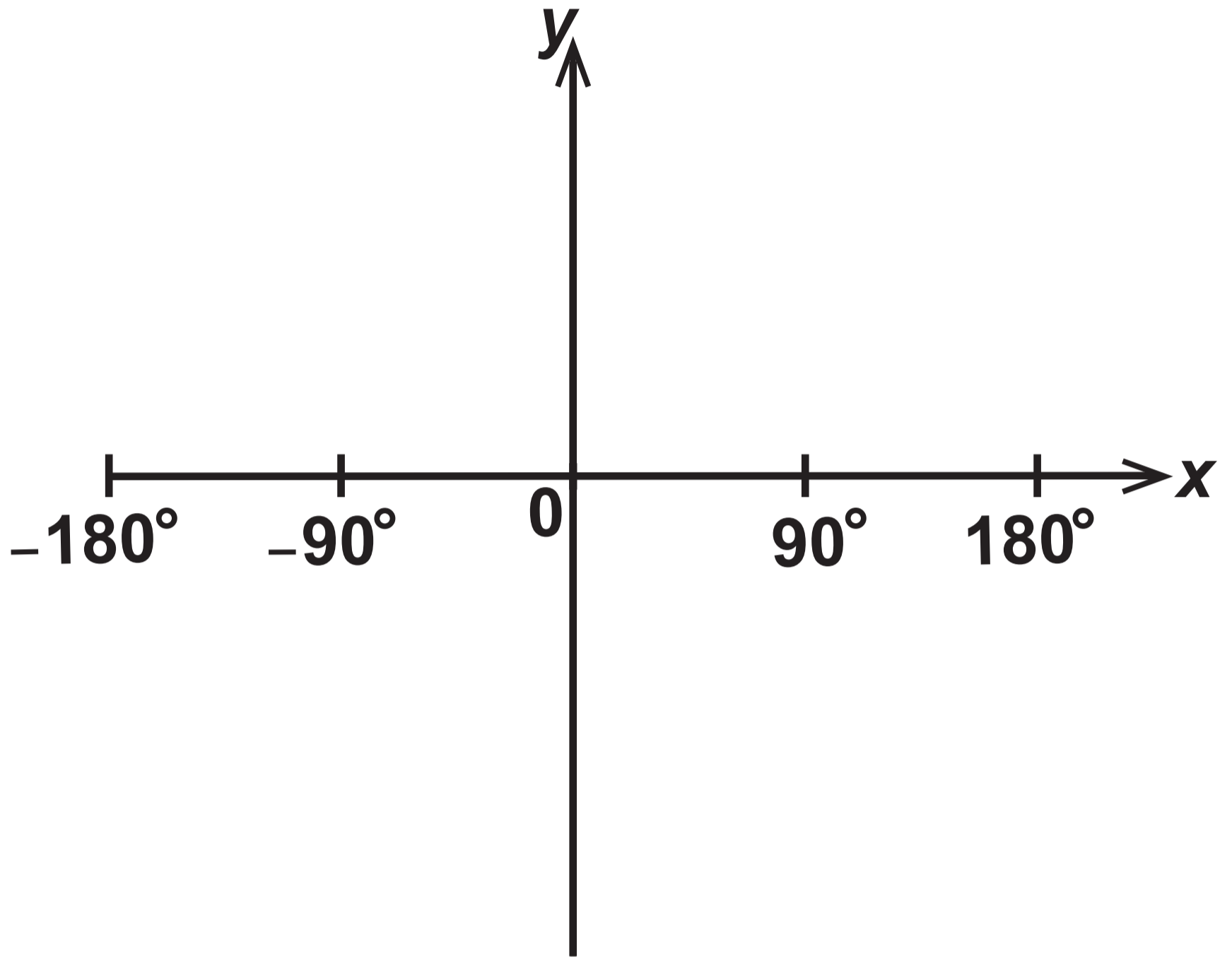

Question 18

Diagram NOT drawn to scale

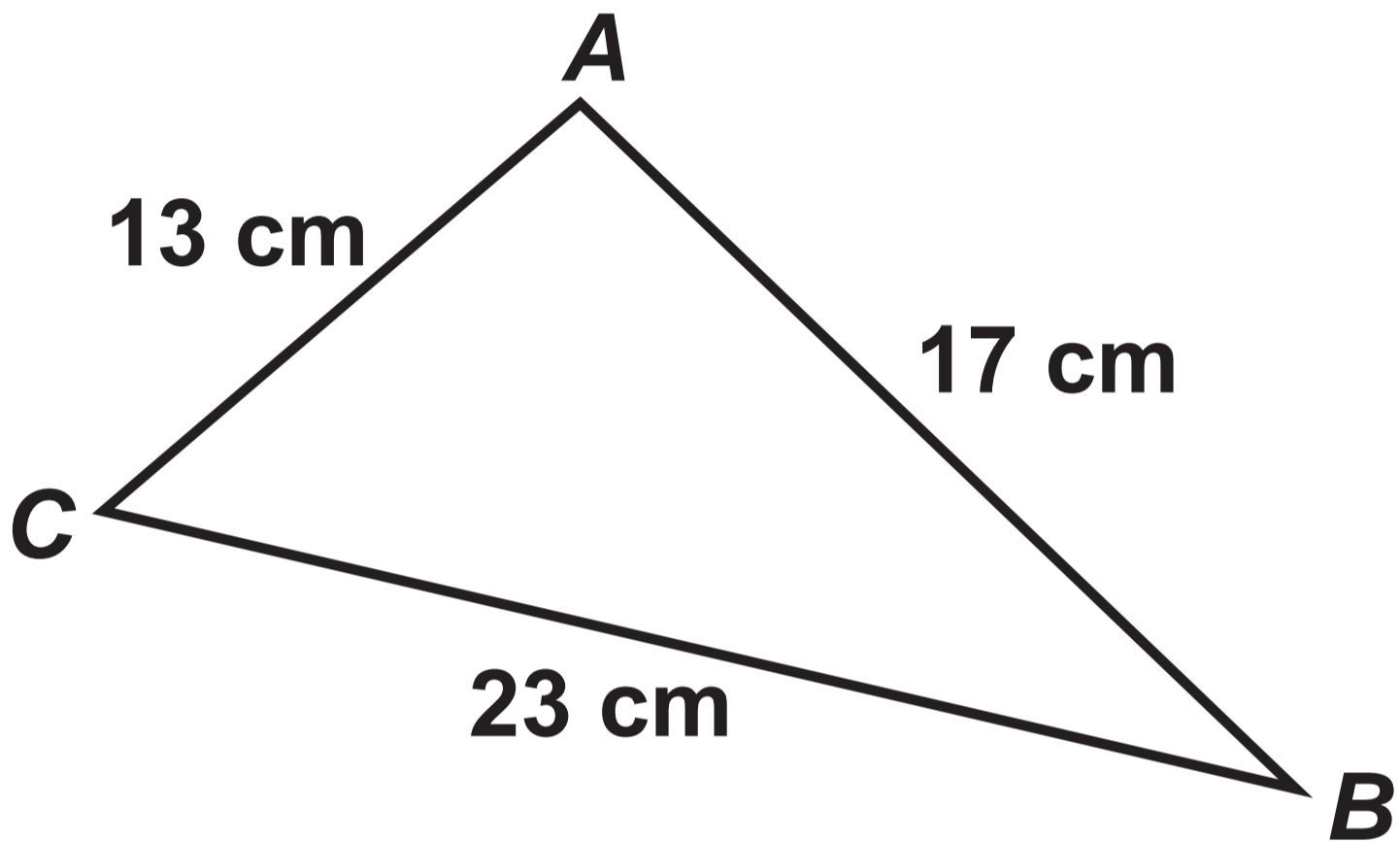

GCSE

3300U60-1



MATHEMATICS

UNIT 2: CALCULATOR – ALLOWED

HIGHER TIER

THURSDAY, 6 JUNE 2019 – MORNING

Spare Diagram Booklet

Surname:	
Other Names:	
Centre Number:	
Candidate Number:	0

Question 2

Diagram NOT drawn to scale

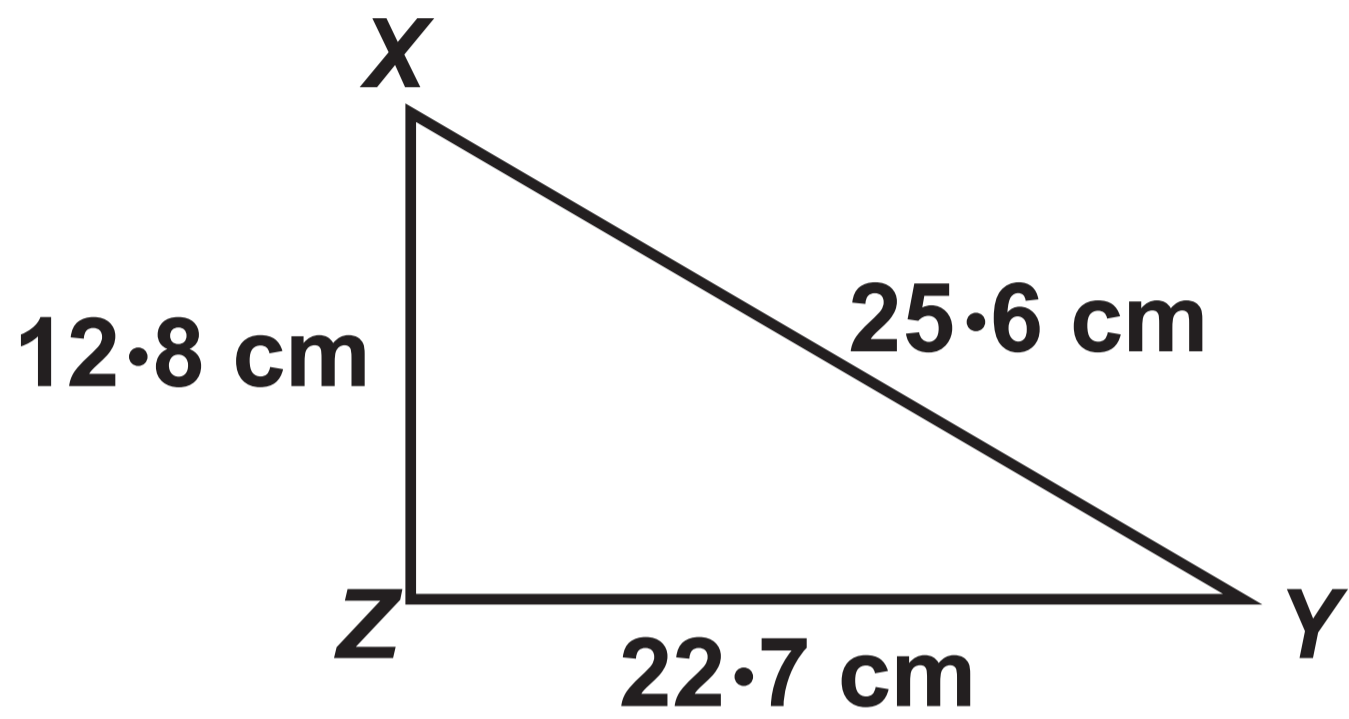

Question 3 (a)

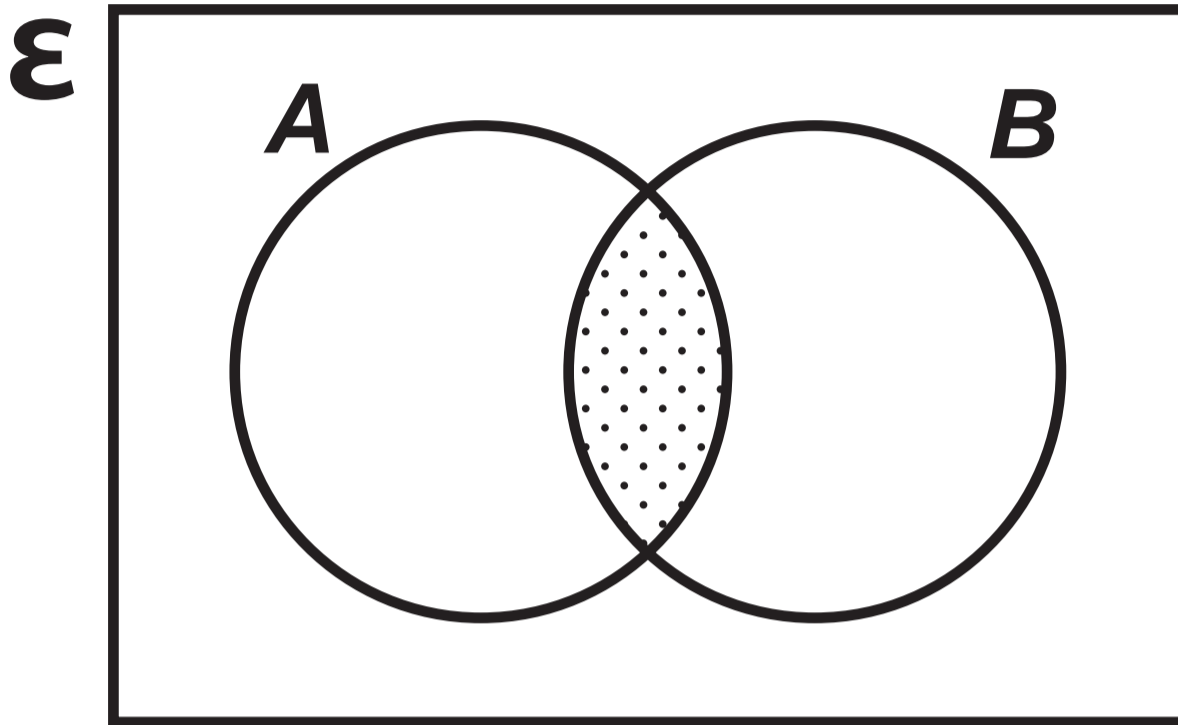

Question 3 (b)

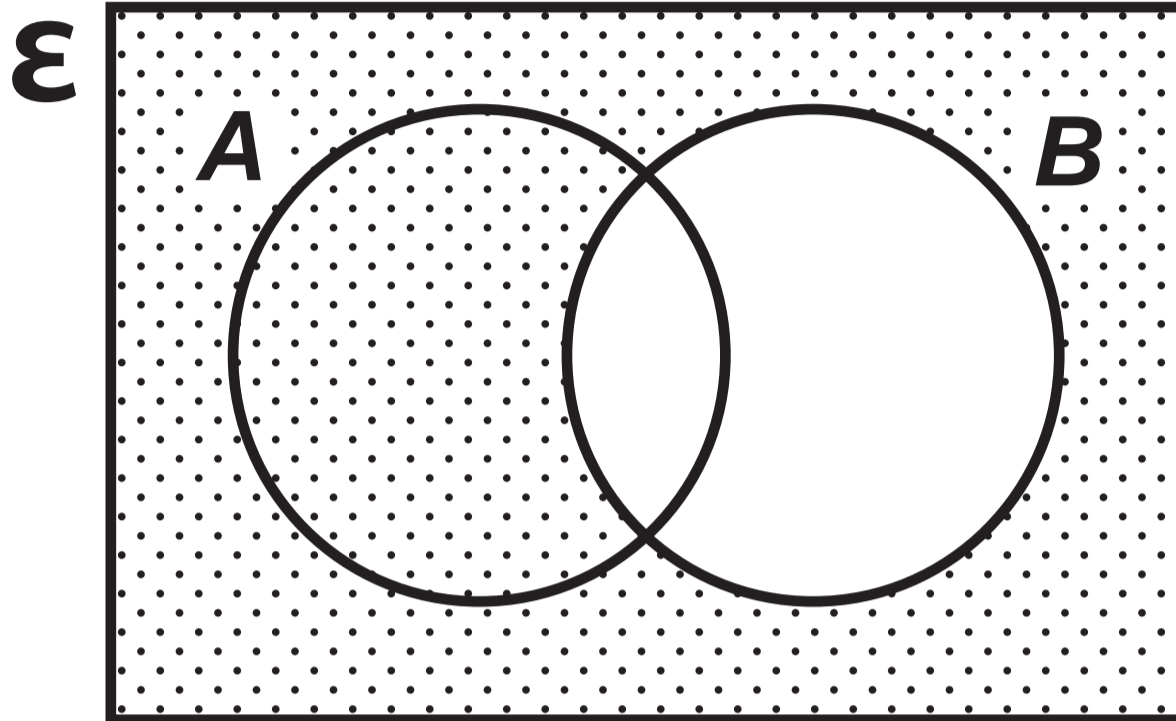

Question 5

Pie chart 1
128 female staff

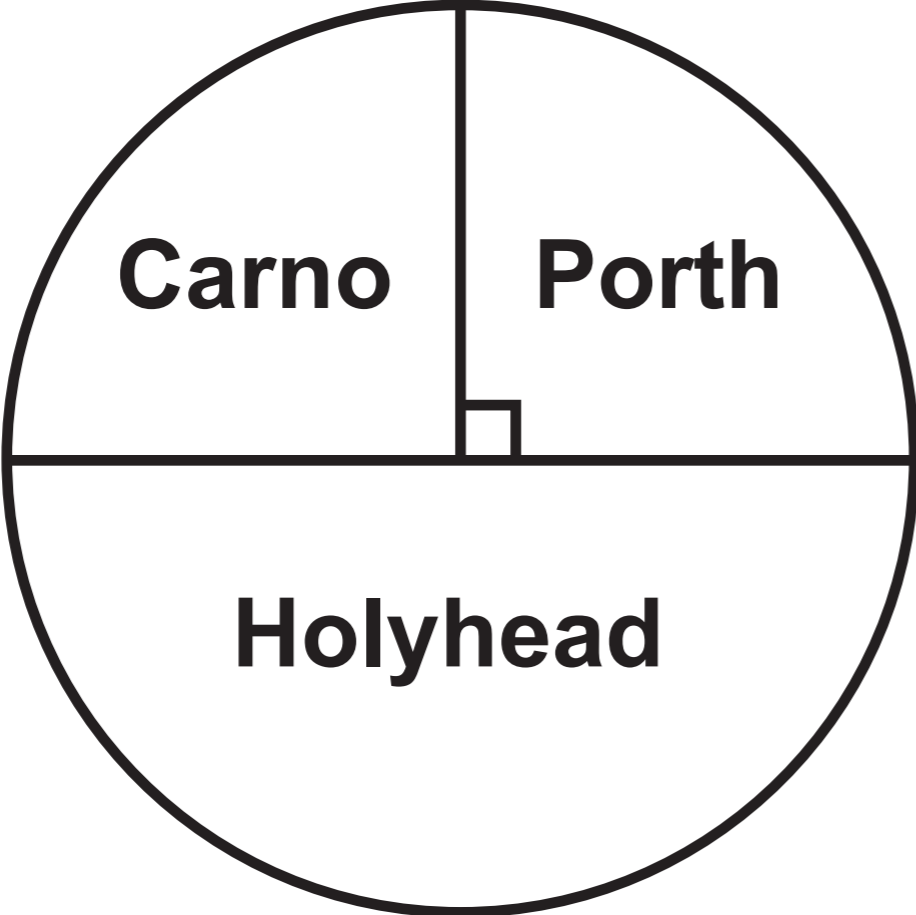

Pie chart 2
72 male staff

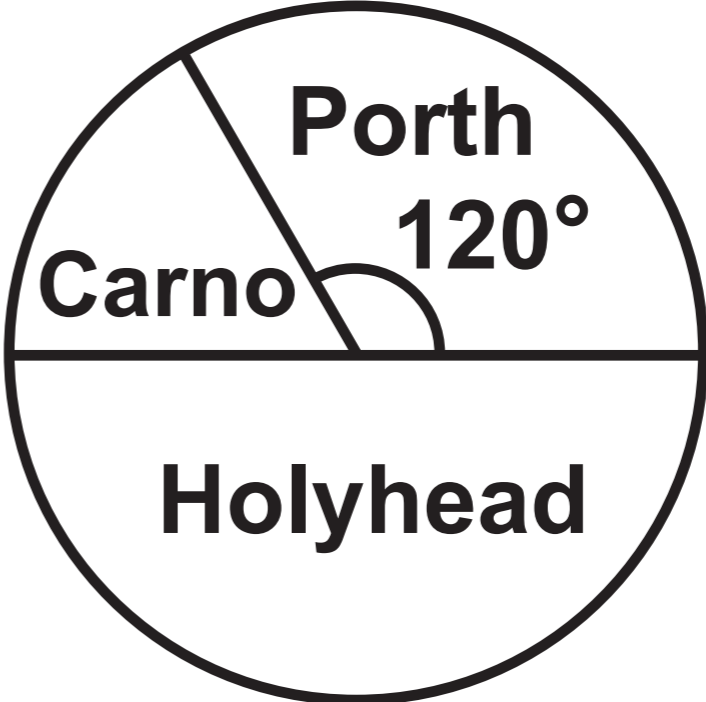

Question 6

Diagram NOT drawn to scale

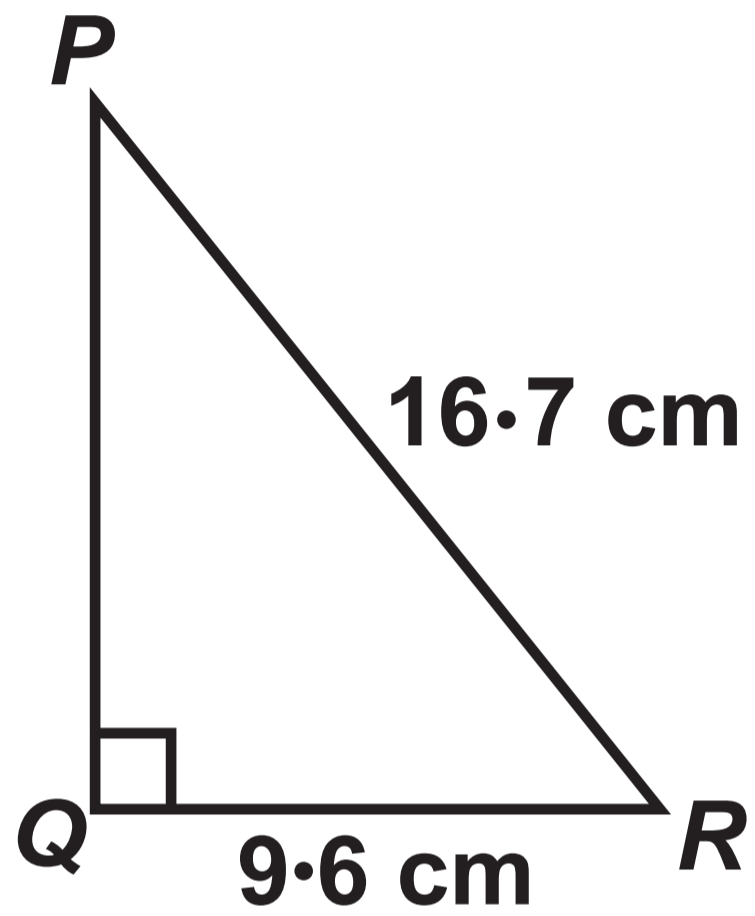

Question 10

Diagram NOT drawn to scale

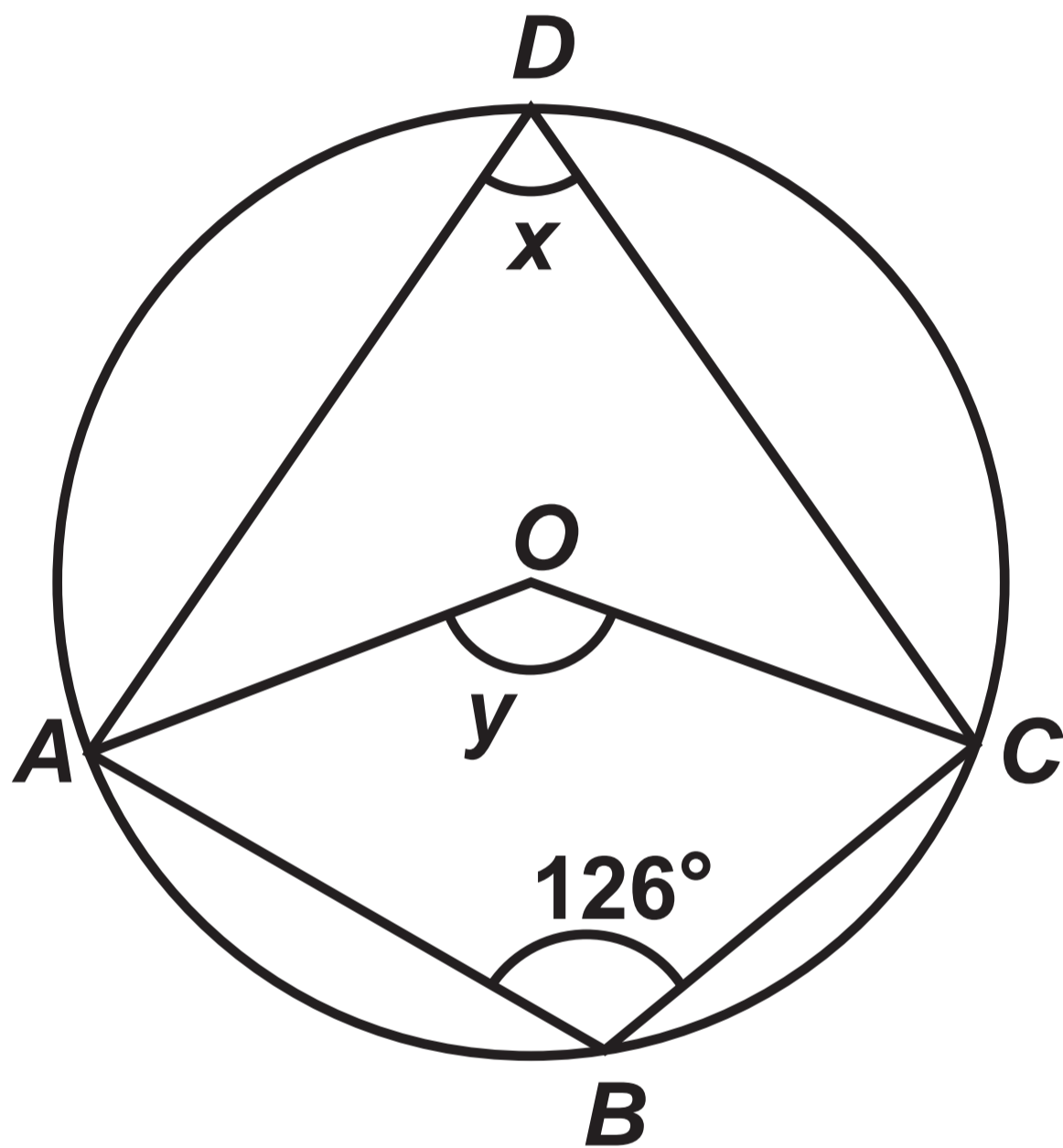

Question 11

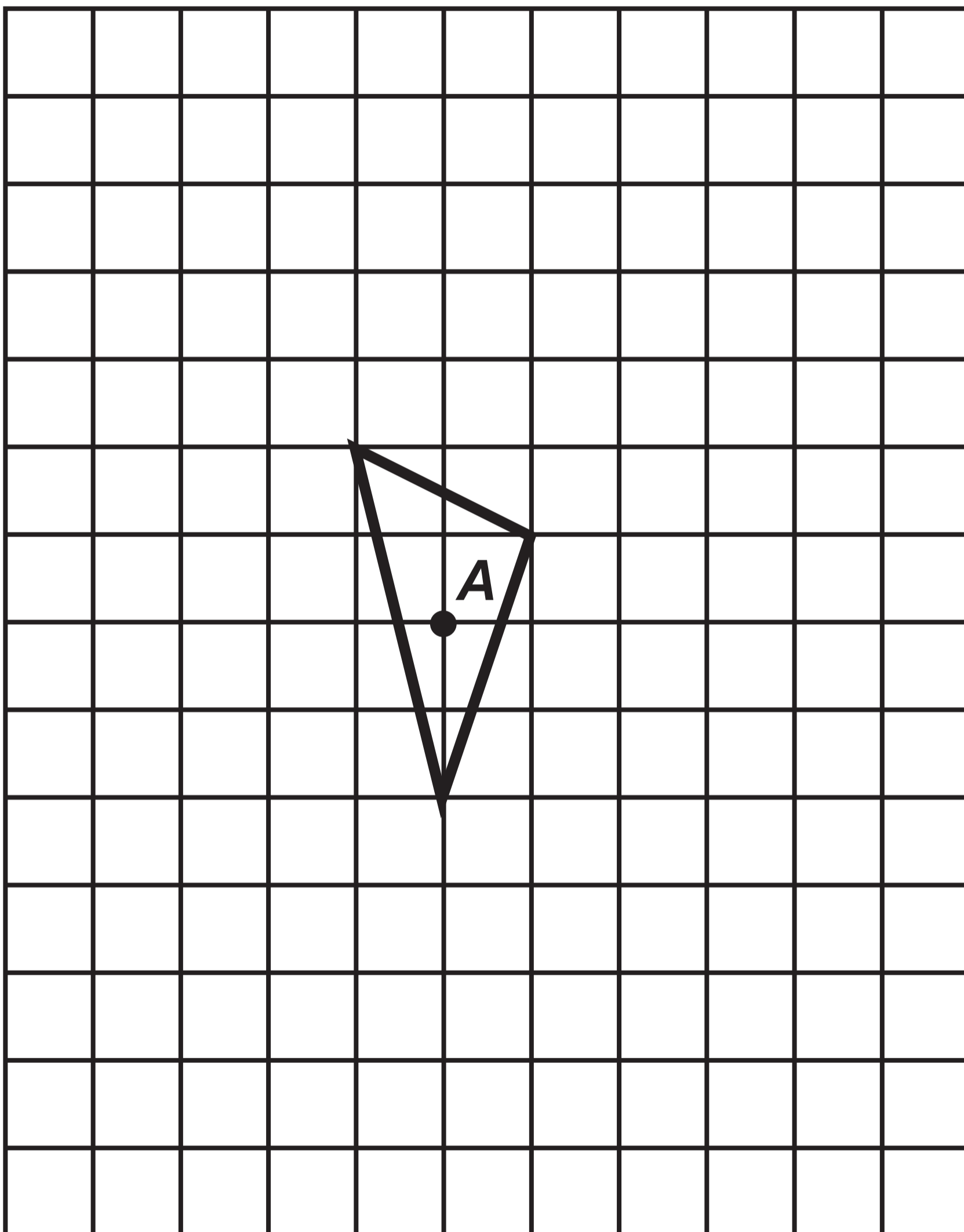

Question 14

Diagram NOT drawn to scale

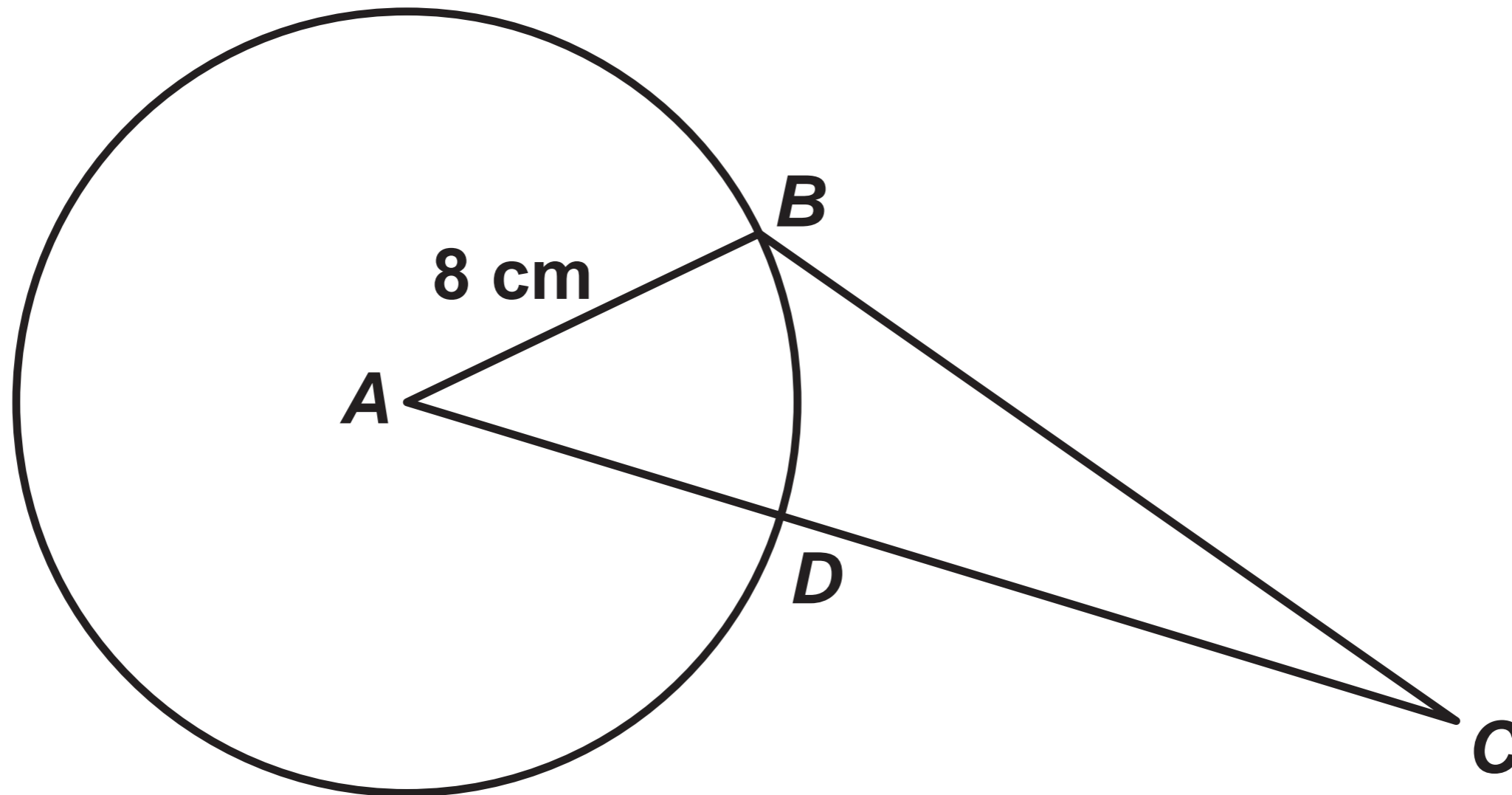

Question 15

Graph A

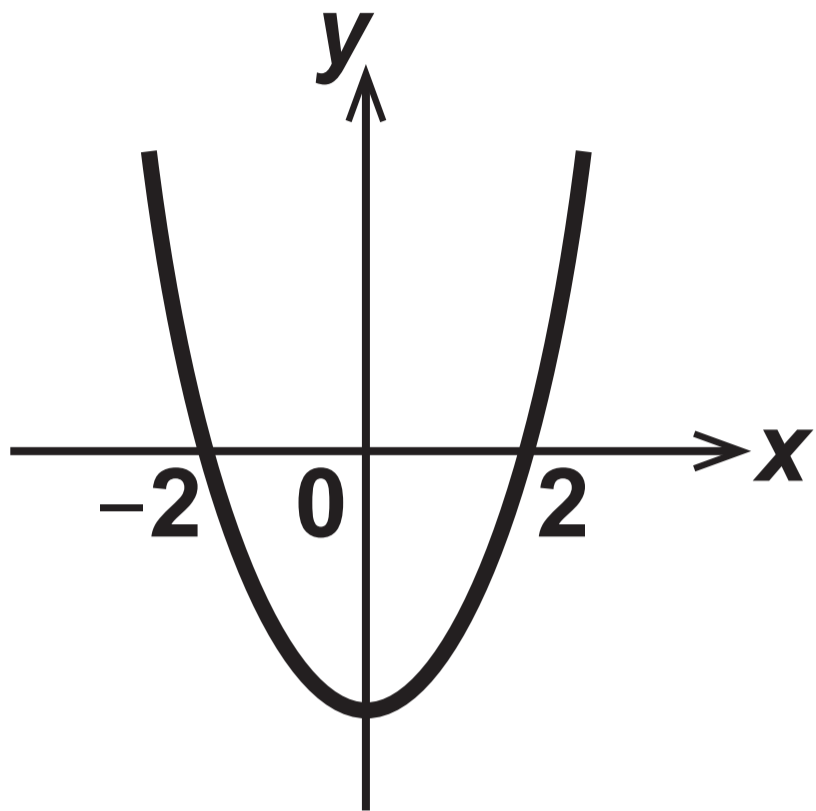

Graph B

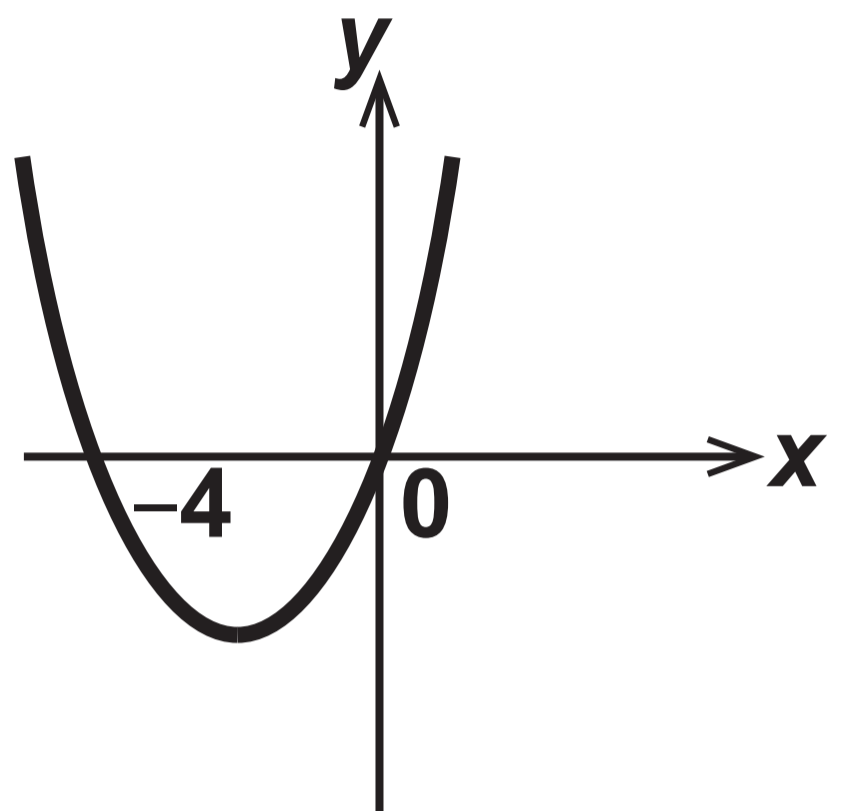

Graph C

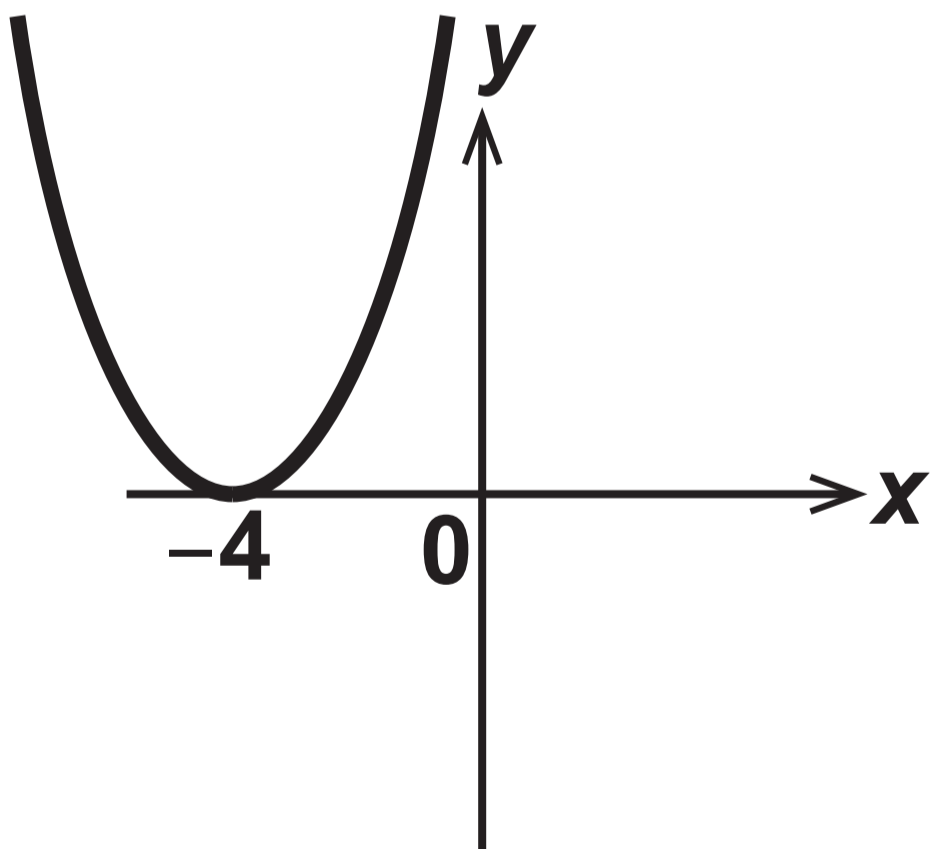

Graph D

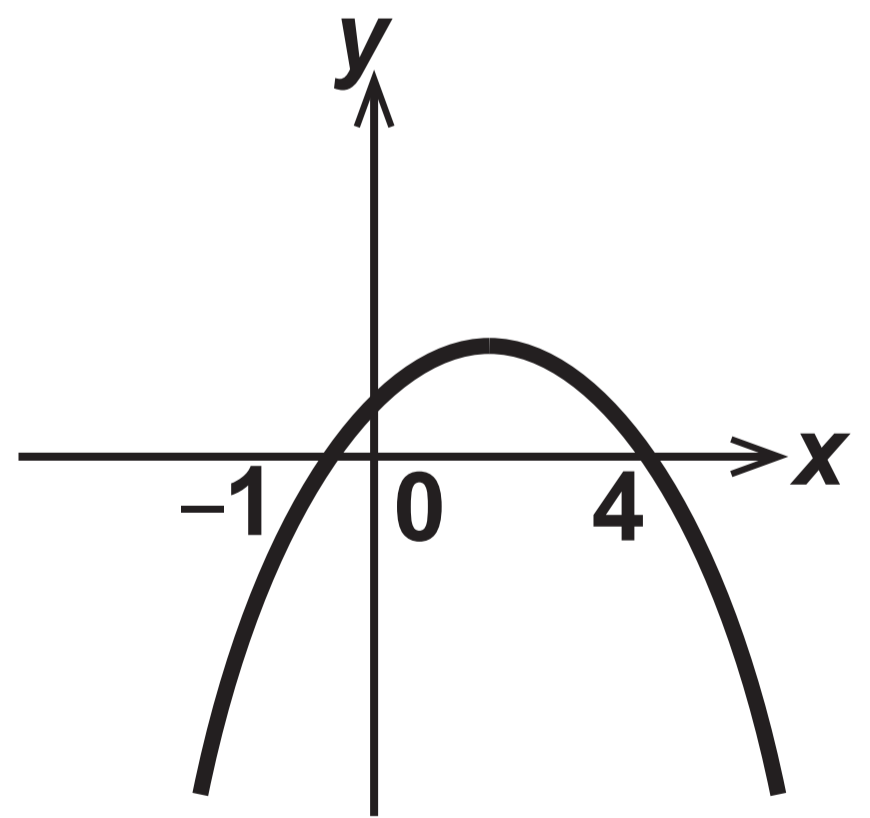

Question 15

EQUATIONS

1	$y = (x + 1)(x - 4)$
2	$y = (x - 4)^2$
3	$y = x(x + 4)$
4	$y = (x - 1)(x + 4)$
5	$y = (x - 2)(x + 2)$
6	$y = x(x - 4)$
7	$y = (x + 1)(4 - x)$
8	$y = (1 - x)(x + 4)$
9	$y = (x + 4)^2$

Question 16 (a)

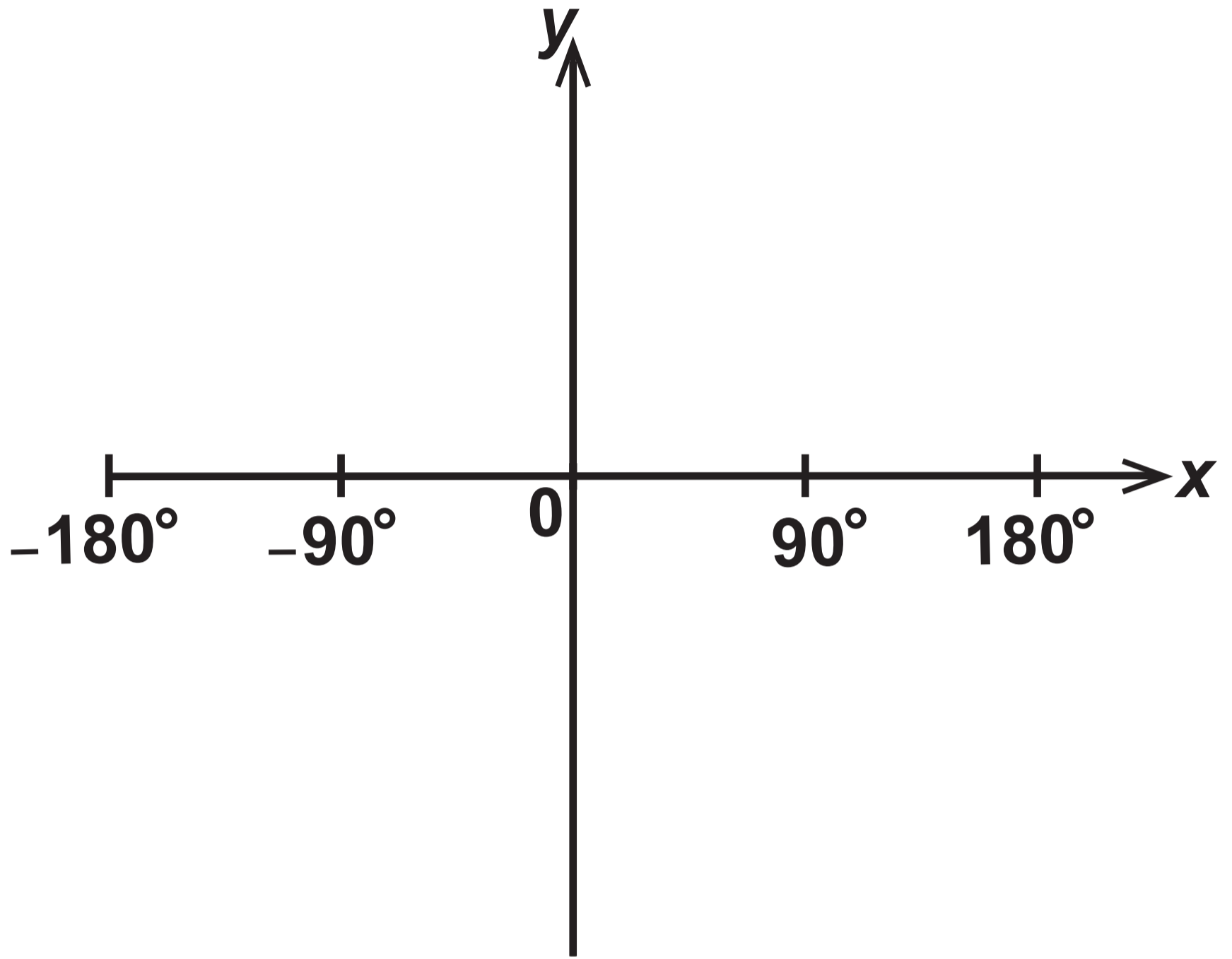

Question 18

Diagram NOT drawn to scale

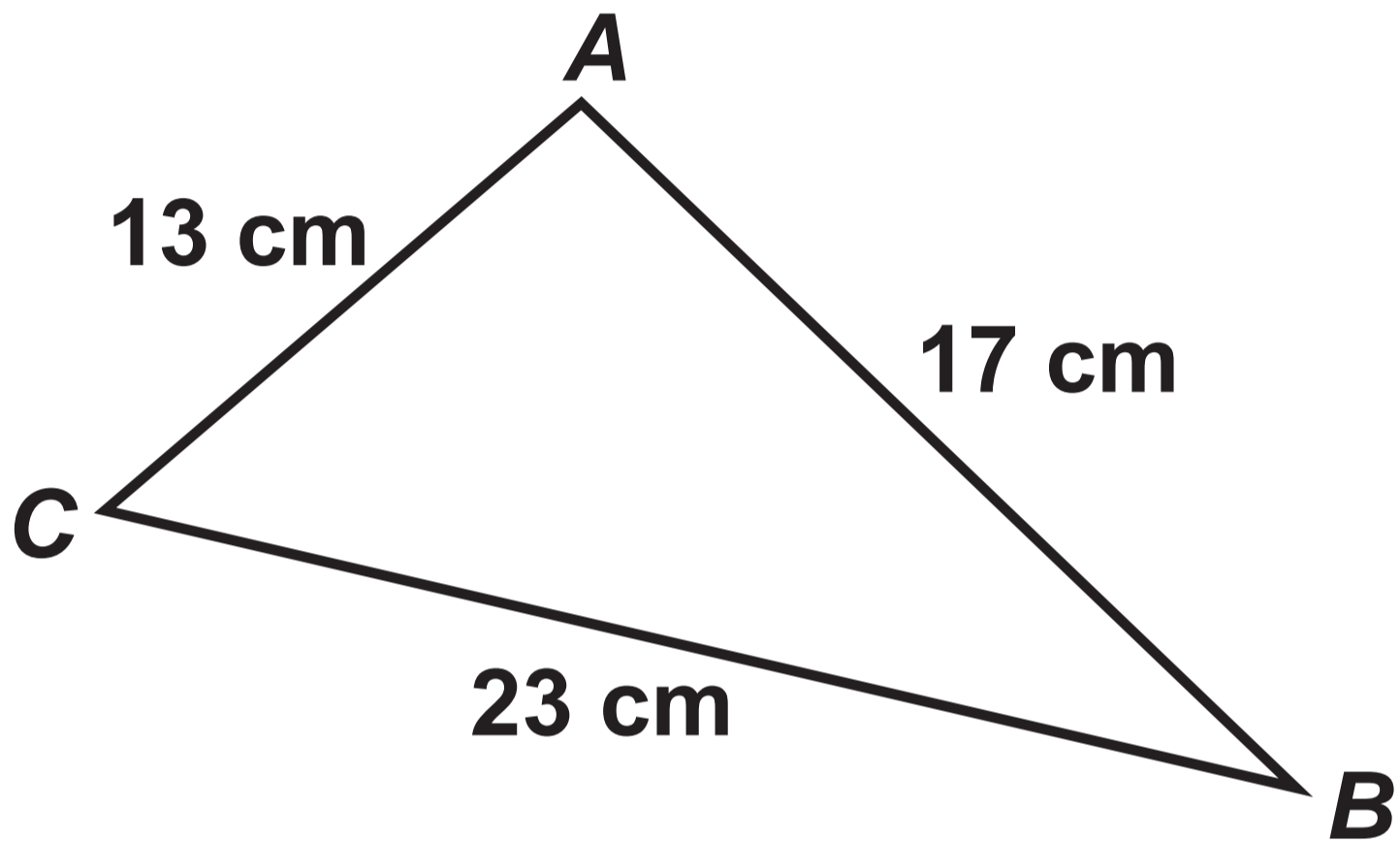

**GCSE
MATHEMATICS
and
NUMERACY**

**FORMULA LIST
HIGHER TIER
GCSE**

You must not write on these formula pages.

Anything you write on these formula pages will gain NO credit.

Formula List – Higher Tier

Area of trapezium $= \frac{1}{2} (a + b) h$

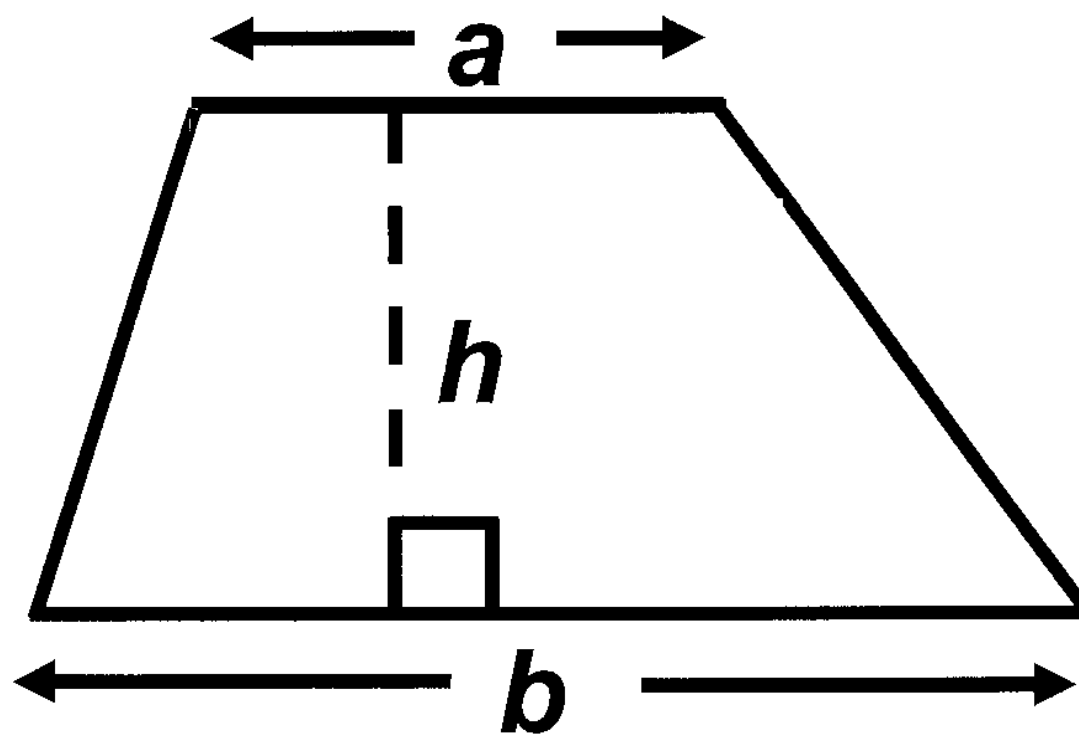

Volume of prism =
area of cross – section \times length

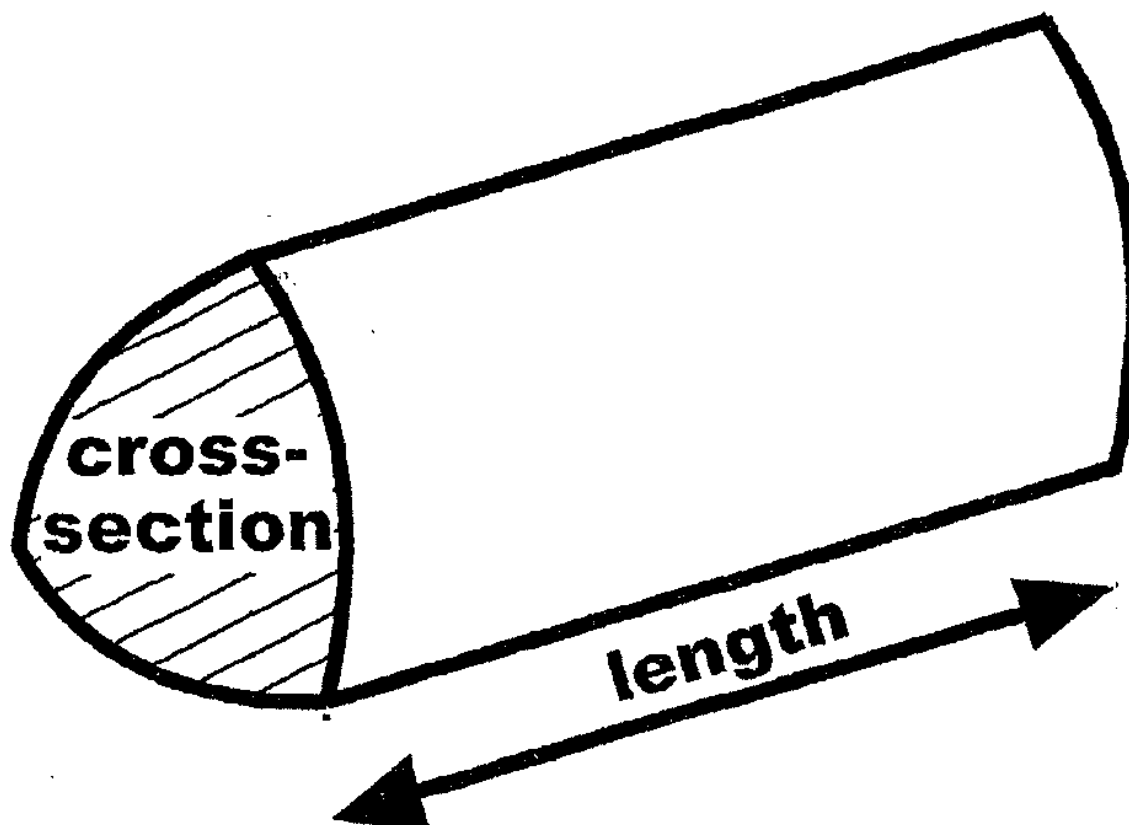

Volume of sphere = $\frac{4}{3}\pi r^3$

Surface area of sphere = $4\pi r^2$

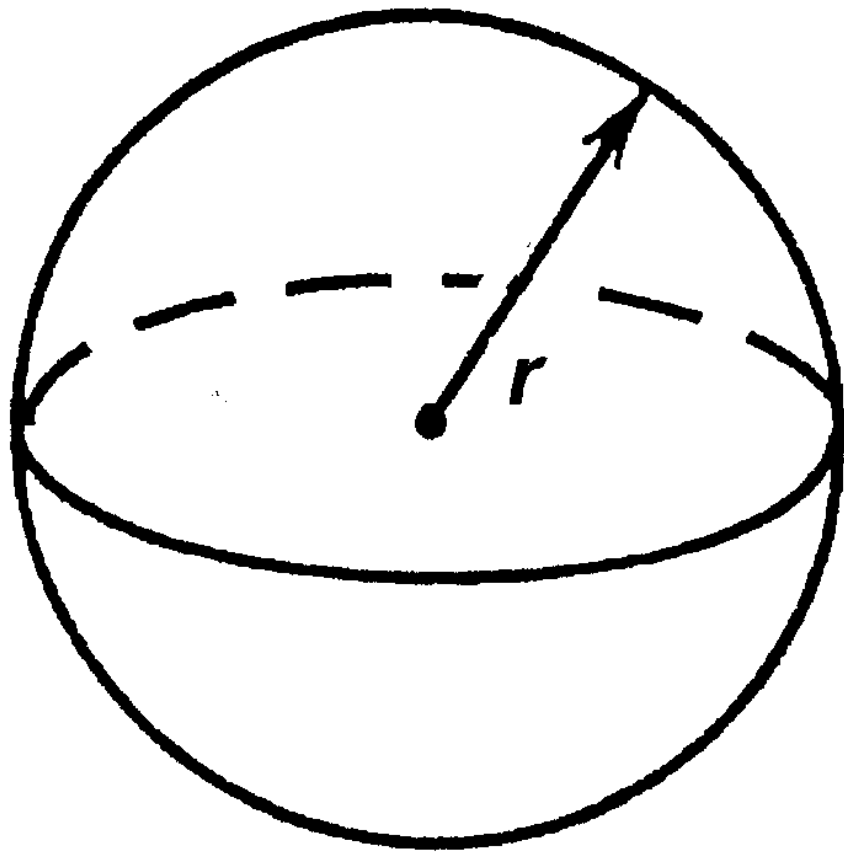

Volume of cone = $\frac{1}{3}\pi r^2 h$

Curved surface area of cone = $\pi r l$

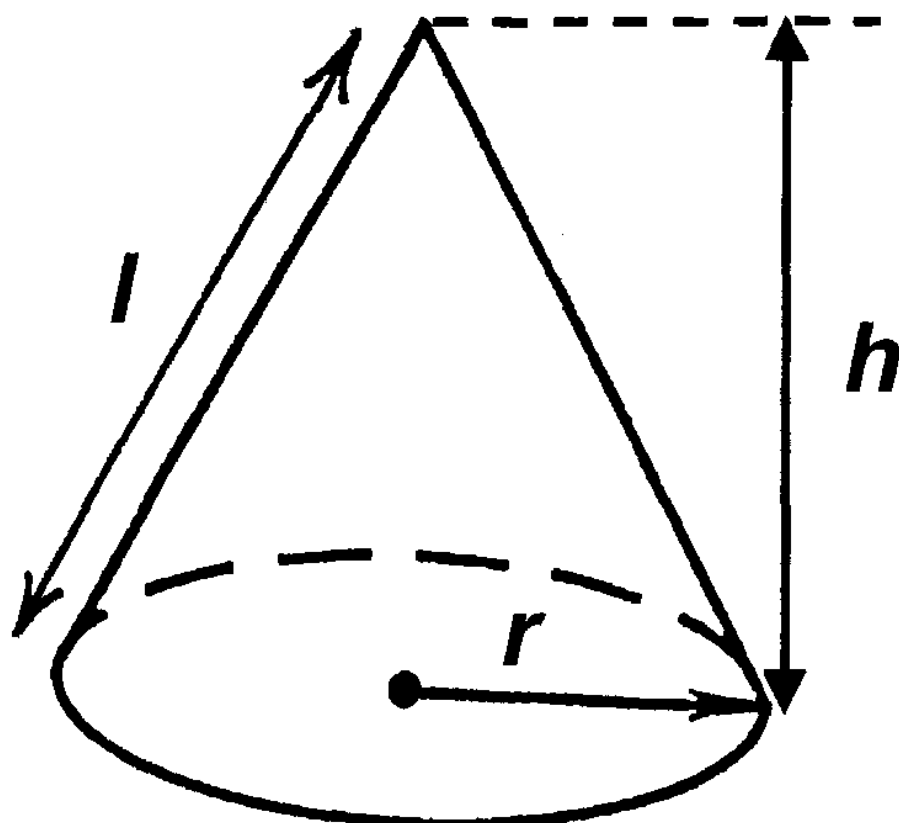

In any triangle ABC

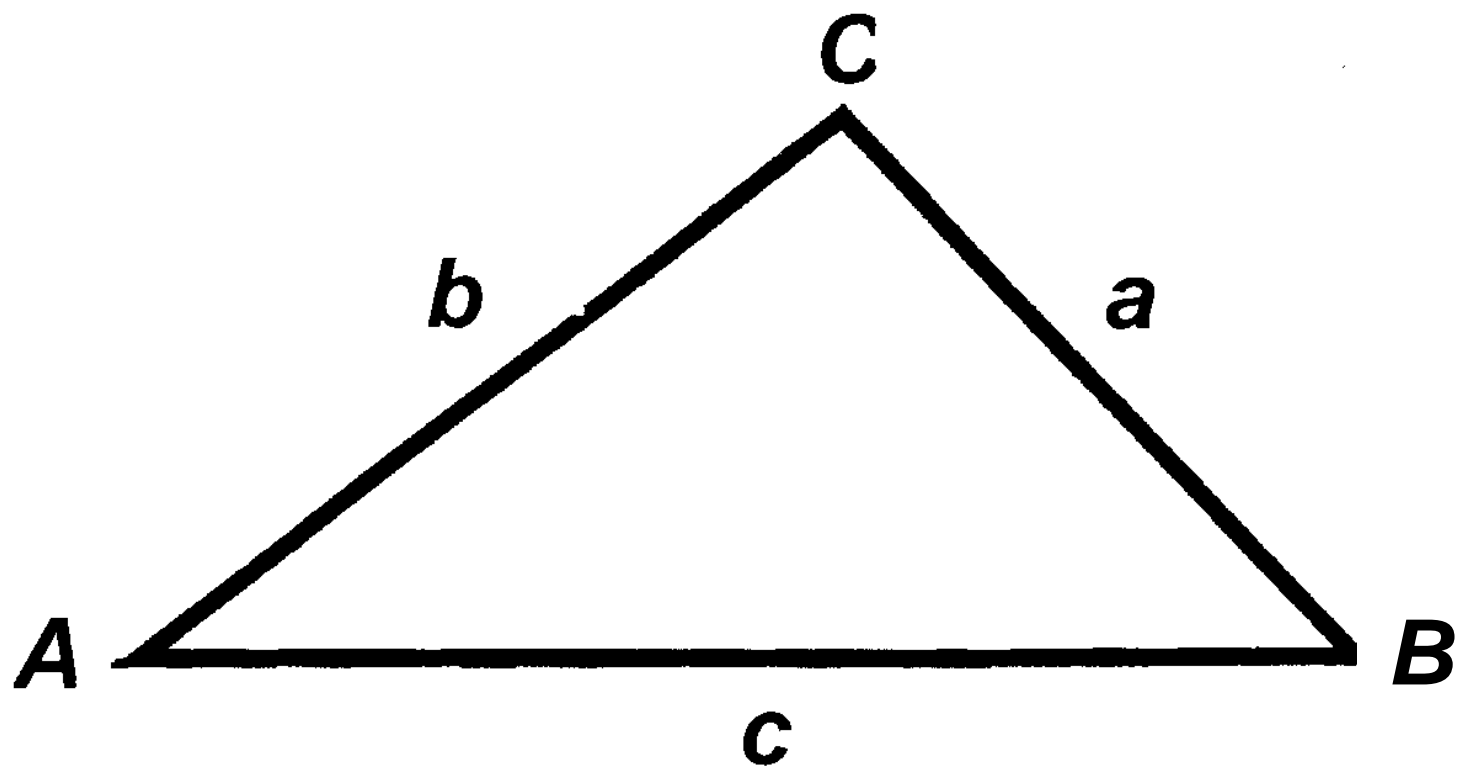

Sine Rule $\frac{a}{\sin A} = \frac{b}{\sin B} = \frac{c}{\sin C}$

Cosine Rule $a^2 = b^2 + c^2 - 2bc \cos A$

Area of triangle $= \frac{1}{2} ab \sin C$

The Quadratic Equation

The solutions of $ax^2 + bx + c = 0$

where $a \neq 0$, are given by

$$x = \frac{-b \pm \sqrt{b^2 - 4ac}}{2a}$$

Annual Equivalent Rate (AER)

AER, as a decimal, is calculated using the formula $\left(1 + \frac{i}{n}\right)^n - 1$, where i is the nominal interest rate per annum as a decimal and n is the number of compounding periods per annum.