



**Surname** \_\_\_\_\_

**Forename(s)** \_\_\_\_\_

**Centre Number** \_\_\_\_\_

**Candidate Number** \_\_\_\_\_

**Candidate Signature** \_\_\_\_\_

**I declare this is my own work.**

**A-level**

**PHYSICS**

**Paper 3**

**Section B    Electronics**

**7408/3BE**

**Monday 17 June 2024**

**Morning**

**At the top of the page, write your surname and forename(s), your centre number, your candidate number and add your signature.**

**[Turn over]**



**Time allowed:** The total time for both sections of this paper is 2 hours. You are advised to spend approximately 50 minutes on this section.

### **MATERIALS**

**For this paper you must have:**

- a pencil and a ruler
- a scientific calculator
- a Data and Formulae Booklet
- a protractor.

### **INSTRUCTIONS**

- Use black ink or black ball-point pen.
- Answer ALL questions.
- You must answer the questions in the spaces provided. Do not write on blank pages.
- If you need extra space for your answer(s), use the lined pages at the end of this book. Write the question number against your answer(s).
- Do all rough work in this book. Cross through any work you do not want to be marked.
- Show all your working.



## **INFORMATION**

- **The marks for questions are shown in brackets.**
- **The maximum mark for this paper is 35.**
- **You are expected to use a scientific calculator where appropriate.**
- **A Data and Formulae Booklet is provided as a loose insert.**

**DO NOT TURN OVER UNTIL TOLD TO DO SO**





## SECTION B

Answer ALL questions in this section.

0	1
---	---

A toy manufacturer is designing a two-tone siren for use in small battery-operated cars.

FIGURE 1, on page 6, shows design Option 1.

Option 1 uses three separate signal generators feeding into a logic sub-system. The signal generators produce logic-compatible 9 V square waves of frequencies 1024 Hz, 1 Hz and 512 Hz.

**BLANK PAGE**



**[Turn over]**





---

---

---

---

0 1 . 2

**Write the Boolean algebra expression for output Q in terms of the inputs A, B and C.  
Use only the logic operations shown in FIGURE 1. [2 marks]**

**Q =** \_\_\_\_\_

**[Turn over]**

**01.3**

Option 1 is tested by replacing the 1 Hz signal generator with a manual input.

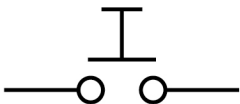
The manual input is provided by the combination of a push-to-make switch and a 10 k $\Omega$  resistor.

The combination produces the following voltages at its output:

- 0 V when the switch is not pressed
- 9 V when the switch is pressed.

FIGURE 2 shows the symbol for the push-to-make switch.

FIGURE 2

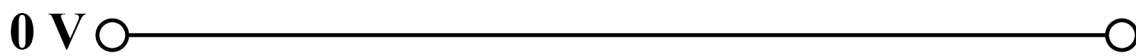
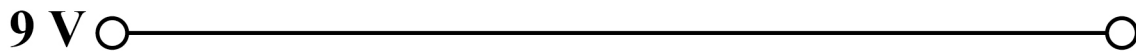


Complete FIGURE 3 to show how this switch and the  $10\text{ k}\Omega$  resistor are connected.

Label the output  $V_{\text{out}}$ .

You do not need to add details taken from FIGURE 1, on page 6. [1 mark]

FIGURE 3



[Turn over]



**BLANK PAGE**

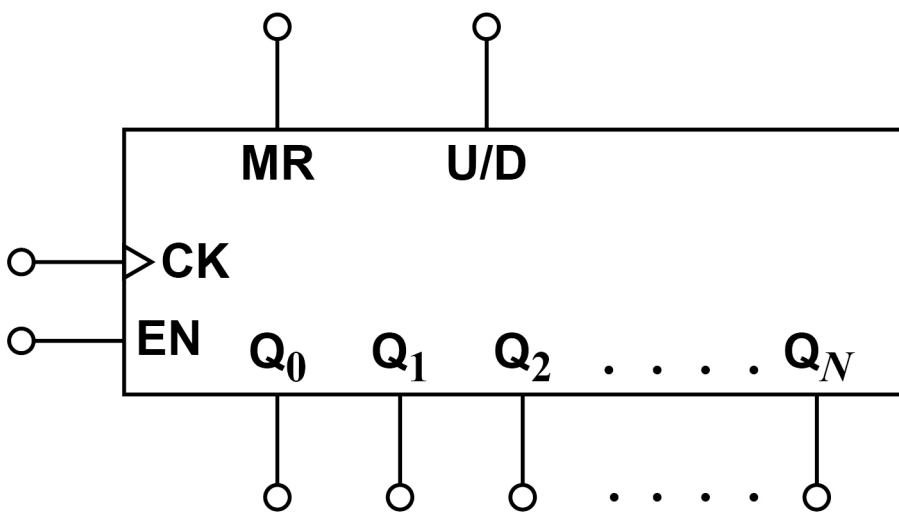


01.4

FIGURE 4 shows a generalised layout of an integrated circuit (IC) for an  $N$ -bit binary counter.

$Q_0$  is the output that provides the least significant bit.

FIGURE 4



A signal generator feeds a square wave of frequency 1024 Hz into the clock of the IC.

The  $N$ -bit binary counter generates the 512 Hz signal and the 1 Hz signal from separate outputs.

Deduce which of the outputs  $Q_0$  to  $Q_N$  will provide the 1 Hz signal. [1 mark]

---



---

[Turn over]



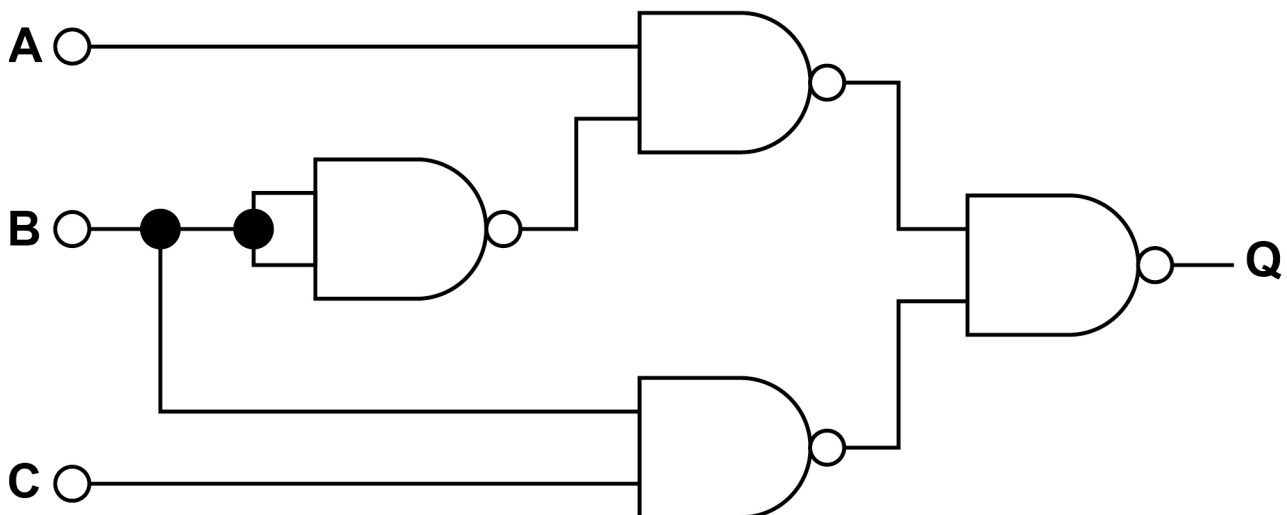
0	1	.	5
---	---	---	---

To make the two-tone siren, the manufacturer decides to use a new design, Option 2.

Option 2 contains:

- one 1024 Hz signal generator
- one  $N$ -bit binary counter
- a new logic sub-system as shown in FIGURE 5.

FIGURE 5



Assume that:

- each TYPE of logic gate has its own dedicated IC chip
- each separate signal generator is based upon its own IC chip.





0	2
---	---

The short message service (SMS) on a mobile phone can send a maximum of 160 characters per message. Each character is represented by its own seven-bit binary code as it is converted to digital data.

0	2	.	1
---	---	---	---

The mobile phone transmits digital data at a rate of 8 kilobytes per second ( $\text{kB s}^{-1}$ ) when using the SMS function.

Determine the minimum time required to send 160 characters. [2 marks]

time = \_\_\_\_\_ s



**Electrical noise can affect communication systems.**

**0 2 . 2**

**Describe ONE origin of electrical noise in a communication system. [1 mark]**

---

---

---

---

**[Turn over]**





**BLANK PAGE**

**[Turn over]**



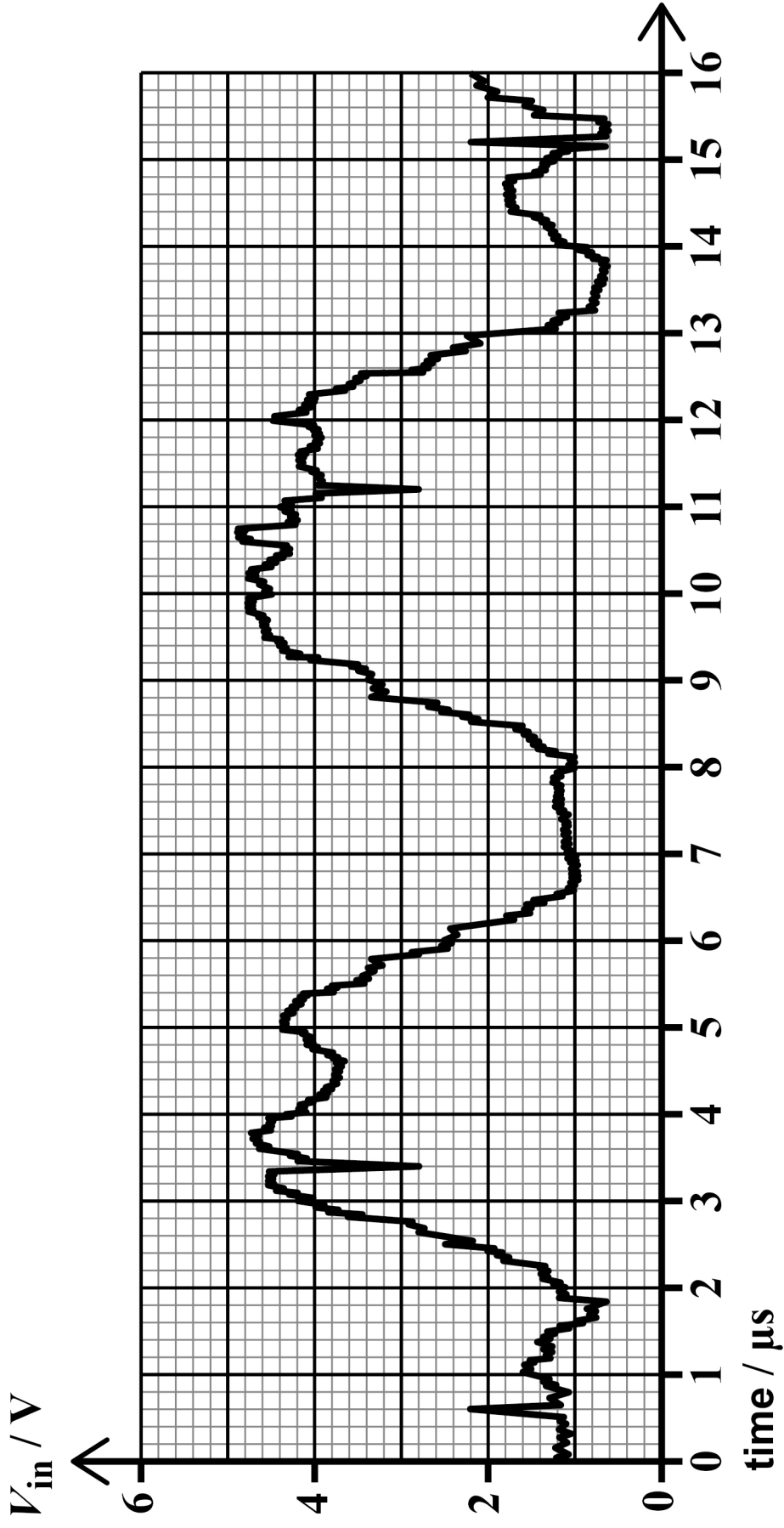


**FIGURE 6, on the opposite page, shows a noisy digital signal  $V_{in}$  which is applied to a circuit.**

**The circuit output  $V_{out}$  switches to:**

- 5 V when the input voltage  $V_{in}$  falls below 1.8 V**
- 0 V when the input voltage  $V_{in}$  rises above 3.2 V.**

FIGURE 6



[Turn over]

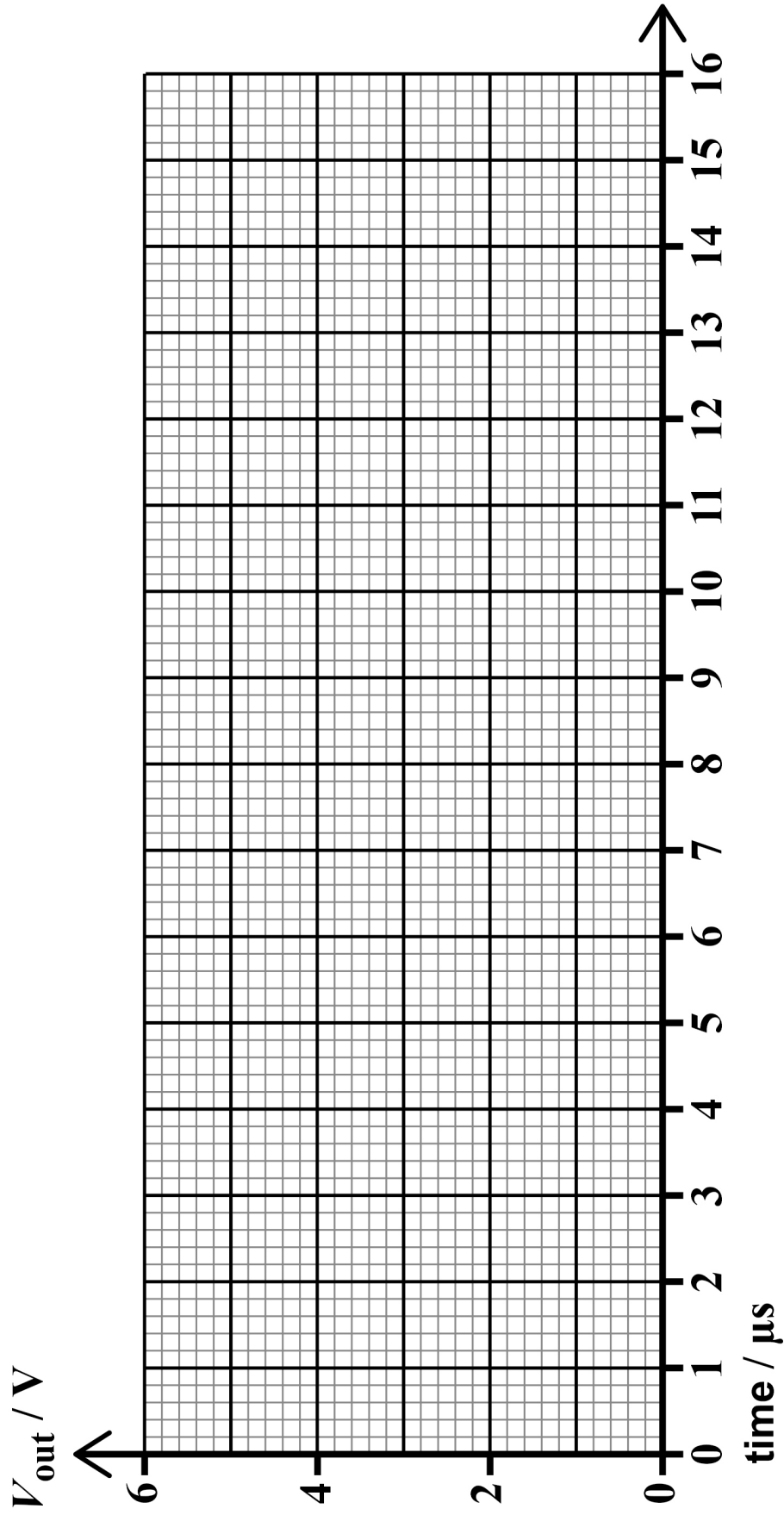


**BLANK PAGE**





**FIGURE 7**



.

Draw, on **FIGURE 7**, the output signal  $V_{\text{out}}$  from the circuit.

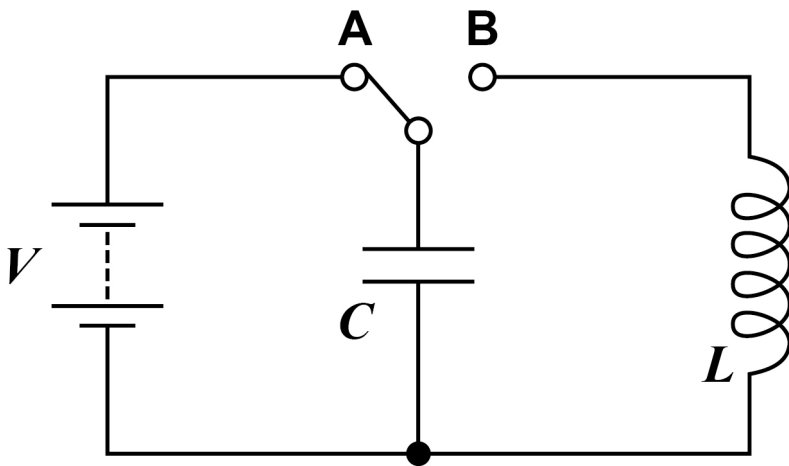
Assume that  $V_{\text{out}}$  is initially at 5 V. [2 marks]

[Turn over]

03

FIGURE 8 shows an  $LC$  circuit that produces electrical oscillations when the switch is moved from position A to position B.

FIGURE 8



03.1

Which quantity in the  $LC$  circuit is analogous to the mass in a mass–spring system?

Tick (✓) ONE box. [1 mark]

$C$

$\frac{1}{C}$

$L$

$\frac{1}{L}$

[Turn over]



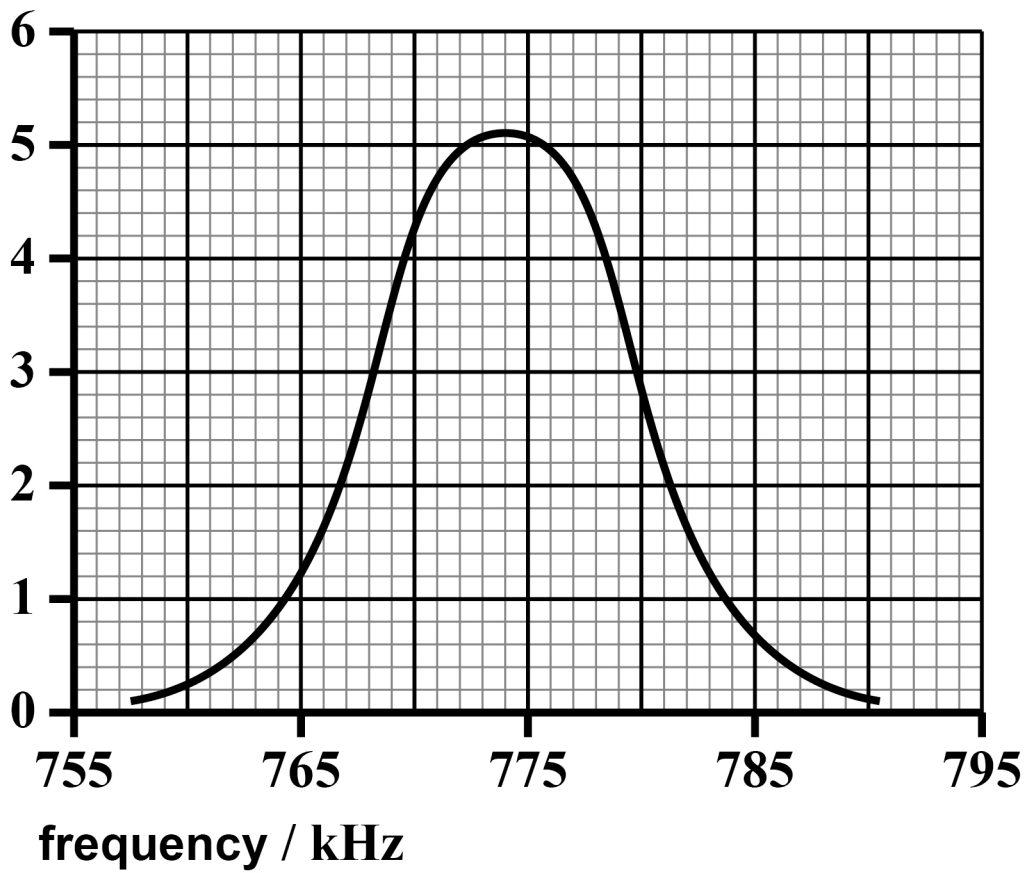
03.2

A radio receiver uses a parallel  $LC$  tuned circuit to select a radio station.

FIGURE 9 shows the response of the tuned circuit.

FIGURE 9

output  
voltage  
/ mV



Calculate the quality factor  $Q$  of the tuned circuit.  
[3 marks]

$Q =$  \_\_\_\_\_

[Turn over]



Another radio receiver is used to detect frequency-modulated (FM) radio waves.

FIGURE 10, on the opposite page, shows the variation of amplitude with time for a carrier wave and an information signal.

03.3

Sketch, on FIGURE 10, the graph that represents the frequency-modulated (FM) signal. [2 marks]

03.4

An audio signal is transmitted on an FM music station. The transmission has a bandwidth of 186 kHz. The carrier wave has a maximum frequency deviation of 75 kHz.

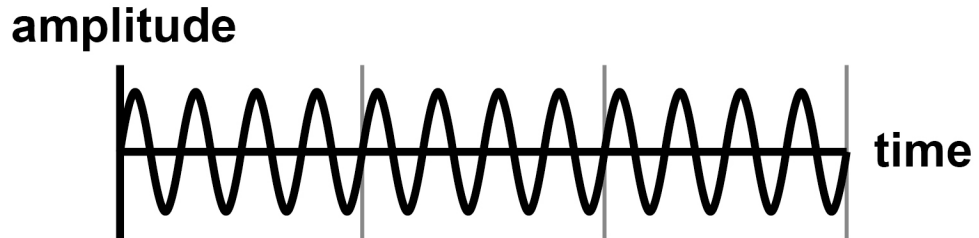
Calculate the maximum frequency in the information signal. [1 mark]

maximum frequency = \_\_\_\_\_ kHz

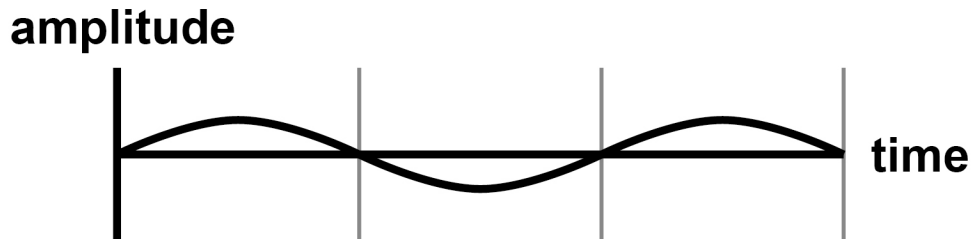


FIGURE 10

## CARRIER WAVE



## INFORMATION SIGNAL



## FREQUENCY-MODULATED SIGNAL



[Turn over]

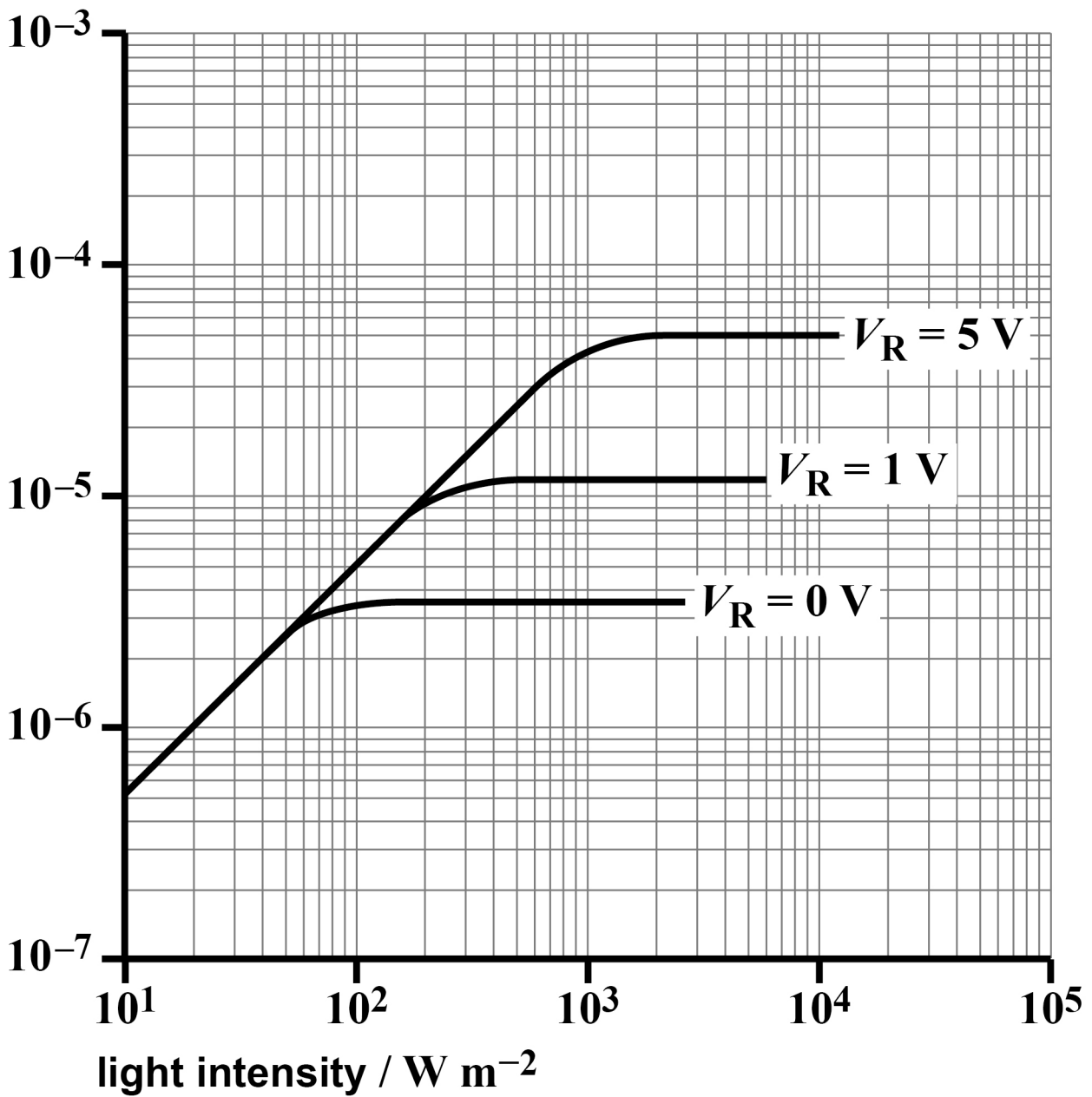


04.1

FIGURE 11 shows the response of a photodiode for different values of reverse-bias voltage  $V_R$ .

FIGURE 11

photocurrent / A



The photodiode is used as the input for a light-intensity meter.

The light intensity changes from  $100 \text{ W m}^{-2}$  to  $400 \text{ W m}^{-2}$ .

Explain which value of  $V_R$  in FIGURE 11 should be used for this application.

Go on to deduce the change in photocurrent for this change in light intensity. [2 marks]

---

---

---

---

change in photocurrent = \_\_\_\_\_ A

[Turn over]



**BLANK PAGE**





0	4	.	3
---	---	---	---

The particle detector produces an analogue signal that is the input voltage  $V_{in}$  to an amplifier circuit.

$V_{in}$  is amplified by a factor of +10

Draw, on FIGURE 12, on the opposite page, a circuit that uses a single operational amplifier to produce an amplification of +10

Use resistors with resistance values in the range 10 k $\Omega$  to 1 M $\Omega$  in the circuit.

On your diagram you should label:

- the value of the resistors
- the output of the circuit as  $V_{out}$ .

Do NOT show the power supplies for the operational amplifier. [3 marks]



## FIGURE 12

 $V_{in}$  ○ —

0 V ○ ————— ○

[Turn over]

7



0	5
---	---

**Several telephone conversations need to be transmitted simultaneously between two locations.**

**Describe the process that allows these conversations to be carried by the same optical fibre.**

**In your answer you should explain:**

- **the importance of the sampling rate in the analogue-to-digital conversion**
- **the effect of resolution in this conversion**
- **the technique that is used to enable several conversations to be transmitted simultaneously.**

**You may use diagrams to help with your explanation.  
[6 marks]**



---

---

---

**[Turn over]**









---

---

---

---

---

---

---

---

---

---

**END OF QUESTIONS**

6







**BLANK PAGE**

For Examiner's Use	
Question	Mark
1	
2	
3	
4	
5	
<b>TOTAL</b>	

**Copyright information**

For confidentiality purposes, all acknowledgements of third-party copyright material are published in a separate booklet. This booklet is published after each live examination series and is available for free download from [www.aqa.org.uk](http://www.aqa.org.uk)

Permission to reproduce all copyright material has been applied for. In some cases, efforts to contact copyright-holders may have been unsuccessful and AQA will be happy to rectify any omissions of acknowledgements. If you have any queries please contact the Copyright Team.

Copyright © 2024 AQA and its licensors. All rights reserved.

**WP/M/SB/Jun24/7408/3BE/V4**