



Please write clearly in block capitals.

Centre number

--	--	--	--	--

Candidate number

--	--	--	--	--

Surname

Forename(s)

Candidate signature

I declare this is my own work.

A-level MATHEMATICS

Pure

Perfectly Ramped Paper

June 2025

About this Paper

This paper has been **reordered** according to how students actually performed in the examination series. The questions appear in order of increasing difficulty, based on real student performance data.

- The **first question** was the **best-answered** question on the paper, and each subsequent question was progressively more challenging.
- For questions with multiple parts (e.g. parts a-c), the parts have been kept together to preserve the structure and context of the original question.
- A **weighted mean facility index** was used to determine the overall position of each multi-part question, giving greater influence to parts with higher mark values.
- The **question numbers in brackets** show the **position of each question in the original paper**, allowing teachers to see where it originally appeared.

These papers are designed to help teachers and students see how question difficulty progresses in practice and to provide insight into how students across the cohort performed on each part of the paper.

For Examiner's Use	
Question	Mark
1 (1.1)	
2 (2.1)	
3 (2.7)	
4 (1.5)	
5 (2.4)	
6 (3.4)	
7 (2.5)	
8 (1.7)	
9 (3.8)	
10 (1.4)	
11 (3.6)	
12 (1.6)	
13 (3.1)	
14 (2.2)	
15 (1.2)	
16 (3.3)	
17 (3.7)	
18 (3.2)	
19 (1.8)	
20 (2.6)	

For Examiner's Use	
Question	Mark
21 (2.8)	
22 (1.3)	
23 (1.11)	
24 (2.9)	
25 (3.5)	
26 (1.10)	
27 (1.13)	
28 (1.9)	
29 (1.14)	
30 (1.12)	
31 (3.10)	
32 (1.15)	
33 (2.10)	
34 (2.3)	
35 (1.17)	
36 (3.9)	
37 (1.16)	
38 (3.11)	
39 (3.12)	
TOTAL	

- 1
(1.1) The equation of a curve is given by $y = 3e^x$

Find an expression for $\frac{dy}{dx}$

Circle your answer.

$3e^{-x}$ $3e^1$ $3e^x$ $3xe^{x-1}$

[1 mark]

- 2
(2.1) Describe the single transformation which maps the curve with the equation $y = \ln x$ onto the curve with the equation $y = 2\ln x$

Tick (✓) **one** box.

Stretch, scale factor 2, parallel to the y -axis

Stretch, scale factor $\frac{1}{2}$, parallel to the x -axis

Translation $\begin{bmatrix} 2 \\ 0 \end{bmatrix}$

Translation $\begin{bmatrix} 0 \\ 2 \end{bmatrix}$

[1 mark]

- 3
(2.7) The point A lies on the curve with equation $y = x^3 + px^2 + qx + 12$

- 3 (a) Given that A has coordinates $(-5, 37)$, show that $5p - q = 30$

[2 marks]

- 3 (b) Given that A is a stationary point, show that $10p - q = 75$

[3 marks]

- 3 (c) Hence find the value of p and the value of q

[1 mark]

- 3 (d) The curve with equation $y = x^3 + px^2 + qx + 12$ has a second stationary point B . Find the coordinates of B . Fully justify your answer.

[3 marks]

- 4
(1.5) Find $\int (4x - 3 + x^{-\frac{1}{2}}) dx$

[3 marks]

- 5
(2.4) Solve the equation $5^{x-1} = 20$. Give your answer in an exact form.

[2 marks]

- 6 (a) State the value of
(3.4) where $a > 0$

$$\log_a a^2$$

[1 mark]

- 6 (b) Find the value of
where $a > 0$

$$\log_a \sqrt{a} - \log_a \frac{1}{a^2}$$

[2 marks]

- 7 (2.5) The diagram shows a sector AOB of a circle with centre O and radius 8 cm.

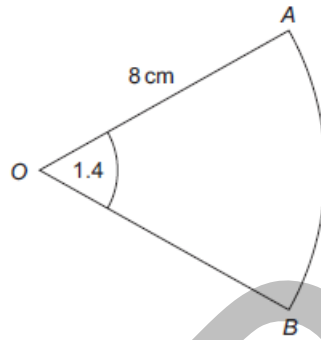

The angle AOB is 1.4 radians.
Find the area of the sector.

[2 marks]

- 8 (1.7) It is given that $0 < a < 1$
Sketch the graph with equation
 $y = a^x$
on the axes below.

$$y = a^x$$

[2 marks]

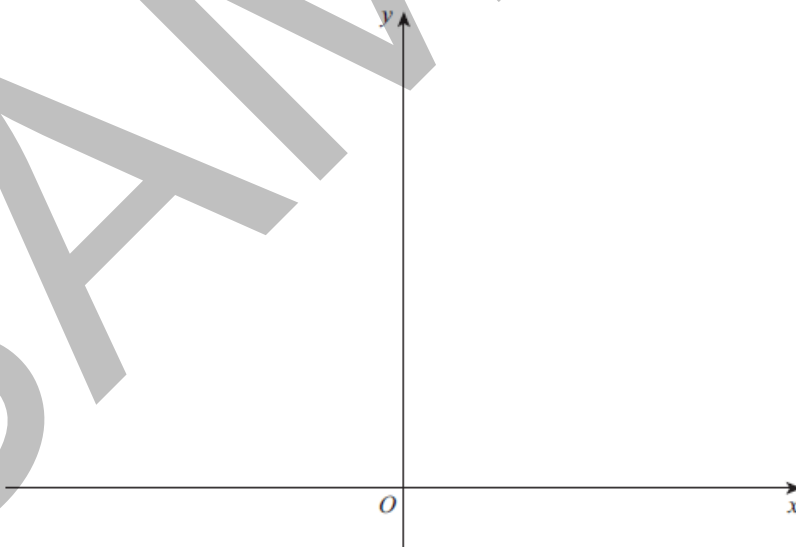

- 38**
(3.11) A block of ice is melting.
At time t minutes, the block is in the shape of a cuboid with dimensions of $4x$, $2x$ and x , as shown in the diagram.

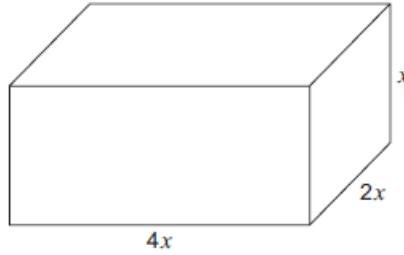

- All measurements are in centimetres.
- 38 (a)** The volume, V cm³, of the block of ice **decreases** at a rate which is proportional to its surface area.
When $x = 4$ the volume of the block of ice is decreasing at a rate of 7 cm³ per minute.
Show that

$$\frac{dV}{dt} = -0.4375x^2$$

- 38 (b)** Find $\frac{dV}{dx}$ in terms of x [4 marks]
- 38 (c) (i)** Using the results from parts **(a)** and **(b)**, find $\frac{dx}{dt}$ [2 marks]
- 38 (c) (ii)** Interpret, in context, your answer to part **(c)(i)**. [2 marks]
- 39**
(3.12) Given that the real numbers a , b , and c are such that
 $a \times b = c$
Use proof by contradiction to show that if c is irrational then at least one of a or b is irrational. [3 marks]

END OF QUESTIONS

Copyright information

For confidentiality purposes, all acknowledgements of third-party copyright material are published in a separate booklet. This booklet is published after each live examination series and is available for free download from www.aqa.org.uk.

Permission to reproduce all copyright material has been applied for. In some cases, efforts to contact copyright-holders may have been unsuccessful and AQA will be happy to rectify any omissions of acknowledgements. If you have any queries please contact the Copyright Team.

Copyright © 2025 AQA and its licensors. All rights reserved.