

A



Surname \_\_\_\_\_

Other Names \_\_\_\_\_

Centre Number \_\_\_\_\_

Candidate Number \_\_\_\_\_

Candidate Signature \_\_\_\_\_

I declare this is my own work.

**GCSE**

**COMPUTER SCIENCE**

**Paper 1 Computational Thinking and Problem-Solving**

**8520/1**

**Time allowed: 1 hour 30 minutes**

**At the top of the page, write your surname and other names, your centre number, your candidate number and add your signature.**

**[Turn over]**



JUN 21 8520101

**There are no additional materials required for this paper.**



## **INSTRUCTIONS**

- **Use black ink or black ball-point pen. Use pencil only for drawing.**
- **Answer ALL questions.**
- **You must answer the questions in the spaces provided.**
- **If you need extra space for your answer(s), use the lined pages at the end of this book. Write the question number against your answer(s).**
- **Do all rough work in this book. Cross through any work you do not want to be marked.**
- **Unless the question states otherwise, you are free to answer questions that require a coded solution in whatever format you prefer as long as your meaning is clear and unambiguous.**
- **You must NOT use a calculator.**

## **INFORMATION**

**The total number of marks available for this paper is 80.**



**ADVICE**

For the multiple choice questions, completely fill in the lozenge alongside the appropriate answer.

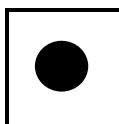
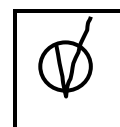
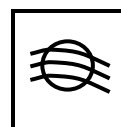
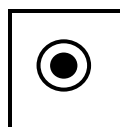
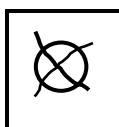
**CORRECT METHOD****WRONG METHODS**

If you want to change your answer you must cross out your original answer as shown.

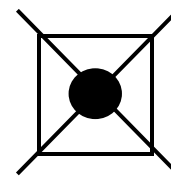

If you wish to return to an answer previously crossed out, ring the answer you now wish to select as shown.

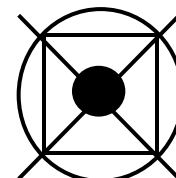

**DO NOT TURN OVER UNTIL TOLD TO DO SO**



**Answer ALL questions.**

0	1
---	---

**Match the computer science process to each correct label.**

**You should write a label A–F next to each process.**

**You should NOT use the same label more than once.**  
**[3 marks]**

- A Abstraction**
- B Data validation**
- C Decomposition**
- D Efficiency**
- E Random number generation**
- F Variable assignment**



<b>PROCESS</b>	<b>LABEL (A–F)</b>
<b>Breaking down a problem into sub-problems.</b>	
<b>Removing unimportant details.</b>	
<b>Ensuring the user enters data that is allowed, for example within a correct range.</b>	

[Turn over]

<hr/>
<b>3</b>



0	2
---	---

The algorithm shown in FIGURE 1, on the opposite page, is designed to help an athlete with their training. It uses two subroutines `getBPM` and `wait`:

- `getBPM()` returns the athlete's heart rate in beats per minute from an external input device
- `wait(n)` pauses the execution of the algorithm for `n` seconds, so `wait(60)` would pause the algorithm for 60 seconds.

Line numbers have been included but are not part of the algorithm.

0	2	.	1
---	---	---	---

State the most appropriate data type of the variable `seconds` in the algorithm shown in FIGURE 1. [1 mark]

---

---

---



**FIGURE 1**

```
1  seconds ← 0
2  rest ← 50
3  REPEAT
4      bpm ← getBPM()
5      effort ← bpm - rest
6      IF effort ≤ 30 THEN
7          OUTPUT 'faster'
8      ELSE
9          IF effort ≤ 50 THEN
10             OUTPUT 'steady'
11          ELSE
12             OUTPUT 'slower'
13          ENDIF
14      ENDIF
15      wait(60)
16      seconds ← seconds + 60
17 UNTIL seconds > 200
```

**[Turn over]**

**REPEAT OF FIGURE 1**

```
1  seconds ← 0
2  rest ← 50
3  REPEAT
4      bpm ← getBPM()
5      effort ← bpm - rest
6      IF effort ≤ 30 THEN
7          OUTPUT 'faster'
8      ELSE
9          IF effort ≤ 50 THEN
10             OUTPUT 'steady'
11         ELSE
12             OUTPUT 'slower'
13         ENDIF
14     ENDIF
15     wait(60)
16     seconds ← seconds + 60
17 UNTIL seconds > 200
```



0	2	.	2
---	---	---	---

**Explain why `rest` could have been defined as a constant in the algorithm shown in FIGURE 1. [1 mark]**

---

---

---

0	2	.	3
---	---	---	---

**State the line number where iteration is first used in the algorithm shown in FIGURE 1. [1 mark]**

---

---

---

**[Turn over]**



**REPEAT OF FIGURE 1**

```
1  seconds ← 0
2  rest ← 50
3  REPEAT
4      bpm ← getBPM()
5      effort ← bpm - rest
6      IF effort ≤ 30 THEN
7          OUTPUT 'faster'
8      ELSE
9          IF effort ≤ 50 THEN
10             OUTPUT 'steady'
11         ELSE
12             OUTPUT 'slower'
13         ENDIF
14     ENDIF
15     wait(60)
16     seconds ← seconds + 60
17 UNTIL seconds > 200
```



0 2 . 4

Complete the trace table for the algorithm shown in FIGURE 1.

Some values have already been entered in the trace table:

- the first value of `seconds`
- the values returned by the subroutine `getBPM` that are assigned to the variable `bpm`.

You may not need to use all rows of the trace table.  
[4 marks]

<code>seconds</code>	<code>bpm</code>	<code>effort</code>	OUTPUT
0	70		
	80		
	100		
	120		

[Turn over]

7
---



0	3
---	---

**A developer is writing a program to convert a sequence of integers that represent playing cards to Unicode text.**

**The developer has identified that they need to create the subroutines shown in FIGURE 2, on the opposite page, to complete the program.**

0	3	.	1
---	---	---	---

**Explain how the developer has used the structured approach to programming. [2 marks]**

---

---

---

---

---

---

---

---



FIGURE 2

SUBROUTINE	PURPOSE
getSuit(n)	<p><b>Returns:</b></p> <ul style="list-style-type: none"> <li>• <b>the string 'hearts' if n is 0</b></li> <li>• <b>the string 'diamonds' if n is 1</b></li> <li>• <b>the string 'spades' if n is 2</b></li> <li>• <b>the string 'clubs' if n is 3.</b></li> </ul>
getRank(n)	<p><b>Returns the number value of the card as a string, for example:</b></p> <ul style="list-style-type: none"> <li>• <b>if n is 1 then 'ace' is returned</b></li> <li>• <b>if n is 2 then 'two' is returned</b></li> <li>• <b>if n is 10 then 'ten' is returned</b></li> <li>• <b>if n is 11 then 'jack' is returned.</b></li> </ul>
convert(cards)	<p><b>Returns the complete string representation of the array cards. For example:</b></p> <ul style="list-style-type: none"> <li>• <b>if cards is [3, 1], the string returned would be 'three of diamonds '</b></li> <li>• <b>if cards is [1, 0, 5, 2, 7, 0], the string returned would be 'ace of hearts five of spades seven of hearts'.</b></li> </ul>

[Turn over]



**BLANK PAGE**



**03.2**

**State TWO benefits to the developer of using the three separate subroutines described in FIGURE 2, on page 13, instead of writing the program without using subroutines. [2 marks]**

---

---

---

---

---

---

---

**[Turn over]**



03.3

**FIGURE 3** shows the subroutine `convert` described in **FIGURE 2**, on page 13.

Some parts of the subroutine have been replaced with the labels **L1** to **L5**.

### FIGURE 3

```

SUBROUTINE convert(cards)
  result ← ''
  max ← LEN(cards)
  index ← 0
  WHILE index < L1
    rank ← L2(cards[index])
    suit ← getSuit(cards[L3 + 1])
    c ← rank + ' of ' + suit + ' '
    result ← result + L4
    index ← index + 2
  ENDWHILE
  RETURN L5
ENDSUBROUTINE

```



**State the pseudo-code that should be written in place of the labels in the subroutine written in FIGURE 3.**

**[5 marks]**

**L1**

---

**L2**

---

**L3**

---

**L4**

---

**L5**

---

**[Turn over]**



03.4

Shade **ONE** lozenge that states why Unicode is now commonly used in preference to ASCII. [1 mark]

**A Unicode can be represented in hexadecimal.**

**B Unicode includes characters from many different alphabets.**

**C Unicode is a sequential character set.**

**D Unicode is easier to remember than ASCII.**

**E Unicode takes up less space in memory than ASCII.**

10



**BLANK PAGE**

**[Turn over]**



04.1

A student has written the following statements about representing images. Two are correct and two are incorrect:

**STATEMENT 1**

“Bitmap images are made up of pixels.”

**STATEMENT 2**

“A 2 pixel by 4 pixel bitmap image contains 16 pixels.”

**STATEMENT 3**

“A pixel is a single point in a graphical image.”

**STATEMENT 4**

“Black and white images have a minimum colour depth of two.”

Write the correct versions of the TWO incorrect statements that the student has made. [2 marks]

First corrected statement \_\_\_\_\_

\_\_\_\_\_

\_\_\_\_\_

\_\_\_\_\_

\_\_\_\_\_

Second corrected statement \_\_\_\_\_

---

---

---

---

---

**0 4 . 2**

**Calculate the minimum file size in BITS of a 10 pixel by 10 pixel image with a colour depth of 3 bits. [1 mark]**

---

---

---

**[Turn over]**





**BLANK PAGE**

**[Turn over]**



0 4 . 4

This is one row of a bitmap image that uses different shades of grey:



This row is stored using the following numbers to represent the different shades of grey:

56	34	0	99	72	23
----	----	---	----	----	----

The algorithm shown in FIGURE 4 uses this row.

#### FIGURE 4

```

row ← [56, 34, 0, 99, 72, 23]
newRow ← [0, 0, 0, 0, 0, 0]
FOR i ← 0 TO 5
    IF row[i] > 50 THEN
        newRow[i] ← 99
    ENDIF
ENDFOR

```

Complete the trace table, on the opposite page, for the algorithm shown in FIGURE 4. The first values have already been entered. You may not need to use all rows of the trace table. [3 marks]



i	newRow					
	0	1	2	3	4	5
	0	0	0	0	0	0
0						

0 4 . 5

State the purpose of the algorithm shown in FIGURE 4.  
[1 mark]

---



---

[Turn over]

10
----



05.1

The following are three types of program translator:

- A Assembler
- B Compiler
- C Interpreter

Write the label (A–C) for the type of translator next to the description. [2 marks]

DESCRIPTION	LABEL (A–C)
Converts a low-level language designed to be human-readable into machine code.	
Reads a high-level program line-by-line and calls corresponding subroutines.	
Takes the entire high-level program as input and produces machine code.	



**05.2**

**State TWO advantages of programming using a high-level language compared with programming using a low-level language. [2 marks]**

**Advantage 1** \_\_\_\_\_

\_\_\_\_\_

\_\_\_\_\_

**Advantage 2** \_\_\_\_\_

\_\_\_\_\_

\_\_\_\_\_

**[Turn over]**



0	5	.	3
---	---	---	---

**Develop an algorithm, using either pseudo-code or a flowchart, that checks if the user has entered a string that represents a valid machine code instruction.**

**The machine code instruction is valid if it contains exactly eight characters AND all of those characters are either '0' or '1'.**

**The algorithm should:**

- **prompt the user to enter an 8-bit machine code instruction and store it in a variable**
- **check that the instruction only contains the characters '0' or '1'**
- **check that the instruction is exactly eight characters long**
- **output 'ok' when the instruction is valid, otherwise it should output 'wrong'.**

**For example:**

- **if the user enters the string '00101110' it should output 'ok'**
- **if the user enters the string '11110' it should output 'wrong'**
- **if the user enters the string '1x011001' it should output 'wrong'.**

**[9 marks]**











0	6	.	3
---	---	---	---

**State why binary search is considered a better algorithm than linear search. [1 mark]**

---

---

---

**[Turn over]**



The algorithm in FIGURE 5 is a new search algorithm.

### FIGURE 5

```
arr ← [3, 4, 6, 7, 11, 14, 17, 18, 34, 42]
value ← 21
found ← False
finished ← False
i ← 0
down ← False
WHILE (found = False) AND (finished = False)
  IF arr[i] = value THEN
    found ← True
  ELSE
    IF arr[i] > value THEN
      down ← True
      i ← i - 1
    ELSE
      IF (arr[i] < value) AND (down = True) THEN
        finished ← True
```



```

ELSE
    i ← i + 4
ENDIF
ENDIF
ENDIF
ENDWHILE

```

**Complete the trace table for the algorithm in FIGURE 5. The first row has been completed for you. You may not need to use all rows of the trace table. [4 marks]**

found	finished	i	down
False	False	0	False

**[Turn over]**

11
----



07.1

Draw the logic circuit, using only one logic gate, that is represented by the following truth table:

Input A	Input B	Output Q
0	0	0
0	1	1
1	0	1
1	1	1

[1 mark]

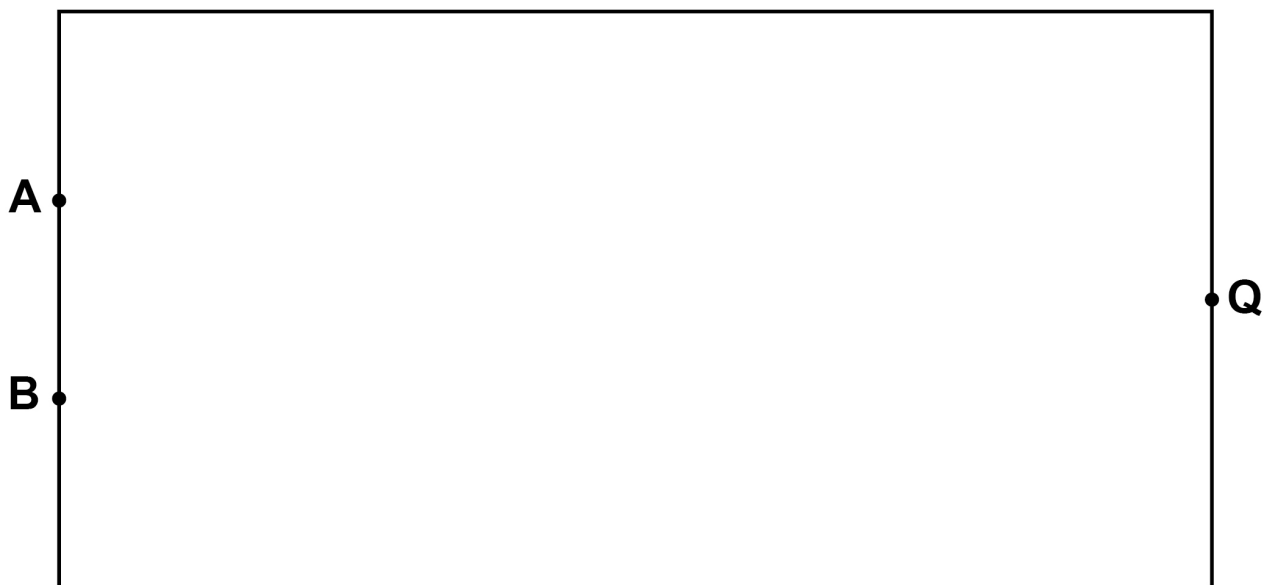

07.2

Shade ONE lozenge to show the Boolean expression that is equivalent to the logic circuit shown in FIGURE 6.

FIGURE 6

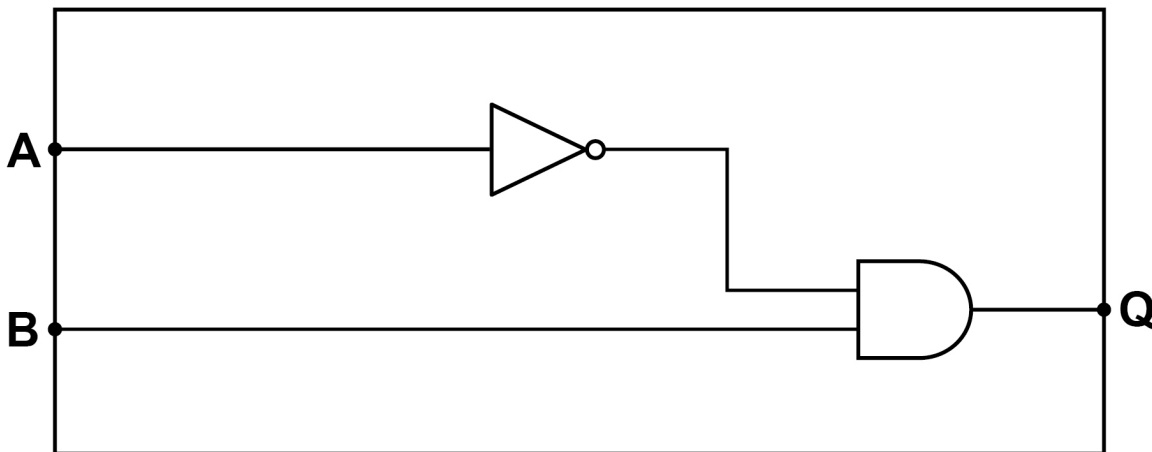

[1 mark]

**A** A AND NOT B**B** NOT (A AND B)**C** (NOT A) AND B**D** (NOT A) AND (NOT B)

[Turn over]



07.3

Shade ONE lozenge to show the Boolean expression which is equivalent to the logic circuit shown in FIGURE 7.

FIGURE 7

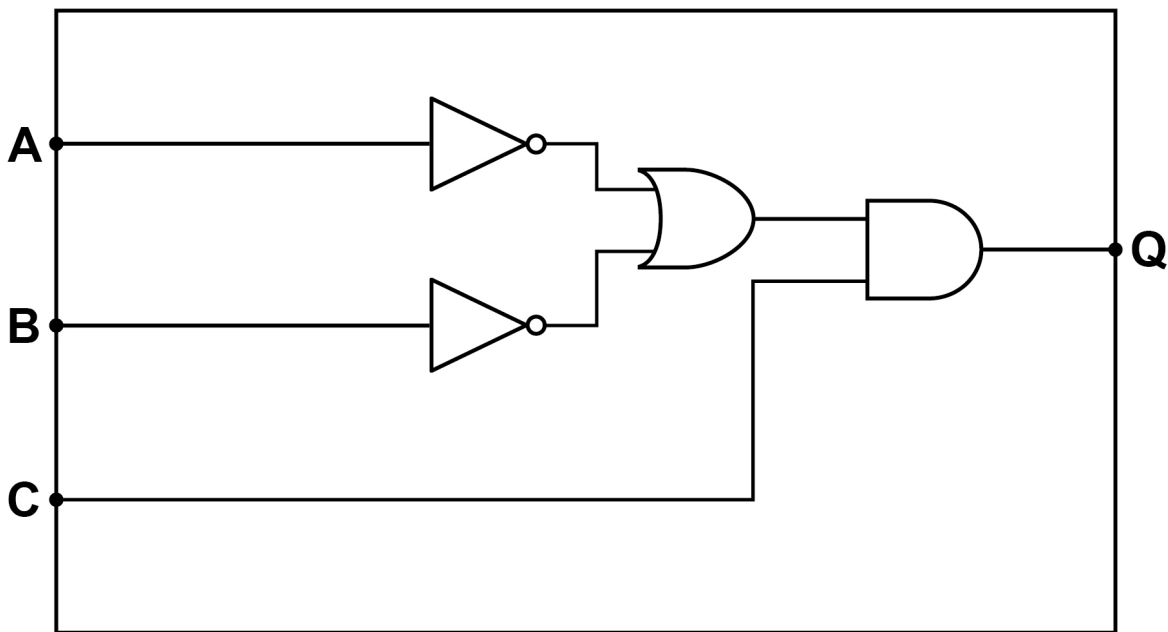

[1 mark]

**A** NOT ((A OR B) AND C)

**B** (NOT A) OR ((NOT B) AND C)

**C** (NOT (A OR B)) AND C

**D** ((NOT A) OR (NOT B)) AND C

**[Turn over]**



**07.4****FIGURE 8 shows an algorithm.****FIGURE 8**

```
x ← True
y ← False
IF NOT (x AND y) THEN
    OUTPUT 'A'
    IF NOT((NOT x) OR (NOT y)) THEN
        OUTPUT 'B'
    ELSE
        OUTPUT 'C'
    ENDIF
ELSE
    OUTPUT 'D'
    IF (NOT x) AND (NOT y) THEN
        OUTPUT 'E'
    ELSE
        OUTPUT 'F'
    ENDIF
ENDIF
```



**State the output from the algorithm shown in FIGURE 8.  
[2 marks]**

---

---

---

---

---

---

---

**[Turn over]**

07.5

Draw a logic circuit in the box below for the following scenario.

A sewing machine is running (R) if either the foot pedal is on (F) or the hand dial is on (H) but not both.

You should use **ONLY** the gates AND, OR and NOT in your answer. [3 marks]







---

---

---

---

---

---

---

---

---

---

[Turn over]

11



08

Number the following lines of code in order (1–4) so that they create an algorithm where the final value of the variable  $n$  is 13.

The LEFTSHIFT operator performs a binary left shift. For example,  $4 \text{ LEFTSHIFT } 2$  would left shift the value 4 twice. [3 marks]

Line of code	Position (1–4 where 1 is the first line)
$t \leftarrow t - 1$	
$n \leftarrow t - n$	
$n \leftarrow 2$	
$t \leftarrow n \text{ LEFTSHIFT } 3$	

3
---



09

The **ALGEBRAIC PATENT SEWING MACHINE** is a programmable sewing machine that creates patterns on rows of cloth. It is controlled by writing programs that use the following subroutines:

SUBROUTINE	DESCRIPTION
<code>gotoRow (n)</code>	start the sewing machine needle at the left-hand side of row $n$
<code>move (n)</code>	move the needle forward by $n$ cells without producing a pattern
<code>shape (s)</code>	produce shape $s$ where $s$ can be 'square' or 'circle' and move the needle to the next cell
<code>atEnd ()</code>	returns <code>True</code> if the needle is at the end of the row or <code>False</code> otherwise

For example, if the cloth looks like this to begin with:

Row 0				
Row 1				
Row 2				

[Turn over]



The subroutine call `gotoRow(2)` will place the sewing machine needle at the point shown by the black cross:

Row 0				
Row 1				
Row 2	×			

The subroutine call `move(3)` will move the sewing machine needle to the point shown by the black cross:

Row 0				
Row 1				
Row 2				×

The subroutine call `gotoRow(1)` will move the sewing machine needle to the point shown by the black cross:

Row 0				
Row 1	×			
Row 2				

The subroutine call `shape('square')` will draw the following pattern and move the sewing machine needle to the point shown by the black cross:

Row 0				
Row 1		×		
Row 2				

[Turn over]



And finally, the subroutine call `shape('circle')` will draw the following pattern and move the sewing machine needle to the point shown by the black cross:

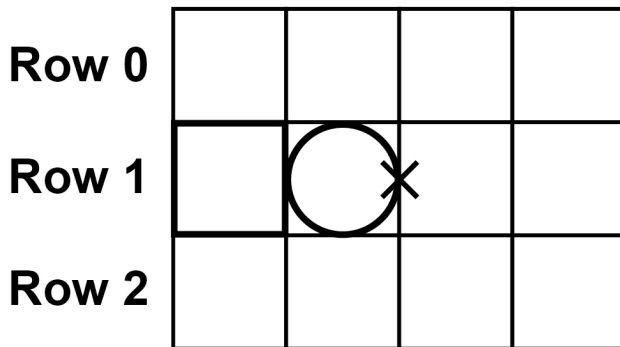

All of the previous positions of the sewing machine needle would result in the subroutine call `atEnd()` returning `False`, however in the following example `atEnd()` would return `True`:

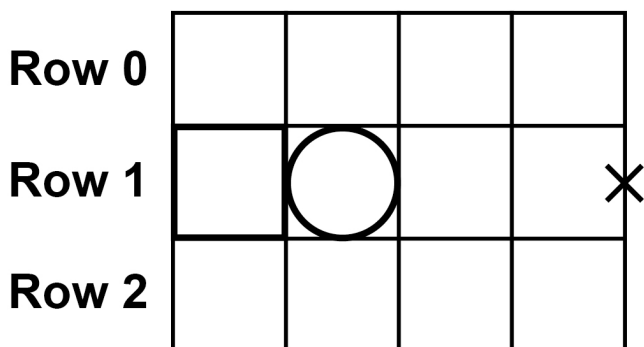

**0 9 . 1**

Draw the final pattern after the following algorithm has executed.



```
gotoRow(0)
WHILE atEnd() = False
    shape('square')
    move(1)
ENDWHILE
gotoRow(1)
shape('circle')
move(1)
IF atEnd() = True THEN
    gotoRow(2)
ELSE
    move(1)
ENDIF
shape('square')
```

**You should draw your answer on the following grid.**

**You do not need to show the position(s) of the needle in your answer. [4 marks]**

<b>Row 0</b>				
<b>Row 1</b>				
<b>Row 2</b>				

**[Turn over]**



09.2

**Draw the final pattern after the following algorithm has executed.**

**This question uses the MOD operator. MOD calculates the remainder after integer division, for example  $7 \text{ MOD } 5 = 2$ .**

```
patterns ← ['circle', 'square', 'square', 'circle']  
r ← 2  
FOR k ← 0 TO 3  
    gotoRow(k MOD r)  
    move(k + 1)  
    shape(patterns[k])  
ENDFOR
```

**On the opposite page, you should draw your answer on the grid.**

**You do not need to show the position(s) of the needle in your answer. [4 marks]**



Row 0

Row 1

Row 2

Row 3

[Turn over]



0	9	.	3
---	---	---	---

Develop an algorithm, using either pseudo-code or a flowchart, to produce the pattern shown in FIGURE 9.

To gain full marks your answer must make appropriate use of iteration.

**FIGURE 9**

Row 0							
Row 1							
Row 2							
Row 3							

**[4 marks]**

---

---

---

---

---









**BLANK PAGE**

For Examiner's Use	
Question	Mark
1	
2	
3	
4	
5	
6	
7	
8	
9	
<b>TOTAL</b>	

**Copyright information**

For confidentiality purposes, all acknowledgements of third-party copyright material are published in a separate booklet. This booklet is published after each live examination series and is available for free download from [www.aqa.org.uk](http://www.aqa.org.uk).

Permission to reproduce all copyright material has been applied for. In some cases, efforts to contact copyright-holders may have been unsuccessful and AQA will be happy to rectify any omissions of acknowledgements. If you have any queries please contact the Copyright Team.

Copyright © 2021 AQA and its licensors. All rights reserved.

**IB/M/CD/Jun21/8520/1/E2**