



Surname _____

Forename(s) _____

Centre Number _____

Candidate Number _____

Candidate Signature _____

I declare this is my own work.

GCSE

ENGINEERING

Unit 1 Written Paper

8852/W

Wednesday 12 June 2024

Morning

Time allowed: 2 hours

At the top of the page, write your surname and forename(s), your centre number, your candidate number and add your signature.

[Turn over]



MATERIALS

For this paper you must have:

- normal writing and drawing instruments
- a calculator.

INSTRUCTIONS

- Use black ink or black ball-point pen. Use pencil only for drawing.
- Answer ALL questions.
- You must answer the questions in the spaces provided. Do not write on blank pages.
- If you need extra space for your answer(s), use the lined pages at the end of this book. Write the question number against your answer(s).
- Some questions will require you to shade a circle. If you make a mistake cross through the incorrect answer.
- Do all rough work in this book. Cross through any work you do not want to be marked.



INFORMATION

- **The marks for questions are shown in brackets.**
- **The maximum mark for this paper is 120.**
- **You are reminded of the need for good English and clear presentation in your answers.**

DO NOT TURN OVER UNTIL TOLD TO DO SO



Answer ALL questions in the spaces provided.

For each question completely fill in the circle alongside the appropriate answer.

CORRECT METHOD

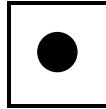

WRONG METHODS

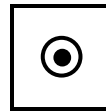
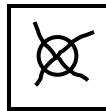

If you want to change your answer you must cross out your original answer as shown.

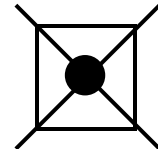

If you wish to return to an answer previously crossed out, ring the answer you now wish to select as shown.

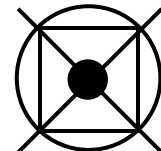

01.1

Which process used for steel involves heating then allowing the steel to cool naturally? [1 mark]

A Annealing**B Galvanising****C Hardening****D Normalising**

[Turn over]



01.2

**Which of the following is an interfacing device?
[1 mark]**

A Capacitor**B Light Dependent Resistor****C Light Emitting Diode****D Transistor**

01.3

Which of the following forces keeps an aeroplane in the air? [1 mark]

A Drag**B Friction****C Lift****D Thrust**

[Turn over]



01.4

Which is the correct formula for calculating Young's modulus (E)? [1 mark]

A Young's modulus = area/pressure

B Young's modulus = pressure/area

C Young's modulus = strain/stress

D Young's modulus = stress/strain



01.5

**Which TWO of the following are thermoplastics?
[2 marks]**

A Epoxy**B Nylon****C Polycarbonate****D Polyester resin****E Polyurethane****F Vulcanised rubber**

[Turn over]



0	1	.	6
---	---	---	---

Use the word bank provided, on the opposite page, to complete the following statements. [4 marks]

Brass consists of two or more different metals which means it is _____ .

The two main metals are

_____ and _____ .

Brass is non-ferrous because it does not contain

_____ .



WORD BANK

- a ceramic
- a composite
- aluminium
- an alloy
- bronze
- carbon fibre
- copper
- gold
- iron
- lead
- nickel
- zinc

[Turn over]

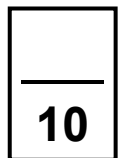

02.1

Sintering is a process used to produce metal components.

Explain the sintering process. [2 marks]



02.2

There are many different forms of manufactured board.

Identify TWO differences between Medium Density Fibreboard (MDF) and Oriented Strand Board (OSB).

[2 marks]

Difference 1 _____

Difference 2 _____

[Turn over]



02.3

Identify TWO differences between hard soldering and soft soldering. [2 marks]

Difference 1 _____

Difference 2 _____



02.4

State TWO differences between thermosetting polymers and thermoplastic polymers. [2 marks]

Difference 1 _____

Difference 2 _____

[Turn over]

8



03.2

Material testing is often used to make sure a material is suitable for a particular purpose.

Name ONE non-destructive test and ONE destructive test. [2 marks]

Non-destructive test _____

Destructive test _____

[Turn over]



03.4

Explain how altering the amount of carbon content changes the properties of steel. [2 marks]

03.5

Give ONE use of high carbon steel. [1 mark]

[Turn over]



03.6

State ONE routine maintenance check that should be carried out on a drilling machine. [1 mark]

03.7

Explain the importance of carrying out routine maintenance checks. [2 marks]

15



BLANK PAGE

[Turn over]



04.1

FIGURE 1 shows a pulley system that is being used to lift a heavy load.

FIGURE 1

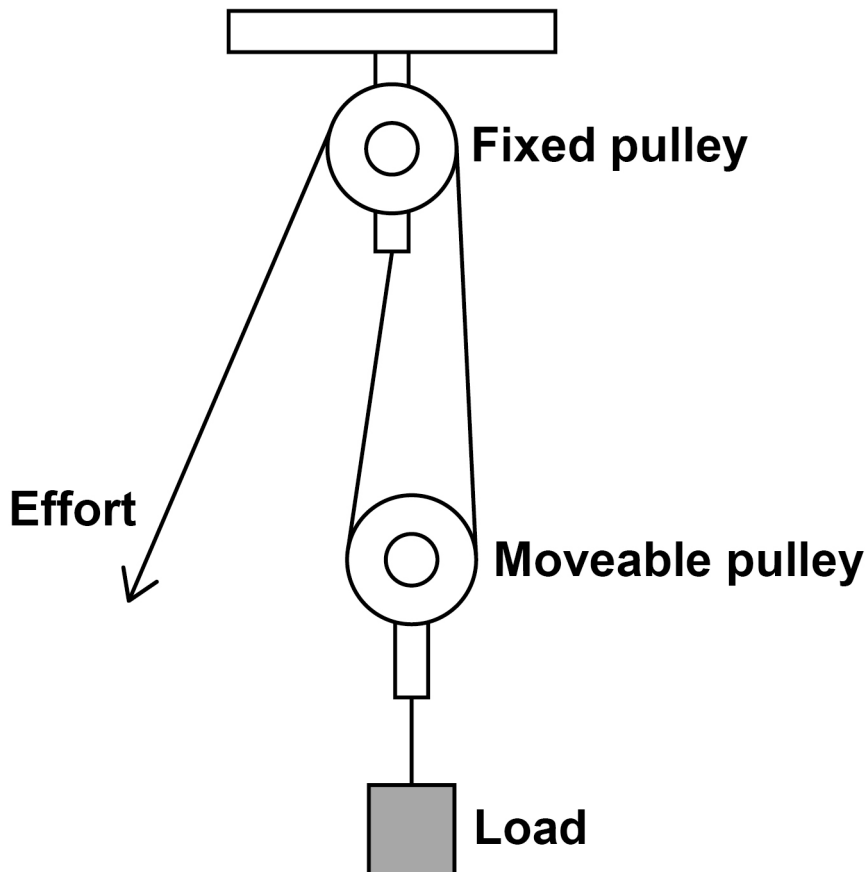

Analyse the benefits of using a pulley system for lifting heavy loads. [4 marks]



04.3

The pulleys are made from aluminium using the sand-casting process.

Identify any TWO stages in the sand-casting process.
[2 marks]

[Turn over]

9





0 5

In a factory, any item that is not the correct mass must be identified and removed from a production line that is working **CONTINUOUSLY**.

A microcontroller uses a sensor to weigh each item and a lever is used to remove the item if it is not the correct mass.

0 5 . 1

Complete the systems block diagram by adding the missing terms at the **THREE** points: A, B and C. [3 marks]

26

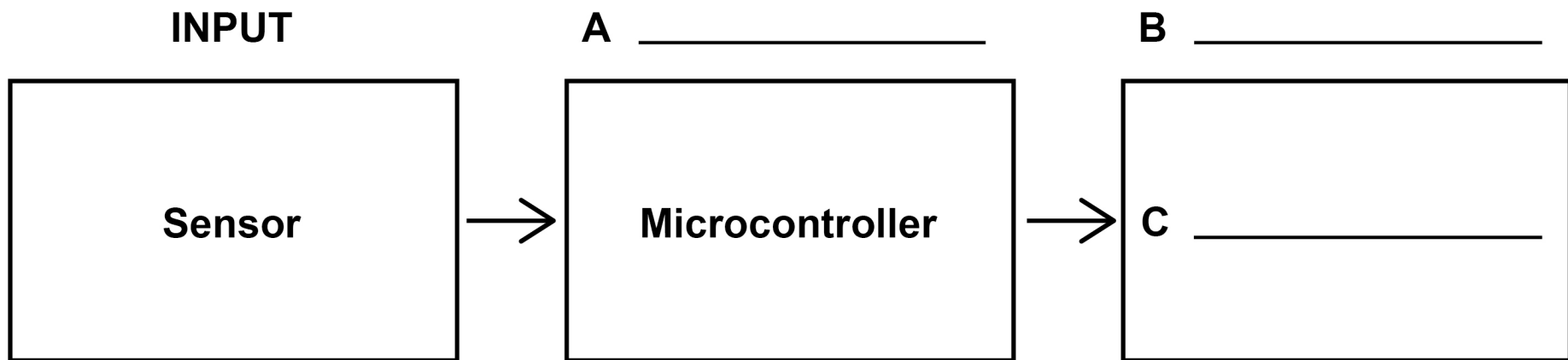

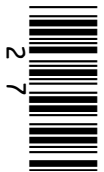

BLANK PAGE

[Turn over]

0	5	.	2
---	---	---	---

Complete the flowchart, on the opposite page, so that the production line system will operate correctly.

[4 marks]



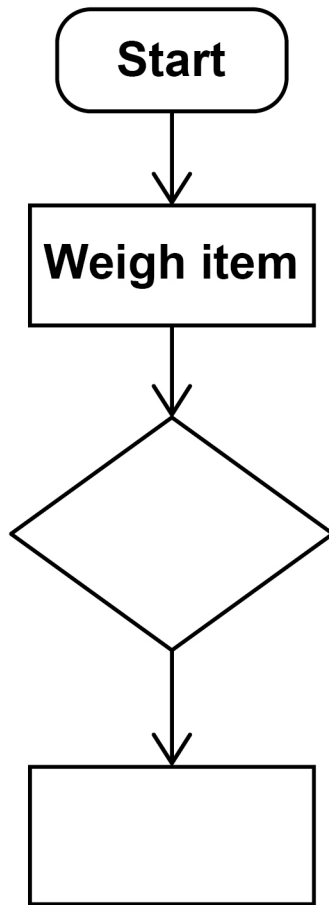

[Turn over]



[Turn over]

13



06

A student wants to make a simple rectangular aluminium box as shown in FIGURE 2.

FIGURE 2

Material: 2 mm thick aluminium sheet
All dimensions in millimetres

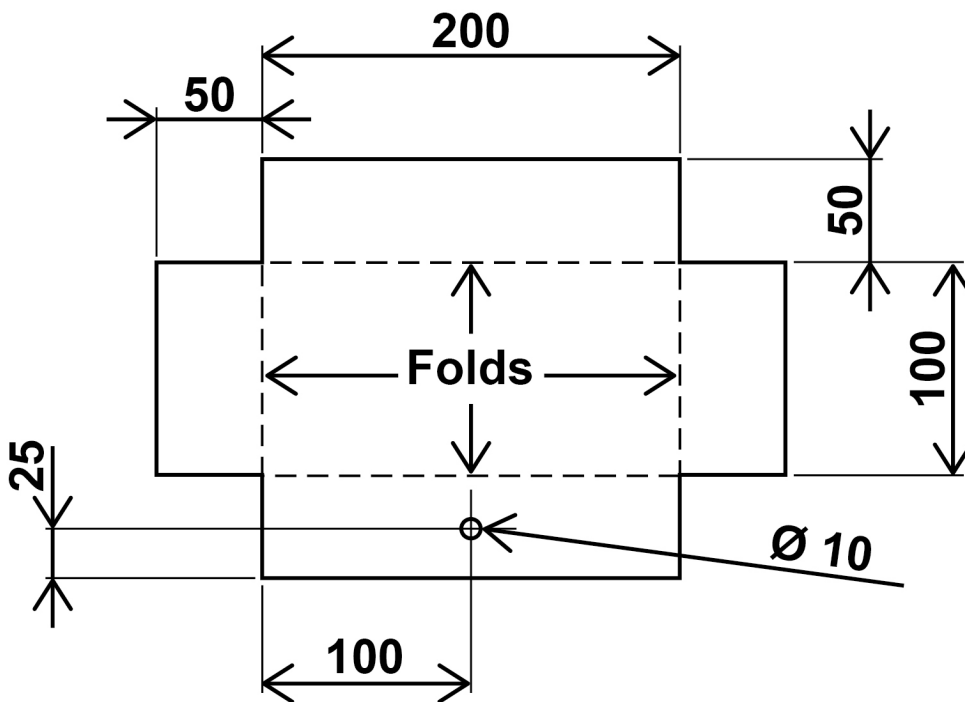

10 mm hole in
centre of side

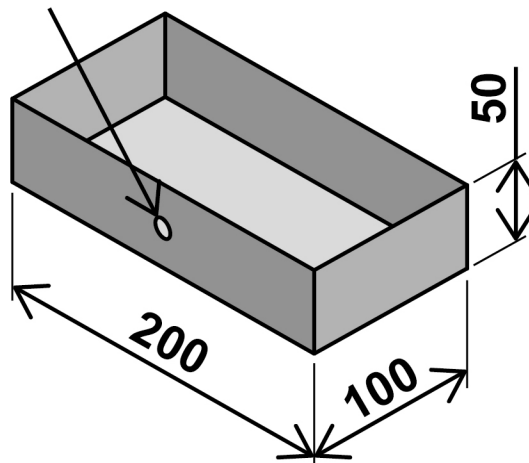

The 10 mm hole is drilled into the 2 mm thick aluminium sheet using a drilling machine. The sheet is then cut and folded into shape.

06.1

Using notes and/or sketches, explain how the student could secure the aluminium sheet and drill the 10 mm hole using a drilling machine.

Include all safety precautions. [6 marks]

[Turn over]



0	6	.	2
---	---	---	---

After drilling, the corners, shown shaded in FIGURE 3, are removed.

FIGURE 3

All dimensions
in millimetres

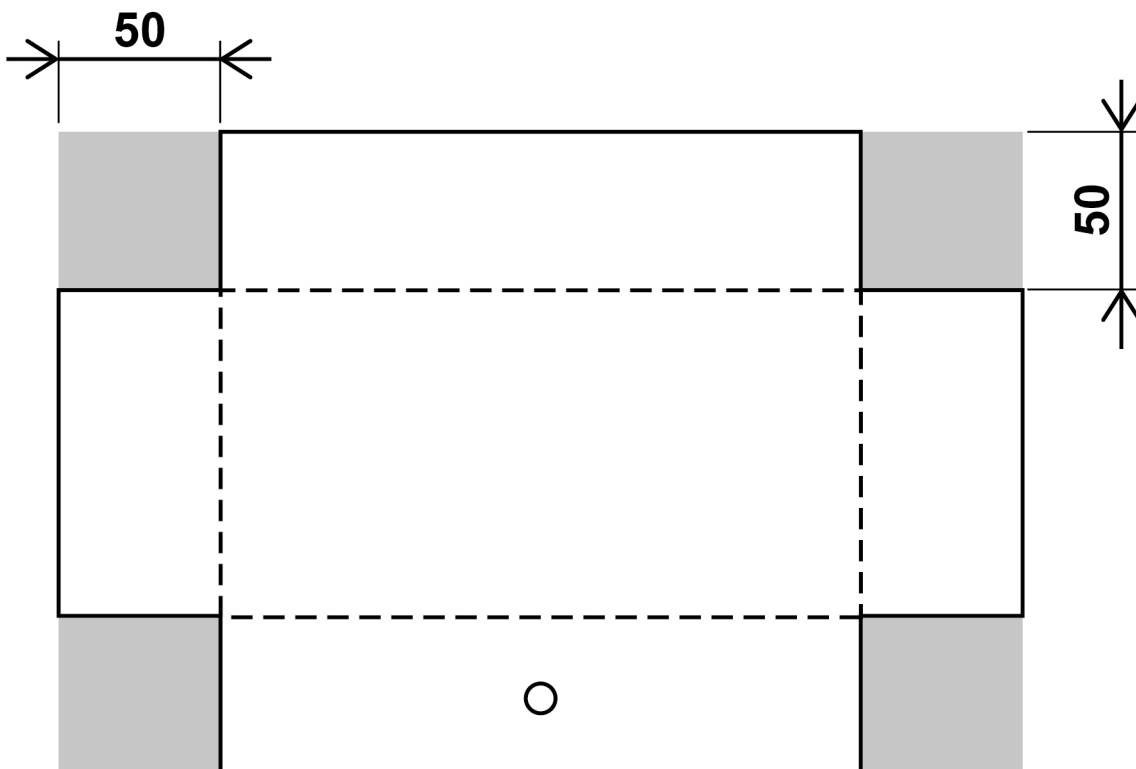

[Turn over]



FIGURE 4 shows a tool suitable for removing the corners.

FIGURE 4



Name the tool shown in FIGURE 4. [1 mark]

0 6 . 3

Evaluate why the tool shown in FIGURE 4 is suitable for removing the corners as shown in FIGURE 3 on page 35. [3 marks]



[Turn over]



FIGURE 2 is repeated below.

FIGURE 2

Material: 2 mm thick aluminium sheet
All dimensions in millimetres

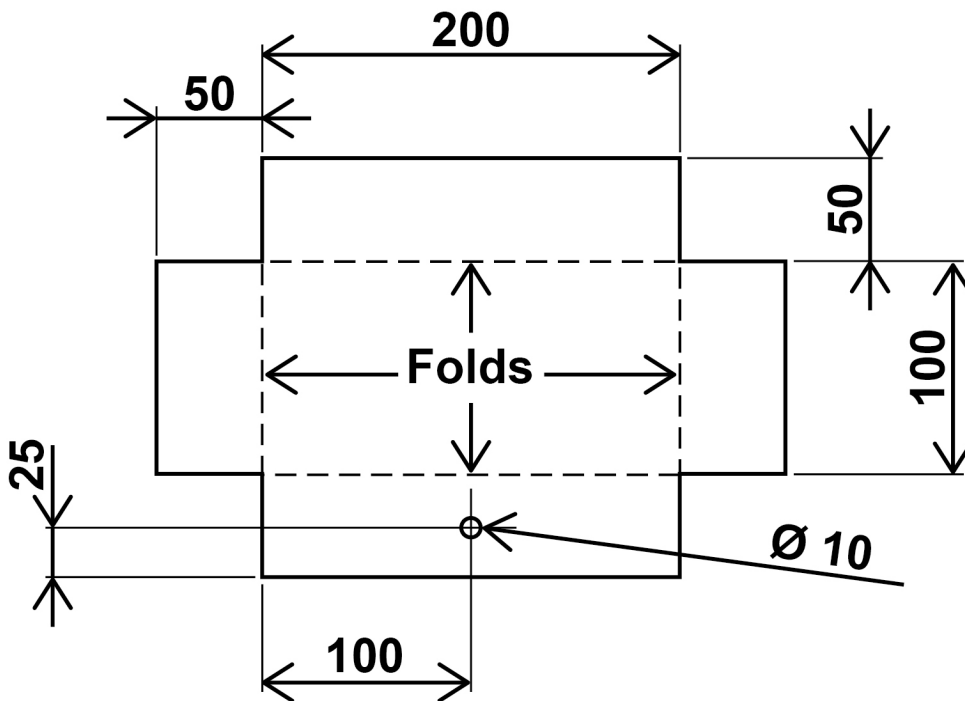

10 mm hole in
centre of side

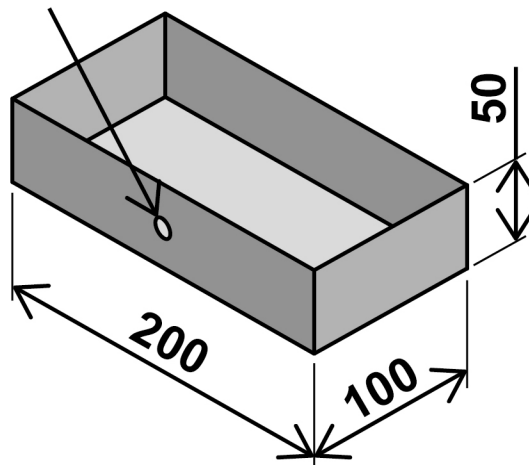
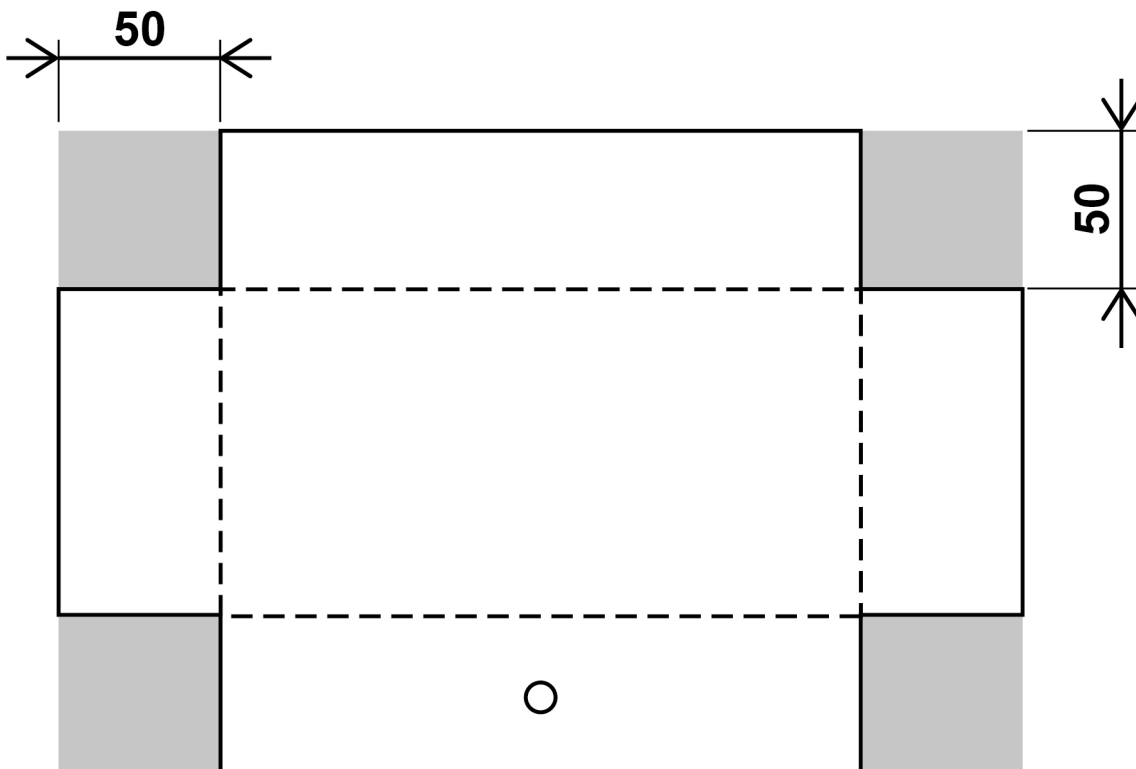

FIGURE 3 is repeated below.

FIGURE 3

**All dimensions
in millimetres**



0	6	.	6
---	---	---	---

The student wants to make a lid for the aluminium box using a similar method.

The total waste area for the lid is 2500 mm²

The area of the original piece of aluminium is 37 500 mm²

Calculate the percentage of material that is removed as waste.

Use the formula $\% \text{ waste} = \frac{\text{waste area}}{\text{original area}} \times 100$

Show your working.

Give your answer to TWO decimal places. [3 marks]



Answer _____ %

[Turn over]

21



07.1

**Name ONE fossil fuel used for energy production.
[1 mark]**

07.2

Biomass and wind energy are used in energy production.

Compare the advantages and disadvantages of these two energy production methods.

Discuss the following aspects in your answer:

- **technologies used**
- **impact on society.**

[8 marks]



9



BLANK PAGE

[Turn over]



08

FIGURE 5 shows an electronic system that monitors how many cars enter a car park.

The way the system operates is stated below:

- when a car enters, the driver pushes a button
- this adds 1 to a microcontroller working as a counter
- the number of cars entering the car park is shown by an LED display.

FIGURE 5

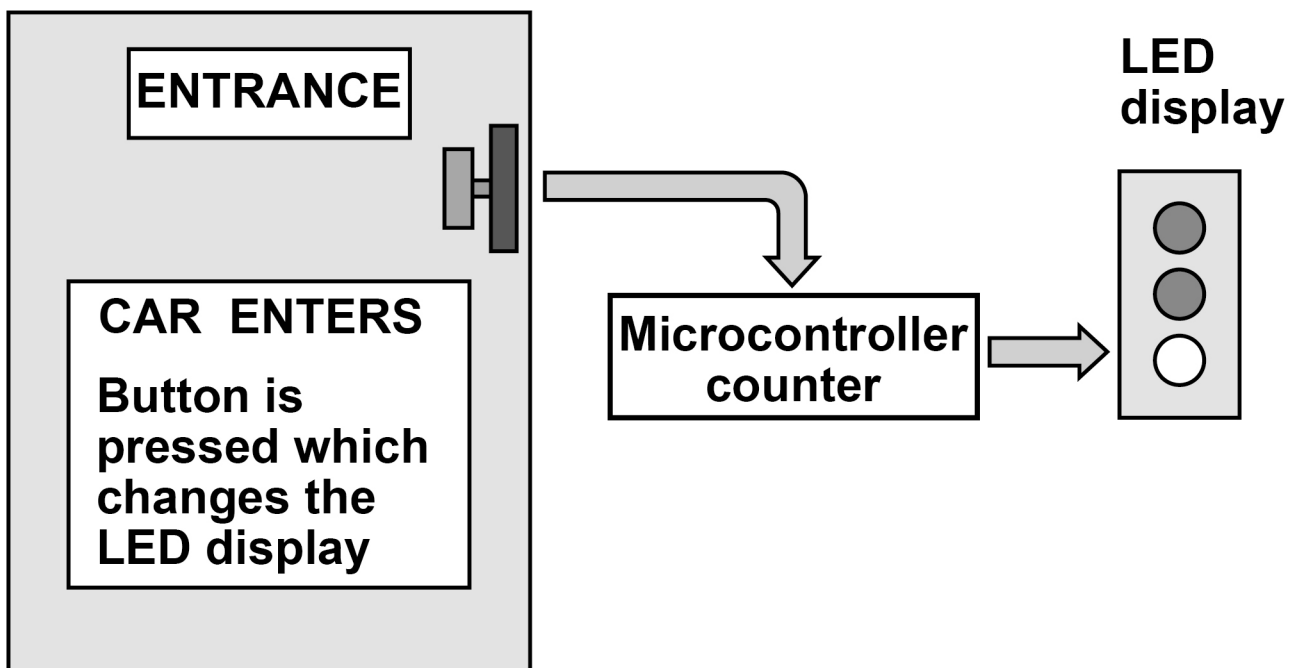

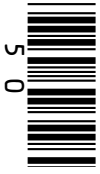

08.2

Complete the schematic drawing in FIGURE 6, on the opposite page, by correctly connecting the:

- battery to the power
- battery to ground
- switch to clock/input
- switch to power
- LEDs to outputs
- resistor R2 with the LEDs.

[6 marks]

NAMES OF SYMBOLS SHOWN

Battery

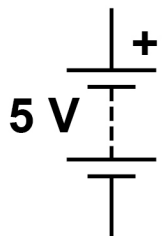

Switch

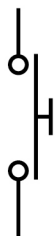

Resistor



LED

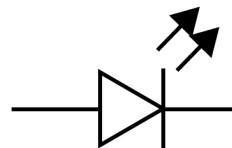
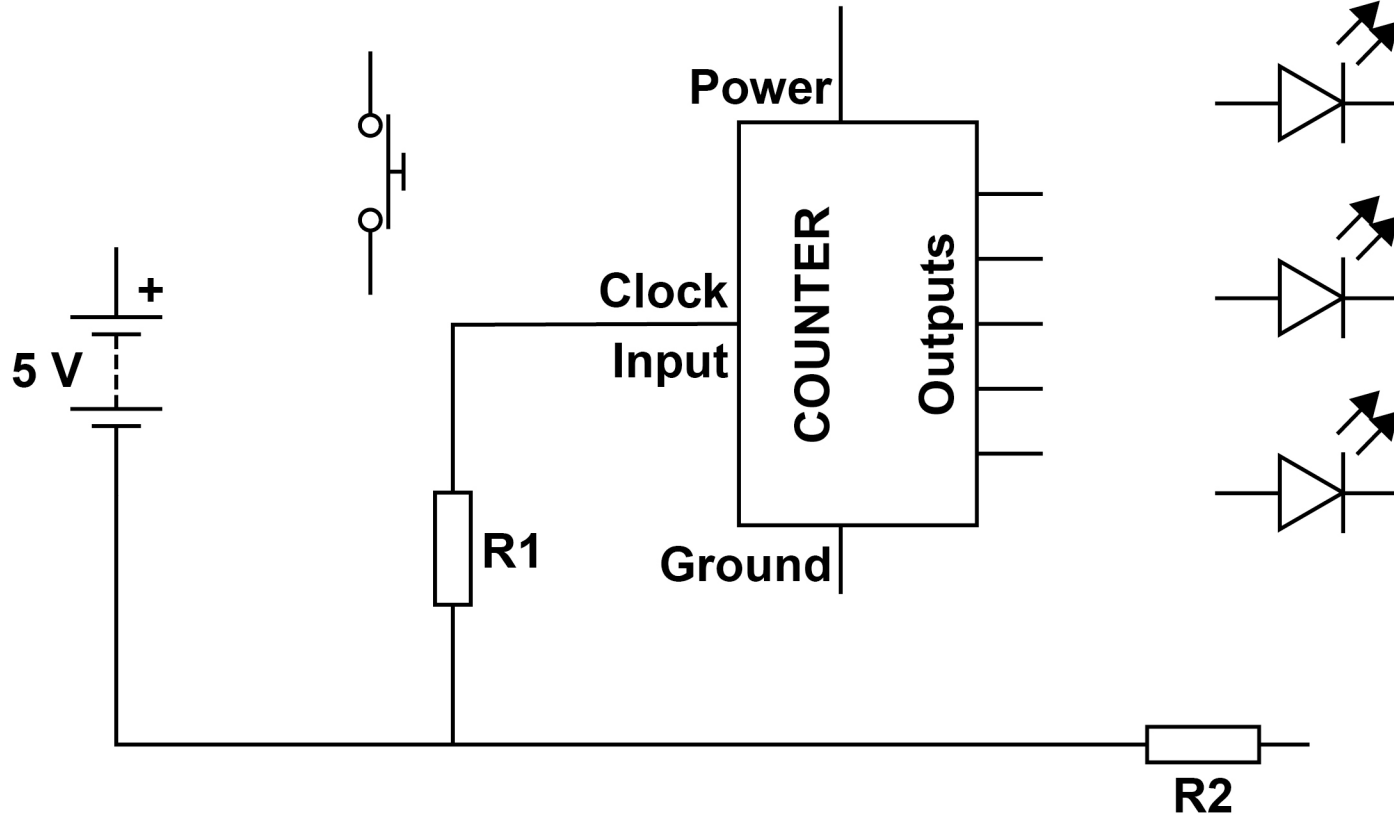



FIGURE 6



[Turn over]

FIGURE 7 shows a simple circuit connecting an LED to a battery.

FIGURE 7

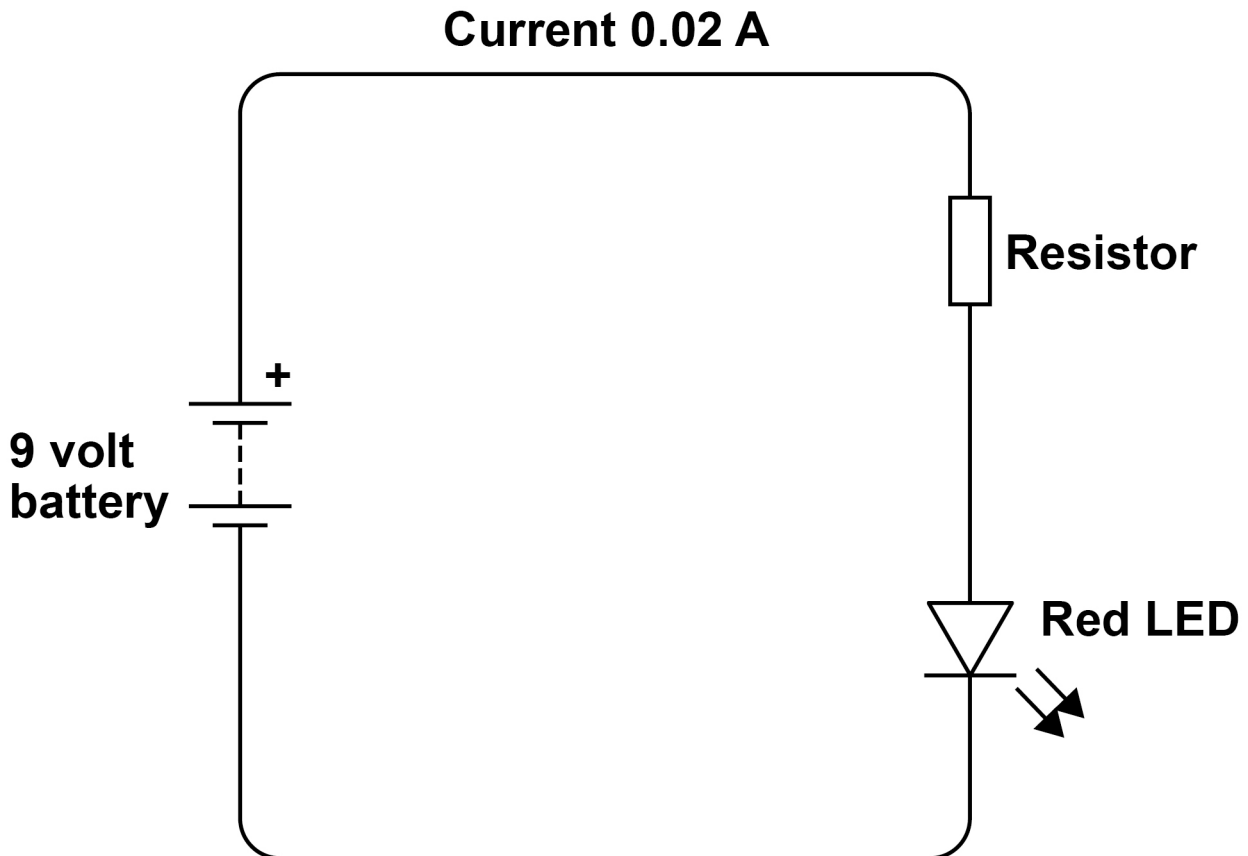

08.3

What is the function of the resistor? [1 mark]



09

FIGURE 8 shows the design for a viewing platform.

It will be fastened to sloping ground at the rear and supported at the front by two legs made from low carbon steel tube.

FIGURE 8

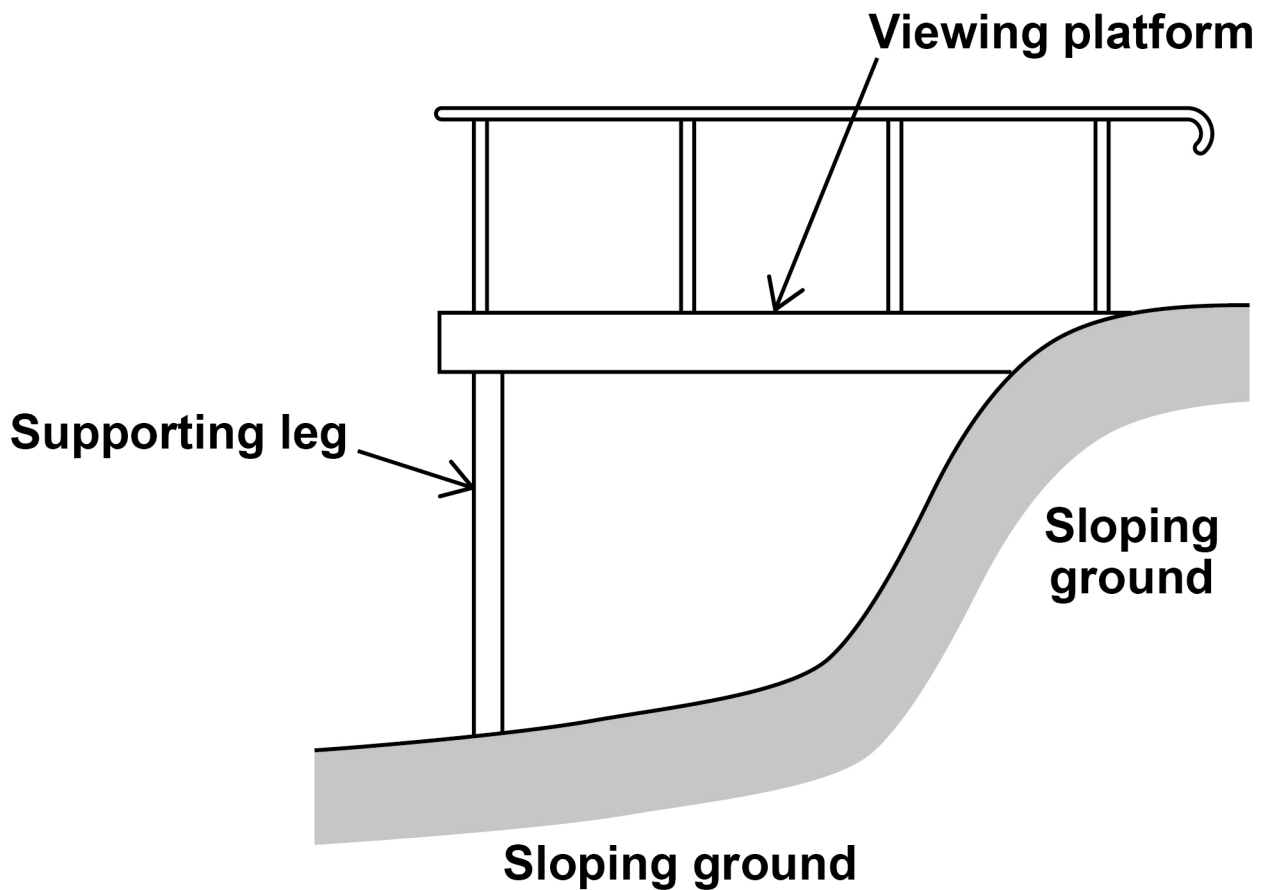

09.1

Each supporting leg will need to support 2500 N.

The maximum allowed stress of the low carbon steel is 120 N/mm²

Calculate the minimum cross-sectional area (csa) of ONE supporting leg.

Use the formula $\text{Stress} = \text{force}/\text{csa}$

Show your working. [3 marks]

[Turn over]



Answer _____ mm²

09.2

The design of the viewing platform means that there is a risk that the supporting legs may buckle.

Explain what is meant by buckling. [2 marks]



BLANK PAGE

[Turn over]



09.3

A cross-sectional view of a supporting leg is shown in FIGURE 9 below.

The leg is made from a 100 mm external diameter tube that is 1.5 m long (L) and has a wall thickness of 5 mm.

FIGURE 9

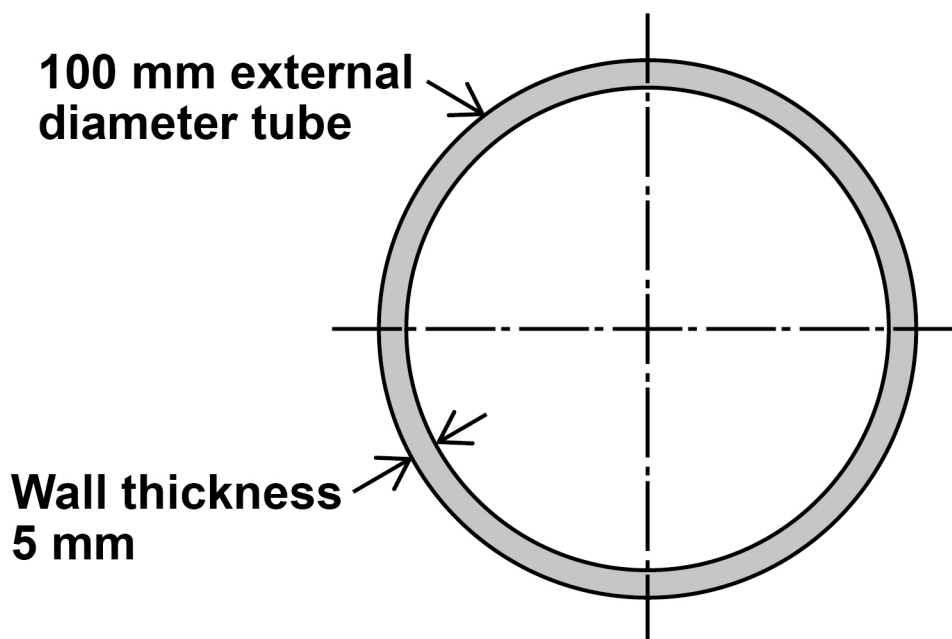

Calculate the volume of the low carbon steel used in ONE supporting leg.

Use the formula Volume of a cylinder = $\pi \times R^2 \times L$

Show your working.

Give your answer in mm^3 [6 marks]



Answer _____ **Unit** _____

0 **9** . **5**

The supporting legs will be galvanised.

State the reason why low carbon steel is galvanised.
[1 mark]

[Turn over]



0	9	.	6
---	---	---	---

Describe the galvanising process. [3 marks]



BLANK PAGE

For Examiner's Use	
Question	Mark
1	
2	
3	
4	
5	
6	
7	
8	
9	
TOTAL	

Copyright information

For confidentiality purposes, all acknowledgements of third-party copyright material are published in a separate booklet. This booklet is published after each live examination series and is available for free download from www.aqa.org.uk.

Permission to reproduce all copyright material has been applied for. In some cases, efforts to contact copyright-holders may have been unsuccessful and AQA will be happy to rectify any omissions of acknowledgements. If you have any queries please contact the Copyright Team.

Copyright © 2024 AQA and its licensors. All rights reserved.

WP/M/AM/Jun24/8852/W/G4002/V3

