



Surname _____

Forename(s) _____

Centre Number _____

Candidate Number _____

Candidate Signature _____

I declare this is my own work.

A-level

MATHEMATICS

Paper 2

7357/2

Tuesday 11 June 2024 Afternoon

Time allowed: 2 hours

At the top of the page, write your surname and forename(s), your centre number, your candidate number and add your signature.

[Turn over]



J U N 2 4 7 3 5 7 2 0 1

MATERIALS

- You must have the AQA Formulae for A-level Mathematics booklet
- You should have a graphical or scientific calculator that meets the requirements of the specification.

INSTRUCTIONS

- Use black ink or black ball-point pen. Pencil should only be used for drawing.
- Answer ALL questions.
- You must answer each question in the space provided for that question.
- If you need extra space for your answer(s), use the lined pages at the end of this book. Write the question number against your answer(s).
- Do not write on blank pages.
- Show all necessary working; otherwise marks for method may be lost.
- Do all rough work in this book. Cross through any work you do not want to be marked.



INFORMATION

- **The marks for questions are shown in brackets.**
- **The maximum mark for this paper is 100.**

ADVICE

- **Unless stated otherwise, you may quote formulae, without proof, from the booklet.**
- **You do not necessarily need to use all the space provided.**

DO NOT TURN OVER UNTIL TOLD TO DO SO



SECTION A

Answer ALL questions in the spaces provided.

- 1 One of the equations below is the equation of a circle.

Identify this equation. [1 mark]

Tick (✓) ONE box.

$$(x + 1)^2 - (y + 2)^2 = -36$$

$$(x + 1)^2 - (y + 2)^2 = 36$$

$$(x + 1)^2 + (y + 2)^2 = -36$$

$$(x + 1)^2 + (y + 2)^2 = 36$$



- 2 The graph of $y = f(x)$ intersects the x -axis at $(-3, 0)$, $(0, 0)$ and $(2, 0)$ as shown in the diagram below.

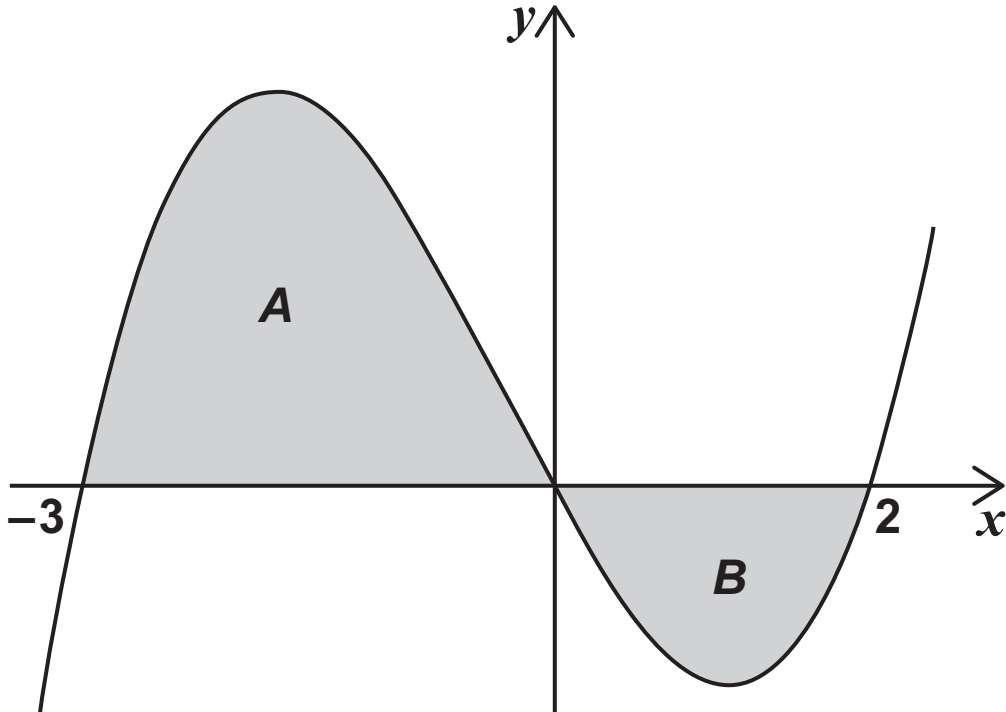

The shaded region A has an area of 189

The shaded region B has an area of 64

Find the value of $\int_{-3}^2 f(x) dx$

Circle your answer. [1 mark]

-253

-125

125

253

[Turn over]



3 Solve the inequality

$$(1 - x)(x - 4) < 0 \quad [1 \text{ mark}]$$

Tick (✓) ONE box.

$$\{x : x < 1\} \cup \{x : x > 4\}$$

$$\{x : x < 1\} \cap \{x : x > 4\}$$

$$\{x : x < 1\} \cup \{x : x \geq 4\}$$

$$\{x : x < 1\} \cap \{x : x \geq 4\}$$



[Turn over]



6 It is given that

$$(2\sin\theta + 3\cos\theta)^2 + (6\sin\theta - \cos\theta)^2 = 30$$

and that θ is obtuse.

Find the exact value of $\sin\theta$.

Fully justify your answer. [6 marks]



- 7 On the first day of each month, Kate pays £50 into a savings account.

Interest is paid on the total amount in the account on the last day of each month.

The interest rate is 0.2%

At the end of the n th month, the total amount of money in Kate's savings account is $£T_n$

Kate correctly calculates T_1 and T_2 as shown below:

$$T_1 = 50 \times 1.002 = 50.10$$

$$\begin{aligned} T_2 &= (T_1 + 50) \times 1.002 \\ &= ((50 \times 1.002) + 50) \times 1.002 \\ &= 50 \times 1.002^2 + 50 \times 1.002 \\ &\approx 100.30 \end{aligned}$$

- 7 (a) Show that T_3 is given by

$$T_3 = 50 \times 1.002^3 + 50 \times 1.002^2 + 50 \times 1.002$$

[1 mark]



7 (b) Kate uses her method to correctly calculate how much money she can expect to have in her savings account at the end of 10 YEARS.

7 (b) (i) Find the amount of money Kate expects to have in her savings account at the end of 10 YEARS.
[3 marks]

[Turn over]





- 8 A zookeeper models the median mass of infant monkeys born at their zoo, up to the age of 2 years, by the formula

$$y = a + b \log_{10} x$$

where y is the median mass in kilograms, x is age in months and a and b are constants.

The zookeeper uses the data shown below to determine the values of a and b .

Age in months (x)	3	24
Median mass (y)	6.4	12

- 8 (a) The zookeeper uses the data for monkeys aged 3 months to write the correct equation

$$6.4 = a + b \log_{10} 3$$

- 8 (a) (i) Use the data for monkeys aged 24 months to write a second equation. [1 mark]





BLANK PAGE

[Turn over]



9 (b) It is given that

$$\frac{36x}{(1 + 3x)(2 - 3x)} \equiv \frac{P}{(2 - 3x)} + \frac{Q}{(1 + 3x)}$$

where P and Q are integers.

Find the value of P and the value of Q
[3 marks]



9 (c) (i) Using your answers to parts (a) and (b), find the binomial expansion of

$$\frac{12x}{(1 + 3x)(2 - 3x)}$$

up to and including the term in x^2 [2 marks]



9 (c) (ii) Find the range of values of x for which the binomial expansion of

$$\frac{12x}{(1 + 3x)(2 - 3x)}$$

is valid. [1 mark]

[Turn over]



10 The function f is defined by

$$f(x) = x^2 + 2 \cos x \text{ for } -\pi \leq x \leq \pi$$

Determine whether the curve with equation $y = f(x)$ has a point of inflection at the point where $x = 0$

Fully justify your answer. [4 marks]



- 11 (b) The student's teacher says there is no smallest value of k in the interval $3 < k < 4$

The teacher gives the following correct proof:

Step 1: Assume there is a smallest number in the interval $3 < k < 4$ and let this smallest number be x

Step 2: let $y = \frac{3 + x}{2}$

Step 3: $3 < y < x$ which is a contradiction.

Step 4: Therefore, there is no smallest number in interval $3 < k < 4$

- 11 (b) (i) Explain the contradiction stated in Step 3
[1 mark]

[Turn over]



11 (b) (ii) Prove that there is no largest value of k in the interval $3 < k < 4$ [4 marks]



SECTION B

Answer ALL questions in the spaces provided.

- 12 Two constant forces act on a particle, of mass 2 kilograms, so that it moves forward in a straight line.

The two forces are:

- a forward driving force of 10 newtons
- a resistance force of 4 newtons.

Find the acceleration of the particle.

Circle your answer. [1 mark]

2 m s^{-2}

3 m s^{-2}

5 m s^{-2}

12 m s^{-2}



BLANK PAGE

[Turn over]



- 13 A car starting from rest moves forward in a straight line.

The motion of the car is modelled by the velocity–time graph below:

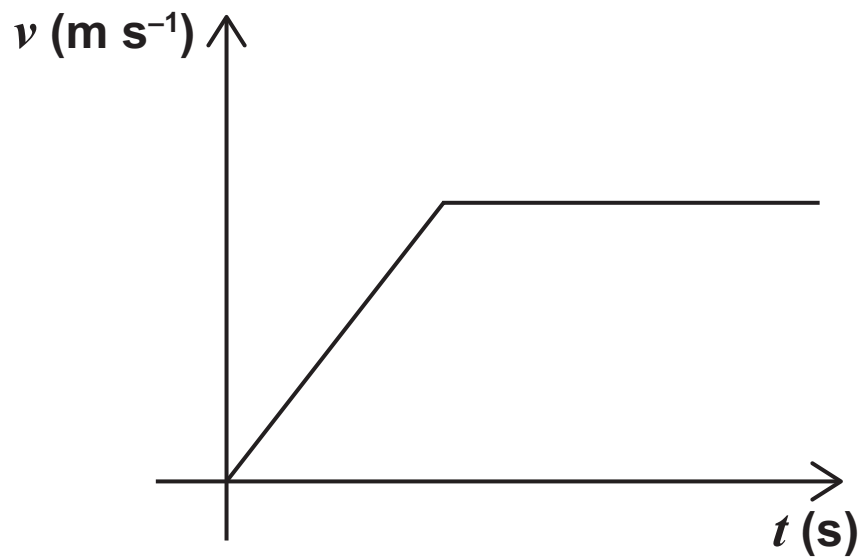

One of the following assumptions about the motion of the car is implied by the graph.

Identify this assumption. [1 mark]

Tick (✓) ONE box.

The car never accelerates.

The acceleration of the car is always positive.

The acceleration of the car can change instantaneously.

The acceleration of the car is never constant.

[Turn over]



- 14 The displacement, r metres, of a particle at time t seconds is

$$r = 6t - 2t^2$$

- 14 (a) Find the value of r when $t = 4$ [1 mark]

- 14 (b) Determine the range of values of t for which the displacement is positive. [2 marks]



BLANK PAGE

[Turn over]



16 IN THIS QUESTION USE $g = 9.8 \text{ m s}^{-2}$

An apple tree stands on horizontal ground.

An apple hangs, at rest, from a branch of the tree.

A second apple also hangs, at rest, from a different branch of the tree.

The vertical distance between the two apples is d centimetres.

At the same instant both apples begin to fall freely under gravity.

The first apple hits the ground after 0.5 seconds.

The second apple hits the ground 0.1 seconds LATER.

Show that d is approximately 54 [4 marks]



BLANK PAGE

[Turn over]



17 A uniform rod is resting on two fixed supports at points A and B .

A lies at a distance x metres from one end of the rod.

B lies at a distance $(x + 0.1)$ metres from the other end of the rod.

The rod has length $2L$ metres and mass m kilograms.

The rod lies horizontally in equilibrium as shown in the diagram below.



The reaction force of the support on the rod at B is twice the reaction force of the support on the rod at A .



BLANK PAGE

[Turn over]



18 A particle is moving in a straight line through the origin O

The displacement of the particle, r metres, from O , at time t seconds is given by

$$r = p + 2t - qe^{-0.2t}$$

where p and q are constants.

When $t = 3$, the acceleration of the particle is -1.8 m s^{-2}

18(a) Show that $q \approx 82$ [5 marks]



18 (b) The particle has an initial displacement of 5 metres.

Find the value of p

Give your answer to two significant figures.
[2 marks]



19 IN THIS QUESTION USE $g = 9.8 \text{ m s}^{-2}$

A toy shoots balls upwards with an initial velocity of 7 m s^{-1}

The advertisement for this toy claims the balls can reach a maximum height of 2.5 metres from the ground.

19 (a) Suppose that the toy shoots the balls vertically upwards.

19 (a) (i) Verify the claim in the advertisement. [2 marks]

[Turn over]



20 Two particles P and Q are moving in separate straight lines across a smooth horizontal surface.

P moves with constant velocity $(3\mathbf{i} + 4\mathbf{j}) \text{ m s}^{-1}$

Q moves from position vector $(5\mathbf{i} - 7\mathbf{j})$ metres to position vector $(14\mathbf{i} + 5\mathbf{j})$ metres during a 3 second period.

20 (a) Show that P and Q move along parallel lines.
[3 marks]



20 (c) A third particle R is moving with a constant speed of 4 m s^{-1} , in a straight line, across the same surface.

P and R move along lines that intersect at a fixed point X

It is given that:

- P passes through X exactly 2 seconds after R passes through X
- P and R are exactly 13 metres apart 3 seconds after R passes through X



BLANK PAGE

[Turn over]



21 Two heavy boxes, M and N , are connected securely by a length of rope.

The mass of M is 50 kilograms.

The mass of N is 80 kilograms.

M is placed near the bottom of a rough slope.

The slope is inclined at 60° above the horizontal.

The rope is passed over a smooth pulley at the top end of the slope so that N hangs with the rope vertical.

The boxes are initially held in this position, with the rope taut and running parallel to the line of greatest slope, as shown in the diagram below.

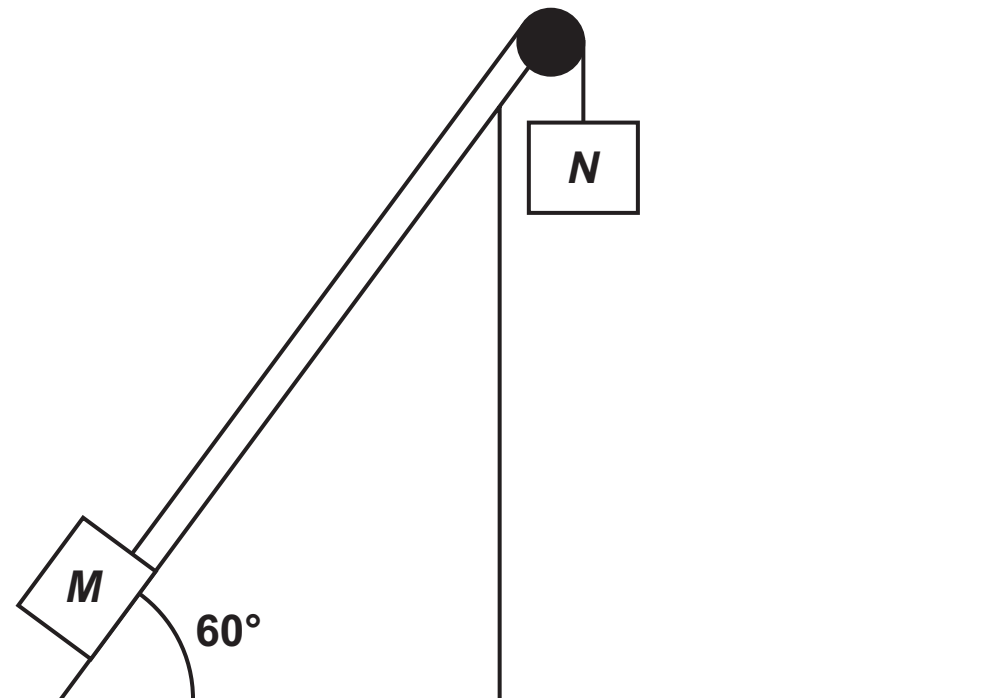

When the boxes are released, M moves up the slope as N descends, with acceleration $a \text{ m s}^{-2}$

The tension in the rope is T newtons.



21 (a) Explain why the equation of motion for N is

$$80g - T = 80a \quad [1 \text{ mark}]$$

[Turn over]



BLANK PAGE

For Examiner's Use	
Question	Mark
1	
2	
3	
4	
5	
6	
7	
8	
9	
10	
11	
12	
13	
14	
15	
16	
17	
18	
19	
20	
21	
TOTAL	

Copyright information

For confidentiality purposes, all acknowledgements of third-party copyright material are published in a separate booklet. This booklet is published after each live examination series and is available for free download from www.aqa.org.uk.

Permission to reproduce all copyright material has been applied for. In some cases, efforts to contact copyright-holders may have been unsuccessful and AQA will be happy to rectify any omissions of acknowledgements. If you have any queries please contact the Copyright Team.

Copyright © 2024 AQA and its licensors. All rights reserved.

G/LM/Jun24/7357/2/G4005/E3



7 0



2 4 6 A 7 3 5 7 / 2