



**Surname** \_\_\_\_\_

**Forename(s)** \_\_\_\_\_

**Centre Number** \_\_\_\_\_

**Candidate Number** \_\_\_\_\_

**Candidate Signature** \_\_\_\_\_

**I declare this is my own work.**

**A-level**

**PHYSICS**

**Paper 3**

**Section B Engineering physics**

**7408/3BC**

**Thursday 15 June 2023**

**Morning**

**At the top of the page, write your surname and forename(s), your centre number, your candidate number and add your signature.**

**[Turn over]**



**Time allowed:** The total time for both sections of this paper is 2 hours. You are advised to spend approximately 50 minutes on this section.

### **MATERIALS**

**For this paper you must have:**

- a pencil and a ruler
- a scientific calculator
- a Data and Formulae Booklet
- a protractor.

### **INSTRUCTIONS**

- Use black ink or black ball-point pen.
- Answer ALL questions.
- You must answer the questions in the spaces provided. Do not write on blank pages.
- If you need extra space for your answer(s), use the lined pages at the end of this book. Write the question number against your answer(s).
- Do all rough work in this book. Cross through any work you do not want to be marked.
- Show all your working.



## **INFORMATION**

- **The marks for questions are shown in brackets.**
- **The maximum mark for this paper is 35.**
- **You are expected to use a scientific calculator where appropriate.**
- **A Data and Formulae Booklet is provided as a loose insert.**

**DO NOT TURN OVER UNTIL TOLD TO DO SO**



**BLANK PAGE**



**SECTION B**

**Answer ALL questions in this section.**

**0 1 . 1**

**One equation used in translational dynamics is:**

**force = mass × acceleration**

**State IN WORDS the equivalent equation used in rotational dynamics. [2 marks]**

---

---

---

**[Turn over]**



**FIGURE 1** shows two identical uniform plates A and B. The axis of rotation of each plate is shown.

**FIGURE 1**

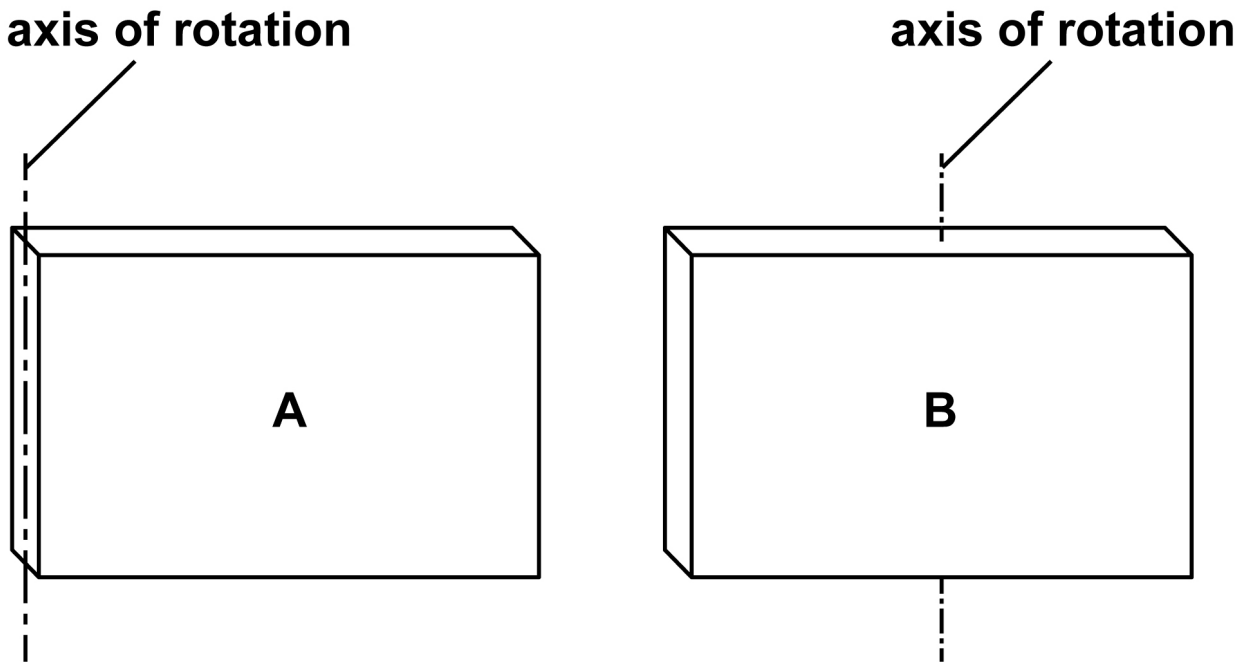

0	1	.	2
---	---	---	---

**State and explain which plate has the greater moment of inertia about its axis of rotation. [2 marks]**

---

---

---

---

---

---

---

---

---

---

---

---

**[Turn over]**



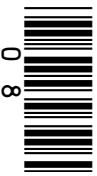

An electric motor drives a machine that punches out plates from a long strip of sheet metal. The motor runs continuously and is fitted with a flywheel. FIGURE 2 shows how the angular velocity  $\omega$  of the flywheel varies with time  $t$ .

FIGURE 2

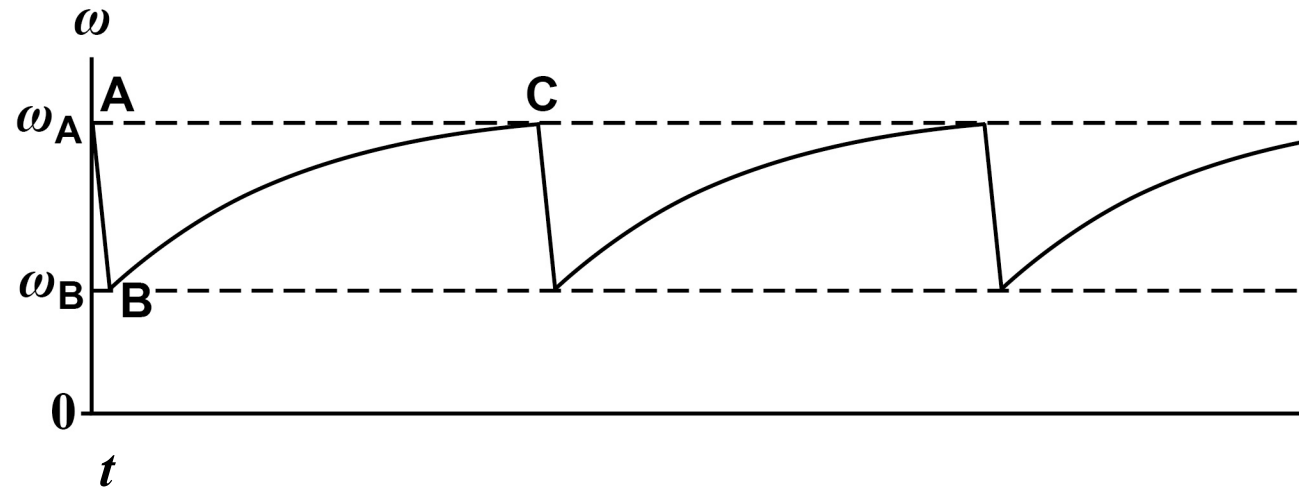

∞

TABLE 1 describes the sequence for the machine after it has been brought up to speed  $\omega_A$ .

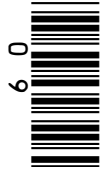

**TABLE 1**

<b>A</b>	<b>The punching operation starts.</b>
<b>A to B</b>	<b>The flywheel transfers some of its energy during the punching operation.</b>
<b>B to C</b>	<b>The flywheel is again brought up to speed <math>\omega_A</math> by the motor.</b>
<b>C</b>	<b>The next punching operation starts.</b>

**0 1 . 3**

**6**

**A new flywheel with a greater moment of inertia is fitted in place of the original flywheel. The motor torque is constant and the same as before.**

**Sketch on FIGURE 2, on page 6, a graph showing how the angular velocity varies with time for the machine fitted with the new flywheel.**

**Assume that:**

- the punching operation starts at the same angular speed  $\omega_A$**
- the same quantity of energy is transferred when punching the metal sheet.**

**[2 marks]**

**[Turn over]**

**BLANK PAGE**



0	1	.	4
---	---	---	---

**Explain ONE difference between your graph and the original graph. [1 mark]**

---

---

---

---

---

---

---

---

---

---

**[Turn over]**

7



02

**FIGURE 3** shows a heavy stone grinding wheel used for sharpening tools.

**FIGURE 3**

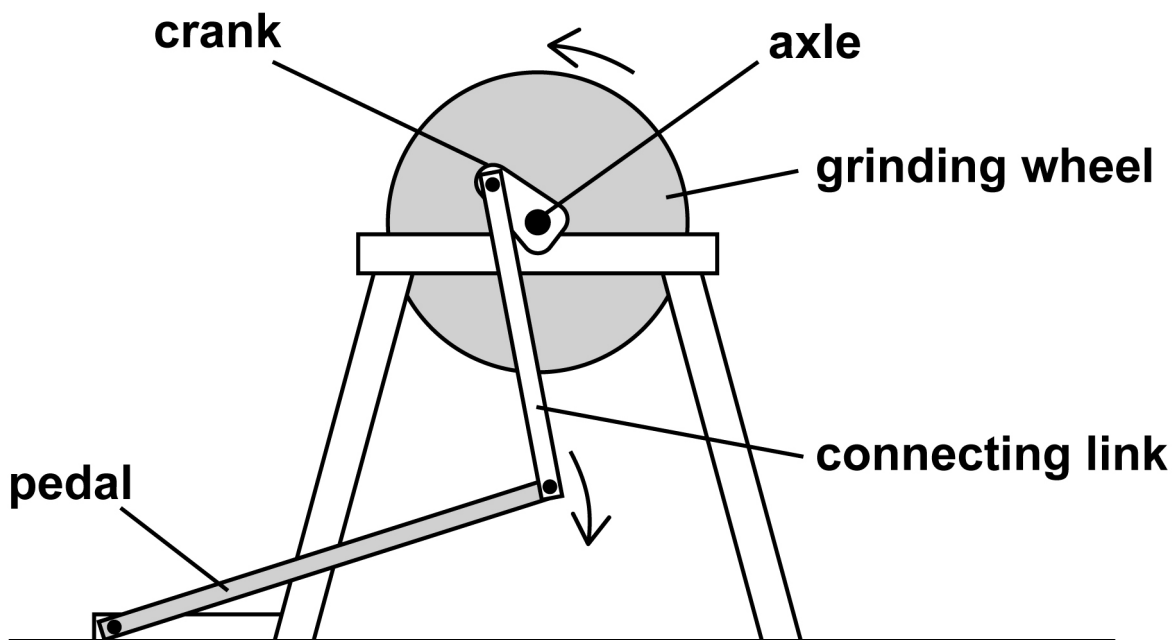

The pedal is connected to the axle of the wheel by a connecting link and crank.

The operator pushes the pedal downwards to accelerate the wheel from rest.

The wheel begins to rotate in the direction shown.







0	2	.	3
---	---	---	---

The connecting link breaks. At this instant the angular speed of the wheel is  $13.8 \text{ rad s}^{-1}$ .

It takes  $15.0 \text{ s}$  for the wheel to come to rest.

The frictional torque acting at the axle bearings is  $0.77 \text{ N m}$  and is constant for all speeds.

Calculate the moment of inertia of the wheel. [2 marks]

moment of inertia = \_\_\_\_\_  $\text{kg m}^2$

[Turn over]



The arrangement is modified as shown in FIGURE 4. The pedal, connecting link and crank are removed and the grinding wheel is driven by an electric motor.

FIGURE 4

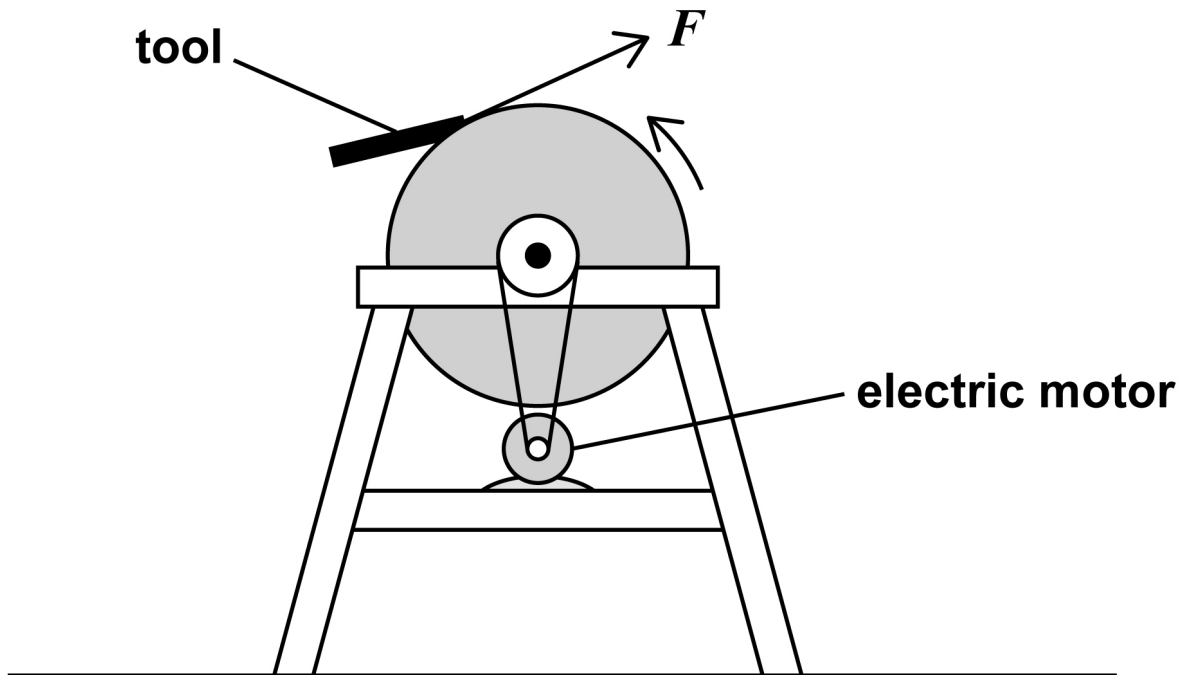

0	2	.	4
---	---	---	---

**FIGURE 4** also shows a tool being sharpened by pressing it on the edge of the rotating wheel.

The tool applies a tangential force  $F$  on the wheel.

A torque of  $3.10 \text{ N m}$  is needed at the axle to drive the wheel at constant angular speed while the tool is being sharpened.

frictional torque at the axle bearings =  $0.77 \text{ N m}$

radius of wheel =  $0.24 \text{ m}$

Calculate  $F$ . [2 marks]

$F =$  \_\_\_\_\_ **N**

[Turn over]



02.5

Three motors E, F and G were available to drive the wheel in FIGURE 4, on page 16.

FIGURE 5, below and on page 19, shows how the torque  $T$  varies with angular speed  $\omega$  for each motor.

FIGURE 5

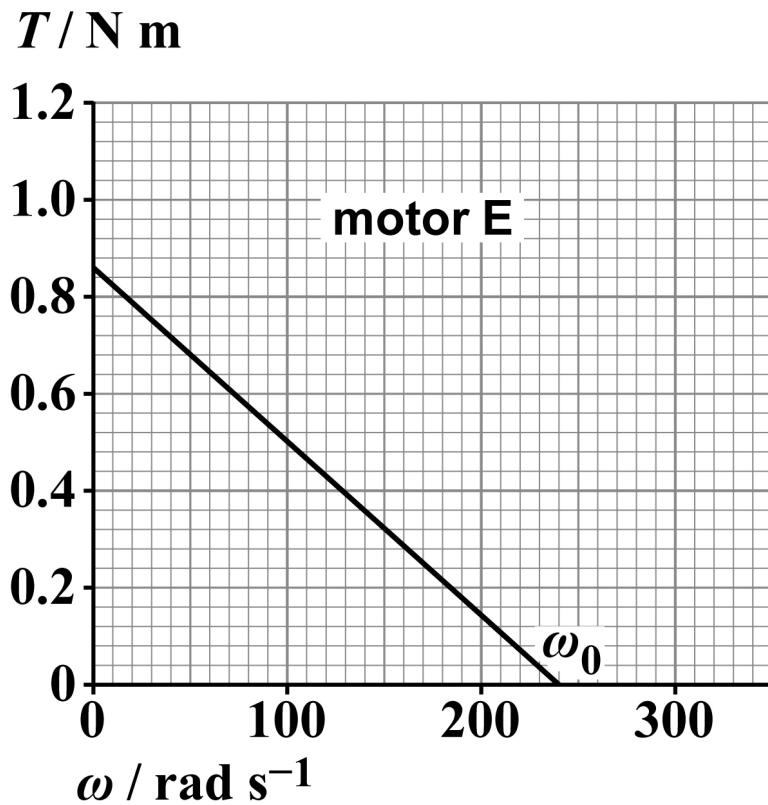

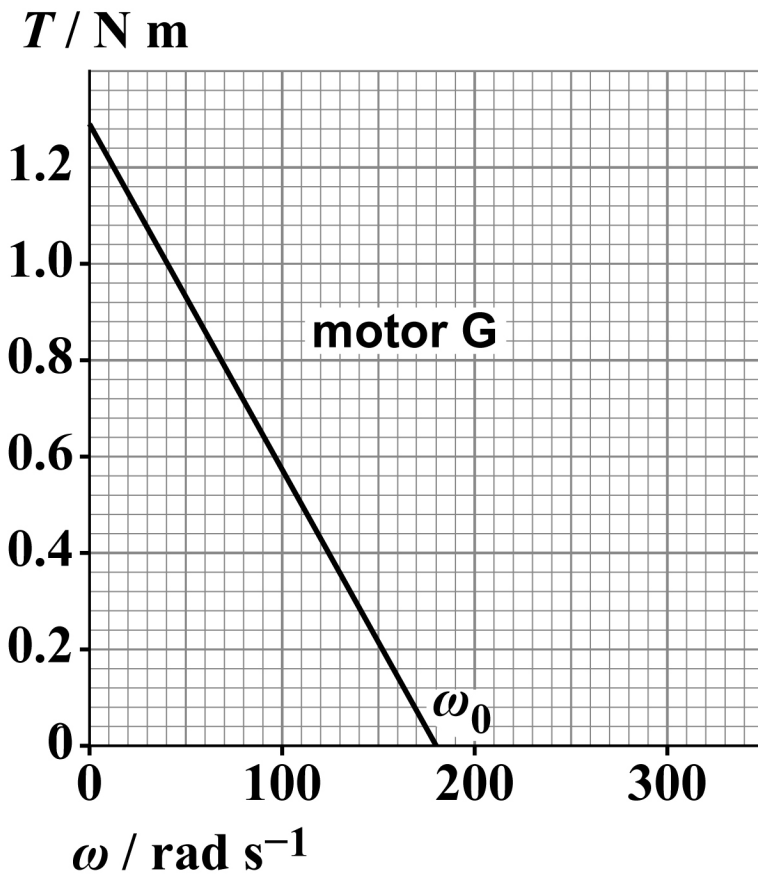
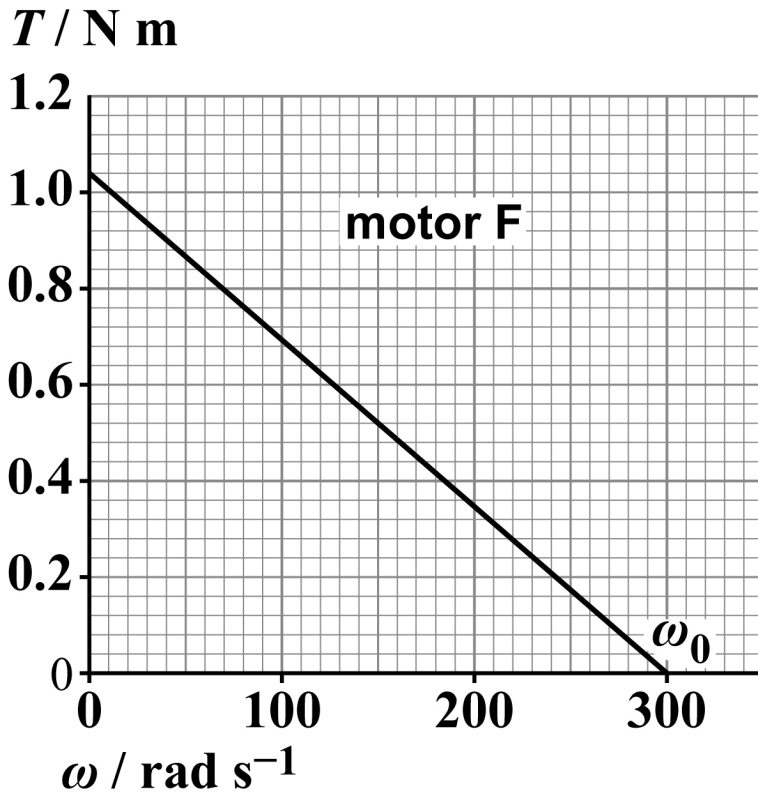

[Turn over]



The no-load speed  $\omega_0$  is the angular speed of a motor when the torque applied is zero.

The maximum power of each motor is developed at about  $0.5\omega_0$ .

The required output power of the motor when a tool is being sharpened is 52 W.

The required output power of the chosen motor should be about  $\frac{2}{3}$  of its maximum power.

Deduce which motor E, F or G was chosen for this application. [3 marks]



---

---

---

---

---

**[Turn over]**

<hr/>
<b>11</b>



03.1

The first law of thermodynamics can be written as:

$$Q = \Delta U + W$$

State what  $Q$  represents in this equation. [1 mark]

---

---

---

Air in the brake pipe of a bicycle hydraulic brake system can be dangerous.

FIGURE 6 shows a bubble of air in a brake pipe.

FIGURE 6

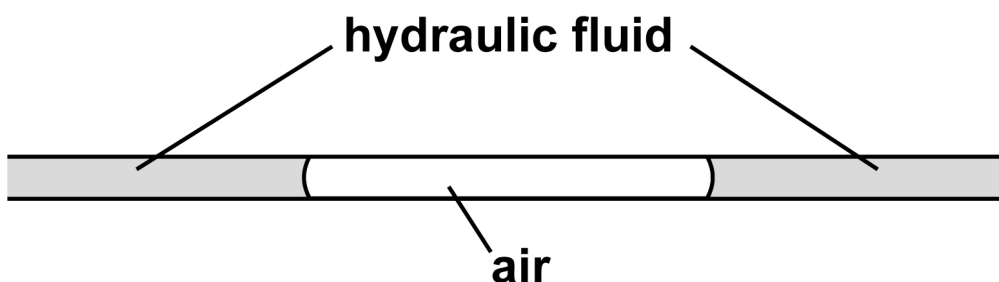

Assume that the hydraulic fluid is incompressible. During a sudden application of the brake, the air is compressed adiabatically to a high pressure.

03.2

The work done on the air when it is compressed is 10.8 mJ.

Which row is correct for this adiabatic compression?  
[1 mark]

Tick (✓) ONE box.

	$W / \text{mJ}$	$Q / \text{mJ}$	$\Delta U / \text{mJ}$
<input type="checkbox"/>	-10.8	0	10.8
<input type="checkbox"/>	10.8	10.8	0
<input type="checkbox"/>	-10.8	-10.8	0
<input type="checkbox"/>	10.8	0	-10.8

[Turn over]



0	3	.	3
---	---	---	---

The initial conditions for the air are:

volume of air =  $2.91 \times 10^{-8} \text{ m}^3$

pressure of air =  $1.05 \times 10^5 \text{ Pa}$

temperature of air = 293 K.

During sudden braking, the air in the bubble is compressed adiabatically to a volume of  $3.19 \times 10^{-9} \text{ m}^3$ .

Calculate the pressure and the temperature of the air immediately after the compression.

$\gamma$  for air = 1.4 [3 marks]



pressure = \_\_\_\_\_ Pa

temperature = \_\_\_\_\_ K

[Turn over]





---

---

---

---

[Turn over]

7



04

FIGURE 7 shows the  $p-V$  diagram for a theoretical diesel engine cycle.

FIGURE 8, on the opposite page, shows the indicator diagram for a real four-stroke diesel engine working between the same maximum and minimum volumes.

FIGURE 7

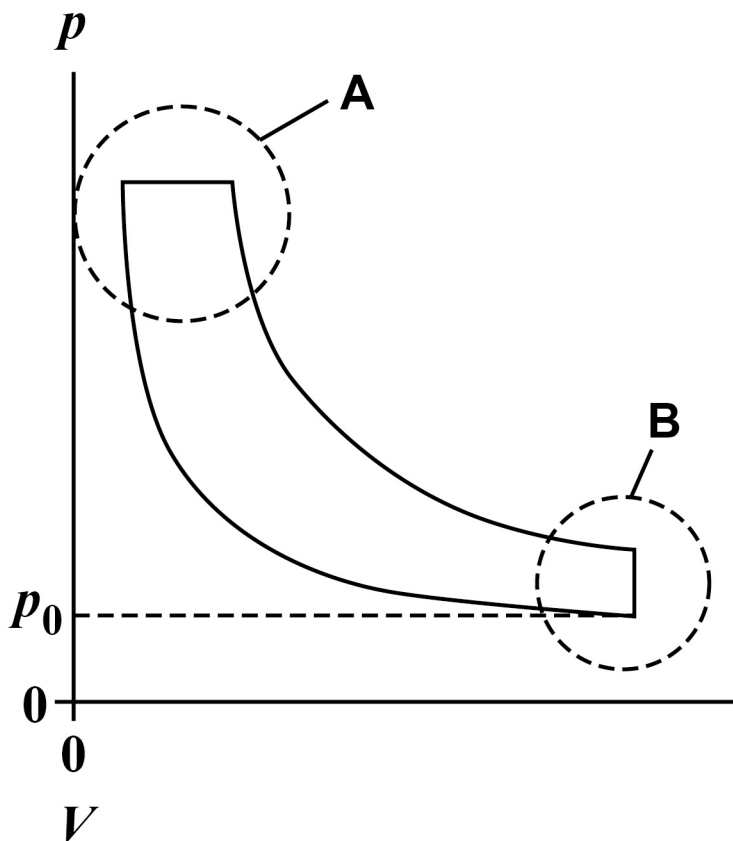
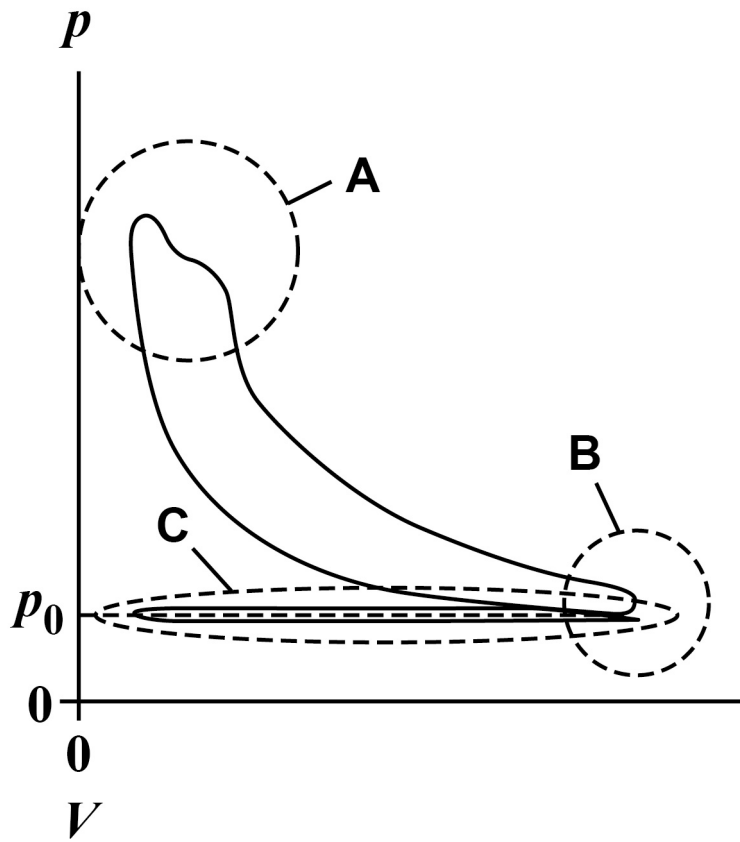

FIGURE 8



[Turn over]



BLANK PAGE



$p_0$  is atmospheric pressure.

Compare the indicator diagram with the theoretical diesel cycle.

In your answer, explain:

- the differences between region A on FIGURE 7 and region A on FIGURE 8
- the differences between region B on FIGURE 7 and region B on FIGURE 8
- why the features shown in region C appear only on the indicator diagram
- why the efficiency of the real engine will always be less than the efficiency predicted by an analysis of the theoretical cycle.

[6 marks]

---

---

---

---

---

---

[Turn over]









---

---

---

---

---

---

---

[Turn over]

6



05

FIGURE 9 shows an ideal heat engine.

FIGURE 9

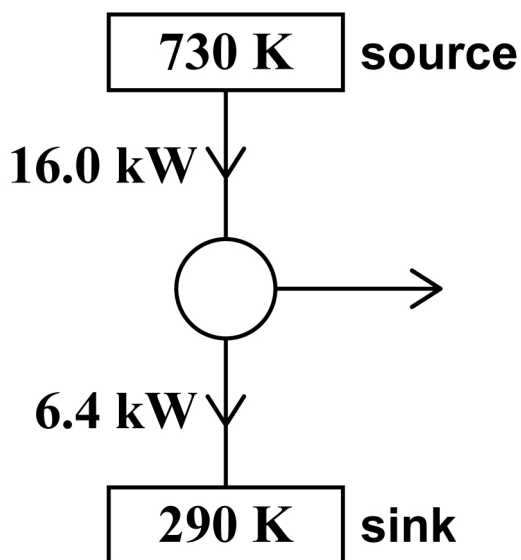

The engine operates between a source at a temperature of 730 K and a sink at a temperature of 290 K.

The input power is 16.0 kW and the power rejected to the sink is 6.4 kW.

0	5	.	1
---	---	---	---

Calculate the efficiency of this engine. [1 mark]

efficiency = \_\_\_\_\_

[Turn over]



05.2

FIGURE 10 shows another system operating between the same overall temperatures and with the same input power as the engine in FIGURE 9, on page 36. This system consists of two ideal engines.

FIGURE 10

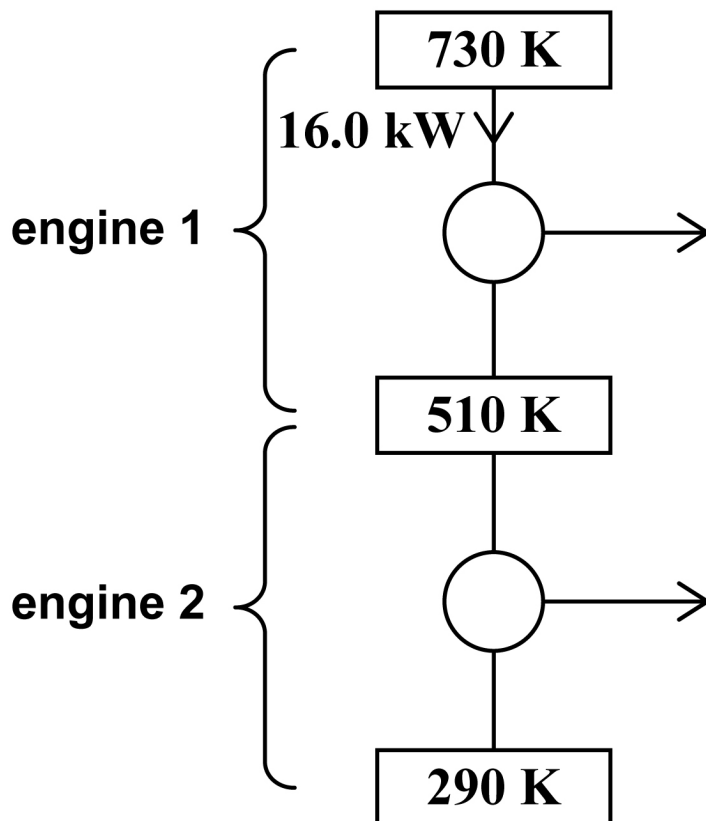



---

---

---

---

**END OF QUESTIONS**

<hr/>
4





**BLANK PAGE**

For Examiner's Use	
Question	Mark
1	
2	
3	
4	
5	
<b>TOTAL</b>	

**Copyright information**

For confidentiality purposes, all acknowledgements of third-party copyright material are published in a separate booklet. This booklet is published after each live examination series and is available for free download from [www.aqa.org.uk](http://www.aqa.org.uk).

Permission to reproduce all copyright material has been applied for. In some cases, efforts to contact copyright-holders may have been unsuccessful and AQA will be happy to rectify any omissions of acknowledgements. If you have any queries please contact the Copyright Team.

Copyright © 2023 AQA and its licensors. All rights reserved.

**WP/M/MW/Jun23/7408/3BC/E4**