



Surname _____

Other Names _____

Centre Number _____

Candidate Number _____

Candidate Signature _____

I declare this is my own work.

GCSE

COMBINED SCIENCE: SYNERGY

H

8465/3H

Higher Tier

Paper 3 Physical Sciences

Time allowed: 1 hour 45 minutes

At the top of the page, write your surname and other names, your centre number, your candidate number and add your signature.

[Turn over]



MATERIALS

For this paper you must have:

- **a ruler**
- **a protractor**
- **a scientific calculator**
- **the periodic table (enclosed)**
- **the Physics Equations Sheet (enclosed).**

INSTRUCTIONS

- **Use black ink or black ball-point pen. Pencil should only be used for drawing.**
- **Answer ALL questions in the spaces provided. Do not write on blank pages.**
- **If you need extra space for your answer(s), use the lined pages at the end of this book. Write the question number against your answer(s).**
- **Do all rough work in this book. Cross through any work you do not want to be marked.**
- **In all calculations, show clearly how you work out your answer.**



INFORMATION

- **The maximum mark for this paper is 100.**
- **The marks for questions are shown in brackets.**
- **You are expected to use a calculator where appropriate.**
- **You are reminded of the need for good English and clear presentation in your answers.**

**DO NOT TURN OVER UNTIL TOLD
TO DO SO**



0	1
---	---

This question is about structure and bonding.

0	1	.	1
---	---	---	---

Why can metals be shaped? [1 mark]

Tick (✓) ONE box.

Different-sized atoms distort the structure.

Layers of atoms slide over each other.

Metallic bonds are weak.

Metals have low melting points.



01.3

FIGURE 1 represents the structure of diamond and of sodium chloride.

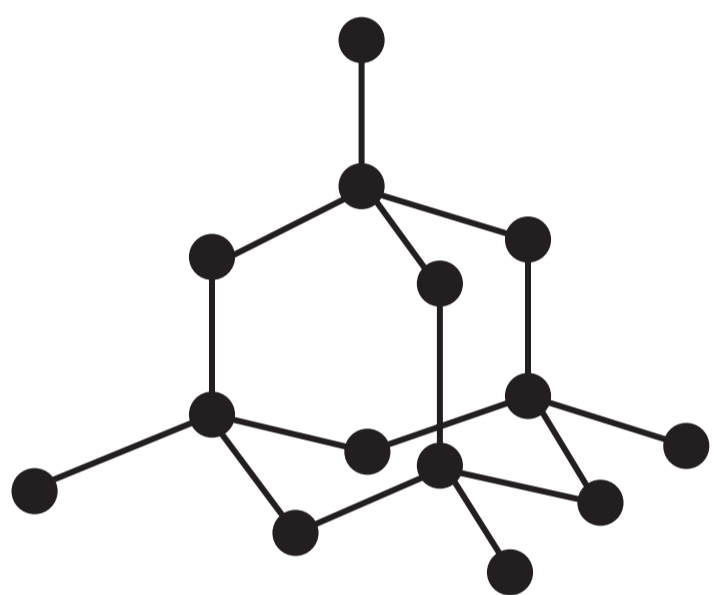
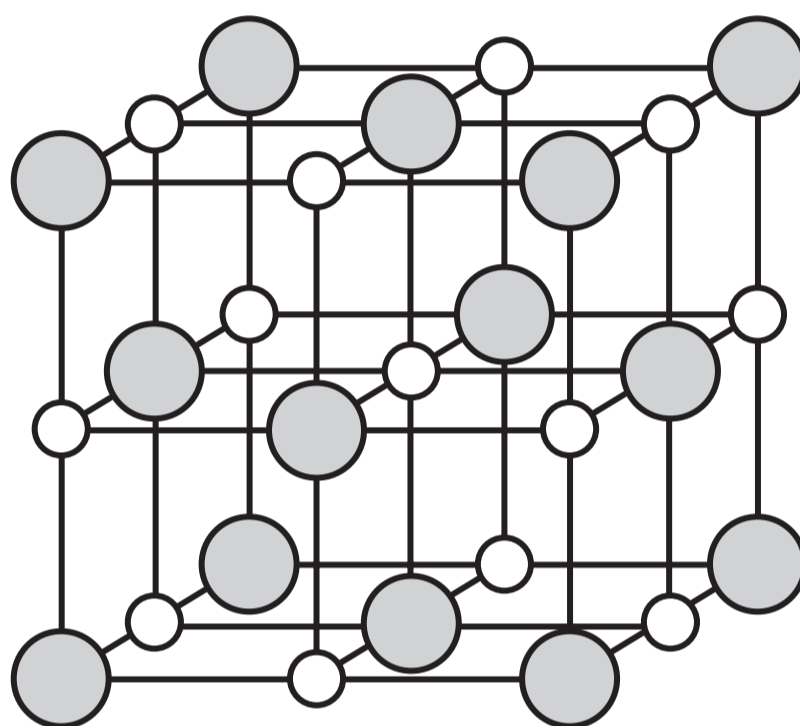
FIGURE 1**DIAMOND****SODIUM CHLORIDE****KEY**

● C atom ○ Na⁺ ion ● Cl⁻ ion





Ethene (C_2H_4) is a small molecule.

0 1 . 4

Calculate the relative formula mass (M_r) of ethene. [2 marks]

Relative atomic masses (A_r):

C = 12 H = 1

Relative formula mass = _____

[Turn over]



BLANK PAGE

[Turn over]



0 2

FIGURE 2 shows a boat on the sea.

FIGURE 2

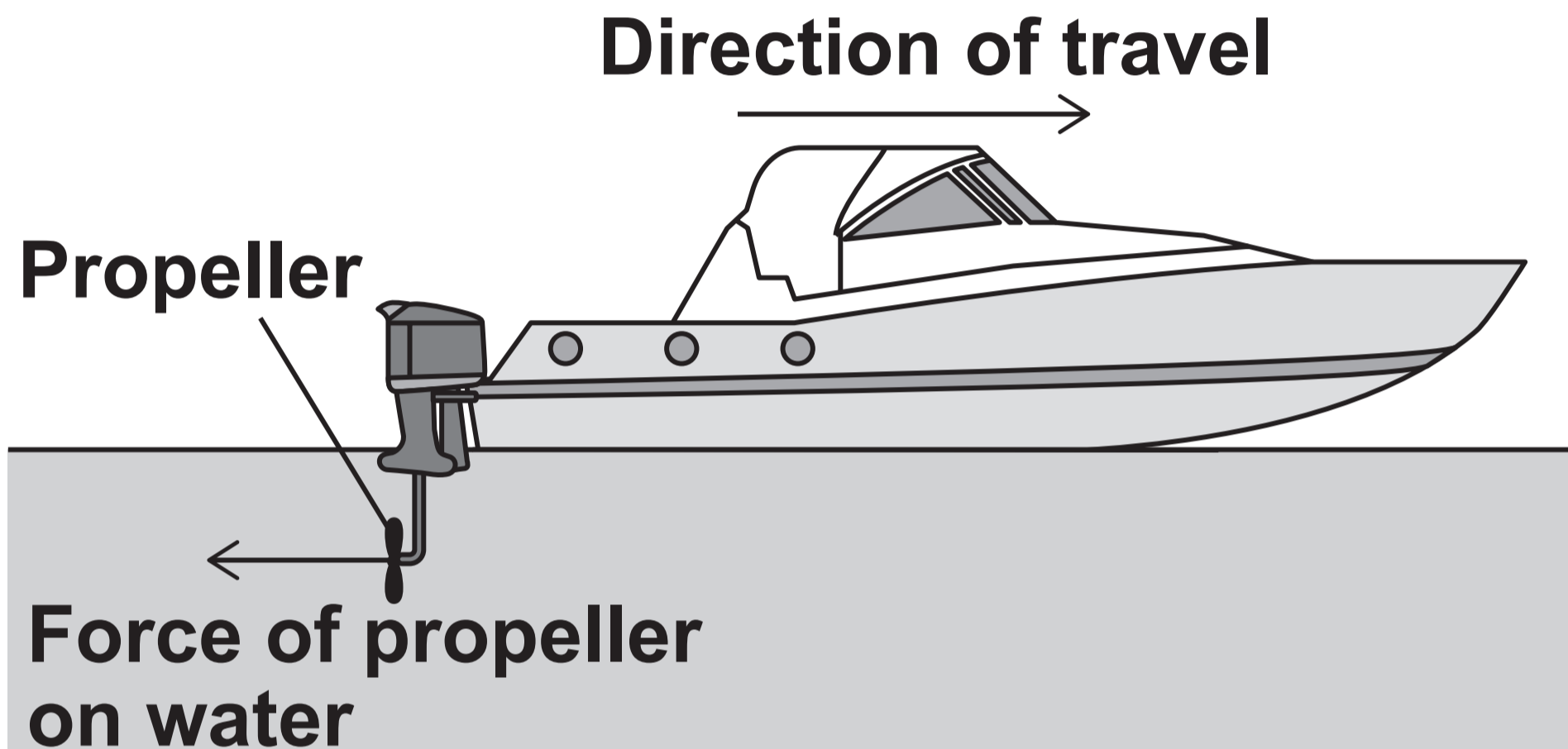

The boat is travelling at a constant speed.

0 2 . 1

Draw an arrow on FIGURE 2 to show the size and direction of the force of the water on the propeller. [2 marks]



0 2 . 2

A quantity can be a scalar quantity or a vector quantity.

Identify which quantities are scalar quantities and which quantities are vector quantities. [2 marks]

Tick (✓) ONE box in EACH row.

QUANTITY	SCALAR	VECTOR
Speed		
Velocity		
Mass		
Weight		

[Turn over]



0	2	.	3
---	---	---	---

Which equation links distance (s), speed (v) and time (t)? [1 mark]

Tick (✓) ONE box.

$$s = \frac{v}{t}$$

$$s = \frac{t}{v}$$

$$v = \frac{s}{t}$$

$$v = s \times t$$



0 2 . 5

FIGURE 3 shows the forces acting on the boat when it is moving at a constant speed.

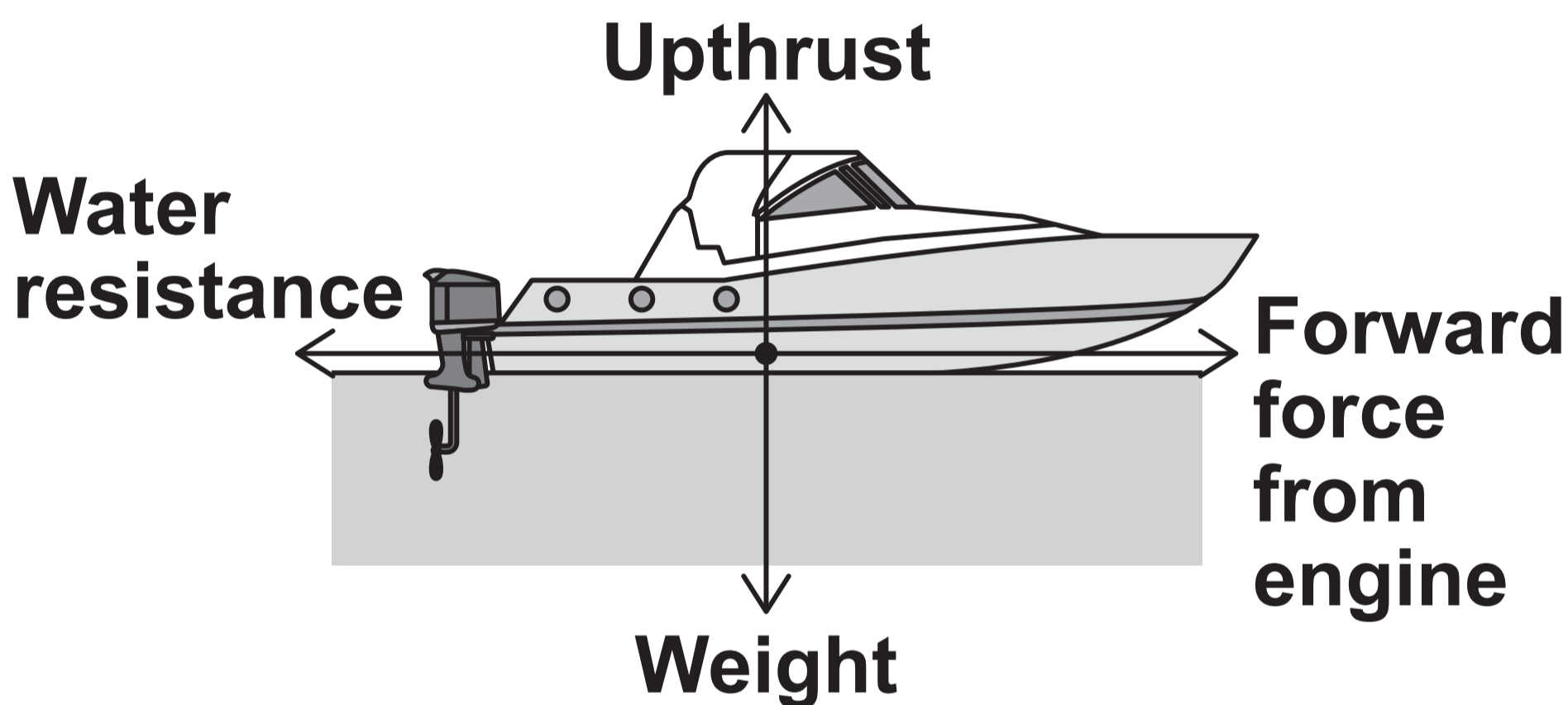
FIGURE 3

The engine of the boat is turned off. The boat slows down and stops.





BLANK PAGE

[Turn over]



0	3
---	---

Calcium carbonate reacts with hydrochloric acid.

The equation for the reaction is:

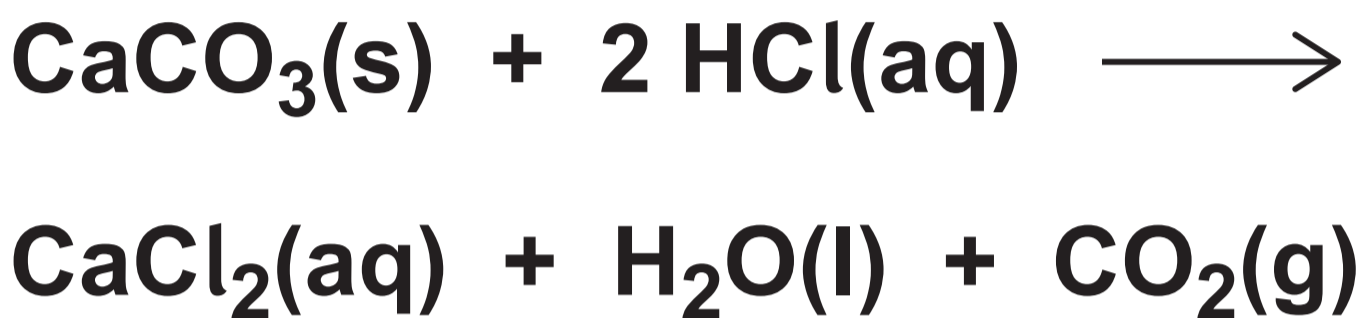

A student investigated the effect of changing the surface area of the calcium carbonate on the rate of this reaction.

The student used calcium carbonate in the form of lumps and of powder.



FIGURE 4 shows the apparatus.

FIGURE 4

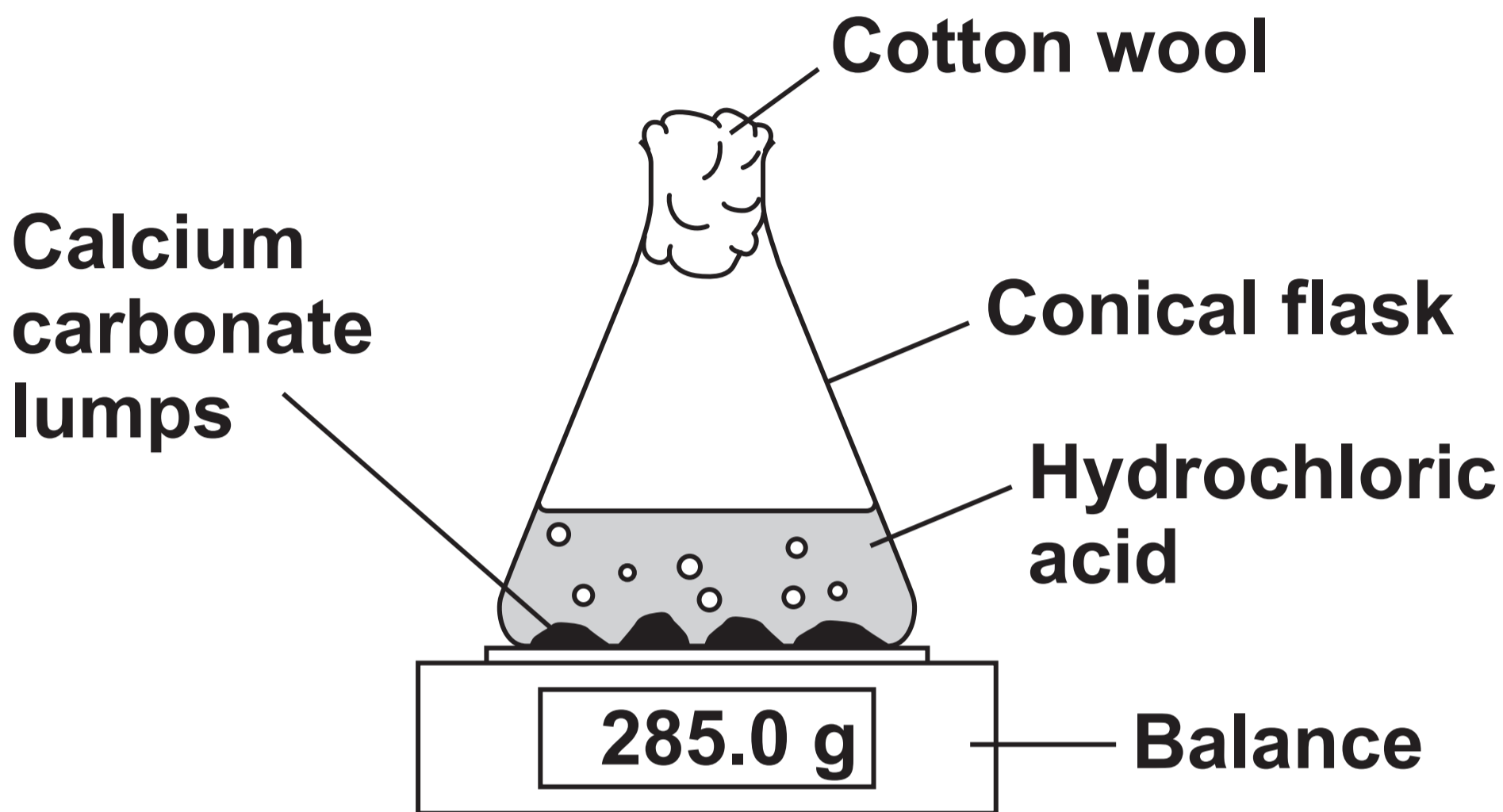

The rate of reaction is determined by measuring the decrease in mass of the conical flask and contents at regular time intervals.

[Turn over]



0	3	.	1
---	---	---	---

Give the reason why the mass of the conical flask and contents decreases. [1 mark]

0	3	.	2
---	---	---	---

The mean rate of reaction using the calcium carbonate lumps was 0.0012 g/s.

Calculate the time taken for the mass of the conical flask and contents to decrease by 0.36 g. [3 marks]



Time taken = _____ s

[Turn over]



The surface area of a calcium carbonate lump can be estimated by comparing the lump with a cube.

FIGURE 5 shows a cube and a similar-sized calcium carbonate lump.

FIGURE 5

CUBE

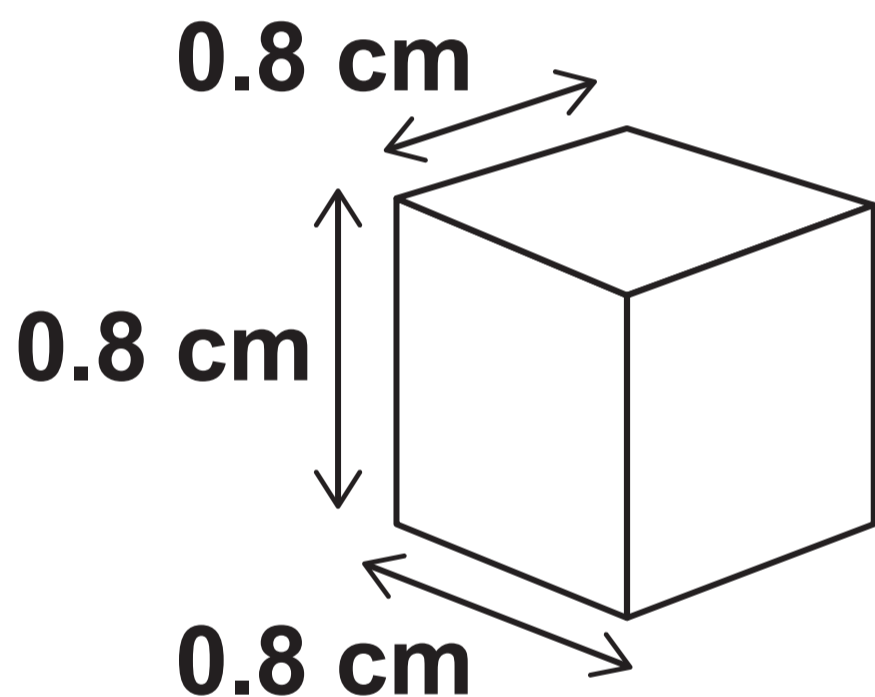

LUMP

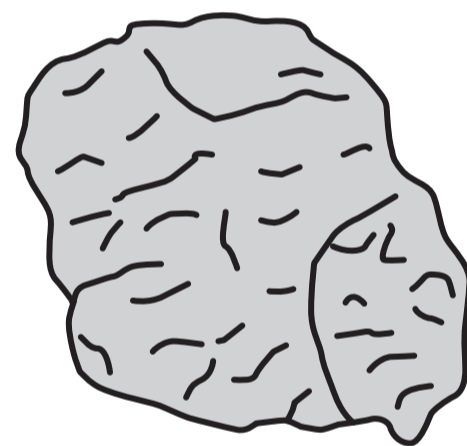

[Turn over]



0	3	.	4
---	---	---	---

Calculate the total surface area of the cube in FIGURE 5 on page 25. [3 marks]

Total surface area = _____ cm²



0	3	.	5
---	---	---	---

The total surface area of the calcium carbonate lump in FIGURE 5 is estimated rather than measured.

Suggest ONE reason why. [1 mark]

11

[Turn over]



04

Hydrogen reacts with oxygen to produce water.

FIGURE 6 represents the equation for the reaction.

FIGURE 6



TABLE 1 shows bond energies.

TABLE 1

BOND	Bond energy in kJ/mol
H—H	436
O=O	498
O—H	464



0	4	.	1
---	---	---	---

Calculate the energy released during bond formation in the reaction.

Use FIGURE 6 and TABLE 1, on the opposite page. [2 marks]

Energy released = _____ kJ/mol

[Turn over]



04.2

In the reaction to produce water, the energy needed to break bonds is less than the energy released when bonds are formed.

Which reaction profile represents this reaction? [1 mark]

Tick (✓) ONE box.

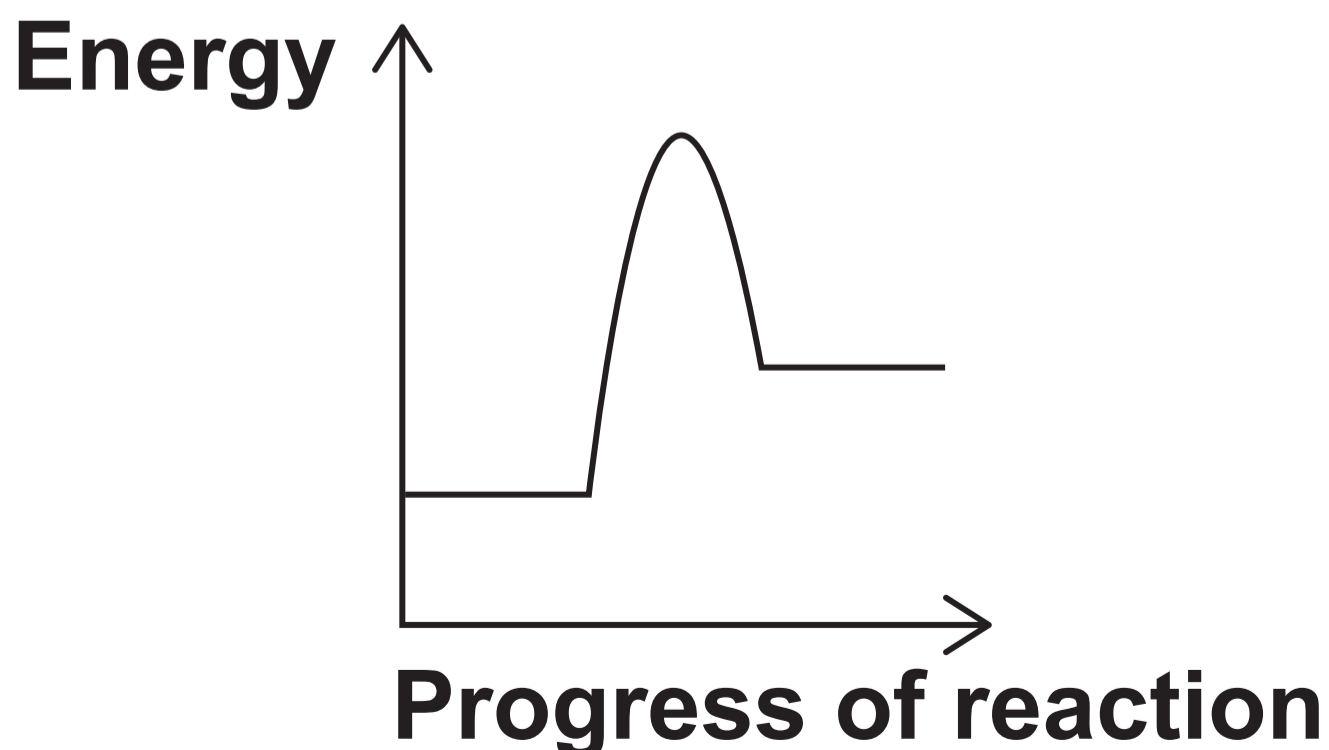
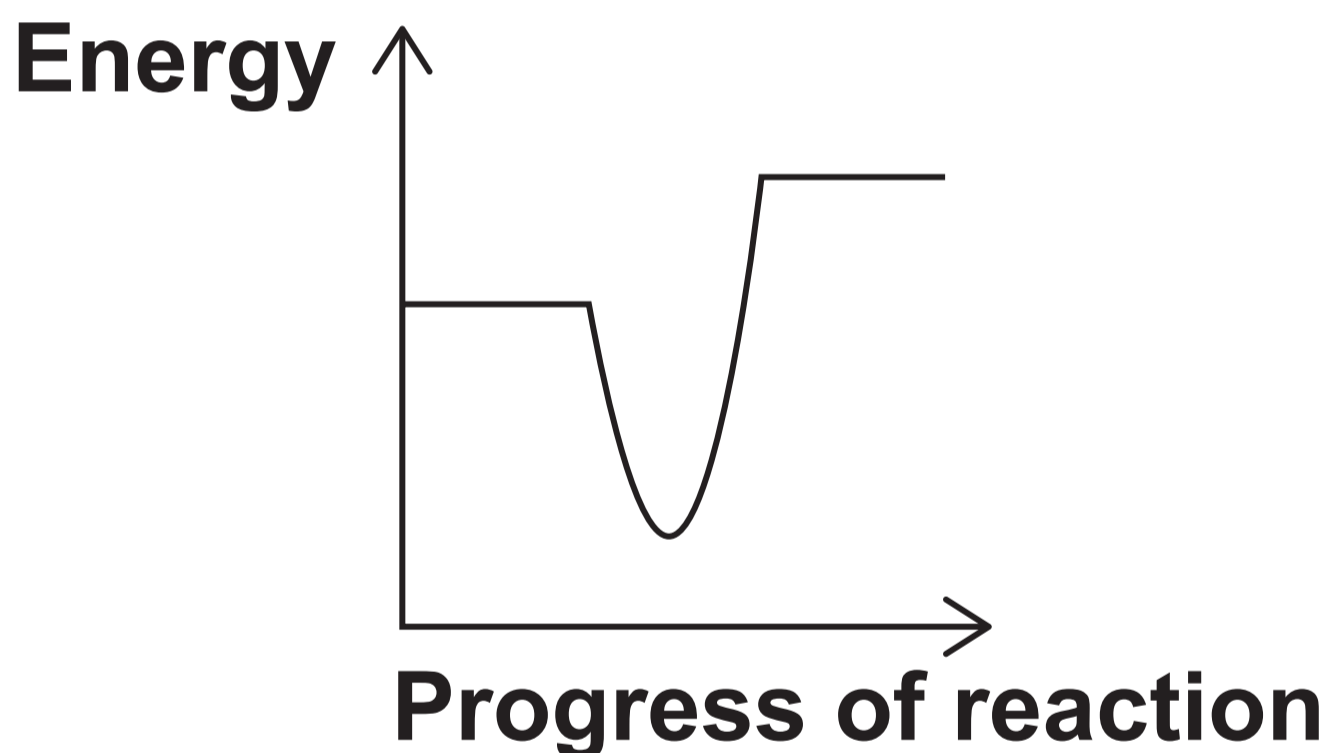

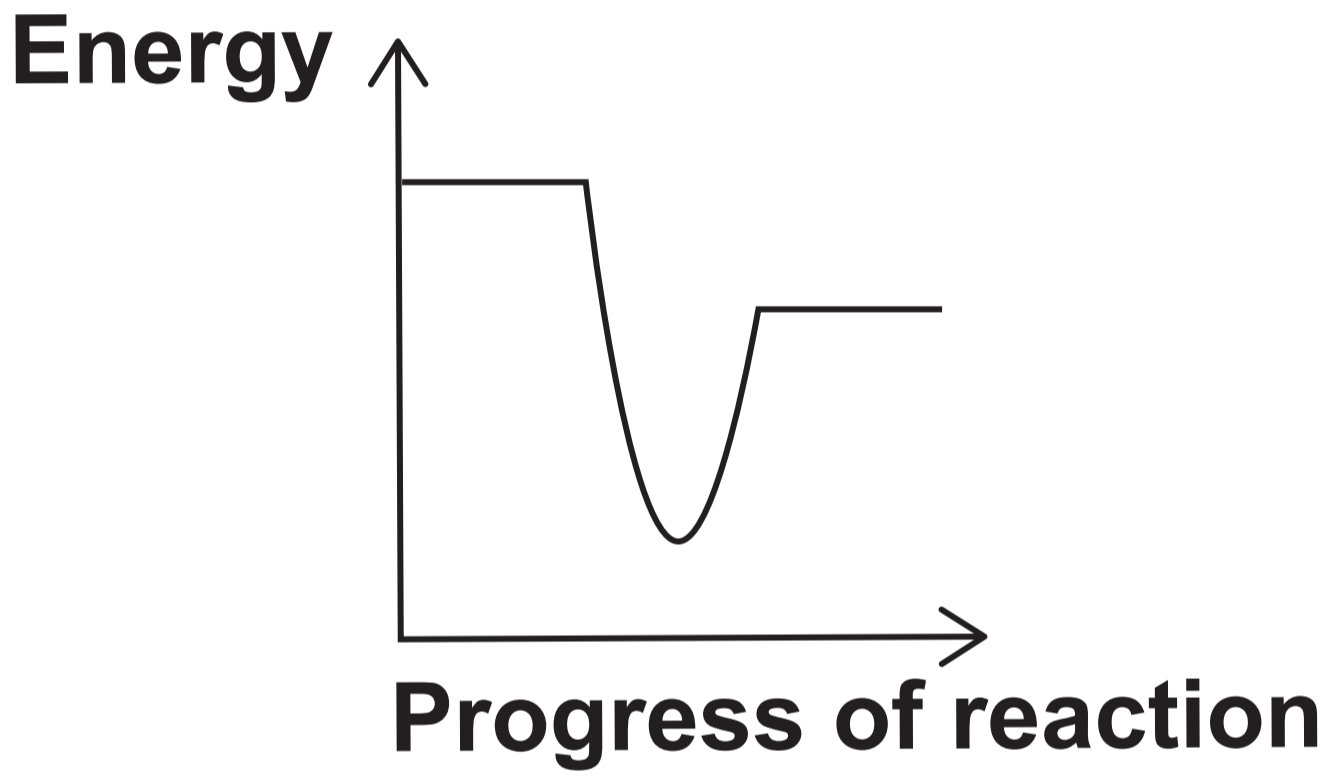
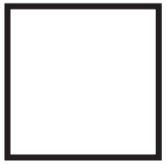
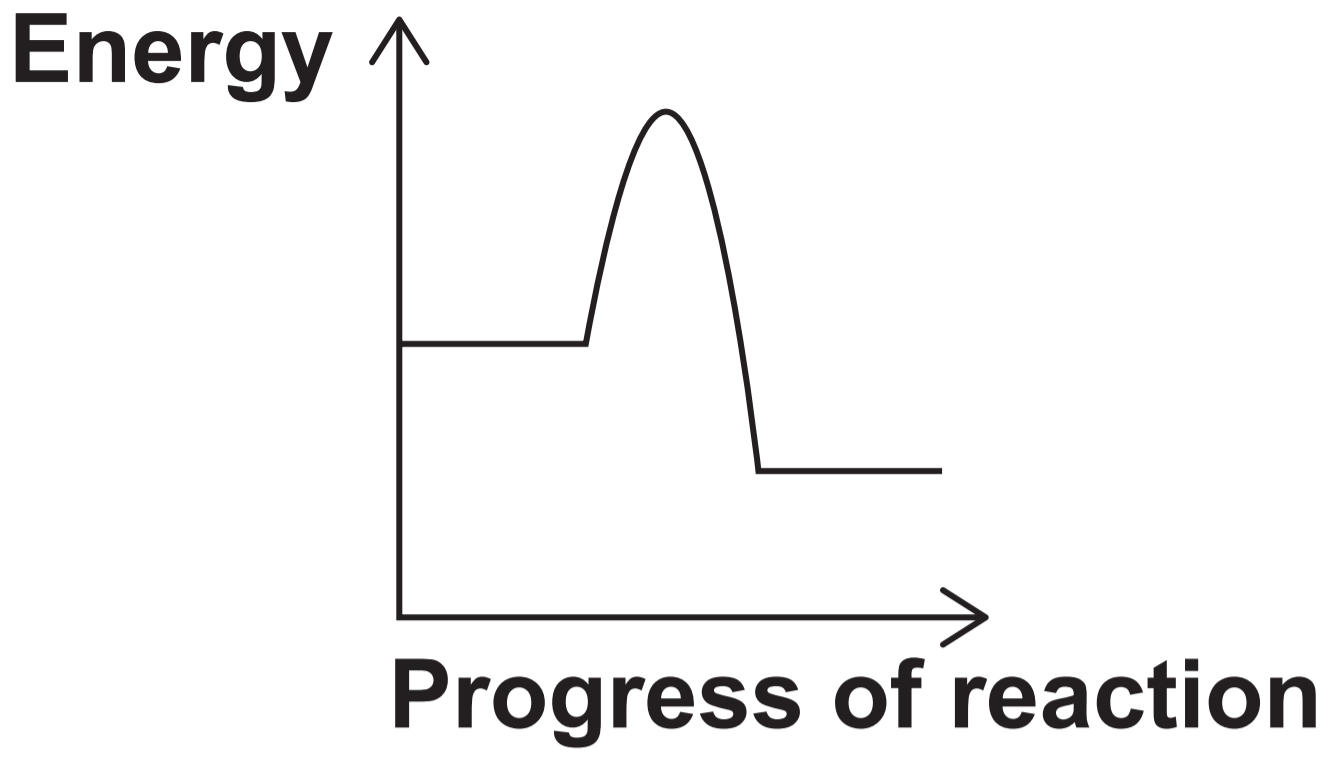
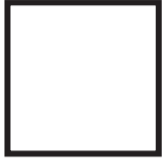

[Turn over]



0	4	.	3
---	---	---	---

Complete the dot and cross diagram for a water molecule. [2 marks]

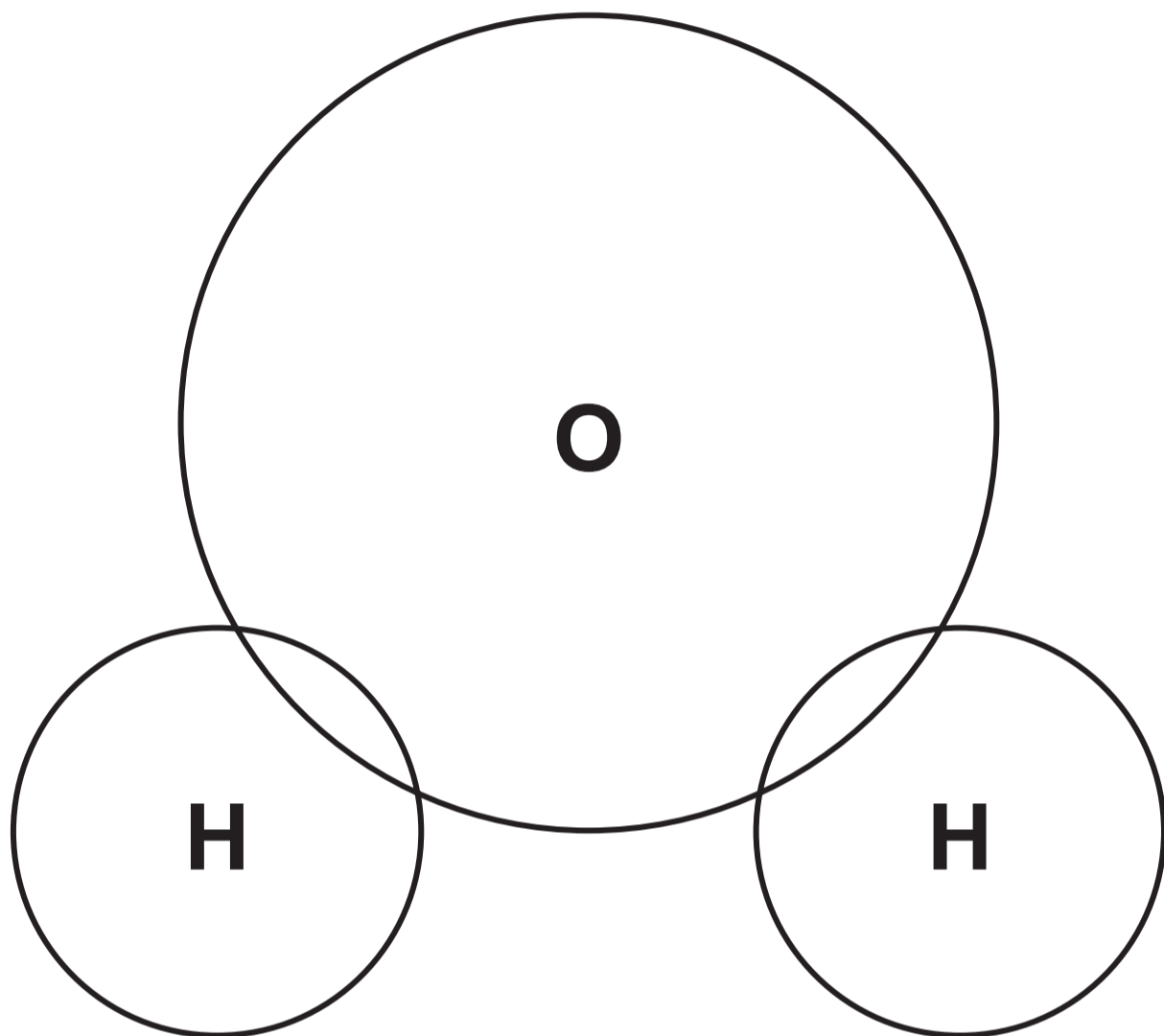

0 5

FIGURE 7 shows a student driving a bumper car at a theme park.

FIGURE 7

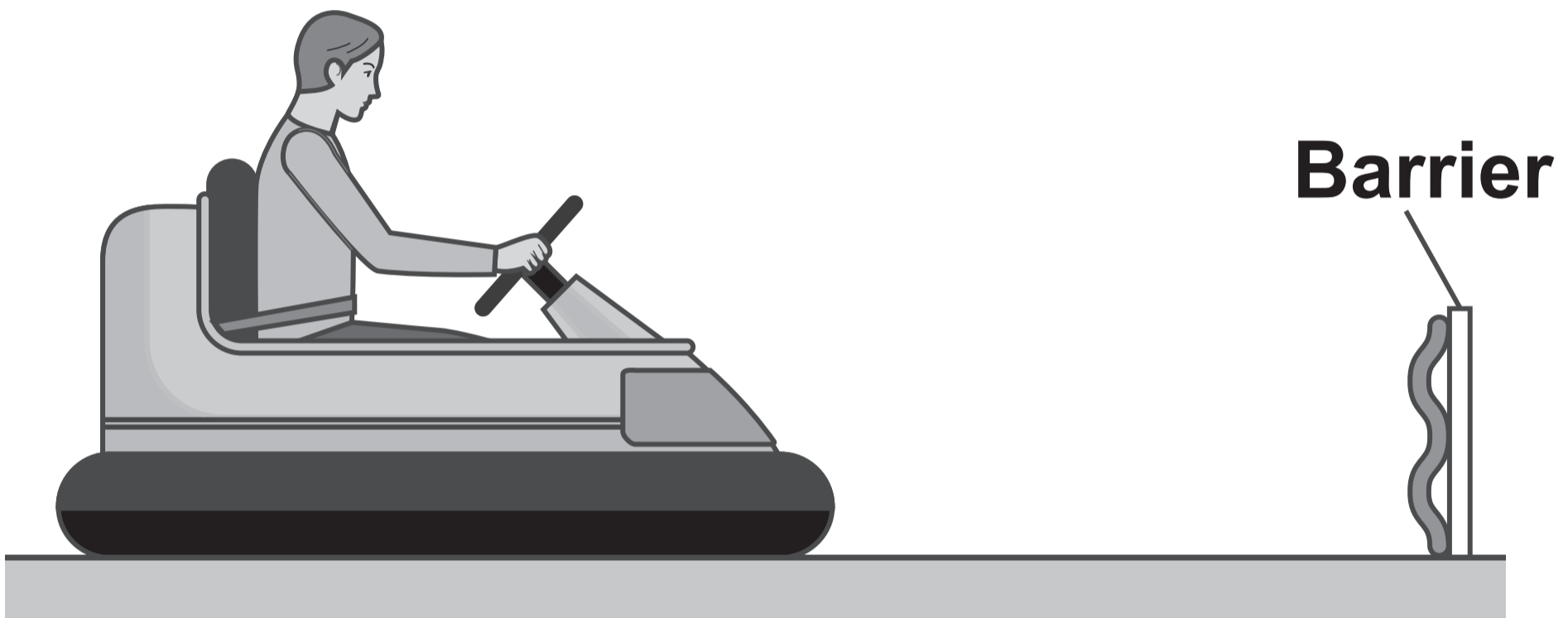

0 5 . 1

FIGURE 8, on the opposite page, shows how the speed of the bumper car changed during a time of 20 seconds.

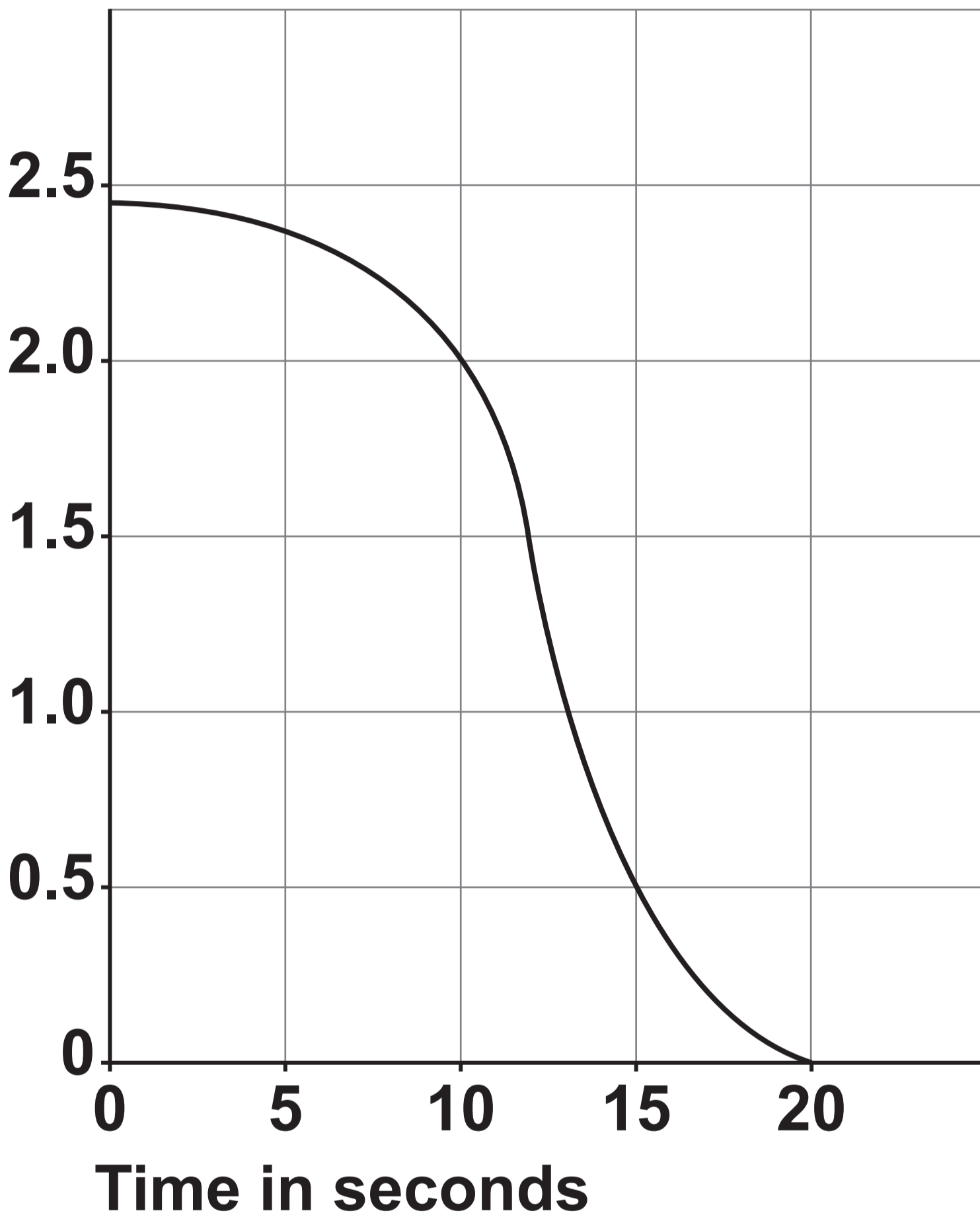

FIGURE 8**Speed in m/s****[Turn over]**

**Estimate the distance travelled by the bumper car during the 20 seconds.
[3 marks]**

Distance = _____ m

0	5	.	2
---	---	---	---

The bumper car motor has an efficiency of 80%.

The useful power output of the motor is 220 W.

Calculate the total power input to the motor.

Use the Physics Equations Sheet.
[4 marks]

[Turn over]



Total power input = _____ W



0 5 . 4

When the bumper car collided with the barrier, the bumper car came to a stop in a time of 600 ms.

The deceleration of the student was 2.0 m/s^2 .

Calculate the initial velocity of the student.

**Use the Physics Equations Sheet.
[4 marks]**



Initial velocity = _____ m/s

14

[Turn over]



0	6
---	---

This question is about the extraction of metals.

0	6	.	1
---	---	---	---

Name the process that uses bacteria to extract metals. [1 mark]



0	6	.	2
---	---	---	---

Iron can be extracted from iron oxide using carbon.

The word equation for the reaction is:

iron oxide + carbon \longrightarrow

iron + carbon dioxide

Explain why this reaction is both oxidation AND reduction. [2 marks]

[Turn over]



0	6	.	3
---	---	---	---

Give ONE reason why some metals cannot be extracted from their oxides using carbon. [1 mark]

0	6	.	4
---	---	---	---

Aluminium is manufactured by the electrolysis of a molten mixture of aluminium oxide and cryolite.

Explain why cryolite is used. [2 marks]

[Turn over]



0	6	.	5
---	---	---	---

Aluminium is produced at the negative electrode.

Complete the half equation for the reaction.

You should balance the equation.
[2 marks]



8



BLANK PAGE

[Turn over]



0	7
---	---

This question is about chemical quantities.

0	7	.	1
---	---	---	---

0.40 dm³ of a solution contains 48.4 g of solute.

Calculate the concentration of the solution.

Give the unit. [3 marks]



Concentration of solution =

Unit

[Turn over]



0	7	.	2
---	---	---	---

Calculate the number of carbon dioxide molecules in 3.00 moles of carbon dioxide.

The Avogadro constant = 6.02×10^{23} per mole.

**Give your answer to 3 significant figures.
[3 marks]**



Number of molecules (3 significant figures) = _____

[Turn over]



0	7	.	3
---	---	---	---

Metal M forms a metal oxide with the formula M_2O_3

The relative formula mass of the metal oxide is 152.

Determine the identity of metal M.

Relative atomic mass (A_r): O = 16
[4 marks]



Metal M = _____

10

[Turn over]



0	8
---	---

This question is about the periodic table.

0	8	.	1
---	---	---	---

The halogens are in Group 7 of the periodic table.

Explain the trend in reactivity going down Group 7. [4 marks]



[Turn over]



0	8	.	2
---	---	---	---

Explain how the electronic structure of calcium relates to calcium reacting as a metal. [2 marks]



0	8	.	3
---	---	---	---

Rubidium has an atomic number of 37.

Complete the equation for the reaction of rubidium with water.

You should balance the equation.

Use the periodic table. [3 marks]



9

[Turn over]



0	9
---	---

A normal bicycle can be converted into an electric bicycle.

FIGURE 9 shows a converted bicycle.

FIGURE 9



FIGURE 10 shows the circuit diagram for the bicycle.

FIGURE 10

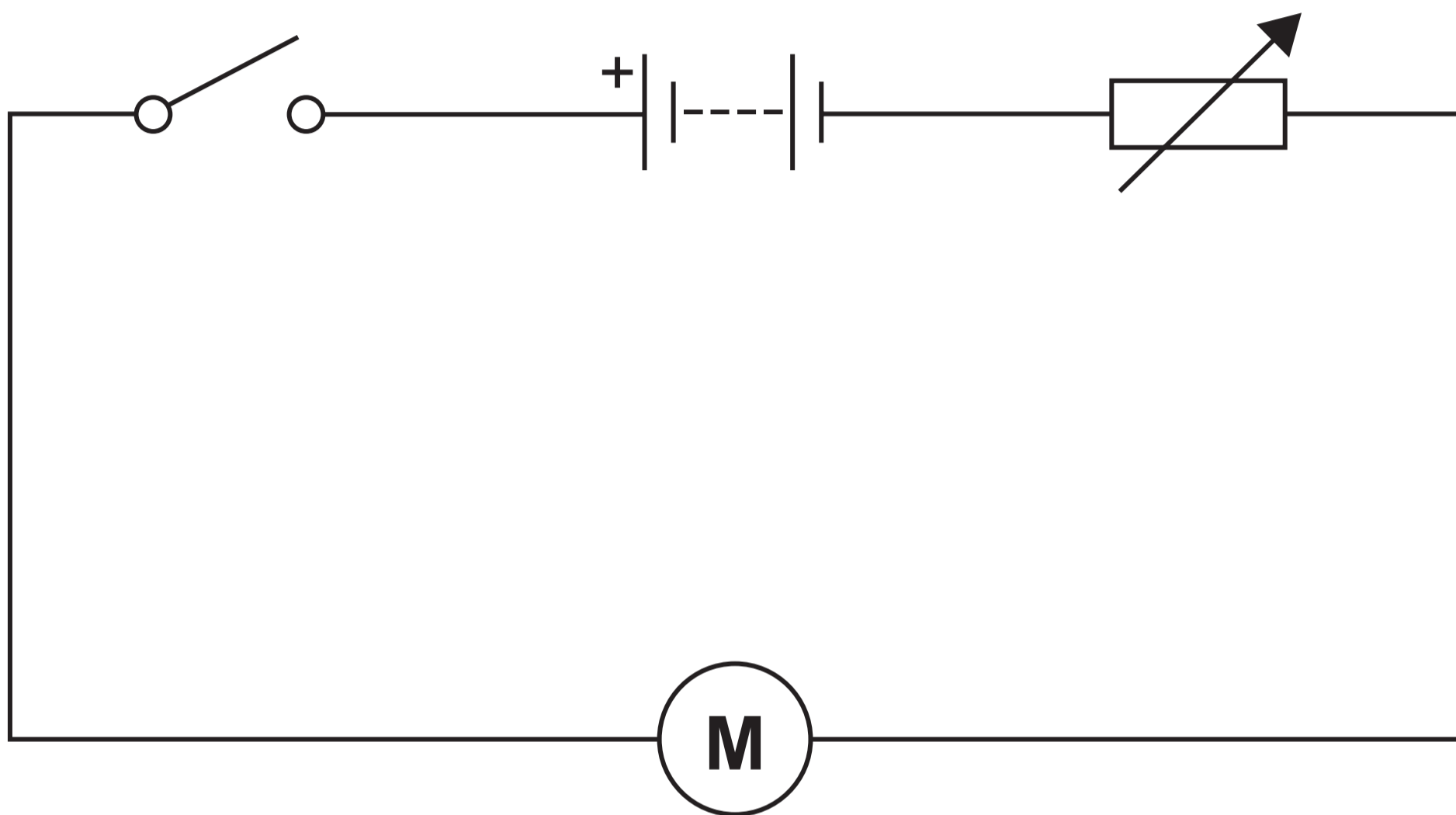

The circuit symbol for a motor is: (M)

[Turn over]



BLANK PAGE



The battery can be recharged using the mains electricity supply.

09.2

The mains supply is alternating current.

FIGURE 11 shows a simplified version of the circuit that is used to recharge the battery.

FIGURE 11

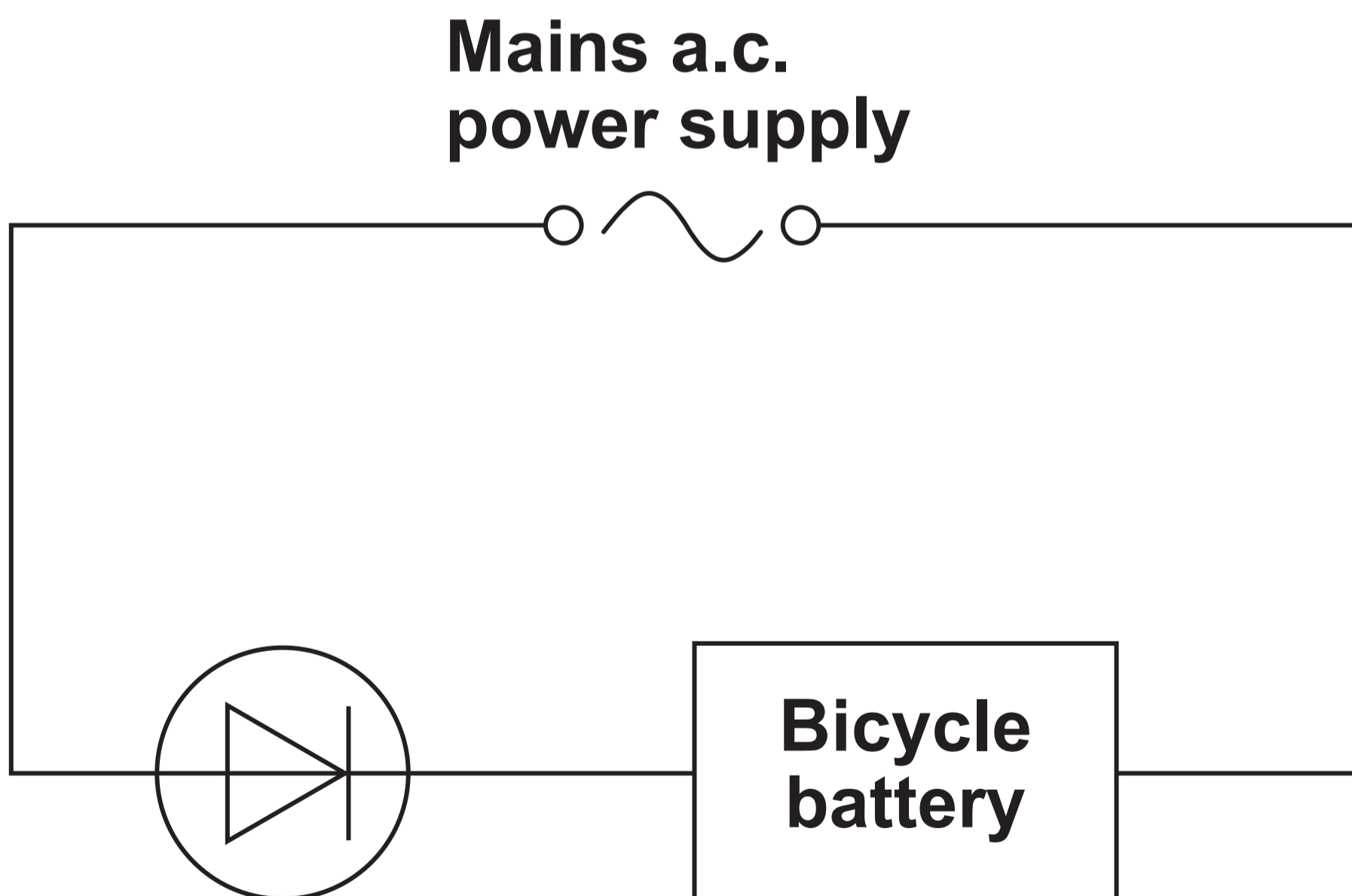

0	9	.	3
---	---	---	---

The mains supply fully recharged the battery in 2 hours.

The mean charging current was 5.0 A.

The resistance of the battery was 0.18 Ω .

Calculate the energy dissipated due to the resistance of the battery in 2 hours.

**Use the Physics Equations Sheet.
[5 marks]**



BLANK PAGE



BLANK PAGE

For Examiner's Use	
Question	Mark
1	
2	
3	
4	
5	
6	
7	
8	
9	
TOTAL	

Copyright information

For confidentiality purposes, all acknowledgements of third-party copyright material are published in a separate booklet. This booklet is published after each live examination series and is available for free download from www.aqa.org.uk.

Permission to reproduce all copyright material has been applied for. In some cases, efforts to contact copyright-holders may have been unsuccessful and AQA will be happy to rectify any omissions of acknowledgements. If you have any queries please contact the Copyright Team.

Copyright © 2022 AQA and its licensors. All rights reserved.

G/LM/Jun22/8465/3H/E1