



Surname _____

Forename(s) _____

Centre Number _____

Candidate Number _____

Candidate Signature _____

I declare this is my own work.

A-level

PHYSICS

Paper 3

Section B Electronics

7408/3BE

Thursday 15 June 2023

Morning

At the top of the page, write your surname and other names, your centre number, your candidate number and add your signature.

[Turn over]



JUN2374083BE01

Time allowed: The total time for both sections of this paper is 2 hours. You are advised to spend approximately 50 minutes on this section.

MATERIALS

For this paper you must have:

- a pencil and a ruler
- a scientific calculator
- a Data and Formulae Booklet
- a protractor.

INSTRUCTIONS

- Use black ink or black ball-point pen.
- Answer ALL questions.
- You must answer the questions in the spaces provided. Do not write on blank pages.
- If you need extra space for your answer(s), use the lined pages at the end of this book. Write the question number against your answer(s).
- Do all rough work in this book. Cross through any work you do not want to be marked.
- Show all your working.



INFORMATION

- **The marks for questions are shown in brackets.**
- **The maximum mark for this paper is 35.**
- **You are expected to use a scientific calculator where appropriate.**
- **A Data and Formulae Booklet is provided as a loose insert.**

DO NOT TURN OVER UNTIL TOLD TO DO SO



SECTION B

Answer ALL questions in this section.

0	1
---	---

FIGURE 1 shows the input and output pins for a 4-bit binary counter. The output pin for the least significant bit is A.

FIGURE 1

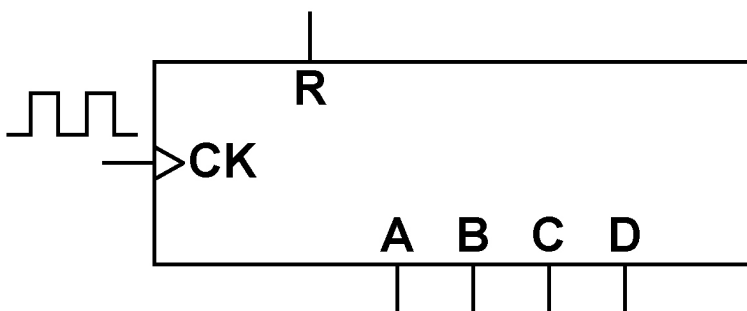

0	1	.	1
---	---	---	---

Complete FIGURE 1, on the opposite page, by adding a single logic gate to the binary counter so that the circuit functions as a modulo-6 counter. [2 marks]

[Turn over]

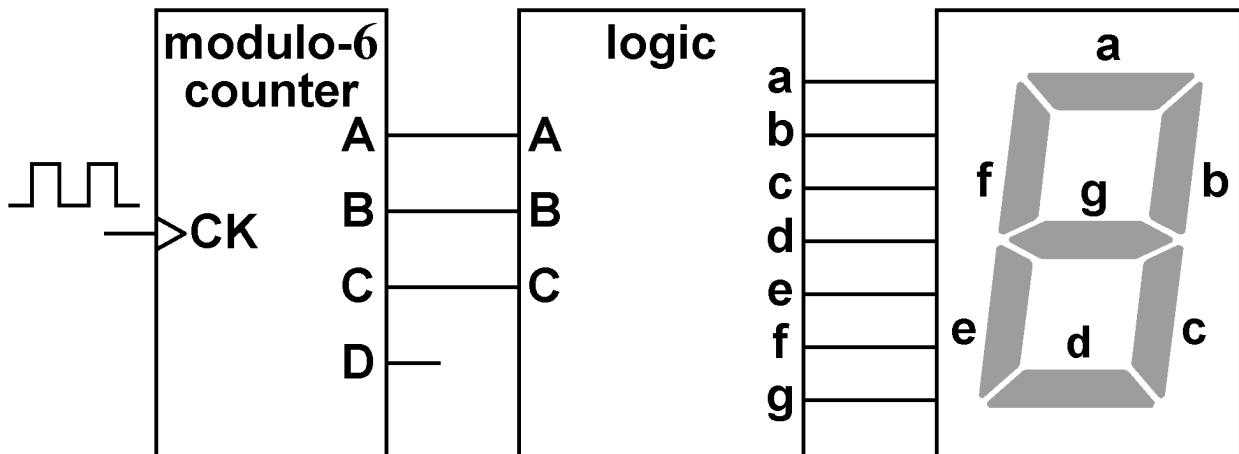

FIGURE 2 shows three outputs of the modulo-6 counter connected to a logic sub-system that controls a 7-segment display.

The decimal point on the display is not shown.

The whole system shown in **FIGURE 2** is to be used as an electronic dice.

FIGURE 2



Segments in the 7-segment display are turned on or off by the logic sub-system to display the decimal numbers 1 to 6 in sequence.

A segment in the display turns on when the logic output with the same letter as the segment is at logic 1.



BLANK PAGE

[Turn over]





TABLE 1 shows how the values of CBA control the logic level applied to each of the segments a to g during the counting cycle.

TABLE 1

LOGIC INPUTS			LOGIC OUTPUTS						
C	B	A	a	b	c	d	e	f	g
0	0	0	0	1	1	0	0	0	0
0	0	1	1	1	0	1	1	0	1
0	1	0	1	1	1	1	0	0	1
0	1	1	0	1	1	0	0	1	1
1	0	0	1	0	1	1	0	1	1
1	0	1	1	0	1	1	1	1	1



0 9

0 1 . 2

One of the logic outputs a to g is controlled by a single NOT gate. This gate uses one of the inputs A, B or C.

State the input that is used and the segment that this NOT gate controls. [1 mark]

input = _____

segment = _____

[Turn over]



0 1 . 3

X represents one of the logic outputs. The Boolean expression for this output is:

$$X = (A \cdot B) + C$$

State which of the logic outputs a to g is being controlled by this function.
[1 mark]

Logic output = _____



BLANK PAGE

[Turn over]



1 2

0 1 . 4

Y represents another of the logic outputs. The Boolean expression for this output is:

$$Y = (\overline{A} \cdot \overline{B}) + (\overline{B} \cdot \overline{C})$$

Complete FIGURE 3, on the opposite page, to show the combination of logic gates needed to represent the expression.

You should only use logic gates that represent the individual functions shown in the expression. [3 marks]



FIGURE 3

Ao

Bo

Co

oY

[Turn over]

02

FIGURE 4 shows a strain gauge that consists of a folded metal wire glued to a piece of insulating material.

FIGURE 4

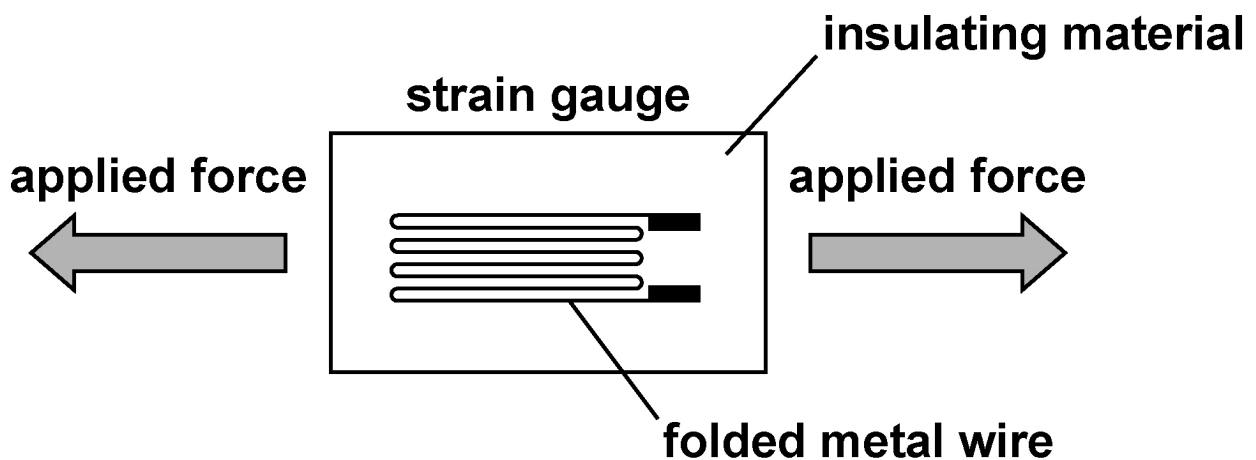

The resistance of the metal wire:

- **increases when the gauge is stretched by forces applied as shown**
- **changes when there is a change in temperature.**



BLANK PAGE

[Turn over]



0	2	.	1
---	---	---	---

FIGURE 5, on the opposite page, shows a circuit that contains two identical strain gauges A and B.

The resistance of each strain gauge is $120.00\ \Omega$ when the strain is zero.

R_1 is a $560\ \Omega$ fixed resistor.

R_2 is a $100\ \Omega$ variable resistor.

R_3 is a $510\ \Omega$ fixed resistor.

Assume that the voltmeter is ideal.



FIGURE 5

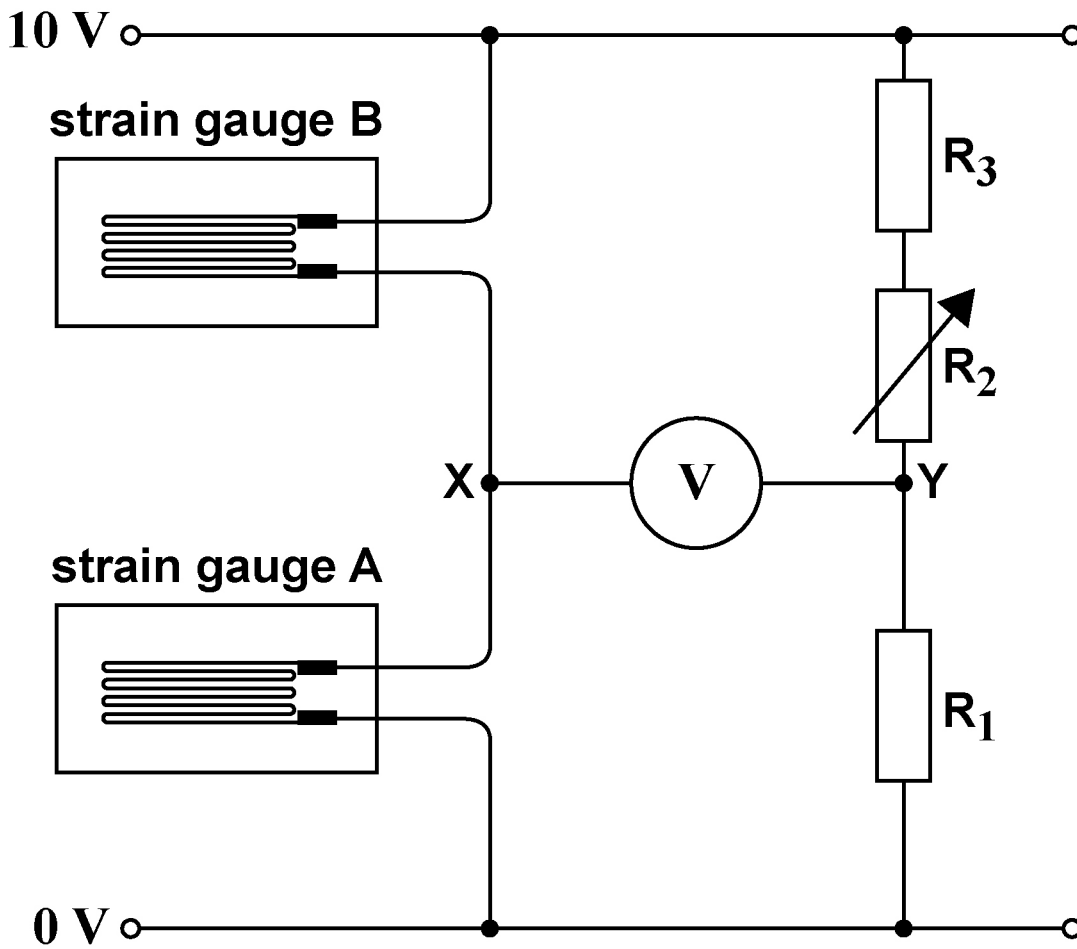

[Turn over]



The circuit is used to measure changes in strain in a metal beam.

A is glued firmly to the metal beam.

B is placed on the beam near A but is not glued to the beam.

Initially, with the gauges under zero strain, R_2 is adjusted to produce 0 V on the voltmeter.

When the beam bends, A stretches and B remains unstretched.

The resistance of A increases to 120.06Ω .

Calculate, in mV, the new reading on the voltmeter.
[3 marks]

reading on the voltmeter = _____ mV



0	2	.	3
---	---	---	---

The voltages at X and Y in FIGURE 5, on page 17, are now used as inputs to an operational amplifier.

The operational amplifier is configured as a difference amplifier with a gain of +5

Complete FIGURE 6, on the opposite page, to show the difference amplifier circuit.

Any resistors used must be labelled with their values. These values must be in the range 10 k Ω –10 M Ω .

Do not show the supply rails. [3 marks]



FIGURE 6

Y.

X.

0 V. —————

[Turn over]

8





0 3 . 1

FIGURE 7 shows a block diagram for part of a communication system that transmits control information from Earth to a satellite.

FIGURE 7

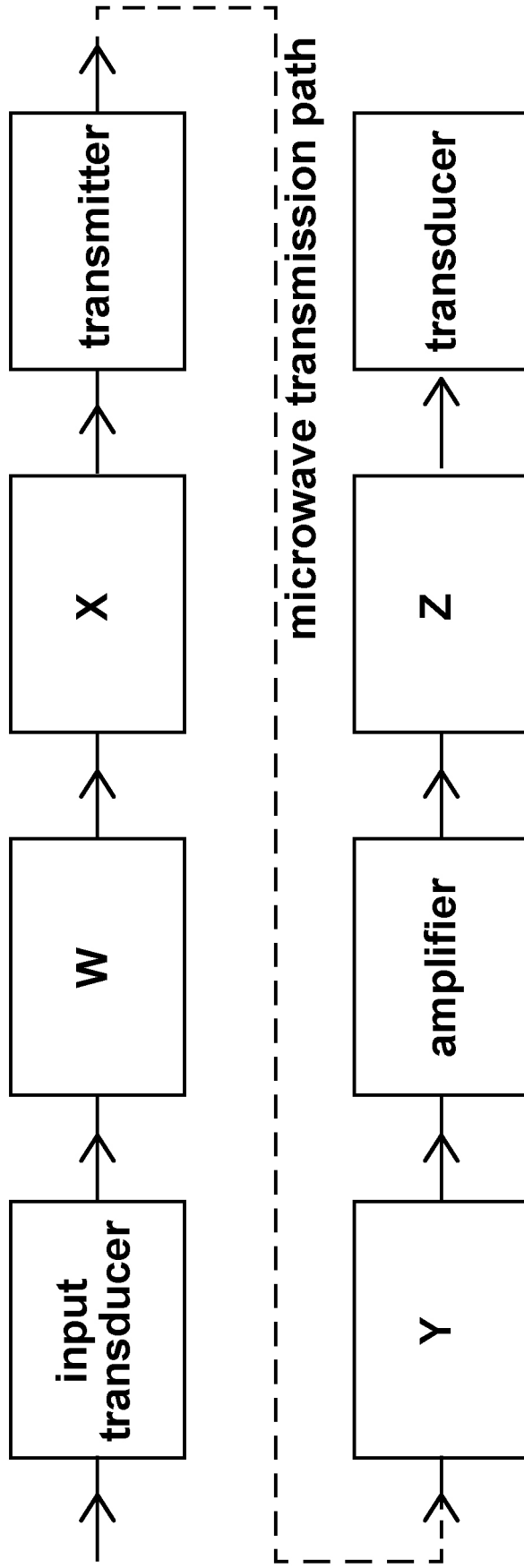



Which row gives the functions of the boxes W, X, Y and Z in FIGURE 7? [1 mark]

Tick (✓) ONE box.

	W	X	Y	Z
<input type="checkbox"/>	amplifier	modulator	demodulator	receiver
<input type="checkbox"/>	modulator	amplifier	receiver	demodulator
<input type="checkbox"/>	demodulator	amplifier	modulator	receiver
<input type="checkbox"/>	amplifier	demodulator	receiver	modulator

[Turn over]

0	3	.	2
---	---	---	---

Syncom 3 was the first geostationary communication satellite.

The satellite was used to broadcast television signals of the 1964 Olympic Games from Tokyo in Japan to Los Angeles in the USA.

**State what is required so that de-sensing does not occur in a radio receiver such as that on Syncom 3.
[1 mark]**



Commentators in Los Angeles interviewed athletes in Tokyo using Syncom 3.

The commentators found that there was a significant time delay between the end of each question and the arrival of its reply.

This time delay was made up of:

- **the total time that the signals spent travelling**
- **the total processing time.**

[Turn over]



0	3	.	3
---	---	---	---

The distance of the geostationary satellite from both Tokyo and Los Angeles was 40 000 km.

The time delay was 900 ms.

Calculate, in ms, the total processing time. [2 marks]

total processing time = _____ ms



0	3	.	5
---	---	---	---

For the 2020 Olympics, digital TV signals between Tokyo and Los Angeles used a fibre-optic cable. The cable lies on the seabed.

Explain why a fibre-optic cable rather than a satellite link is now preferred for intercontinental communication. [2 marks]

—
8



BLANK PAGE

[Turn over]



0	4	.	1
---	---	---	---

A particular operational amplifier has the following properties:

- open-loop gain = 1×10^5
- break frequency (cutoff frequency) = 10 Hz
- gain \times bandwidth = 1 MHz.

Draw, on FIGURE 8, on the opposite page, the variation of gain with frequency for this operational amplifier in open-loop mode. [2 marks]



FIGURE 8

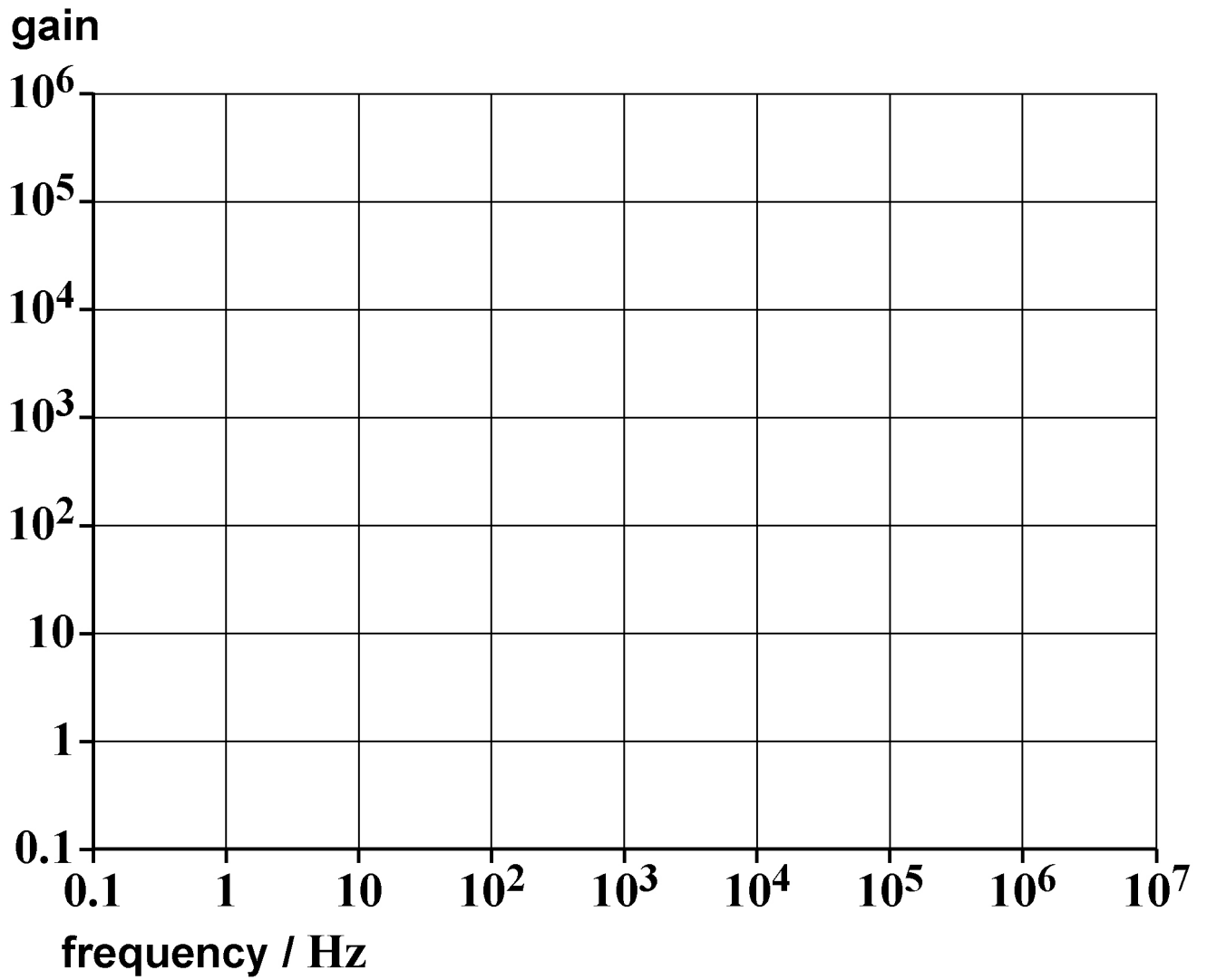

[Turn over]



04.2

FIGURE 9 shows the operational amplifier being used in an inverting amplifier circuit.

FIGURE 9

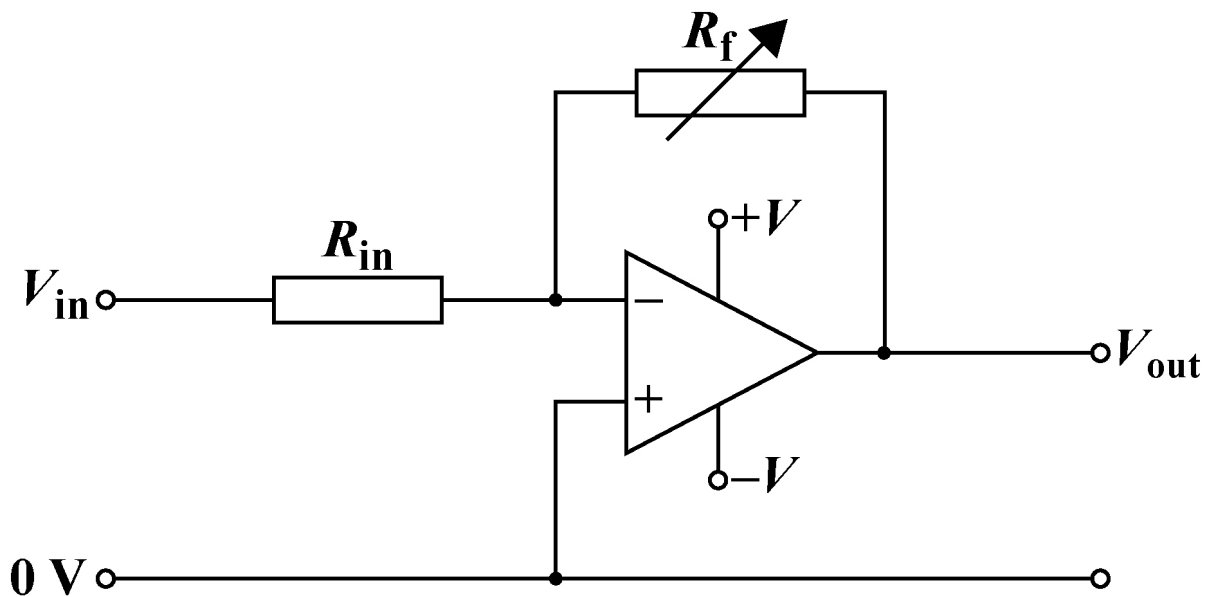

Annotate FIGURE 9 with:

- an X to indicate a point that acts as a virtual earth
- arrows to show the direction of current I in both resistors when the input voltage V_{in} is negative.

[2 marks]





0 5

FIGURE 10 shows a circuit that has an input signal which is a noisy square wave. The circuit is used to remove the noise and switch a motor M on and off.

FIGURE 10

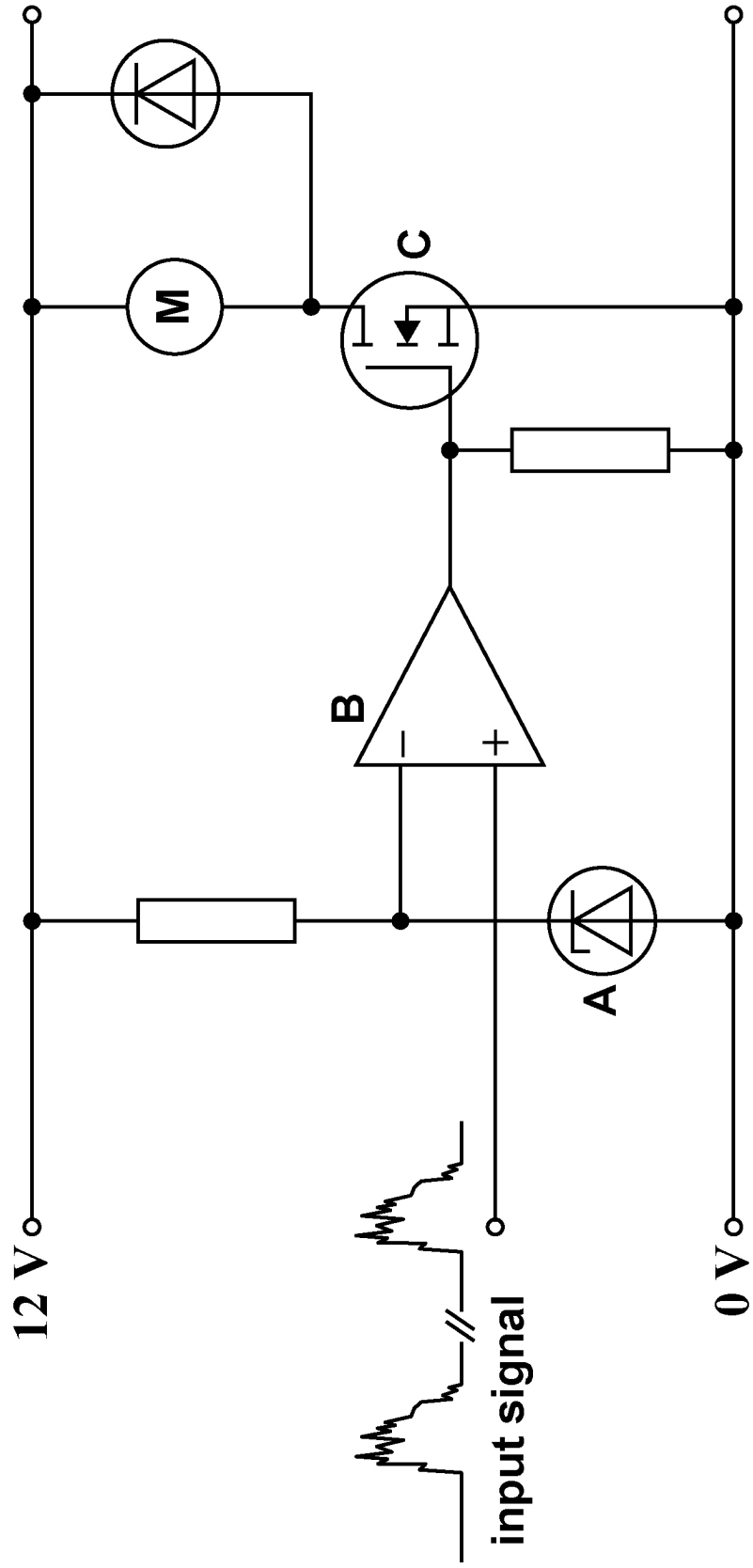



Explain the functions of components A, B and C.

For each of these components you should:

- **explain its role in the circuit**
- **identify the characteristic properties that make the component suitable for this role.**

[6 marks]

[Turn over]

--	--	--	--	--	--	--	--	--	--	--



[Turn over]



--	--	--	--	--	--	--	--	--	--





6

END OF QUESTIONS

BLANK PAGE

For Examiner's Use	
Question	Mark
1	
2	
3	
4	
5	
TOTAL	

Copyright information

For confidentiality purposes, all acknowledgements of third-party copyright material are published in a separate booklet. This booklet is published after each live examination series and is available for free download from www.aqa.org.uk.

Permission to reproduce all copyright material has been applied for. In some cases, efforts to contact copyright-holders may have been unsuccessful and AQA will be happy to rectify any omissions of acknowledgements. If you have any queries please contact the Copyright Team.

Copyright © 2023 AQA and its licensors. All rights reserved.

WP/M/MW/Jun23/7408/3BE/E3