



Surname _____

Forename(s) _____

Centre Number _____

Candidate Number _____

Candidate Signature _____

I declare this is my own work.

GCSE

CHEMISTRY

H

Higher Tier Paper 2

8462/2H

Tuesday 11 June 2024

Morning

Time allowed: 1 hour 45 minutes

At the top of the page, write your surname and forename(s), your centre number, your candidate number and add your signature.

[Turn over]



JUN2484622H01

MATERIALS

For this paper you must have:

- a ruler
- a scientific calculator
- the periodic table (enclosed).

INSTRUCTIONS

- Use black ink or black ball-point pen.
- Pencil should only be used for drawing.
- Answer ALL questions in the spaces provided. Do not write on blank pages.
- If you need extra space for your answer(s), use the lined pages at the end of this book. Write the question number against your answer(s).
- Do all rough work in this book. Cross through any work you do not want to be marked.



INFORMATION

- **The maximum mark for this paper is 100.**
- **The marks for questions are shown in brackets.**
- **You are expected to use a calculator where appropriate.**
- **In all calculations, show clearly how you work out your answer.**
- **You are reminded of the need for good English and clear presentation in your answers.**

DO NOT TURN OVER UNTIL TOLD TO DO SO



0	1
---	---

A student investigated an aqueous solution of a salt.

The student identified that the salt solution contained only sodium ions and chloride ions.

0	1	.	1
---	---	---	---

Describe a test to identify sodium ions.

Give the result of the test. [2 marks]

Test for sodium ions _____

Result _____



0 1 . 2

Describe a test to identify chloride ions.

Give the result of the test. [2 marks]

Test for chloride ions _____

Result _____

[Turn over]



The student determined the concentration of sodium chloride in the salt solution.

This is the method used.

1. Weigh an empty evaporating dish.
2. Add 25.0 cm^3 of the salt solution into the evaporating dish.
3. Heat the evaporating dish and contents.
4. Weigh the evaporating dish and contents.
5. Repeat steps 3 to 4 until there is no further change in mass.
6. Repeat steps 1 to 5 three more times.

0 1 . 3

Why did the student heat the evaporating dish and contents until the mass did not change? [1 mark]



01.4

How did the student calculate the mass of solid sodium chloride remaining after steps 1 to 5?

[1 mark]

Tick (✓) ONE box.

Mass of 25 cm³ of salt solution + mass of empty evaporating dish

Mass of 25 cm³ of salt solution – mass of empty evaporating dish

Mass of evaporating dish and dry contents + mass of empty evaporating dish

Mass of evaporating dish and dry contents – mass of empty evaporating dish

[Turn over]



0 1 . 5

The student calculated the concentration of sodium chloride in the salt solution.

TABLE 1 shows the results.

TABLE 1

Concentration of sodium chloride in g/dm ³			
TRIAL 1	TRIAL 2	TRIAL 3	TRIAL 4
35.2	34.6	36.4	33.8

The percentage by mass of sodium ions in sodium chloride is 39.3%.

Calculate the mean concentration of sodium ions in the salt solution. [4 marks]



Mean concentration = _____ g/dm³

[Turn over]

10



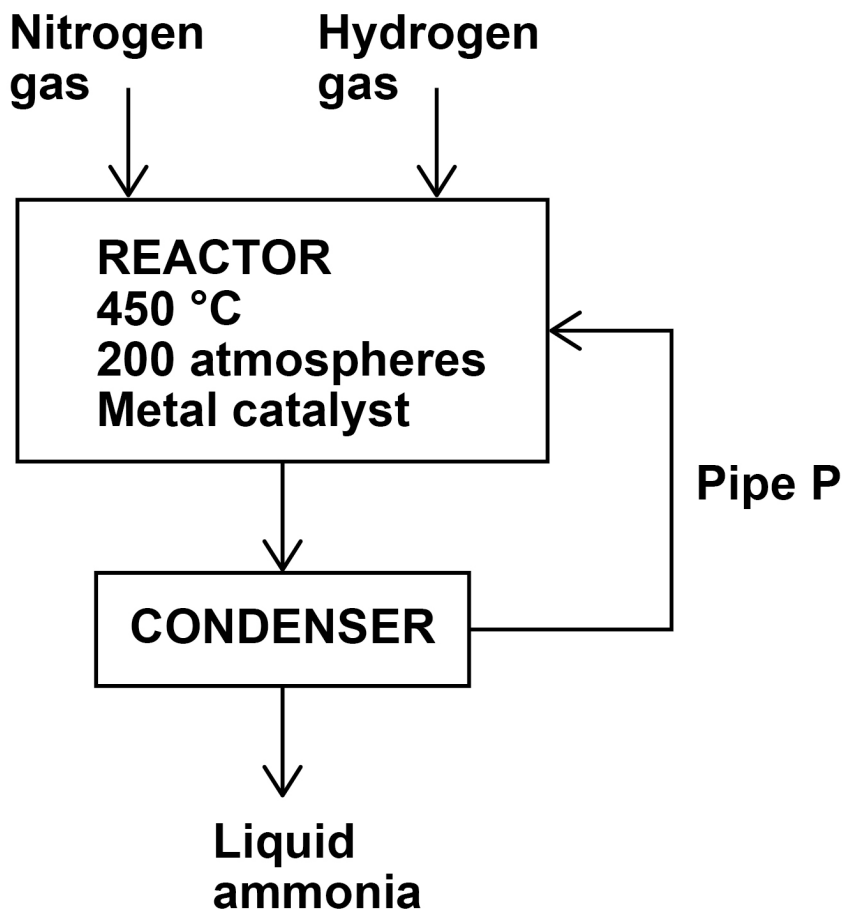
0 2

This question is about ammonia and nitric acid.

In the Haber process ammonia is produced from nitrogen and hydrogen.

FIGURE 1 represents the Haber process.

FIGURE 1



0 2 . 1

Pipe P links the condenser to the reactor.

Why is the condenser linked to the reactor?

Use FIGURE 1. [1 mark]

0 2 . 2

Which metal is used as a catalyst in this reaction?
[1 mark]

[Turn over]



Nitric acid is produced by reacting ammonia with oxygen.

The word equation for the production of nitric acid is:

ammonia + oxygen \longrightarrow water + nitric acid

Platinum is a catalyst in this reaction.

0 2 . 3

Describe the test for oxygen gas.

Give the result if oxygen gas is present. [2 marks]

Test _____

Result _____



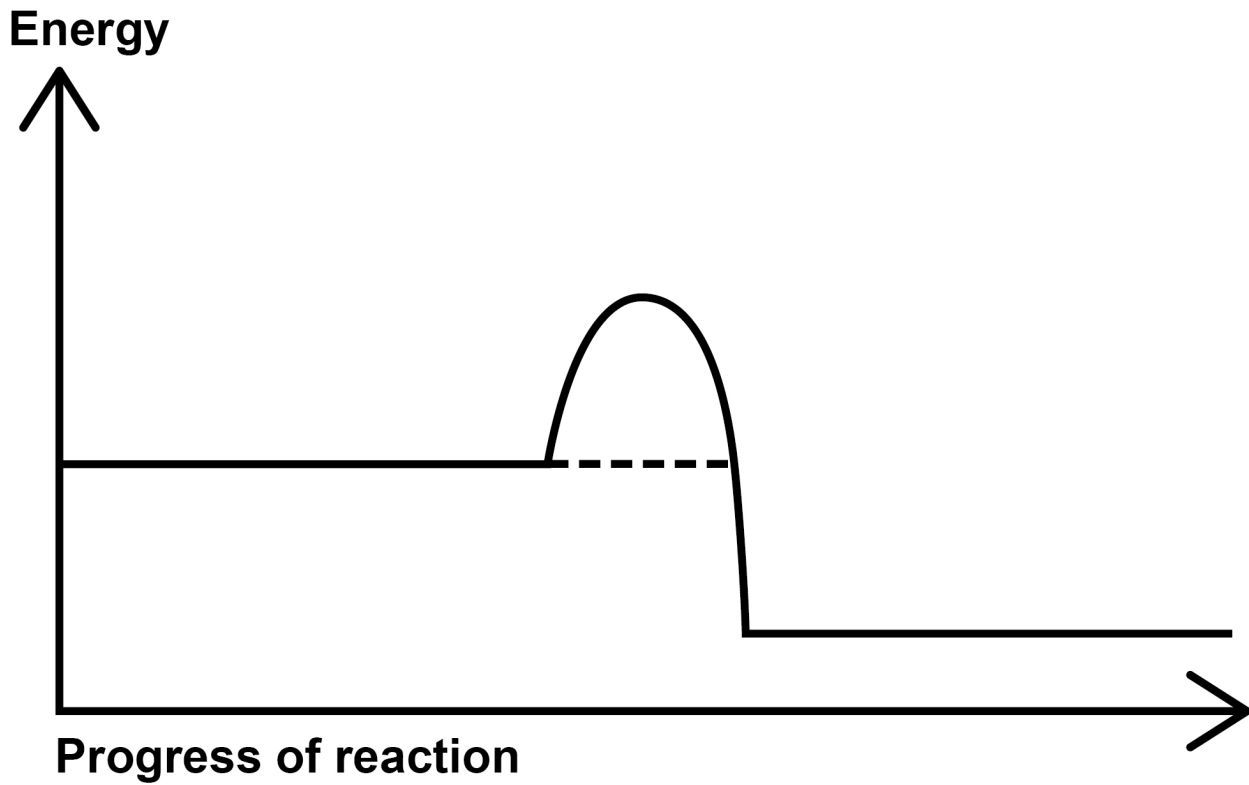
BLANK PAGE

[Turn over]



FIGURE 2 represents the reaction profile of the catalysed reaction between ammonia and oxygen.

FIGURE 2



0 2 . 4

Complete the reaction profile for the catalysed reaction in FIGURE 2.

You should:

- **label the activation energy**
- **label the reactants and products, using the names of the reactants and products.**

[2 marks]

0 2 . 5

How would FIGURE 2 be different if NO catalyst was used? [1 mark]

Tick (✓) ONE box.

The final energy level would be higher.

The final energy level would be lower.

The line would reach a higher peak.

The line would reach a lower peak.

[Turn over]



0	2	.	6
---	---	---	---

Ammonia and nitric acid react to produce the salt, ammonium nitrate.

Ammonium ions and nitrate ions both contain nitrogen.

Suggest ONE use of ammonium nitrate. [1 mark]

8



0	3
---	---

This question is about water.

0	3	.	1
---	---	---	---

Hydrogen gas reacts with oxygen gas to produce water.

Water is decomposed into hydrogen gas and oxygen gas using electricity.

Which TWO words describe the reaction between hydrogen gas and oxygen gas? [2 marks]

Tick (✓) TWO boxes.

Alloying

Combustion

Corrosion

Endothermic

Reversible

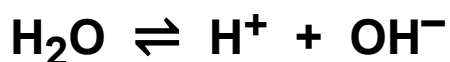
[Turn over]



03.2

Water molecules break down into hydrogen ions and hydroxide ions.

The equation for the reaction is:



Which sentence describes this reaction at equilibrium? [1 mark]

Tick (✓) ONE box.

- Water molecules break down at a higher rate than they reform.
- Water molecules break down and reform at the same rate.
- Water molecules break down at a lower rate than they reform.



03.3

Water collected from rivers is used in the home for drinking and flushing toilets.

Water used in the home must be potable.

Potable water is safe to drink.

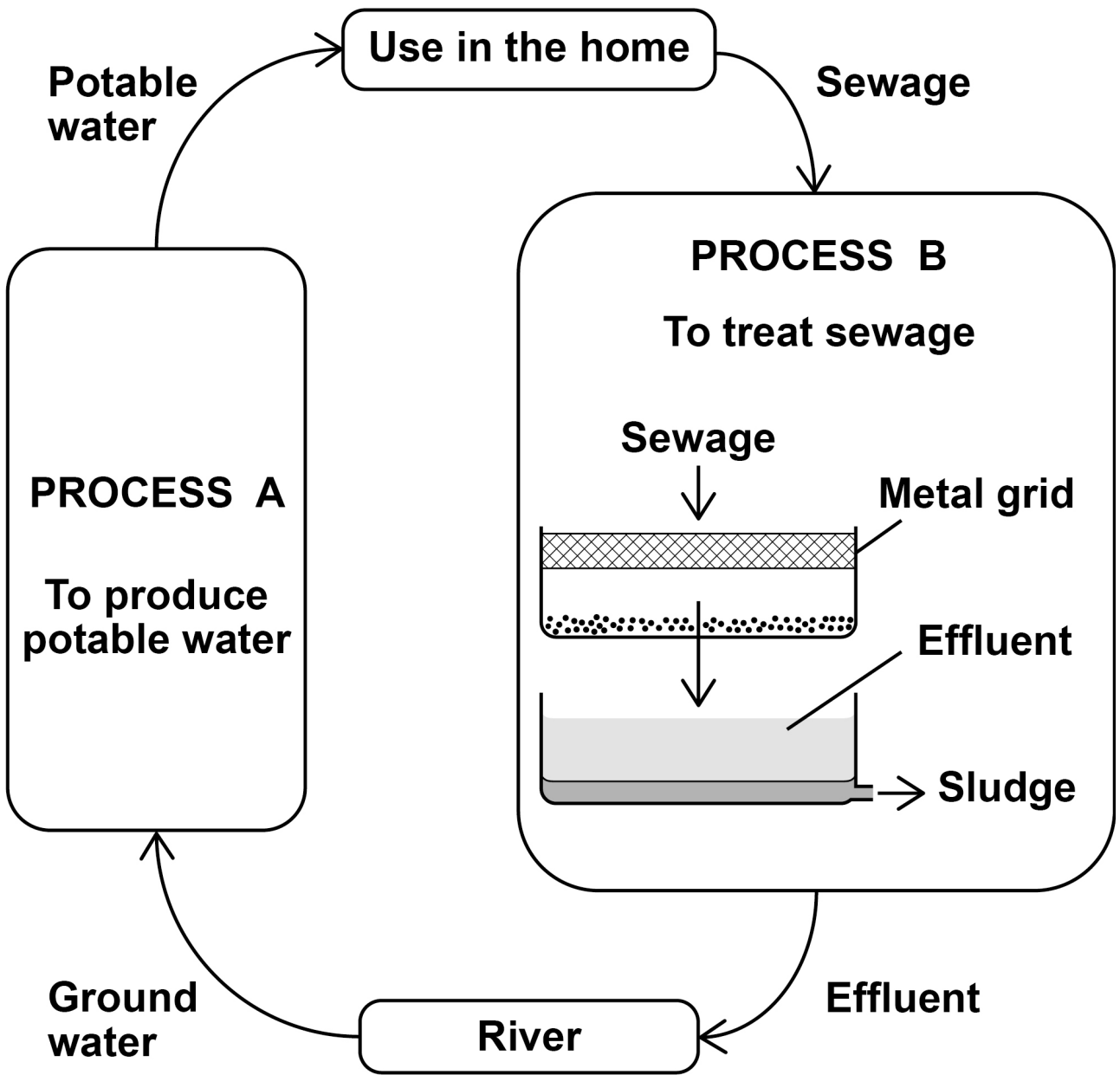
Waste water produced after use in the home is called sewage.

FIGURE 3, on page 20, shows how water is collected from rivers and returned to rivers after use.

[Turn over]



FIGURE 3



9



0	4
---	---

A student investigated an orange dye (A) using paper chromatography.

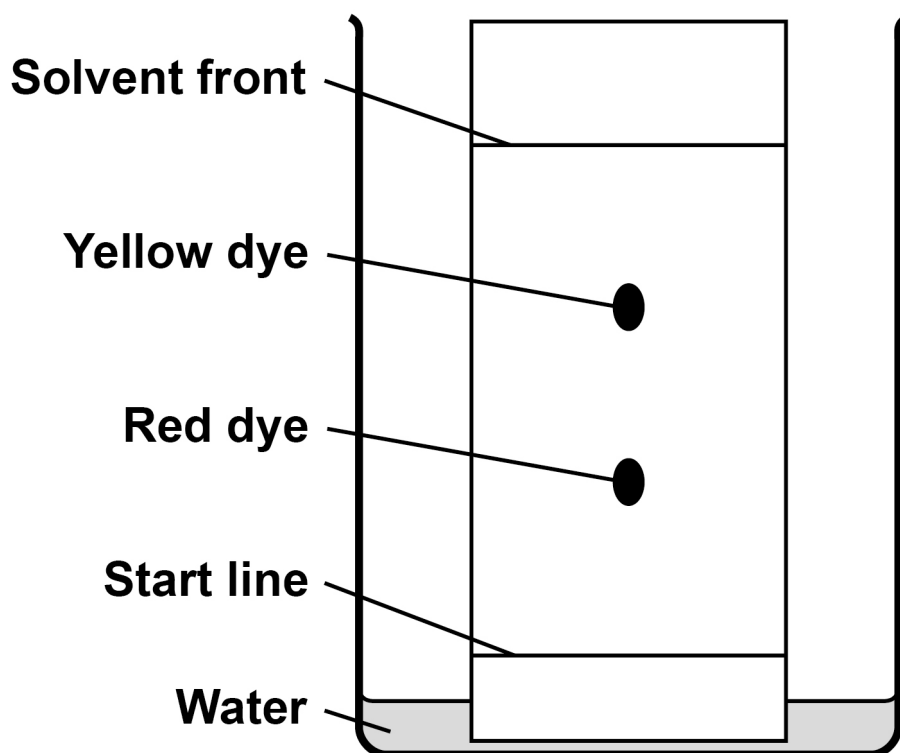
FIGURE 4, on page 24, shows the results of Experiment 1 and Experiment 2 using orange dye A.

[Turn over]

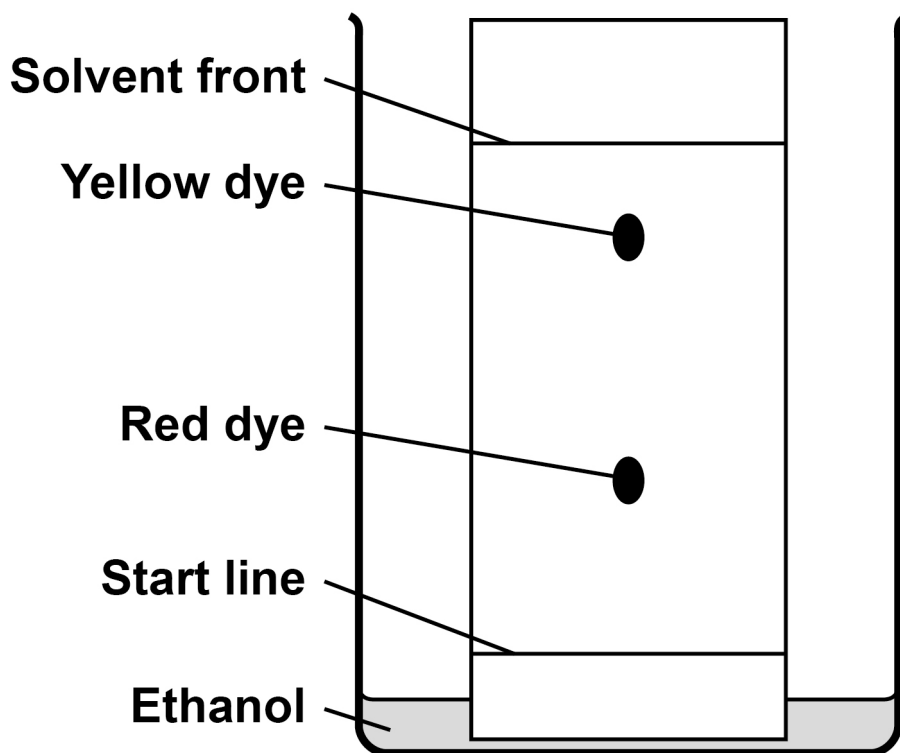


FIGURE 4

EXPERIMENT 1



EXPERIMENT 2



04.1

Explain why the yellow dye and red dye travel different distances in Experiment 1.

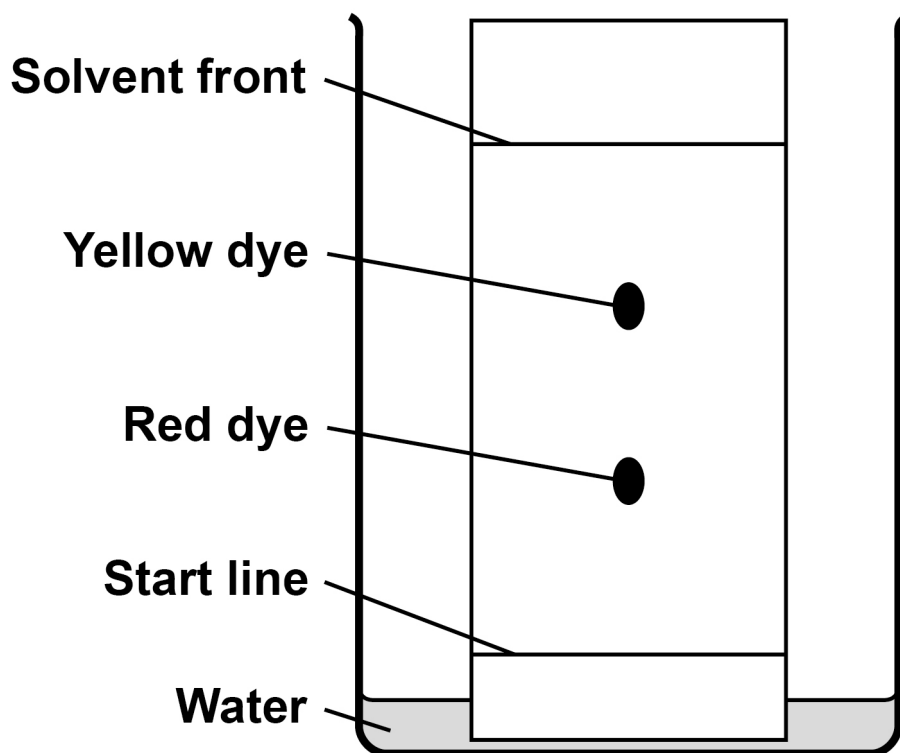
Refer to forces of attraction between the dyes and the chromatography paper in your answer. [2 marks]

[Turn over]

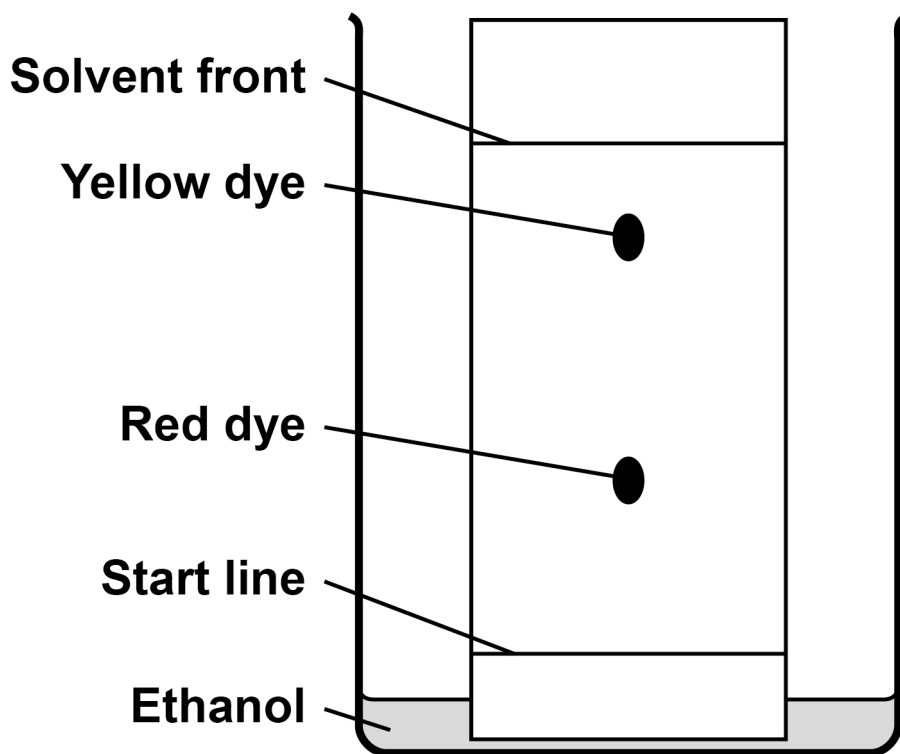


FIGURE 4

EXPERIMENT 1



EXPERIMENT 2



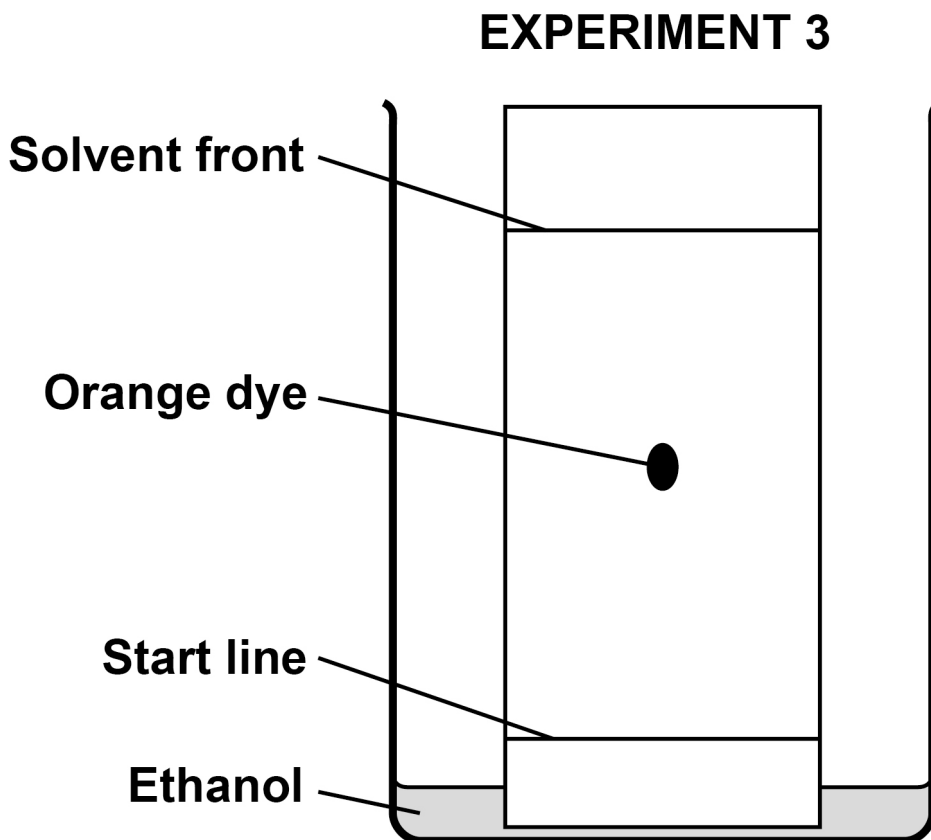
[Turn over]



The student investigated a different orange dye (B).

FIGURE 5 shows the results of Experiment 3 using orange dye B.

FIGURE 5



0	4	.	3
---	---	---	---

Compare the purity of the orange dyes A and B.

Give reasons for your answer.

**Use FIGURE 4 and FIGURE 5, on pages 27 and 28.
[2 marks]**

[Turn over]



0	4	.	4
---	---	---	---

The student calculated that the R_f value of the orange dye in the experiment shown in FIGURE 5, on page 28, was 0.48

Calculate the distance moved by the solvent front when the orange dye had moved 5.4 cm. [3 marks]

Distance moved by solvent front = _____ cm



0	4	.	5
---	---	---	---

Why is the R_f value of a dye NOT affected by how far the solvent front is allowed to travel? [1 mark]

[Turn over]



04.6

Another type of chromatography is called gas chromatography.

Gas chromatography is an instrumental method of chemical analysis.

Scientists tested the orange dyes using gas chromatography.

Suggest TWO advantages of using the instrumental method of gas chromatography rather than paper chromatography. [2 marks]

1

2

13

BLANK PAGE

[Turn over]



05

This question is about burning fuels in central heating boilers.

In the future, gas central heating boilers may burn hydrogen rather than natural gas.

TABLE 2 shows information about these fuels when 1 dm^3 of the fuel is burned in a central heating boiler.

TABLE 2

	FUEL	
	HYDROGEN	NATURAL GAS
Energy released in kJ	11.9	37.1
Mass of carbon dioxide produced in grams	0.00	1.83
Mass of water vapour produced in grams	0.75	1.50
Mass of oxides of nitrogen produced in grams	6.6×10^{-4}	4.9×10^{-4}



0	5	.	1
---	---	---	---

Explain how oxides of nitrogen are produced when burning fuels. [2 marks]

[Turn over]



05.2

Explain ONE positive impact on the environment of burning hydrogen rather than natural gas as a fuel.

Use TABLE 2, on page 34. [2 marks]



05.3

Explain ONE negative impact on the environment of burning hydrogen rather than natural gas as a fuel.

Use TABLE 2, on page 34. [2 marks]

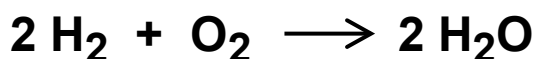
[Turn over]

0	5	.	4
---	---	---	---

Air is 20% oxygen.

Calculate the volume of air needed to provide enough oxygen to react with 3.50 dm³ of hydrogen gas.

The equation for the reaction is



[3 marks]

Volume of air = _____ dm³



BLANK PAGE



06

This question is about materials used to make bicycles.

FIGURE 6 shows a bicycle.

FIGURE 6



[Turn over]



TABLE 3 shows information about two materials used to make bicycle frames.

TABLE 3

	MATERIAL	
	ALUMINIUM ALLOY	BAMBOO
Raw material	aluminium ore	bamboo plant
Cost of frame in £	250	1500
Strength in arbitrary units	290	193
Mass in kilograms	1.6	2.4
Lifespan in years	6–10	10–15
One method of disposal at end of life	recycled to make new products	burned to produce heat energy



0	6	.	2
---	---	---	---

Explain why aluminium alloy bicycle frames do NOT need protection from corrosion. [2 marks]

[Turn over]



0	6	.	3
---	---	---	---

Bicycle chains are made from an alloy of iron.

Bicycle chains rust without protection.

Paint is NOT used to protect bicycle chains from rusting.

Suggest how bicycle chains can be protected from rusting. [1 mark]



0	6	.	4
---	---	---	---

Bicycle frames can also be made from a composite of carbon fibres embedded in a polymer resin.

What description is given in this composite to:

- the carbon fibre component
- the polymer resin component?

[2 marks]

Carbon fibre _____

Polymer resin _____

[Turn over]

11



0	7
---	---

This question is about sulfuric acid.

0	7	.	1
---	---	---	---

Sulfuric acid contains sulfate ions.

Describe the test for the presence of sulfate ions in sulfuric acid.

Give the result of the test. [2 marks]

Test _____

Result _____



One stage in the industrial production of sulfuric acid is the reaction of sulfur dioxide with oxygen to produce sulfur trioxide.

This reversible reaction reaches dynamic equilibrium.

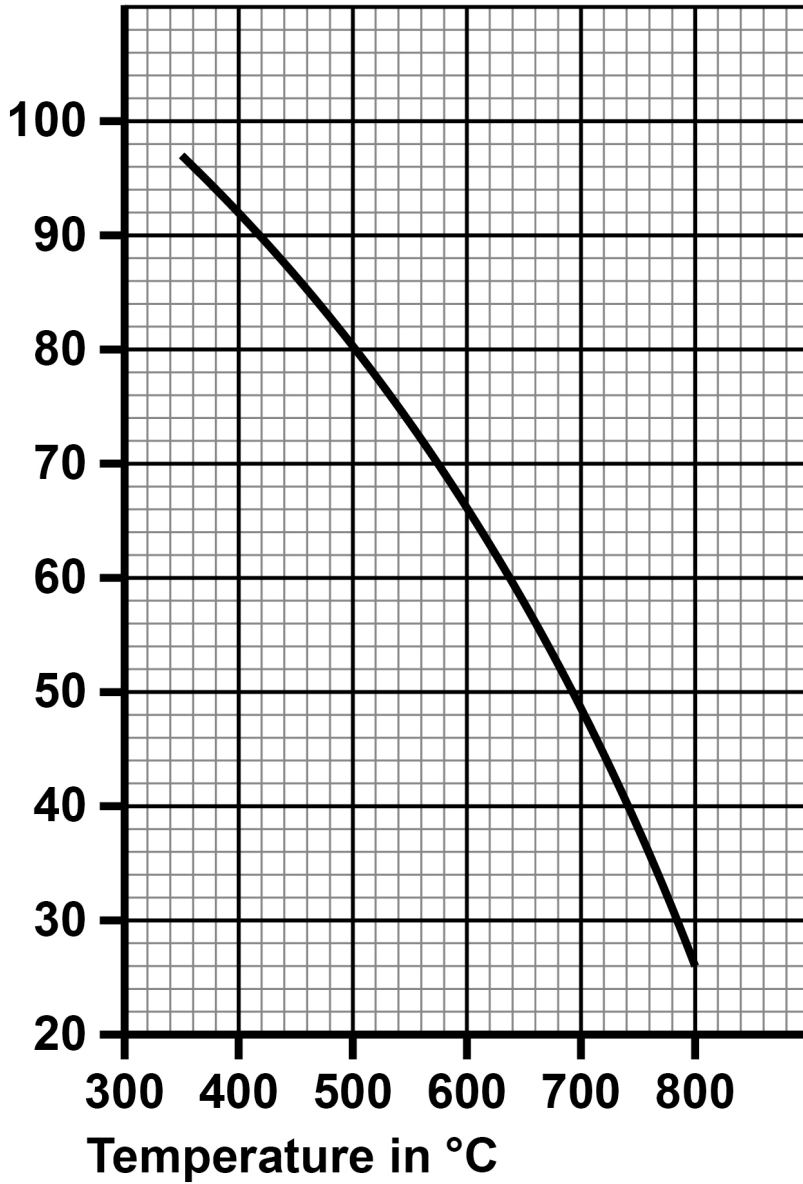
FIGURE 7, on page 50, shows the percentage yield of sulfur trioxide in this reaction at different temperatures.

[Turn over]



FIGURE 7

Percentage (%)
yield of sulfur
trioxide



07.2

Which statement about the forward reaction is correct?

Use FIGURE 7. [1 mark]

Tick (✓) ONE box.

The yield is greater at higher temperatures because the reaction is exothermic.

The yield is greater at higher temperatures because the reaction is endothermic.

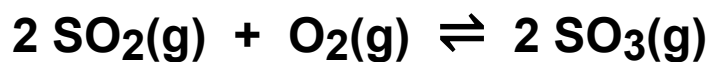
The yield is smaller at higher temperatures because the reaction is exothermic.

The yield is smaller at higher temperatures because the reaction is endothermic.

[Turn over]



The equation for the reaction is:



07.3

Explain why the percentage yield of sulfur trioxide in this reaction is greater if the pressure is higher.

[2 marks]



0	7	.	4
---	---	---	---

In industry, the reaction is done at 450 °C and atmospheric pressure.

Under these conditions the yield of sulfur trioxide is 86%.

Suggest TWO reasons why a higher pressure is NOT used. [2 marks]

1

2

[Turn over]



0	7	.	5
---	---	---	---

This reaction uses a catalyst to increase the rate of the reaction.

The catalyst is a metal oxide.

Which is the most likely metal in the metal oxide catalyst?

Use the periodic table. [1 mark]

Tick (✓) ONE box.

Aluminium (Al)

Barium (Ba)

Potassium (K)

Vanadium (V)

8



BLANK PAGE

[Turn over]



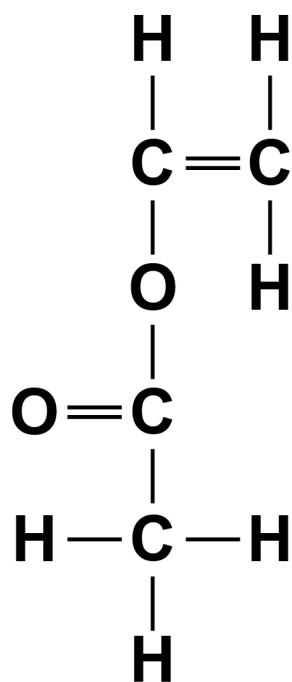
0	8
---	---

This question is about monomers and polymers.

Compound A has an alkene functional group and an ester functional group.

FIGURE 8 represents a molecule of compound A.

FIGURE 8



0	8	.	1
---	---	---	---

Draw a circle around the alkene functional group on FIGURE 8. [1 mark]



0	8	.	2
---	---	---	---

Describe what will be seen when compound A is shaken with bromine water. [2 marks]

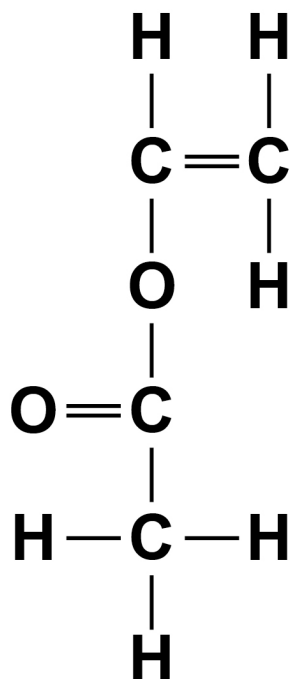
[Turn over]



0	8	.	3
---	---	---	---

FIGURE 9 is a repeat of FIGURE 8.

FIGURE 9



Draw a circle around the ester functional group on FIGURE 9. [1 mark]

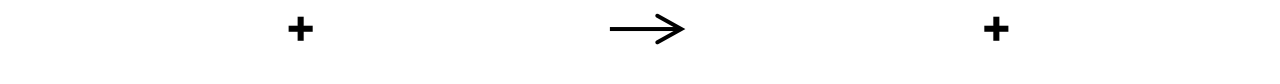


0	8	.	4
---	---	---	---

Compound A has the formula $C_4H_6O_2$

Compound A is flammable.

Write a balanced equation for the complete combustion of compound A. [3 marks]



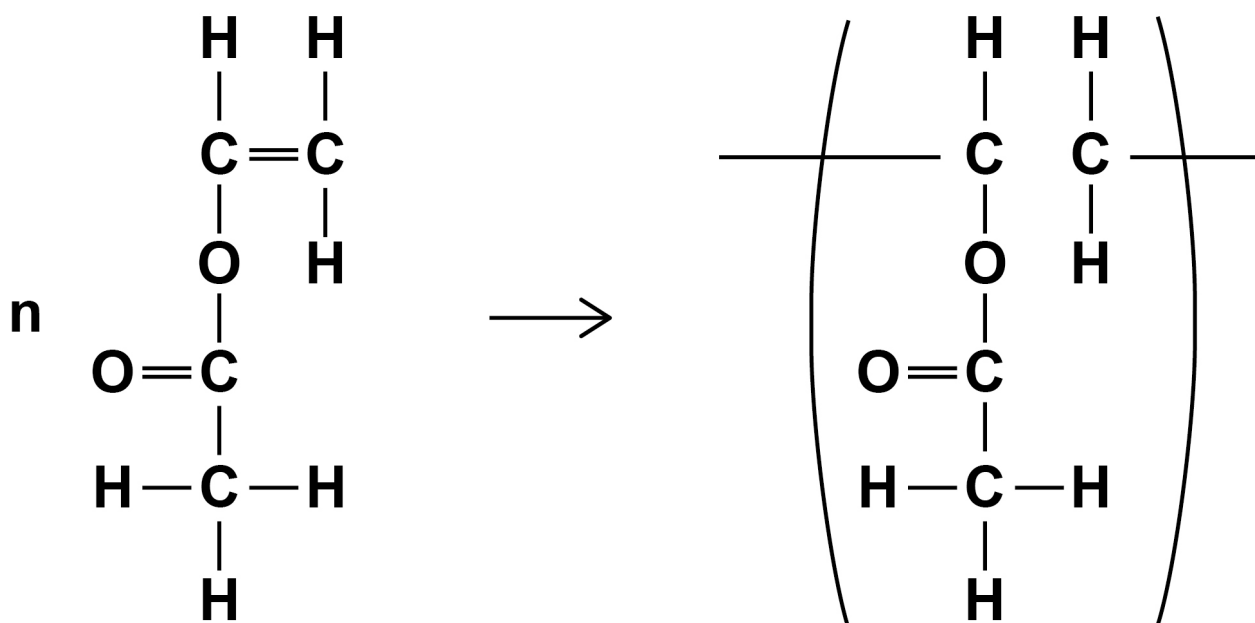
[Turn over]



08.5

Many molecules of compound A join together to form polymer B.

Complete the displayed formula equation which represents this reaction. [2 marks]



08.6

What type of polymer is polymer B? [1 mark]

Tick (✓) ONE box.

Addition polymer

Condensation polymer

DNA

Protein

[Turn over]



Polymer B is a polymer which melts when heated.

08.7

What word is used to describe polymers which melt when heated? [1 mark]

08.8

Explain why some polymers do NOT melt when heated. [2 marks]

13



BLANK PAGE

[Turn over]



09

A student investigated the rate of the reaction between zinc and sulfuric acid.

The equation for the reaction is

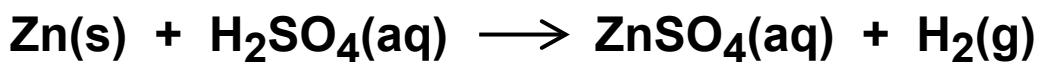
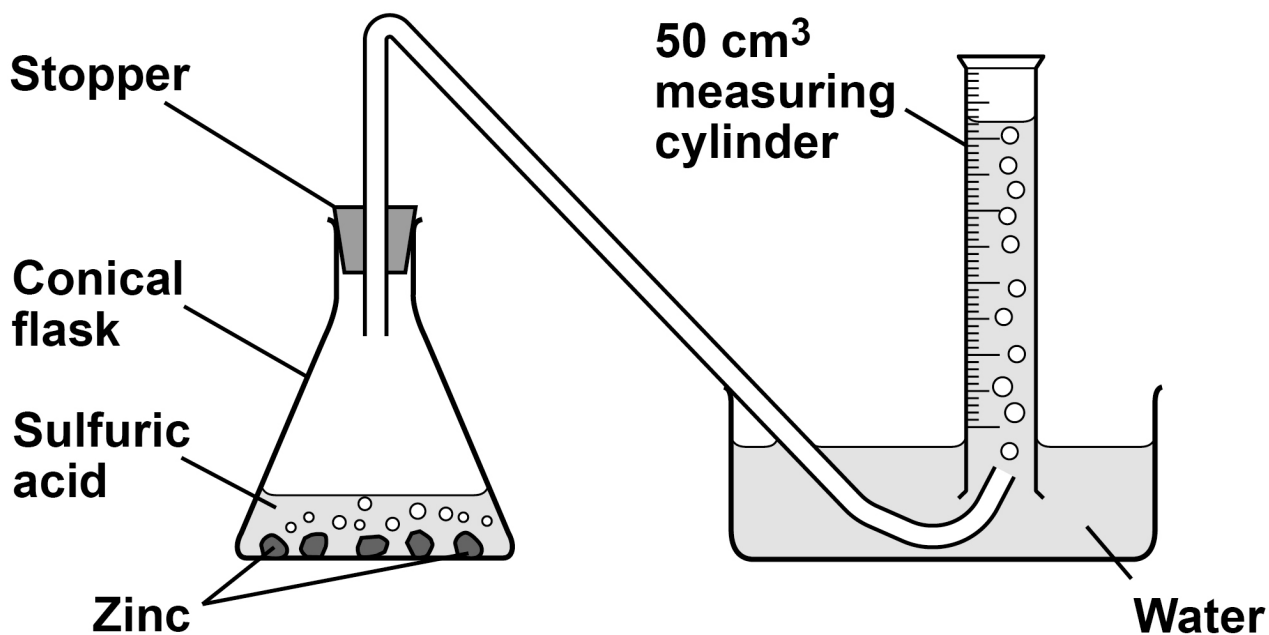


FIGURE 10 shows the apparatus.

FIGURE 10



This is the method used.

1. Pour 50 cm^3 of sulfuric acid into the conical flask.
2. Add excess zinc to the conical flask.
3. Insert the stopper and start a timer.
4. Measure the volume of hydrogen collected in the 50 cm^3 measuring cylinder every 20 seconds for 180 seconds.

09.1

Explain why the volume of hydrogen collected in the 50 cm^3 measuring cylinder is less than the volume of hydrogen produced. [2 marks]

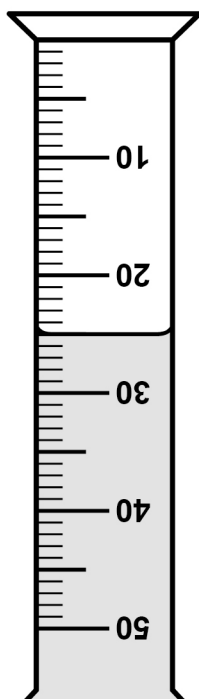
[Turn over]



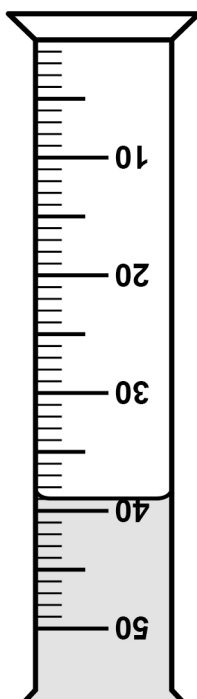
FIGURE 11 shows the volumes of hydrogen collected in the 50 cm³ measuring cylinder after 40 seconds and after 100 seconds.

FIGURE 11

40 seconds



100 seconds



A different student investigated how the concentration of sulfuric acid affected the rate of the reaction.

09.3

The student did a different experiment using sulfuric acid of concentration 0.40 mol/dm³.

The student calculated the number of moles of hydrogen collected after every 20 seconds.

FIGURE 12, on page 70, shows the results.



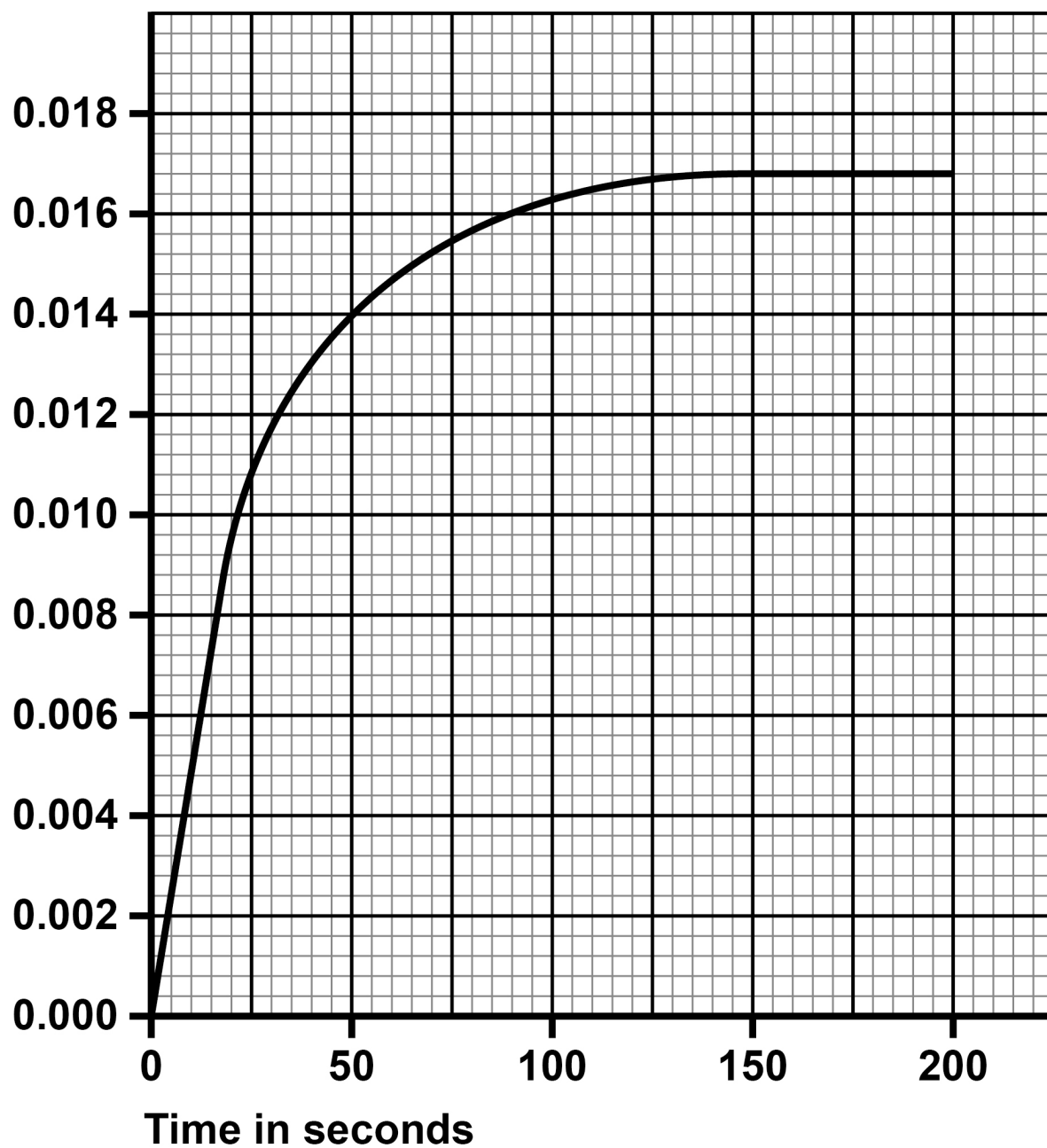
BLANK PAGE

[Turn over]



FIGURE 12

Moles of
hydrogen
collected

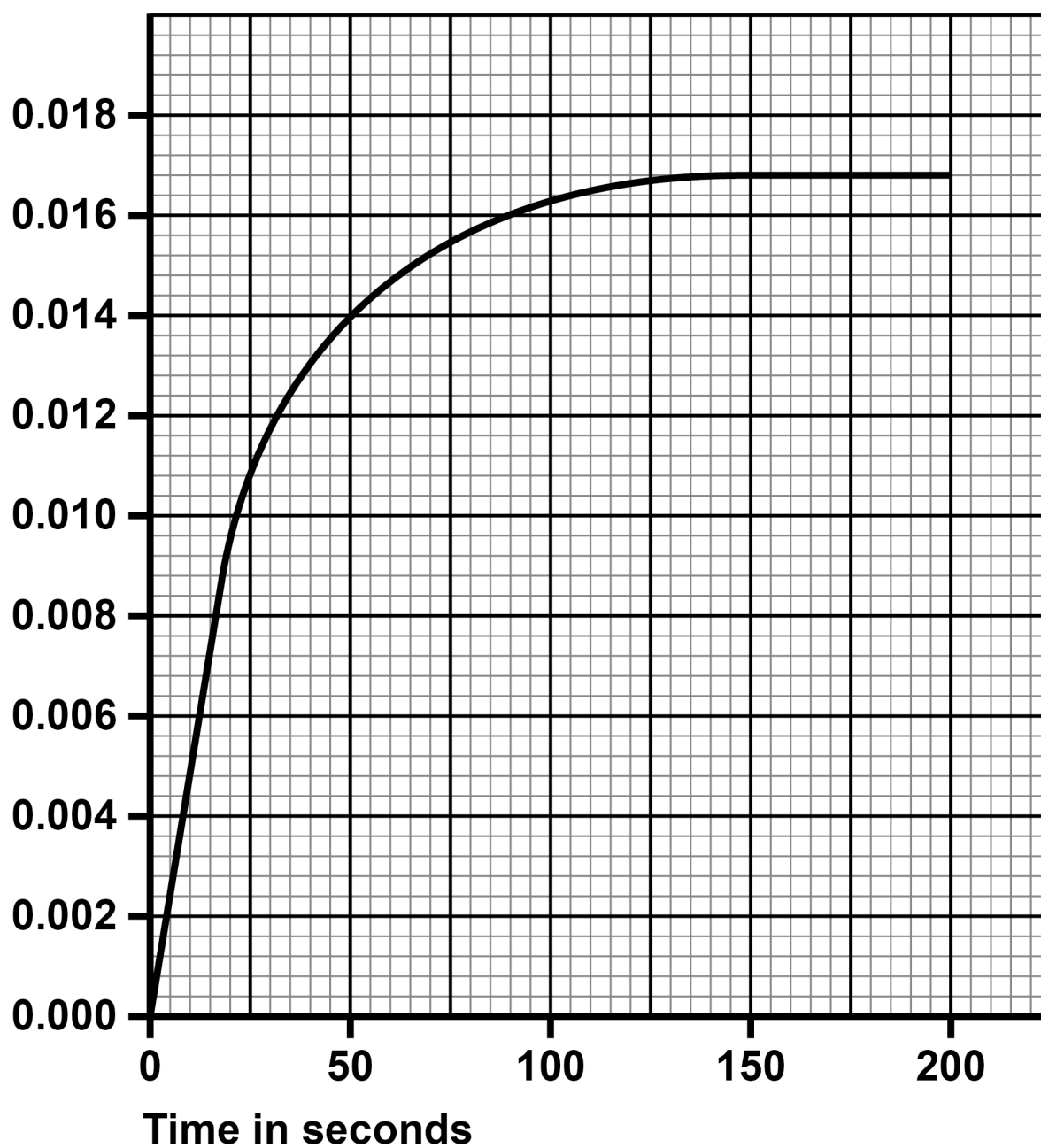


09.4

FIGURE 13 shows the results for 0.40 mol/dm^3 sulfuric acid.

FIGURE 13

Moles of
hydrogen
collected



The student repeated the experiment using 0.20 mol/dm^3 sulfuric acid instead of 0.40 mol/dm^3 sulfuric acid.

Excess zinc was used in each experiment.

Sketch a line on FIGURE 13 to show the results you would expect. [2 marks]

09.5

Explain how increasing the temperature would affect the rate of reaction between zinc and sulfuric acid. [3 marks]

END OF QUESTIONS



BLANK PAGE

For Examiner's Use	
Question	Mark
1	
2	
3	
4	
5	
6	
7	
8	
9	
TOTAL	

Copyright information

For confidentiality purposes, all acknowledgements of third-party copyright material are published in a separate booklet. This booklet is published after each live examination series and is available for free download from www.aqa.org.uk.

Permission to reproduce all copyright material has been applied for. In some cases, efforts to contact copyright-holders may have been unsuccessful and AQA will be happy to rectify any omissions of acknowledgements. If you have any queries please contact the Copyright Team.

Copyright © 2024 AQA and its licensors. All rights reserved.

WP/M/NC/Jun24/8462/2H/G4005/V4

