



Surname _____

Forename(s) _____

Centre Number _____

Candidate Number _____

Candidate Signature _____

I declare this is my own work.

GCSE

MATHEMATICS

H

Higher Tier Paper 2 Calculator

8300/2H

Monday 3 June 2024

Morning

Time allowed: 1 hour 30 minutes

At the top of the page, write your surname and forename(s), your centre number, your candidate number and add your signature.

[Turn over]



J U N 2 4 8 3 0 0 2 H 0 1

MATERIALS

For this paper you must have:

- a calculator
- mathematical instruments
- the Formulae Sheet (enclosed).

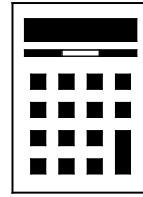

INSTRUCTIONS

- Use black ink or black ball-point pen. Draw diagrams in pencil.
- Answer ALL questions.
- You must answer the questions in the spaces provided. Do not write on blank pages.
- If you need extra space for your answer(s), use the lined pages at the end of this book. Write the question number against your answer(s).
- Do all rough work in this book. Cross through any work you do not want to be marked.



INFORMATION

- The marks for questions are shown in brackets.
- The maximum mark for this paper is 80.
- You may ask for more answer paper, graph paper and tracing paper. These must be tagged securely to this answer book.

ADVICE

In all calculations, show clearly how you work out your answer.

DO NOT TURN OVER UNTIL TOLD TO DO SO



Answer ALL questions in the spaces provided.

- 1 The diagram shows a circle, centre O , and three straight lines.

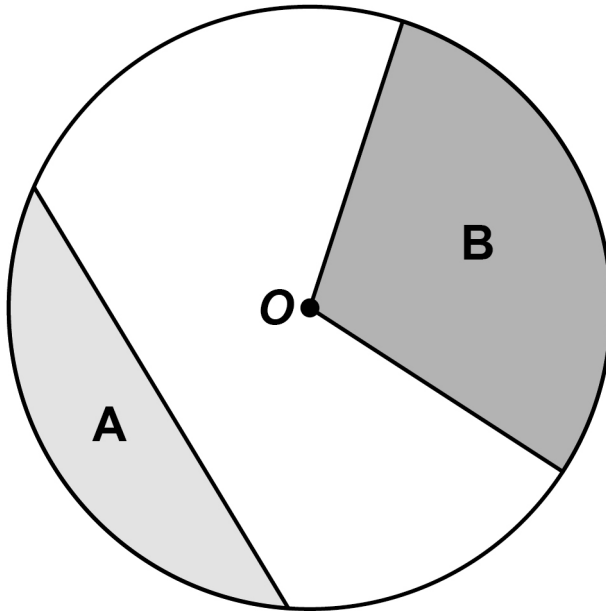

Use ONE word to describe each shaded region.

Choose from

- arc
- chord
- sector
- segment
- tangent

[2 marks]

Region A _____

Region B _____



- 2 The mass of an iceberg is 2 200 000 kg
This value is a 12% reduction from the ORIGINAL mass of the iceberg.

Work out the ORIGINAL mass of the iceberg.

Give your answer in standard form. [3 marks]

Answer _____ kg

[Turn over]

5



3 A chef has a tub of blueberries.

She wants to

- **use all the blueberries**
- **put the same number of blueberries on each dessert.**

$$D = \frac{k}{b}$$

D is the number of desserts.

b is the number of blueberries on each dessert.

3 (a) What does the constant k represent?

Tick the correct box. [1 mark]

The number of blueberries in the tub

The number of desserts

The number of blueberries on each dessert

None of the above



3 (b) Complete the table. [2 marks]

<i>b</i>	2	6	
<i>D</i>	120		30

[Turn over]



4 (a) A fair spinner has six equal sections, each with the number 5, 6, 7 or 8

Each number appears at least once.

$$P(\text{even number}) = P(7)$$

Work out $P(5)$

You may use the blank spinner to help you.
[3 marks]

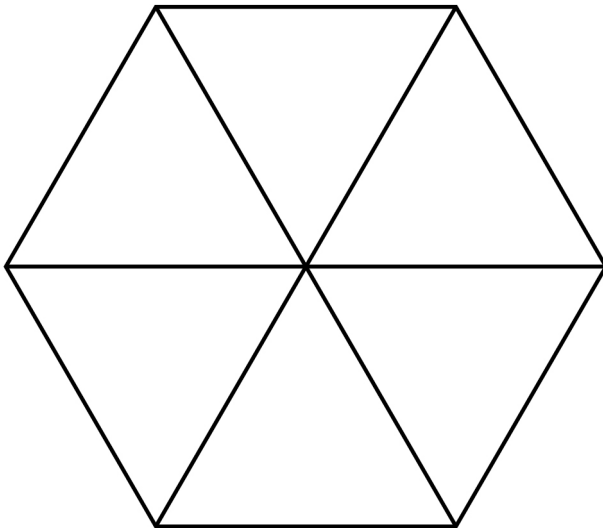

Answer _____

- 4 (b) A different spinner has ten sections, each labelled A, B, C or D.

	A	B	C	D
PROBABILITY	0.1	0.5	0.2	0.3

Give ONE reason why there **MUST** be a mistake in the table. [1 mark]

[Turn over]

<hr/>
7



5 (a) Here is a sketch of the graph $y = -2x + 6$

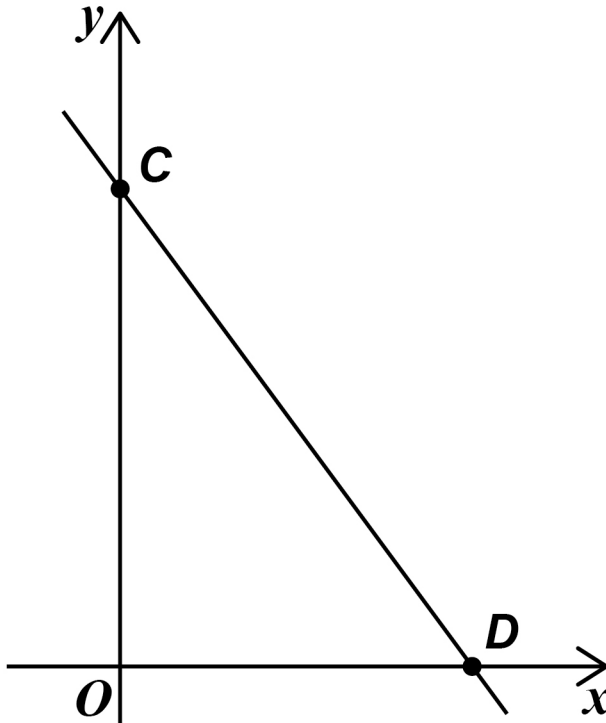

Complete the coordinates of C and D .
[2 marks]

$C (0, \underline{\hspace{2cm}})$ $D (\underline{\hspace{2cm}}, 0)$



5 (b) Here is a sketch of a quadratic graph.

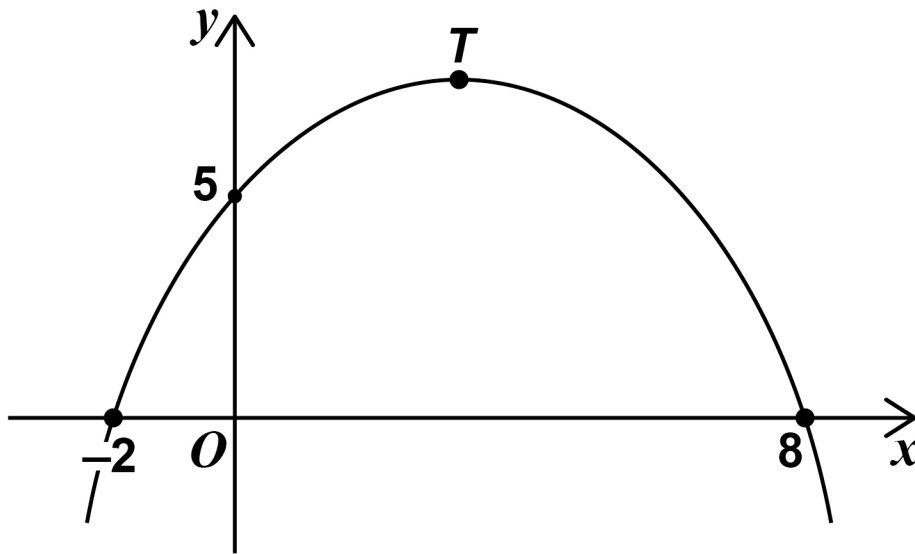

Complete the following statements. [2 marks]

The value of the y -INTERCEPT is

The x -COORDINATE of the turning point, T , is

[Turn over]



6 Work out $(2.5 \times 10^4)^{-3}$

Give your answer in standard form. [1 mark]

Answer _____



7 Archie flips a biased coin 200 times.

Here is some information about the outcomes after each 50 flips.

TOTAL NUMBER OF FLIPS	50	100	150	200
NUMBER OF HEADS	10	27	37	52

Work out the best estimate for the probability of flipping a head.

Give a reason for your answer. [2 marks]

Answer _____

Reason _____

[Turn over]

<hr/>
7



- 8 A lion is sprinting in a straight line away from its den.

The graph shows the lion's distance from the den.

Distance from the den
(metres)

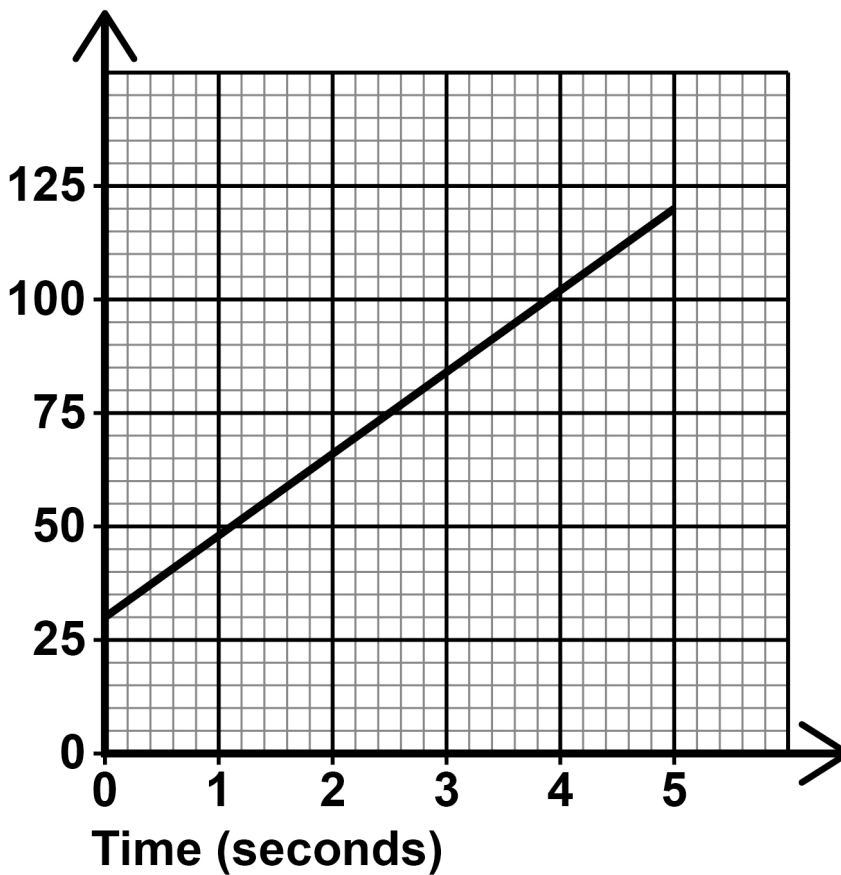

Work out the speed of the lion in metres per second. [3 marks]



Answer _____ **m/s**

[Turn over]



- 9 On the Venn diagram, shade the section represented by $P \cap Q$ [1 mark]

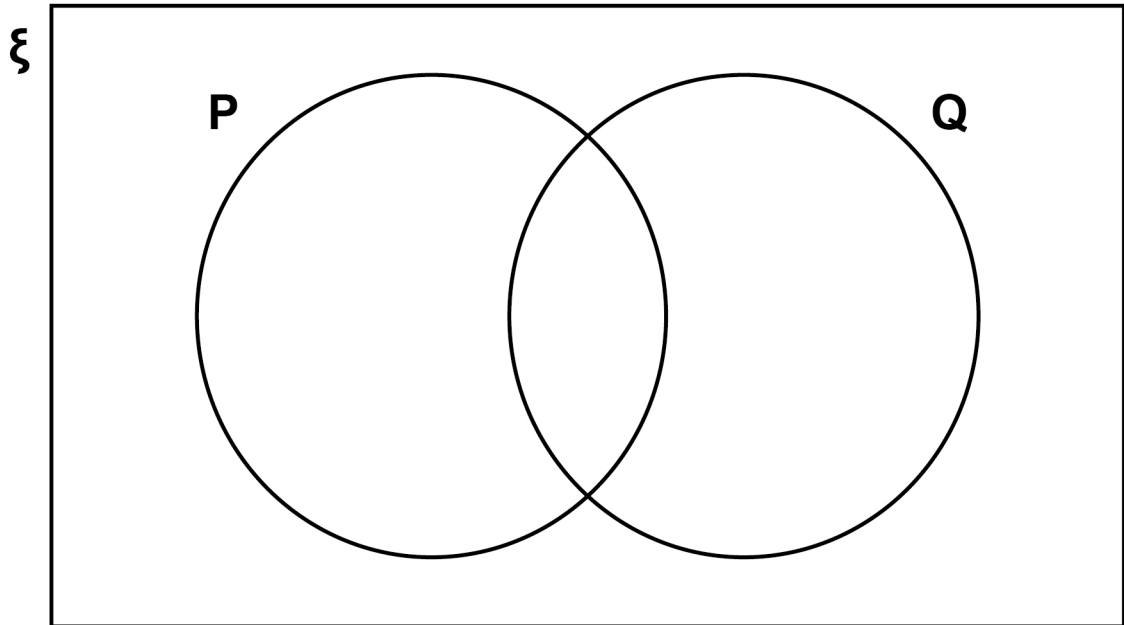

- 10 A bus route had 90 000 passengers last year.

The number of passengers was predicted to increase

by 3% this year

and then

by 8% next year.

Is the predicted number of passengers for NEXT year more than 100 000 ?

You MUST show your working. [3 marks]



12 The diagrams are not drawn accurately.

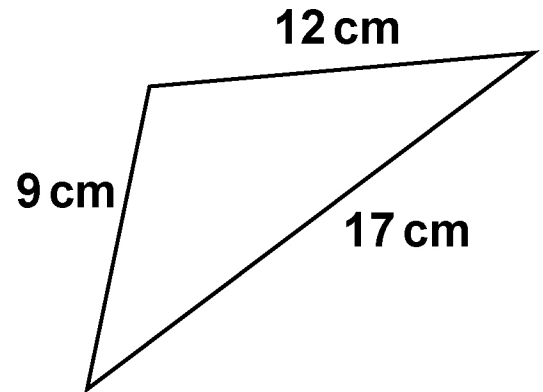
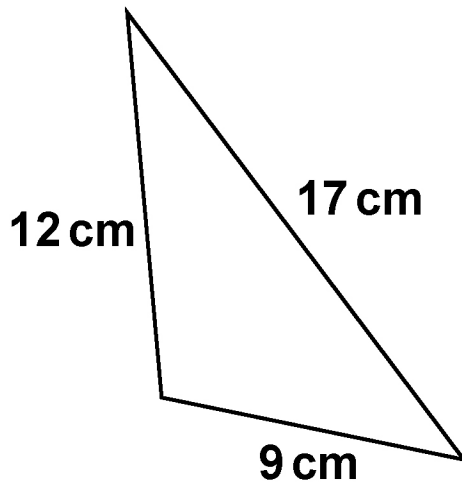

Circle the reason why these triangles are congruent. [1 mark]

ASA

RHS

SAS

SSS

[Turn over]



13 Liam takes part in long jump competitions.

Here is some information about 40 of his jumps.

Length of jump, d metres	Number of jumps	Midpoint	
$7.0 \leq d < 7.4$	15		
$7.4 \leq d < 7.8$	18		
$7.8 \leq d < 8.2$	7		
	Total = 40		

Work out an estimate of the mean distance of these 40 jumps.

Give your answer as a decimal. [3 marks]



Answer _____ m

[Turn over]

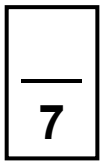

$w =$ _____

14 (b) In fact, the graph is a straight line.

What does this mean about the actual value of w ?

Tick ONE box. [1 mark]

It must be the same as the value in part (a)

It must be different to the value in part (a)

It is impossible to tell

[Turn over]



15 Concrete from a truck is poured at 10.9 kg PER SECOND for 30 minutes.

1000 kg = 1 tonne

Is more than 20 tonnes of concrete poured?

Tick a box.

Yes

No

You MUST show your working. [4 marks]



[Turn over]

8



BLANK PAGE



16 Here is some information about the lengths, in cm, of leaves.

- Shortest length = 2.4
- Longest length = 9
- Upper quartile = 7
- Median length = 6
- Interquartile range = 3

Draw a box plot to show this information.
[3 marks]

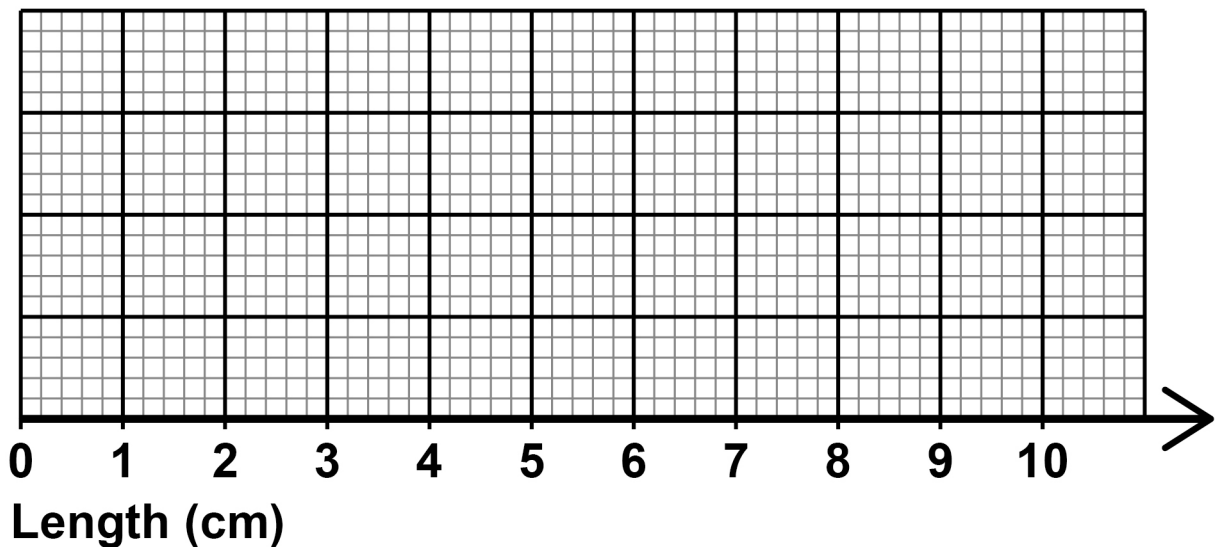

[Turn over]



17 *AB* is a straight line.

Both angles are given in degrees.

The diagram is not drawn accurately.

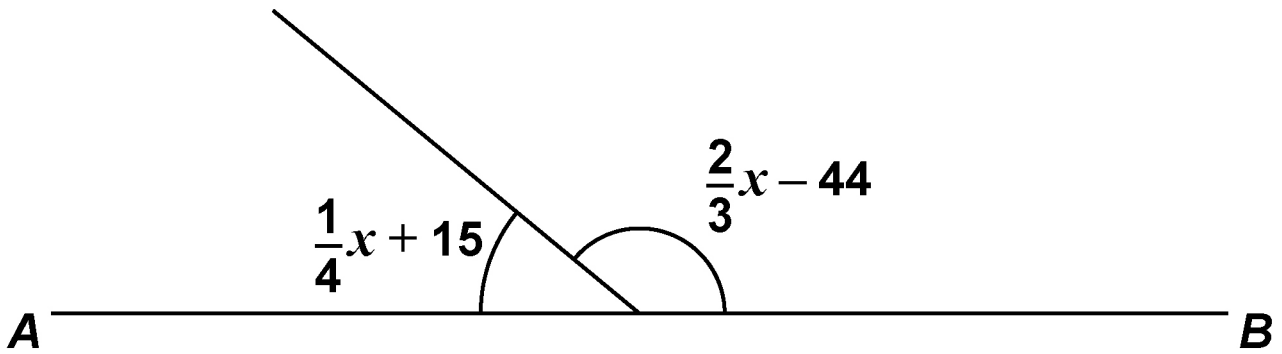

By working out the value of x ,

work out the ratio smaller angle : larger angle
[4 marks]



18 A diagonal of a rectangle is 23.7 cm long.

The diagonal makes an angle of 52° with a side of length x cm

Work out the value of x . [3 marks]



$x =$ _____

[Turn over]



d = _____

e = _____

f = _____

[Turn over]



21 People in a stadium are in the North Stand, East Stand, South Stand or West Stand.

Of the people in the stadium,

$\frac{1}{4}$ are in the North Stand

$\frac{3}{10}$ are in the East Stand

**number in South Stand : number in West Stand
= 2 : 7**

There are 4480 people in the West Stand.

How many people are in the stadium? [4 marks]

Answer _____

[Turn over]

8



$x =$ _____

[Turn over]

23 The diagram is not drawn accurately.

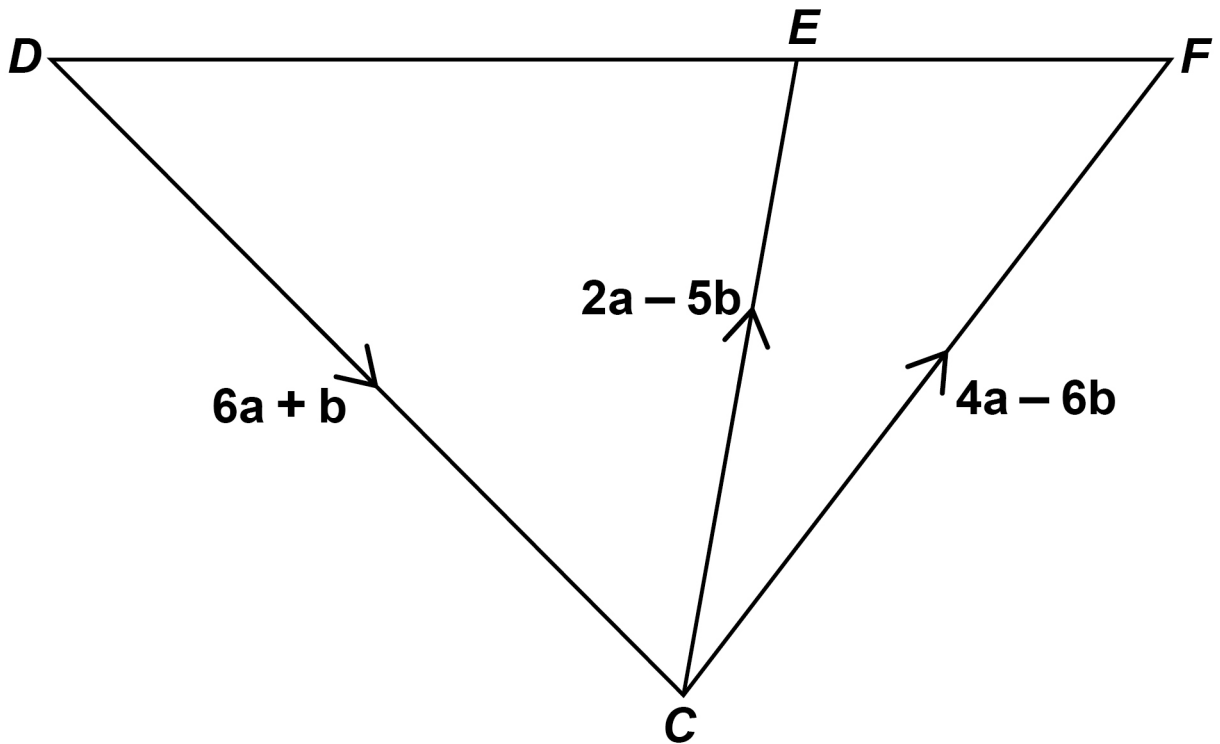

Prove that DEF is a straight line. [4 marks]



- 24 A room is kept at a constant temperature of $21\text{ }^{\circ}\text{C}$ for 6 hours.

The heating is then turned off and the room begins to cool.

Here is a sketch graph showing the temperature, $y\text{ }^{\circ}\text{C}$, of the room at time x hours.

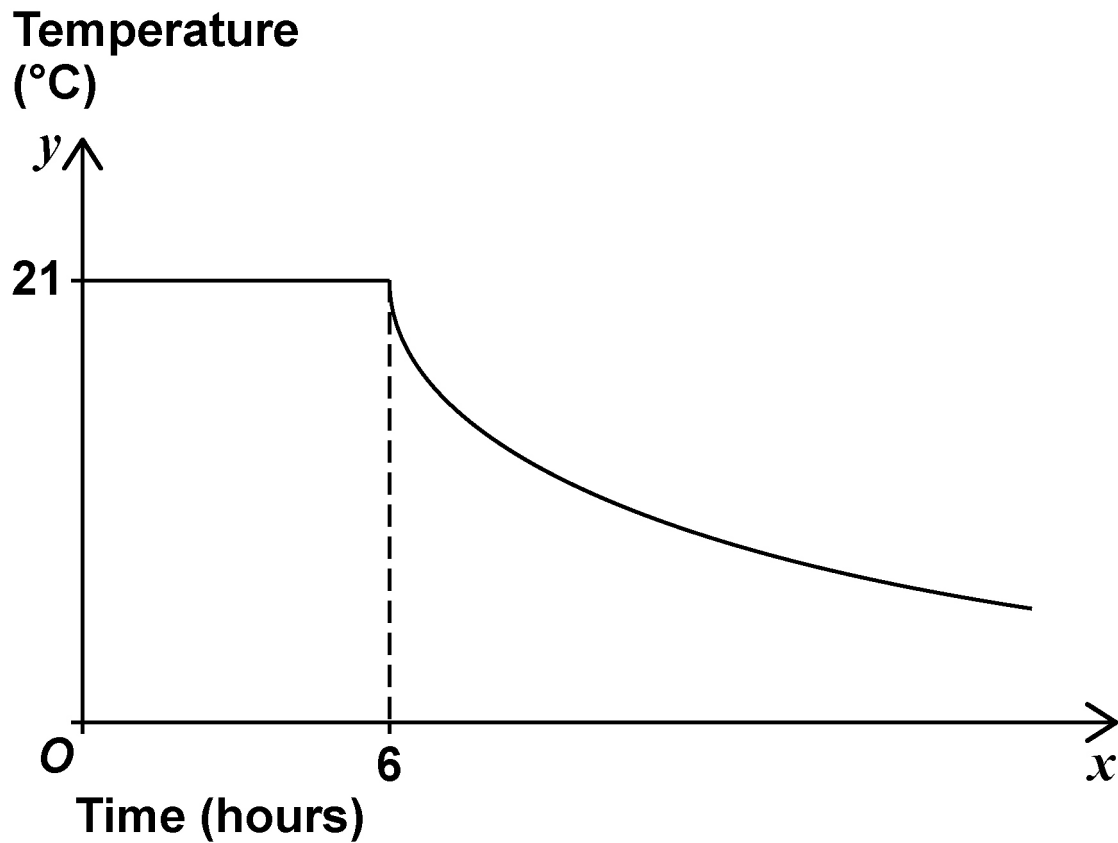

24 (a) Assume the equation of the curved part is

$$y = \frac{k}{x} \text{ where } k \text{ is a constant.}$$

Work out the value of y when $x = 12$ [2 marks]

$y =$ _____

[Turn over]



24 (b) In fact,
the equation of the curved part is

$y = A \times \left(\frac{1}{3}\right)^{\frac{1}{6}x}$ where A is a DIFFERENT
constant.

How does this affect the value of y when
 $x = 12$?

Tick ONE box.

You MUST show working to support your
answer. [2 marks]

The value of y is greater than the
answer to part (a).

The value of y is less than the answer
to part (a).

The value of y is the same as the
answer to part (a).



[Turn over]

4



25 Here is a right-angled triangular prism.

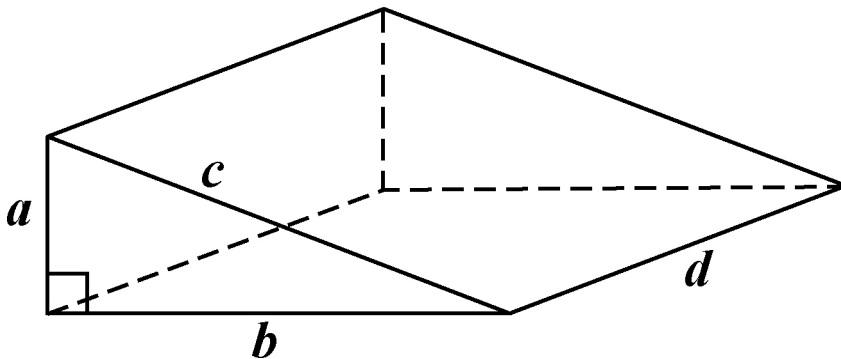

The ratio of the edges is $a : b : c : d = 3 : 4 : 5 : 12$

The VOLUME of the prism is 1125 cm^3

Work out the total length of ALL of the edges of the prism. [5 marks]

BLANK PAGE

For Examiner's Use	
Pages	Mark
4–5	
6–9	
10–13	
14–17	
18–21	
22–25	
27–29	
30–33	
34–37	
38–41	
42–45	
46–47	
TOTAL	

Copyright information

For confidentiality purposes, all acknowledgements of third-party copyright material are published in a separate booklet. This booklet is published after each live examination series and is available for free download from www.aqa.org.uk.

Permission to reproduce all copyright material has been applied for. In some cases, efforts to contact copyright-holders may have been unsuccessful and AQA will be happy to rectify any omissions of acknowledgements. If you have any queries please contact the Copyright Team.

Copyright © 2024 AQA and its licensors. All rights reserved.

WP/M/SB/Jun24/8300/2H/G4007/V4

