



Surname _____

Forename(s) _____

Centre Number _____

Candidate Number _____

Candidate Signature _____

I declare this is my own work.

GCSE

COMBINED SCIENCE: SYNERGY

F

Foundation Tier Paper 3

Physical Sciences

8465/3F

Friday 7 June 2024 Afternoon

Time allowed: 1 hour 45 minutes

At the top of the page, write your surname and forename(s), your centre number, your candidate number and add your signature.

[Turn over]



J U N 2 4 8 4 6 5 3 F 0 1

MATERIALS

For this paper you must have:

- **a ruler**
- **a protractor**
- **a scientific calculator**
- **the periodic table (enclosed)**
- **the Physics Equations Sheet (enclosed).**

INSTRUCTIONS

- **Use black ink or black ball-point pen.**
- **Pencil should only be used for drawing.**
- **Answer ALL questions in the spaces provided. Do not write on blank pages.**
- **If you need extra space for your answer(s), use the lined pages at the end of this book. Write the question number against your answer(s).**
- **Do all rough work in this book. Cross through any work you do not want to be marked.**



- **In all calculations, show clearly how you work out your answer.**

INFORMATION

- **The maximum mark for this paper is 100.**
- **The marks for questions are shown in brackets.**
- **You are expected to use a calculator where appropriate.**
- **You are reminded of the need for good English and clear presentation in your answers.**

DO NOT TURN OVER UNTIL TOLD TO DO SO



0	1
---	---

This question is about the periodic table and the elements in Group 0.

0	1	.	1
---	---	---	---

Complete the sentence.

Choose the answer from the list. [1 mark]

ATOMIC NUMBER

MASS NUMBER

NEUTRON NUMBER

The elements in the periodic table are arranged in

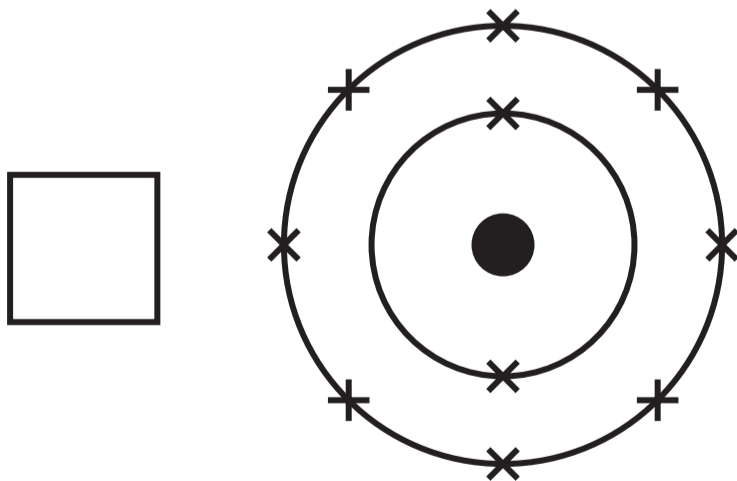
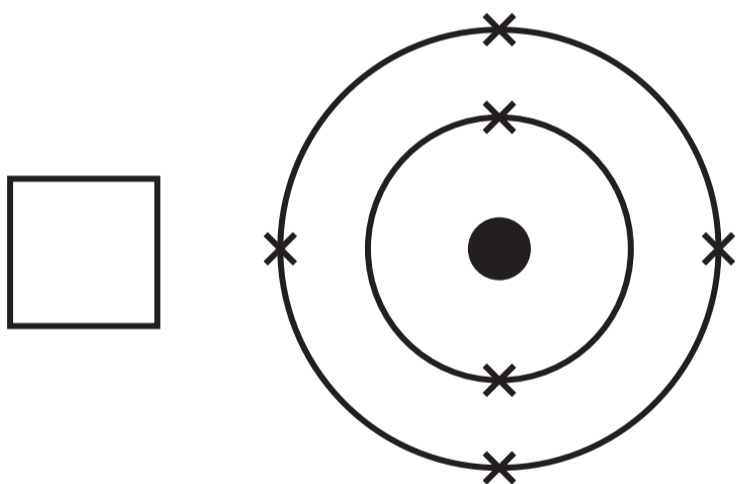
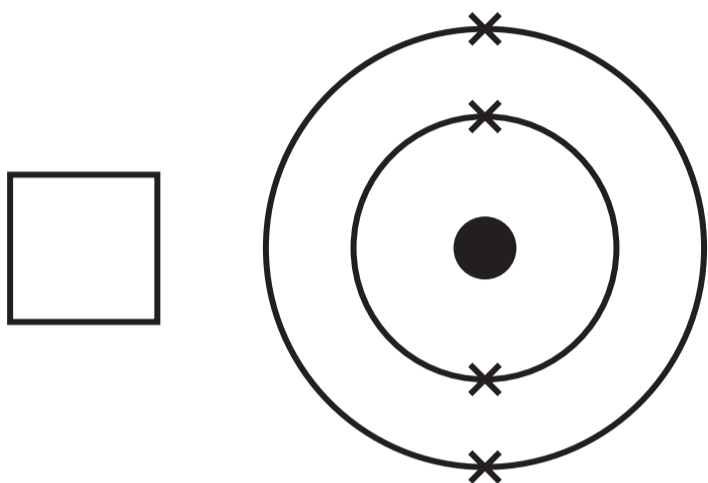
order of _____.



0 1 . 2

Which electronic structure represents an atom of an element in Group 0? [1 mark]

Tick (✓) ONE box.



[Turn over]



0 1 . 3

Which is a property of the elements in Group 0? [1 mark]

Tick (✓) ONE box.

Are unreactive

Conduct electricity

Consist of molecules



TABLE 1 shows the relative atomic masses (A_r) and the boiling points of some elements in Group 0.

TABLE 1

ELEMENT	RELATIVE ATOMIC MASS (A_r)	BOILING POINT IN °C
Helium	4	-269
Neon	20	-246
Z	40	X
Krypton	84	-153
Xenon	131	-108

[Turn over]



0 1 . 4

What is the state of the elements in Group 0 at room temperature?

Use TABLE 1, on page 7. [1 mark]

0 1 . 5

Complete the sentence.

Use TABLE 1. [1 mark]

The boiling points of elements in Group 0 increase as the relative atomic masses



0 1 . 6

**What is value X in TABLE 1, on page 7?
[1 mark]**

Tick (✓) ONE box.

−100 °C

−131 °C

−186 °C

−252 °C

[Turn over]



TABLE 1, is repeated here.

ELEMENT	RELATIVE ATOMIC MASS (A_r)	BOILING POINT IN °C
Helium	4	-269
Neon	20	-246
Z	40	X
Krypton	84	-153
Xenon	131	-108

0 1 . 7

Identify element Z in TABLE 1, repeated above.

Use the periodic table. [1 mark]

7



BLANK PAGE

[Turn over]



0	2
---	---

This question is about hydrocarbons.

0	2	.	1
---	---	---	---

Name the TWO elements in a hydrocarbon. [2 marks]

1 _____

2 _____



0 2 . 2

Which TWO of the following substances are hydrocarbons? [2 marks]

Tick (✓) TWO boxes.

Ammonia

Ethene

Graphite

Methane

Steam

[Turn over]



C_6H_{14} is a hydrocarbon.

C_6H_{14} can be broken down into smaller molecules.

0 2 . 3

Complete the equation for the breakdown of C_6H_{14} into smaller molecules. [1 mark]



02.4

What is the name of the process that breaks down C_6H_{14} into smaller molecules? [1 mark]

Tick (✓) ONE box.

Cracking

Distillation

Neutralisation

[Turn over]



0	2	.	5
---	---	---	---

How does the boiling point of C_6H_{14} compare with the boiling point of C_4H_{10} ?

Give ONE reason for your answer.
[2 marks]

Tick (✓) ONE box.

C_6H_{14} has a lower boiling point.

C_6H_{14} and C_4H_{10} have the same boiling point.

C_6H_{14} has a higher boiling point.

Reason _____



The complete combustion of C_6H_{14} produces water and ONE other product.

0 2 . 6

Name the OTHER product of the complete combustion of C_6H_{14}

Do NOT refer to water in your answer.
[1 mark]

[Turn over]



0	2	.	7
---	---	---	---

The formula of water is H_2O

Calculate the relative formula mass (M_r) of water.

Relative atomic masses (A_r):

$\text{H} = 1$ $\text{O} = 16$

[2 marks]

$M_r =$ _____

11



BLANK PAGE

[Turn over]



0	3
---	---

FIGURE 1 shows two people wearing inflatable bodysuits.

The bodysuits are made of soft plastic and are inflated with air.

The inflatable bodysuits allow the two people to collide with each other safely.

FIGURE 1

**Inflatable
bodysuit**

Person



The two people run towards each other before colliding and coming to a stop.



People wearing bodysuits take more time to stop during a collision than people not wearing bodysuits.

0 3 . 1

How does wearing bodysuits affect the deceleration of the people during the collision? [1 mark]

Tick (✓) ONE box.

The deceleration is less.

The deceleration is the same.

The deceleration is greater.

[Turn over]



03.2

How does wearing bodysuits affect the impact force experienced by each person during the collision? [1 mark]

Tick (✓) ONE box.

The impact force is less.

The impact force is the same.

The impact force is greater.



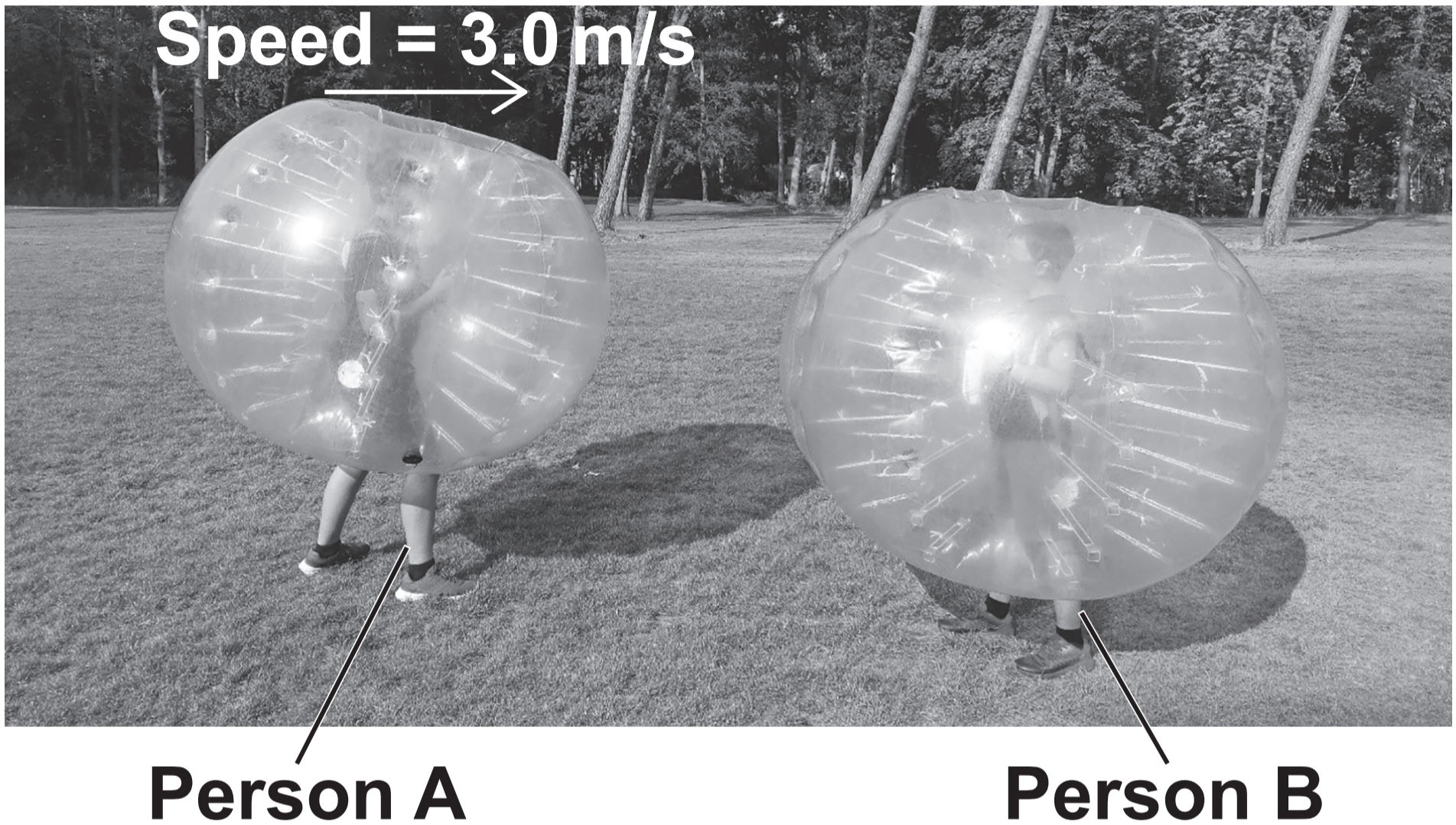
BLANK PAGE

[Turn over]



FIGURE 2 shows person A about to collide with person B.

FIGURE 2



0	3	.	3
---	---	---	---

Person A has a mass of 60 kg.

Person A moves with a speed of 3.0 m/s.

Calculate the kinetic energy of person A.

Use the equation:

kinetic energy = $0.5 \times \text{mass} \times (\text{speed})^2$
[2 marks]

Kinetic energy = _____ J

[Turn over]



03.4

After the collision, person B has 45 J of kinetic energy.

Person B has a mass of 40 kg.

Calculate the speed of person B after the collision.

Use the equation:

$$\text{speed} = \sqrt{\frac{2 \times \text{kinetic energy}}{\text{mass}}}$$

[2 marks]



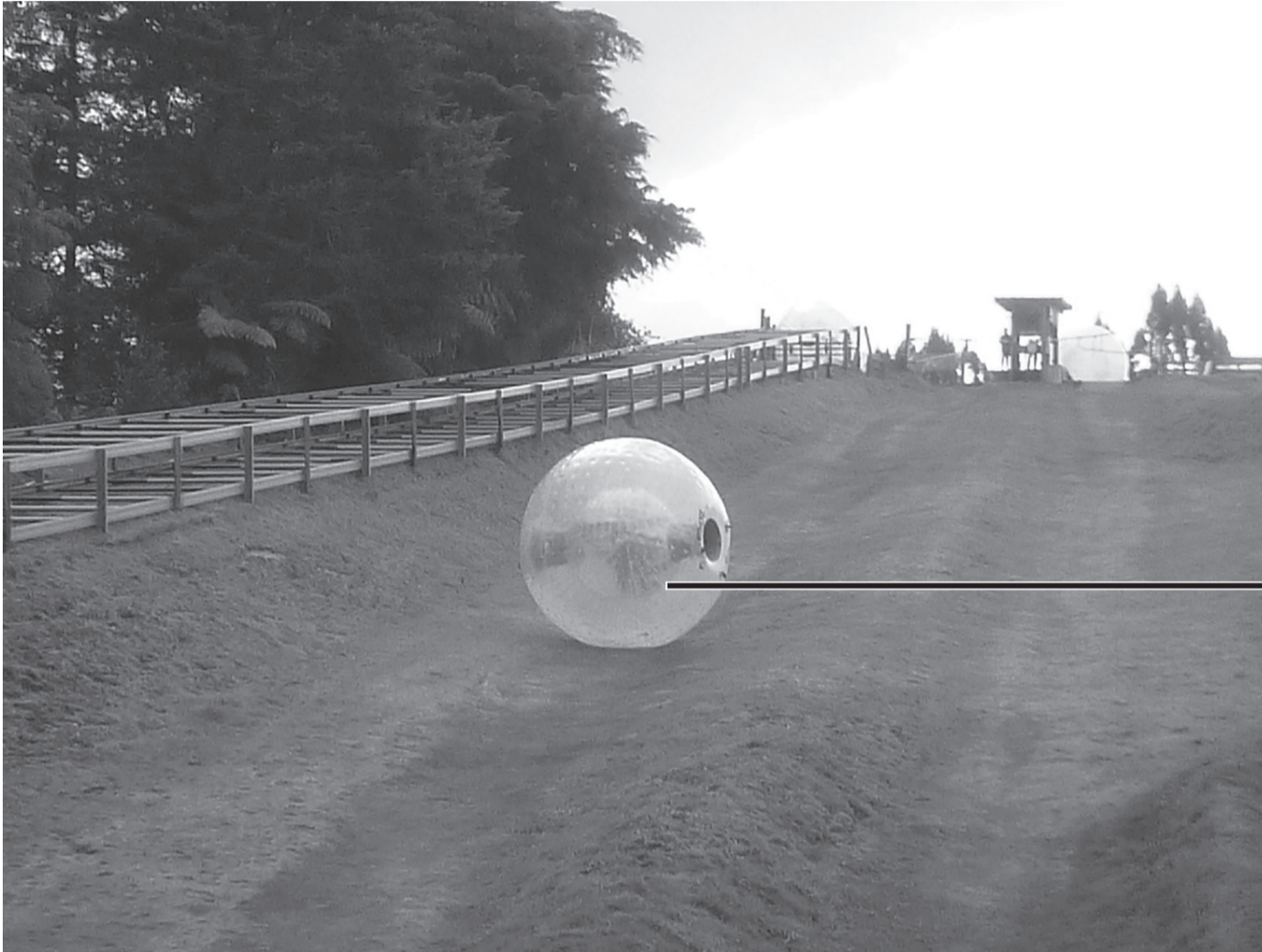
Speed = _____ m/s

[Turn over]



FIGURE 3 shows a person in an inflatable sphere rolling down a hill.

FIGURE 3



**Person in
inflatable
sphere**



0	3	.	5
---	---	---	---

**Describe how the gravitational potential energy AND kinetic energy of the person vary as the sphere rolls down the hill.
[2 marks]**

[Turn over]



03.6

Suggest TWO factors that affect the maximum speed of the person as the sphere reaches the bottom of the hill.
[2 marks]

1 _____

2 _____

10



BLANK PAGE

[Turn over]



0	4
---	---

This question is about life cycle assessments (LCAs).

LCAs assess the environmental impact of a product.

0	4	.	1
---	---	---	---

An LCA has four stages.

Complete the sentences on page 33.

Choose answers from the list. [2 marks]

DISPOSED OF

EXTRACTED

MANUFACTURED

PACKAGED



The first stage of an LCA assesses how raw materials are

The final stage of an LCA assesses how the product is

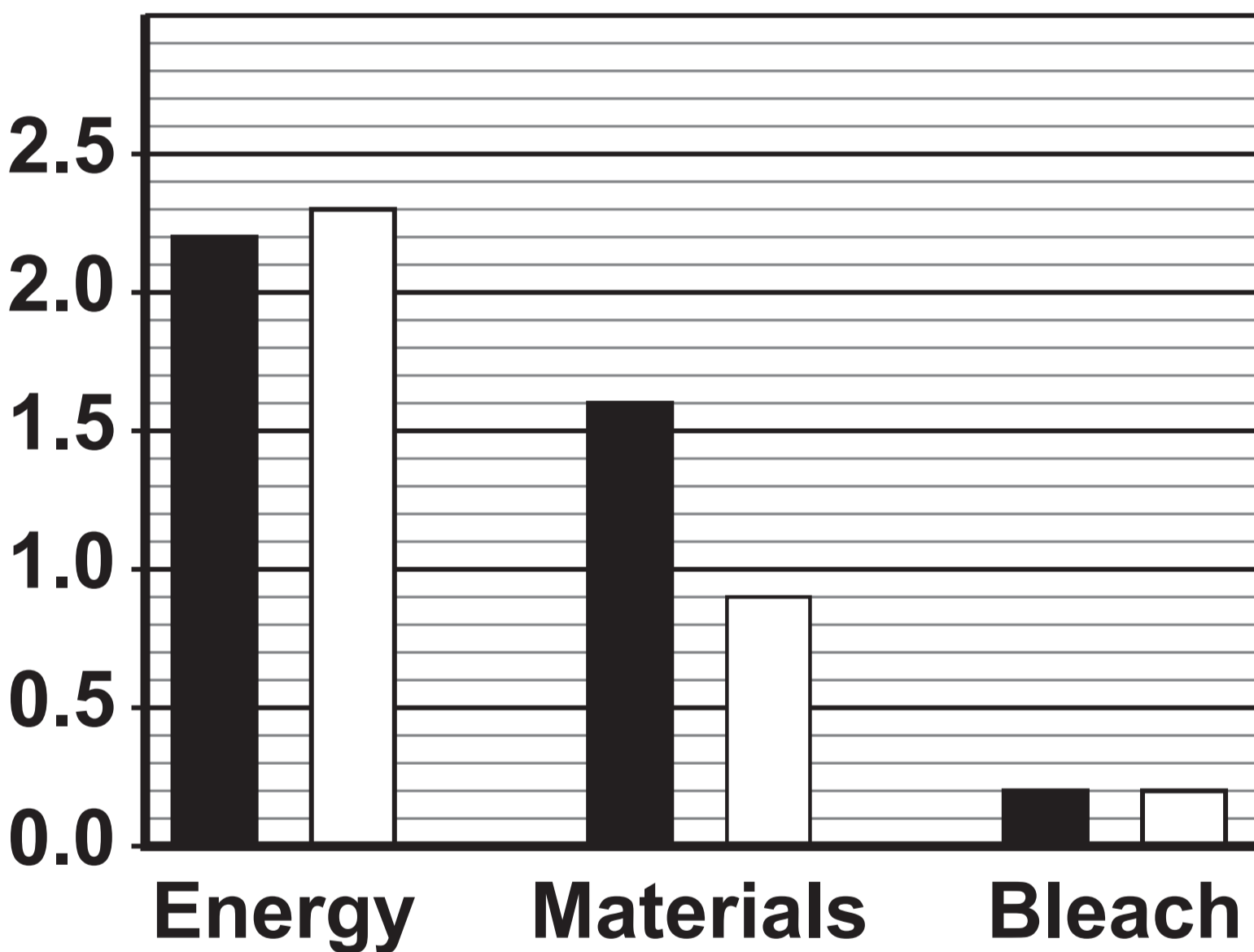
[Turn over]



FIGURE 4 shows the environmental impact of the use of energy, materials and bleach during the production of two different shirts.

FIGURE 4

Environmental impact in arbitrary units



KEY

■ Shirt A

□ Shirt B



04.2

Draw **ONE** line from each statement to the cause of the environmental impact.

Use **FIGURE 4**, on the opposite page.
[2 marks]

STATEMENT	CAUSE OF THE ENVIRONMENTAL IMPACT
Has the greatest environmental impact for both shirts	Energy
Has the biggest difference in environmental impact between the two shirts	Materials
	Bleach

[Turn over]



0 4 . 3

The total environmental impact of producing shirt A is 4.0 arbitrary units.

Determine the percentage of the total environmental impact of producing shirt A that is caused by ENERGY use.

You should:

- **give the environmental impact caused by energy use for shirt A**
- **calculate the percentage of the total environmental impact caused by energy use for shirt A.**

Use FIGURE 4, on page 34. [3 marks]



Environmental impact =

_____ **arbitrary units**

Percentage = _____ **%**

[Turn over]



0	4	.	4
---	---	---	---

LCAs should be peer reviewed by independent scientists.

Give ONE reason why the peer review should be independent. [1 mark]

8



BLANK PAGE

[Turn over]



0	5
---	---

Energy resources are renewable or non-renewable.

0	5	.	1
---	---	---	---

Which TWO of the following energy resources are renewable? [2 marks]

Tick (✓) TWO boxes.

Biofuel

Coal

Nuclear

Oil

Wind



BLANK PAGE

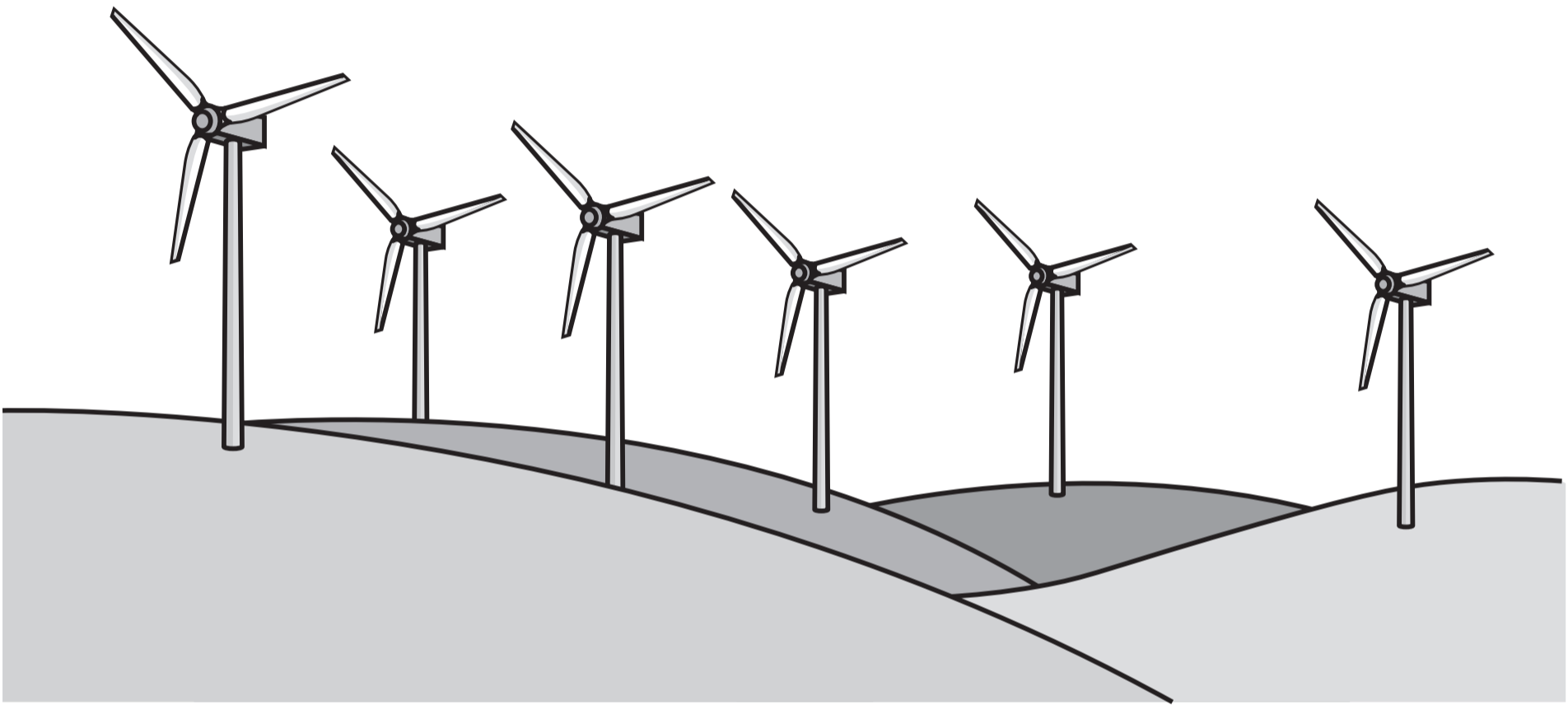
[Turn over]



0 5 . 2

FIGURE 5 shows wind turbines in the countryside.

FIGURE 5



What are TWO effects on the environment of using wind turbines to generate electricity? [2 marks]

Tick (✓) TWO boxes.

Some birds are killed by wind turbines.

There is no fuel cost when using wind turbines.

Wind is an unreliable energy resource.

Wind turbines generate lots of electricity in windy conditions.

Wind turbines produce low frequency noise.

[Turn over]



FIGURE 6 shows a wind turbine.

FIGURE 6



0 5 . 3

The useful power output of the generator in the wind turbine is 144 000 W.

The efficiency of the wind turbine is 0.30

Calculate the total power input to the wind turbine.

Use the equation:

$$\text{total power input} = \frac{\text{useful power output}}{\text{efficiency}}$$

[2 marks]

Total power input = _____ W

[Turn over]



Use the Physics Equations Sheet to answer Questions 05.4 and 05.5.

0 5 . 4

Which equation links current, potential difference and power? [1 mark]

Tick (✓) ONE box.

power = potential difference × current

power = $\frac{\text{potential difference}}{\text{current}}$

power = $\frac{\text{current}}{\text{potential difference}}$

0 5 . 5

The power output of the generator in the wind turbine is 144 000 W.

The potential difference across the generator is 960 V.



**Calculate the current in the generator.
[3 marks]**

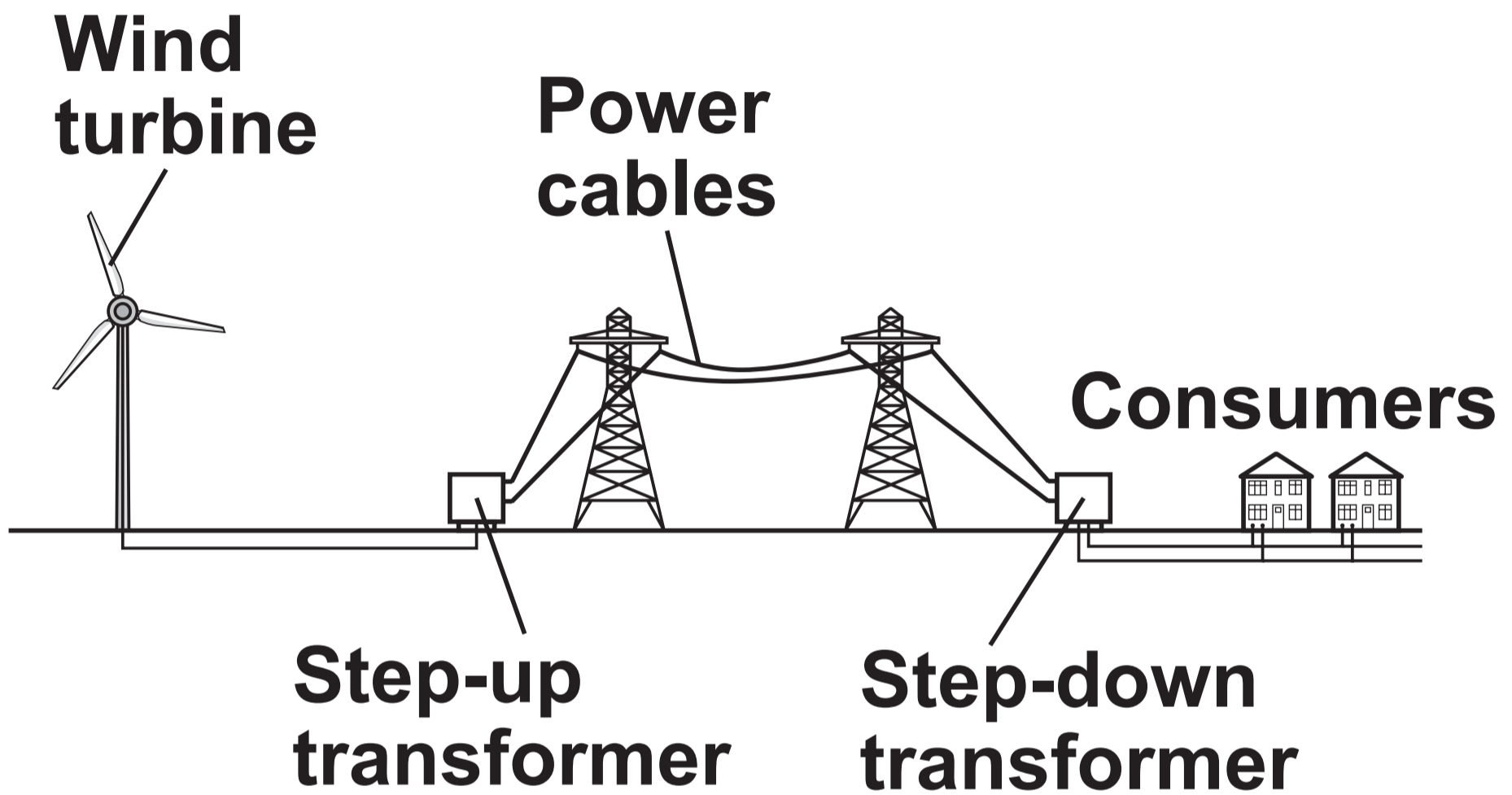
Current = _____ A

[Turn over]



FIGURE 7 shows how the National Grid links the wind turbine to consumers.

FIGURE 7



0	5	.	6
---	---	---	---

The step-up transformer increases the potential difference and decreases the current.

What effect does decreasing the current have on the energy loss from the power cables? [1 mark]

Tick (✓) ONE box.

The energy loss decreases.

The energy loss is not affected.

The energy loss increases.

[Turn over]



0	5	.	7
---	---	---	---

**What is the function of the step-down transformer in FIGURE 7, on page 48?
[1 mark]**

Tick (✓) ONE box.

To decrease the current.

To decrease the potential difference.

To decrease the power input.

12



BLANK PAGE

[Turn over]



0	6
---	---

This question is about the elements magnesium, oxygen and lithium.

0	6	.	1
---	---	---	---

What is the type of bonding in magnesium? [1 mark]

Tick (✓) ONE box.

Covalent

Ionic

Metallic



0	6	.	2
---	---	---	---

What is the type of bonding in oxygen?
[1 mark]

Tick (✓) ONE box.

Covalent

Ionic

Metallic

[Turn over]



0 6 . 3

Magnesium atoms react with oxygen atoms to produce magnesium oxide.

Magnesium oxide contains magnesium ions and oxide ions.

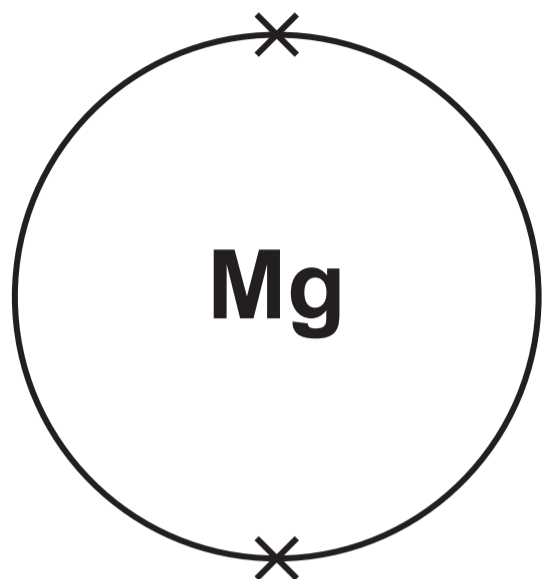
FIGURE 8, on the opposite page, shows the electronic structure of the atoms and the ions.

Only the outer shell electrons are shown.

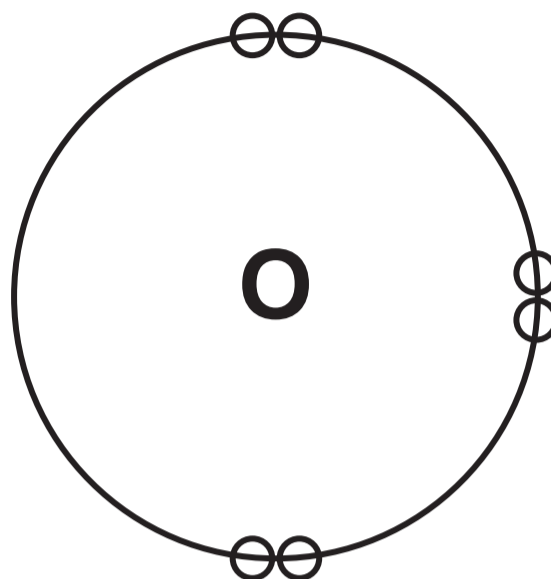


FIGURE 8

Magnesium atom



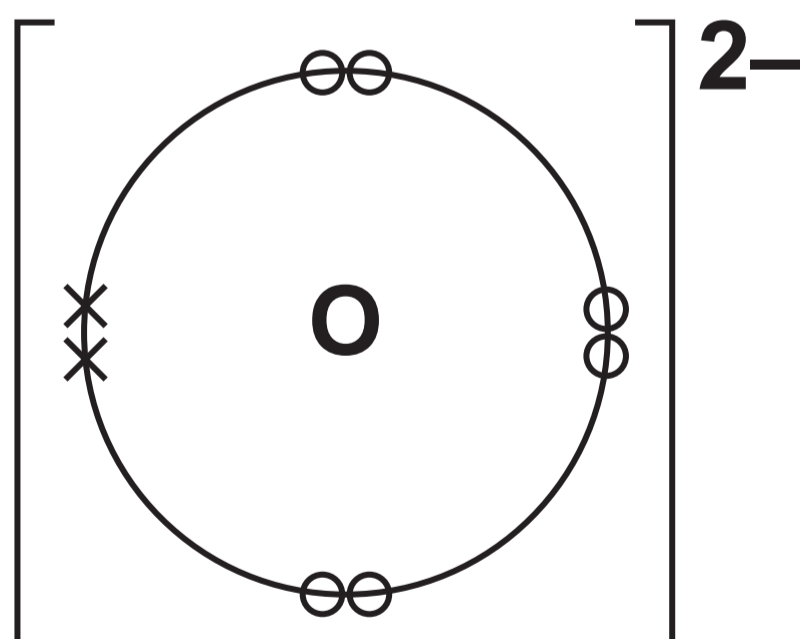
Oxygen atom



Magnesium ion



Oxide ion



[Turn over]



[Turn over]

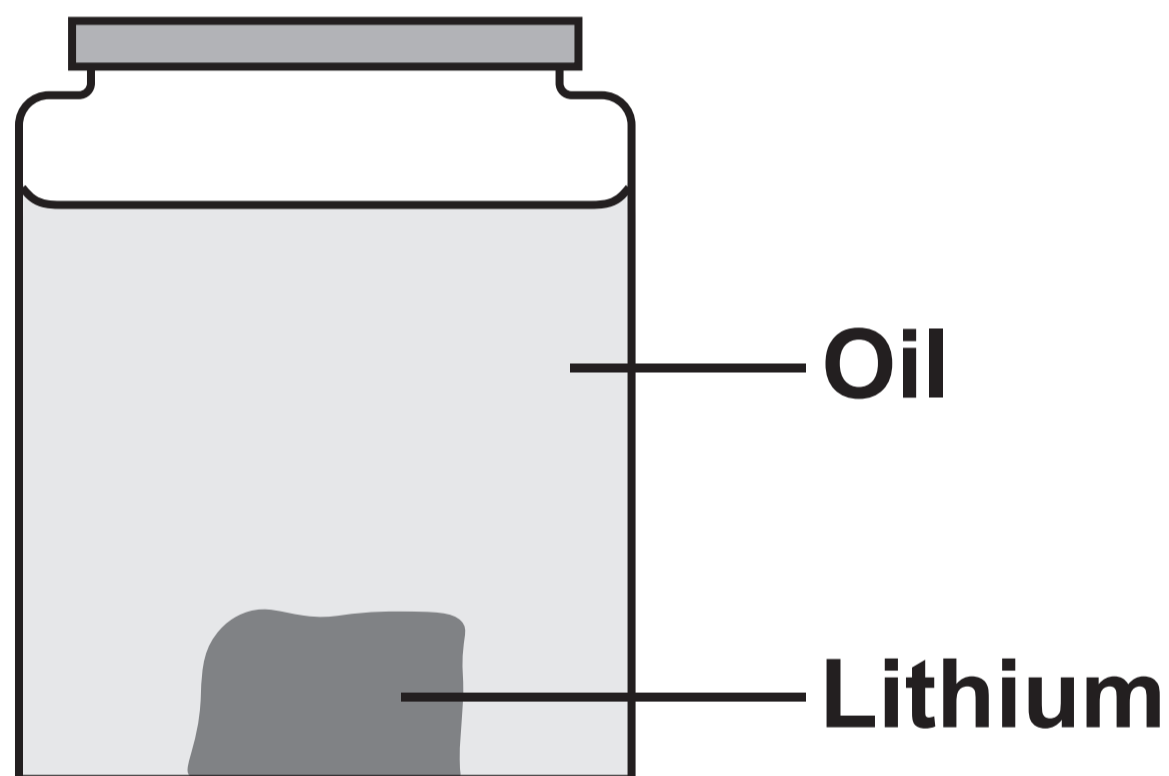


Lithium is an element in Group 1 of the periodic table.

0 6 . 4

FIGURE 9 shows a piece of lithium stored in oil.

FIGURE 9



Suggest why lithium is stored in oil.
[1 mark]



A teacher reacted 0.5 g of lithium with oxygen.

The teacher measured the mass of lithium oxide produced.

The teacher repeated the experiment with different masses of lithium.

TABLE 2 shows the results.

TABLE 2

MASS OF LITHIUM REACTED IN GRAMS	MASS OF LITHIUM OXIDE PRODUCED IN GRAMS
0.5	1.0
1.0	2.1
1.5	3.1
2.0	4.2
2.5	5.2

[Turn over]



0	6	.	5
---	---	---	---

Describe the relationship between the mass of lithium reacted and the mass of lithium oxide produced. [1 mark]

0	6	.	6
---	---	---	---

Complete FIGURE 10, on the opposite page.

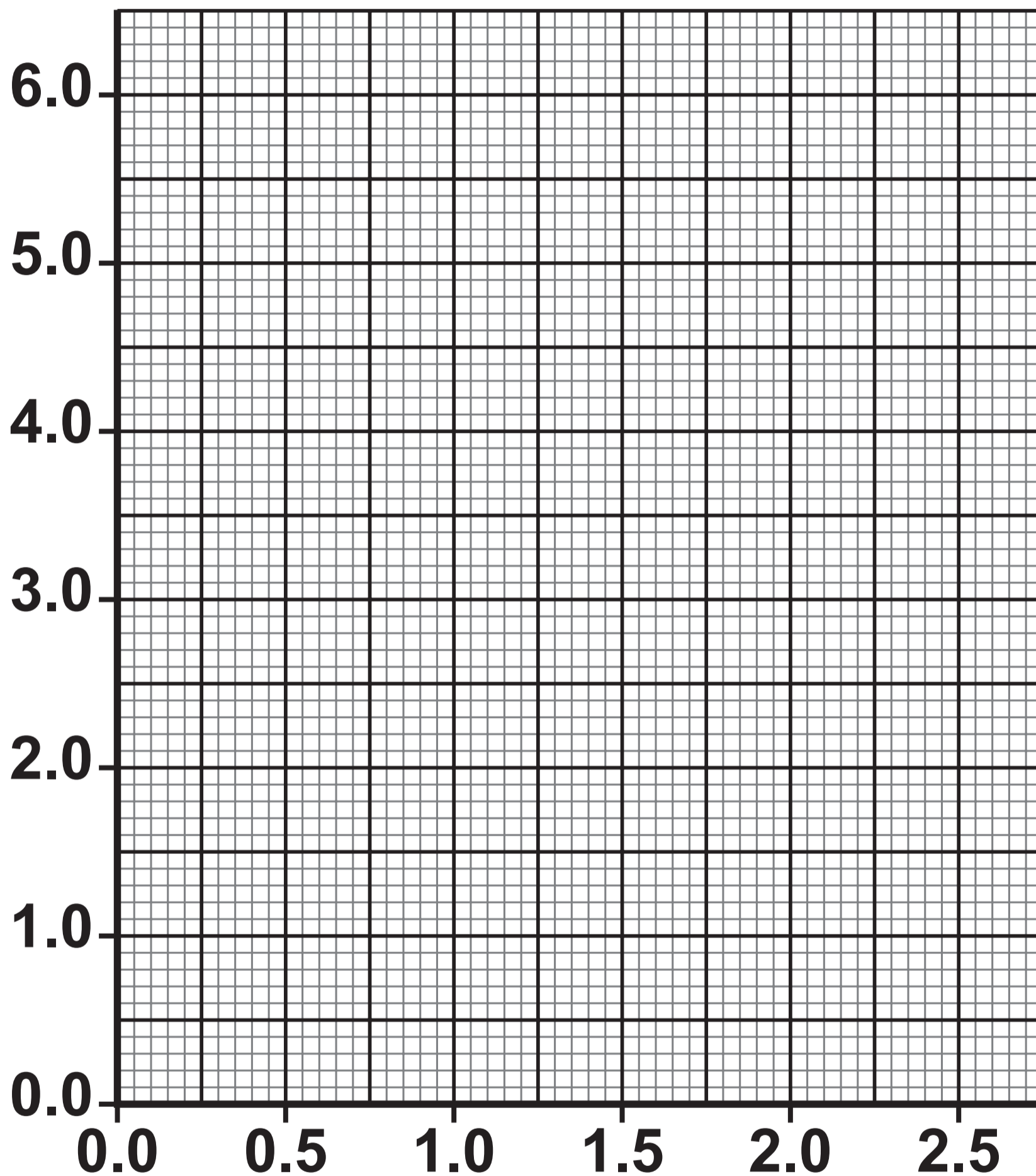
You should:

- **label the *x*-axis**
- **plot the data from TABLE 2, on page 59.**
- **draw a line of best fit. [4 marks]**



FIGURE 10

**Mass of lithium oxide
produced in grams**



[Turn over]





0 6 . 7

The teacher did the experiment four times using 0.25 g of lithium.

TABLE 3 shows the results.

TABLE 3

MASS OF LITHIUM REACTED IN GRAMS	MASS OF LITHIUM OXIDE PRODUCED IN GRAMS			
	TEST 1	TEST 2	TEST 3	TEST 4 MEAN
0.25	0.52	0.53	0.49	0.50
				X



**Calculate mean value X in TABLE 3, on the opposite page.
[2 marks]**

63

$X =$ **g**

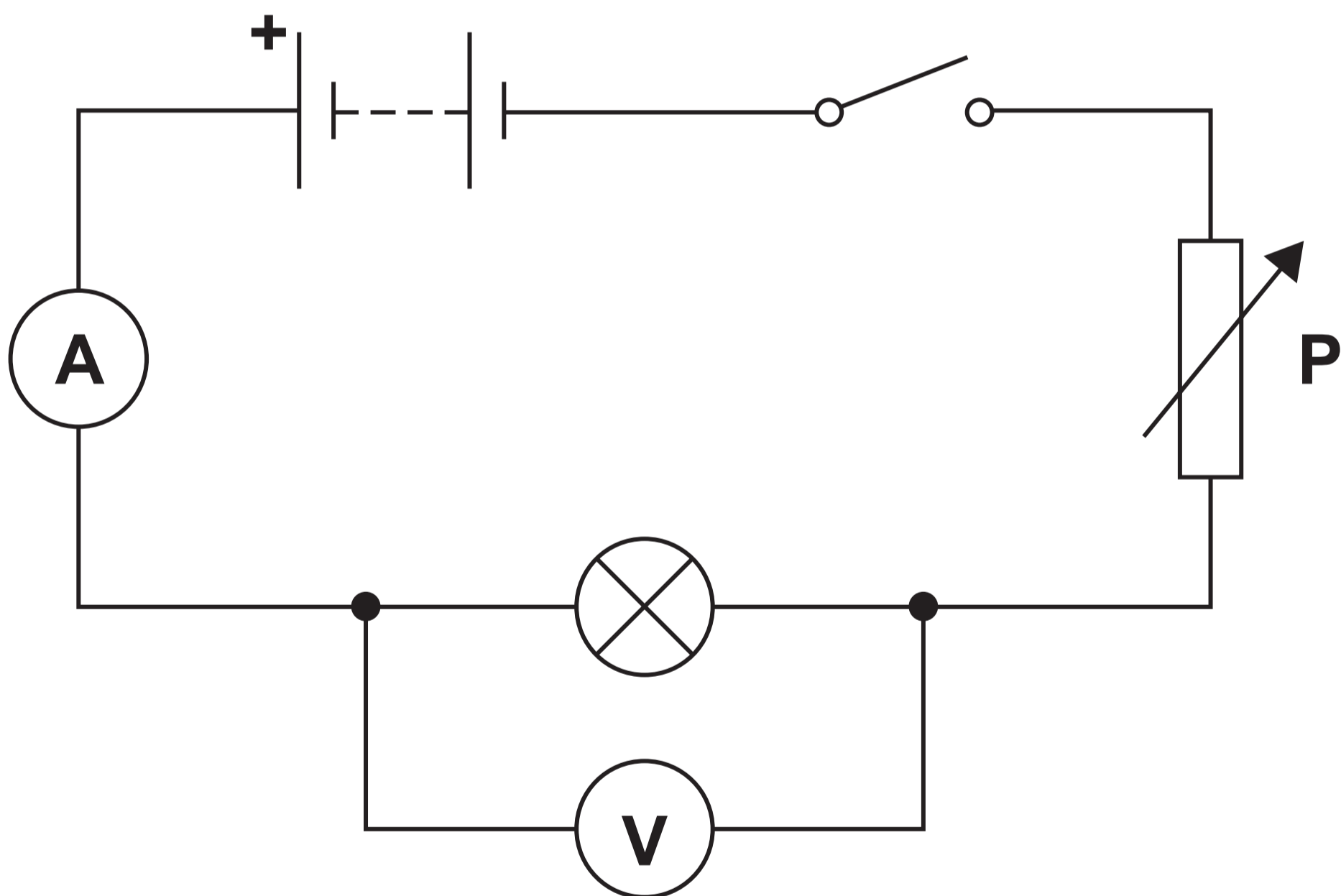
[Turn over]

07

A student investigated how the current in a filament lamp varies with the potential difference across the filament lamp.

FIGURE 11 shows the circuit used.

FIGURE 11



0	7	.	1
---	---	---	---

What is component P? [1 mark]

Tick (✓) ONE box.

A battery

A variable resistor

An open switch

[Turn over]



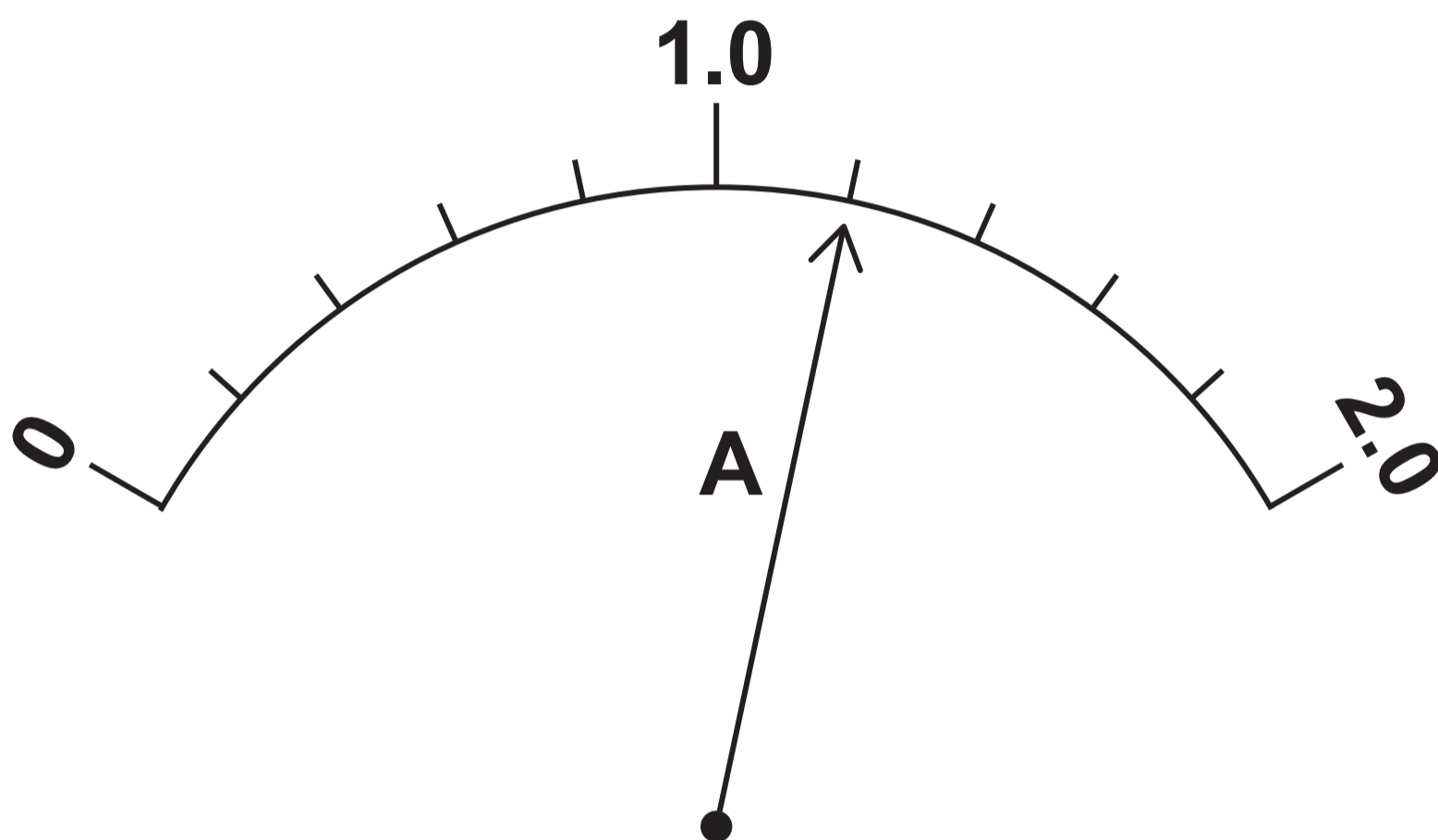
[Turn over]



0	7	.	3
---	---	---	---

FIGURE 12 shows the reading on the ammeter at one point in the investigation.

FIGURE 12



What is the reading on the ammeter?
[1 mark]

Ammeter reading = _____ A



BLANK PAGE

[Turn over]



07.4

The student repeated the investigation for two other components.

The student plotted a graph of current against potential difference for each component.

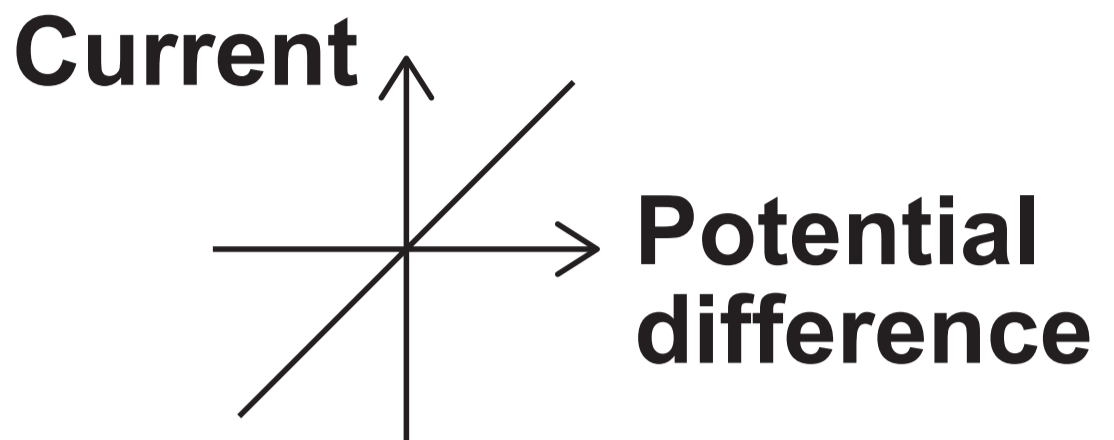
**Draw ONE line from each component to the correct graph, on the opposite page.
[3 marks]**



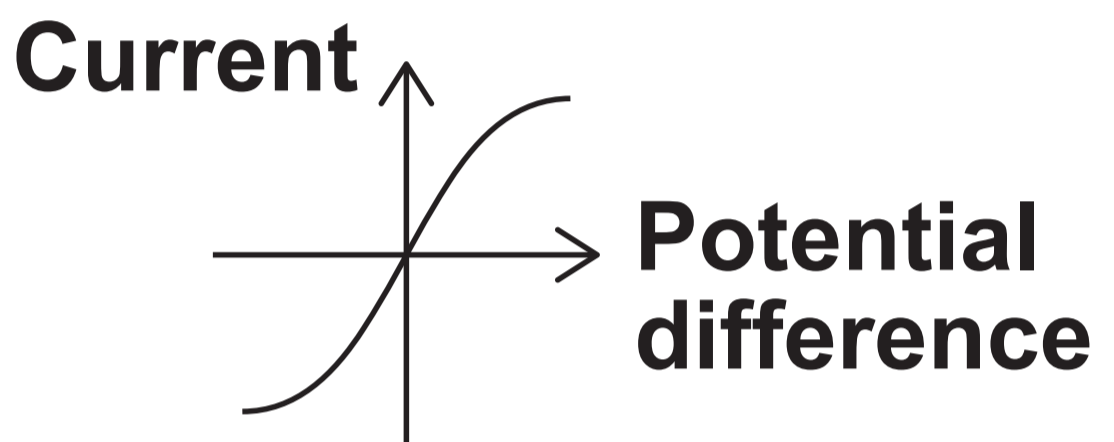
COMPONENT

GRAPH

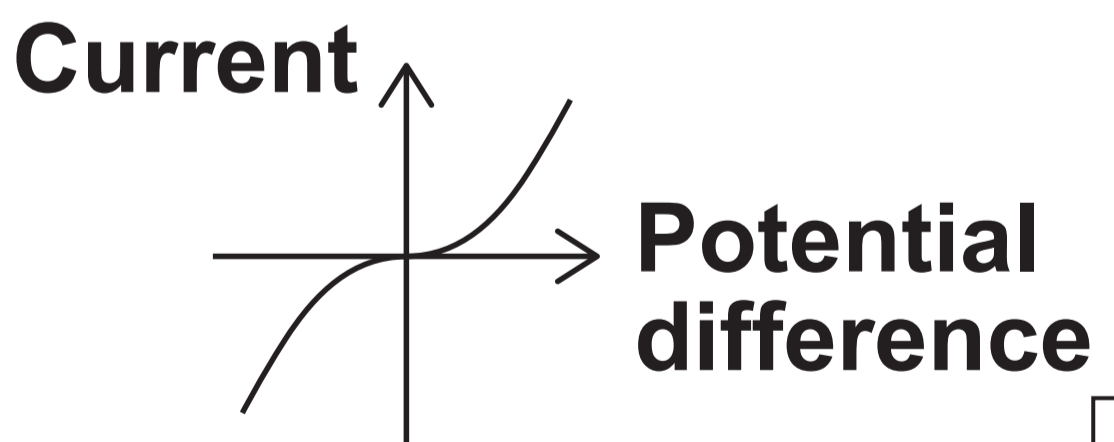
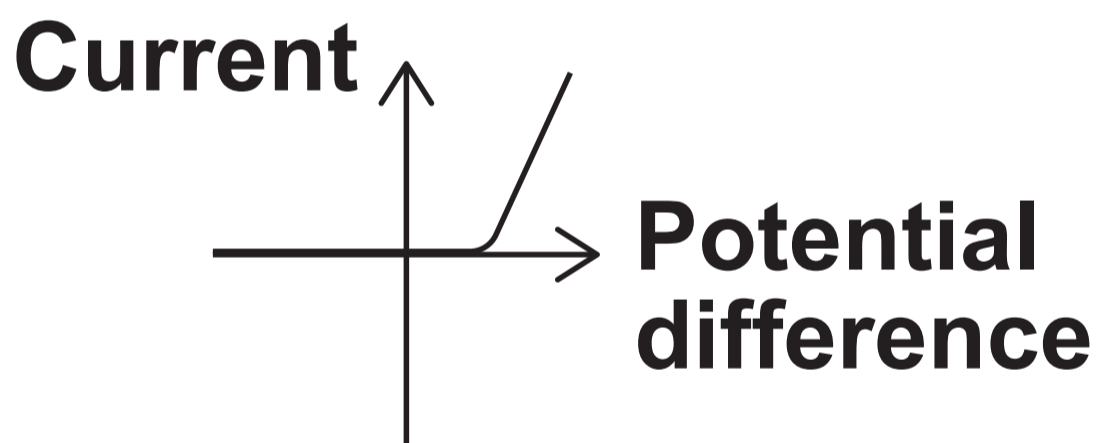
Diode



Filament lamp



**Resistor
(at constant temperature)**



[Turn over]



0	8
---	---

Enzymes are large molecules and biological catalysts.

0	8	.	1
---	---	---	---

**What type of molecule is an enzyme?
[1 mark]**



0	8	.	2
---	---	---	---

A catalyst changes the rate of a chemical reaction.

What happens to the mass of a catalyst during a chemical reaction? [1 mark]

Tick (✓) ONE box.

The mass of the catalyst decreases.

The mass of the catalyst stays the same.

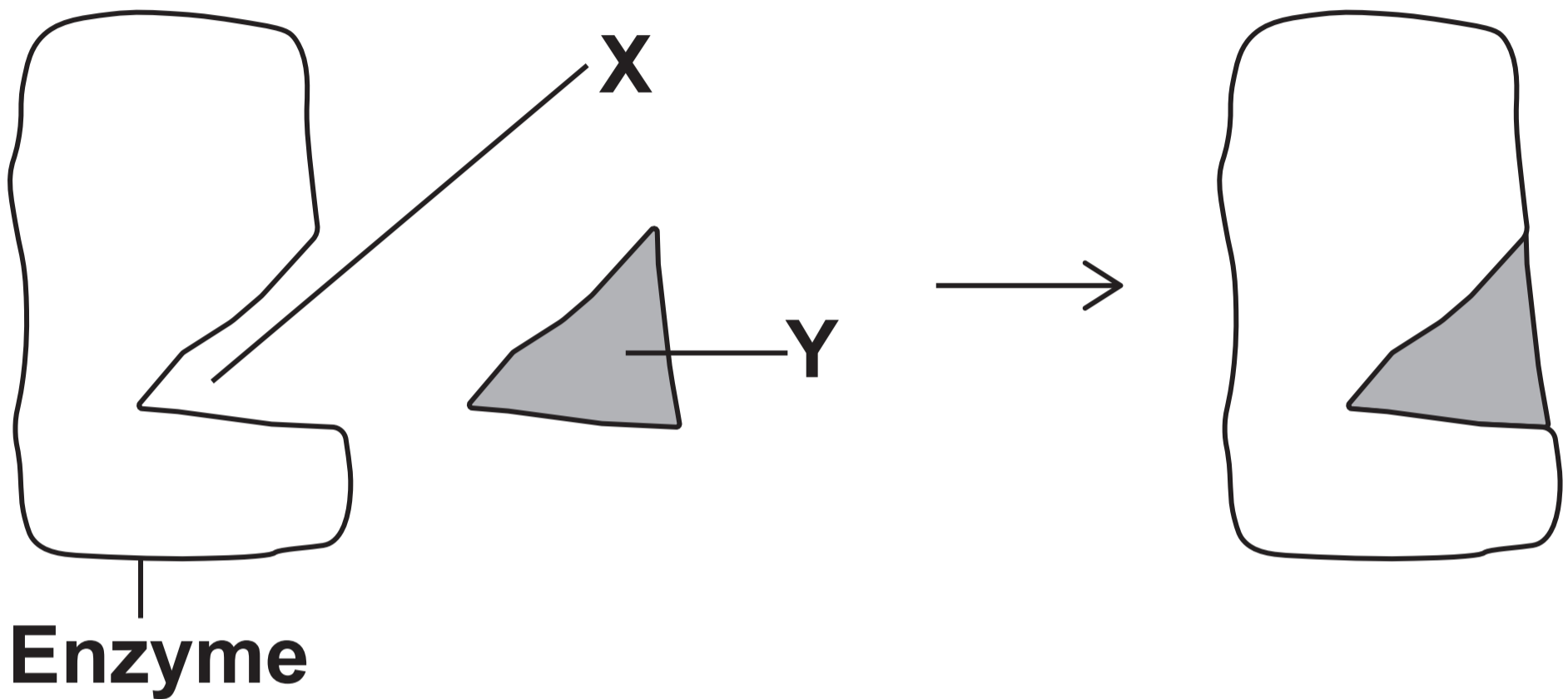
The mass of the catalyst increases.

[Turn over]



FIGURE 13 shows a model of enzyme action.

FIGURE 13



0 8 . 3

Name X and Y in FIGURE 13. [2 marks]

X _____

Y _____



0	8	.	4
---	---	---	---

Name the model shown in FIGURE 13, on the opposite page. [1 mark]

[Turn over]



Amylase is an enzyme that breaks down starch.

A student investigated how changing the pH affected the activity of amylase.

This is the method used.

- 1. Heat a test tube containing 2 cm³ of amylase solution at pH 5.0 in a water bath at 35 °C.**
- 2. Heat a test tube containing 2 cm³ of starch solution in the same water bath.**
- 3. Transfer the amylase solution into the test tube of starch solution and mix.**
- 4. After 30 seconds remove a drop of the amylase–starch mixture and test the drop for starch.**
- 5. Repeat step 4 until no starch is detected.**



6. Record the total time taken for no starch to be detected.
7. Repeat steps 1 to 6 using amylase solution at different pH values.

0 8 . 5

Explain why the solutions are all placed in the same water bath. [2 marks]

[Turn over]



0	8	.	6
---	---	---	---

Describe the test for starch.

Give the result of the test if starch is present. [2 marks]

Test _____

Result _____



TABLE 4 shows the results.

TABLE 4

pH	TIME TAKEN FOR NO STARCH TO BE DETECTED IN SECONDS
5.0	120
5.5	120
6.0	90
6.5	90
7.0	60
7.5	60
8.0	90
8.5	120

[Turn over]



0	8	.	7
---	---	---	---

Which range of pH values had the fastest rate of reaction? [1 mark]

Tick (✓) ONE box.

pH 5.0 to pH 5.5

pH 6.0 to pH 6.5

pH 7.0 to pH 7.5

pH 8.0 to pH 8.5



0	8	.	8
---	---	---	---

How could the method be improved to obtain a more accurate pH value for the fastest rate of reaction? [1 mark]

11

[Turn over]

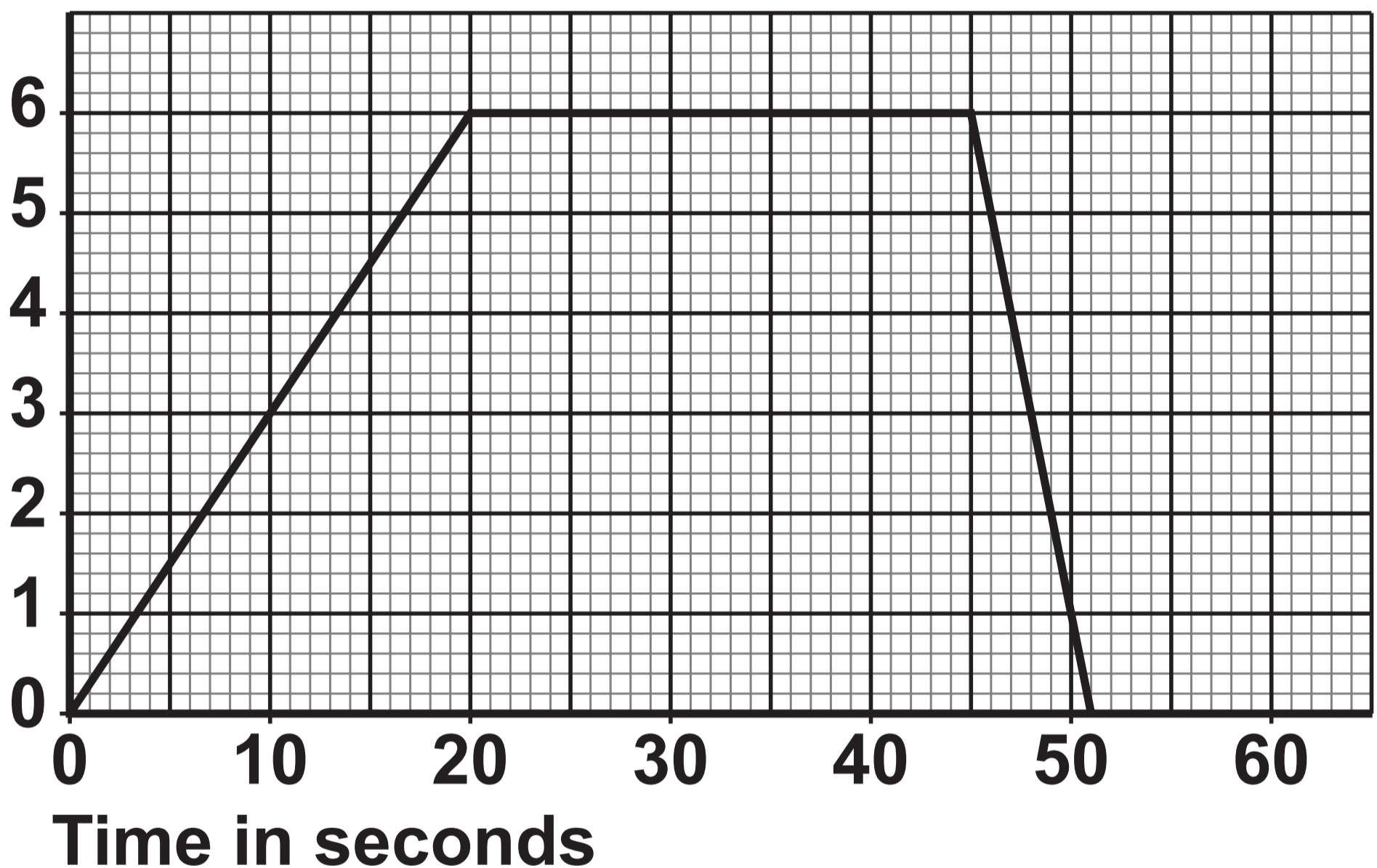


09

FIGURE 14 shows a velocity–time graph for a remote-controlled car.

FIGURE 14

Velocity in m/s



0	9	.	1
---	---	---	---

Determine the acceleration of the car between 0 and 20 seconds.

**Use the Physics Equations Sheet.
[2 marks]**

Acceleration = _____ m/s²

[Turn over]



0 9 . 2

Determine the distance travelled by the car between 20 seconds and 45 seconds.

**Use the Physics Equations Sheet.
[2 marks]**

Distance = _____ m



BLANK PAGE

[Turn over]



0	9	.	3
---	---	---	---

How does the deceleration of the car compare with the acceleration of the car?

Use FIGURE 14, repeated on the opposite page.

**Give ONE reason for your answer.
[2 marks]**

Tick (✓) ONE box.

The deceleration was greater than the acceleration.

The deceleration was the same as the acceleration.

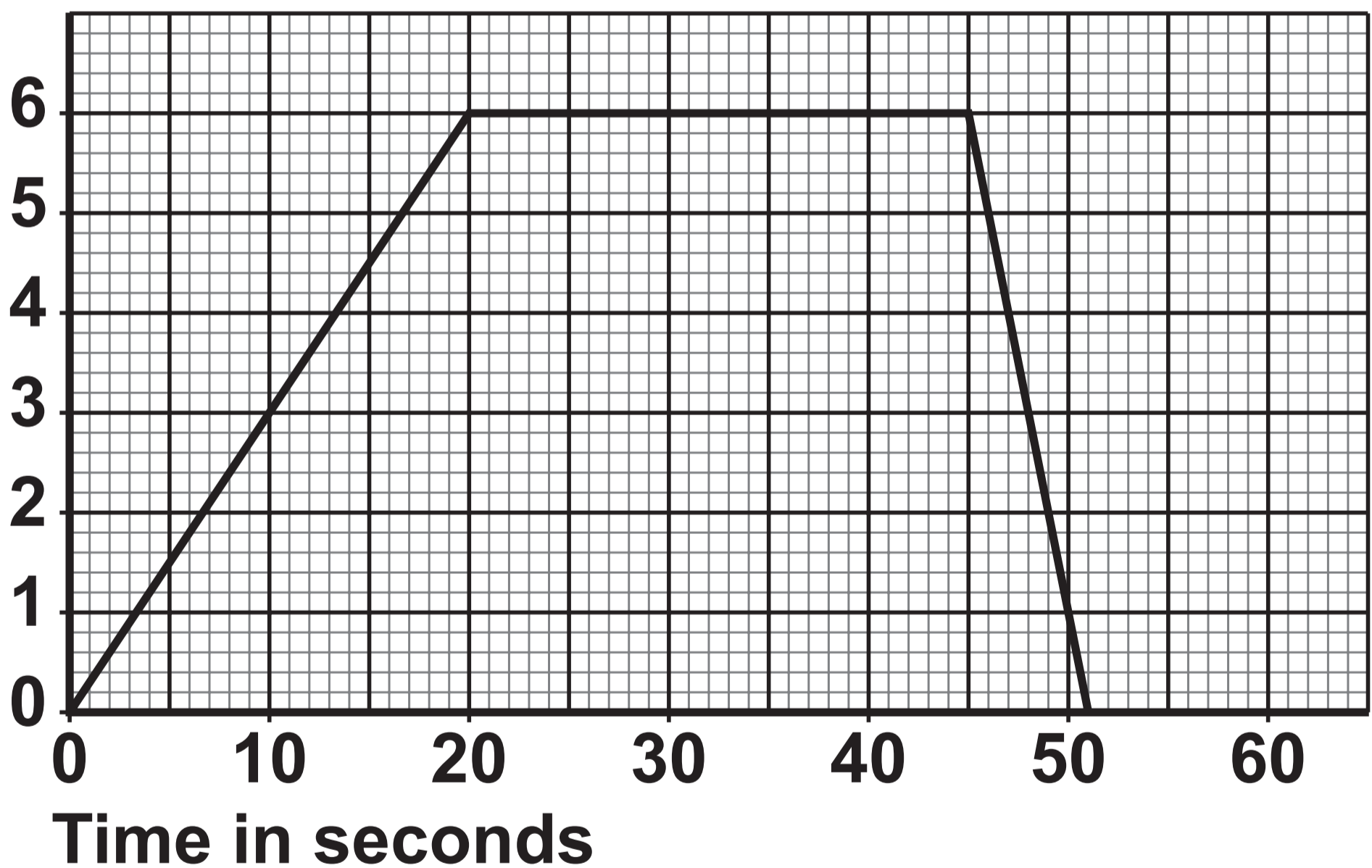
The deceleration was less than the acceleration.

Reason _____



FIGURE 14 is repeated here.

Velocity in m/s



[Turn over]



09.4

Another remote-controlled car travelled a distance of 80 m while accelerating from 0 m/s to 16 m/s.

Calculate the acceleration of this car.

Use the Physics Equations Sheet.

[3 marks]



Acceleration = _____ m/s²

9

[Turn over]



1	0
---	---

A student investigated the reaction between citric acid powder and sodium hydrogen carbonate solution.

The temperature of the reaction mixture decreased.

1	0	.	1
---	---	---	---

Plan a method to investigate how changing the mass of citric acid affects the lowest temperature reached by the mixture. [6 marks]





BLANK PAGE

[Turn over]

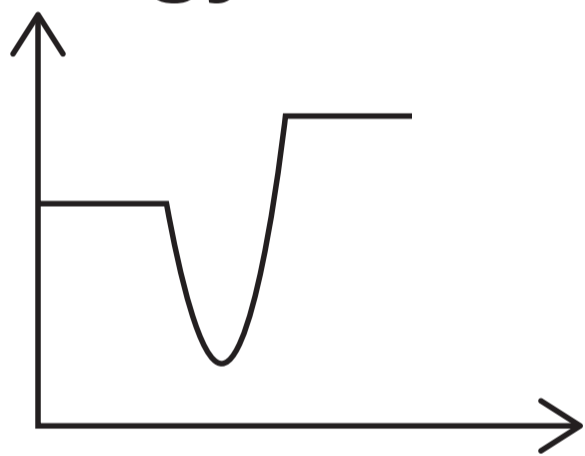
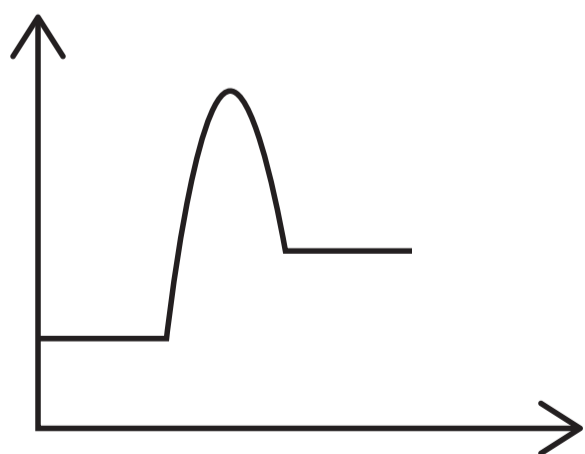


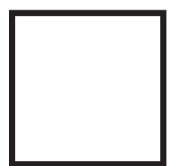
1 0 . 2

The reaction between citric acid and sodium hydrogen carbonate is endothermic.

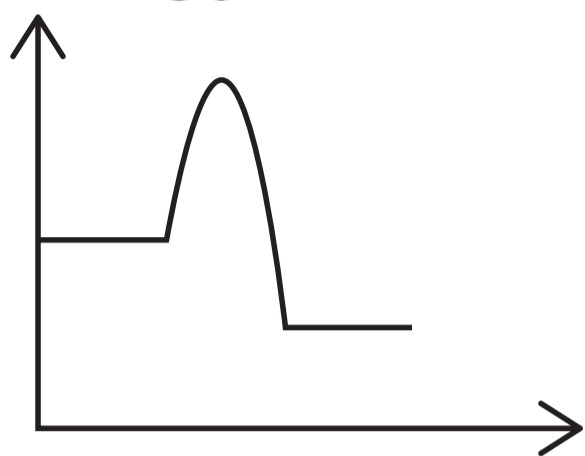
Which reaction profile represents an endothermic reaction? [1 mark]

Tick (✓) ONE box.

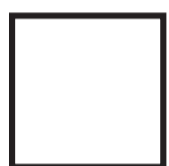
Energy**Progress of reaction****Energy****Progress of reaction**



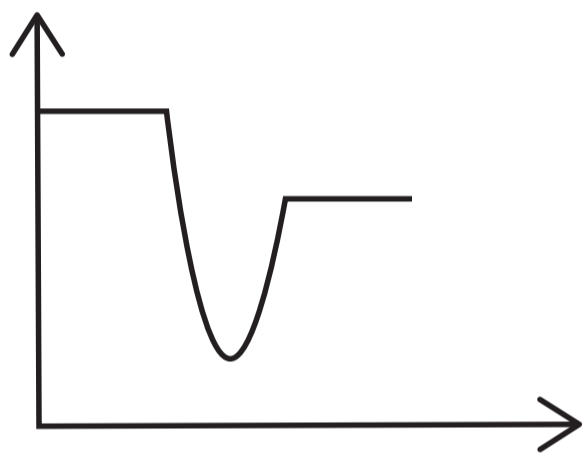
Energy



Progress of reaction



Energy



Progress of reaction

[Turn over]



1	0	.	3
---	---	---	---

Explain why the rate of reaction is greater when powder is used instead of larger lumps.

Refer to surface area and collisions in your answer. [2 marks]

9

END OF QUESTIONS



BLANK PAGE

For Examiner's Use	
Question	Mark
1	
2	
3	
4	
5	
6	
7	
8	
9	
10	
TOTAL	

Copyright information

For confidentiality purposes, all acknowledgements of third-party copyright material are published in a separate booklet. This booklet is published after each live examination series and is available for free download from www.aqa.org.uk.

Permission to reproduce all copyright material has been applied for. In some cases, efforts to contact copyright-holders may have been unsuccessful and AQA will be happy to rectify any omissions of acknowledgements. If you have any queries please contact the Copyright Team.

Copyright © 2024 AQA and its licensors. All rights reserved.

G/LM/Jun24/8465/3F/G4001/E3

