

A



**Surname** \_\_\_\_\_

**Other Names** \_\_\_\_\_

**Centre Number** \_\_\_\_\_

**Candidate Number** \_\_\_\_\_

**Candidate Signature** \_\_\_\_\_

**A-level**

**PHYSICS**

**Paper 1**

**7408/1**

**Monday 20 May 2019**

**Afternoon**

**Time allowed: 2 hours**

**For this paper you must have:**

- a pencil and a ruler
- a scientific calculator
- a Data and Formulae Booklet.

**At the top of the page, write your surname and other names, your centre number, your candidate number and add your signature.**

**[Turn over]**



J U N 1 9 7 4 0 8 1 0 1

**BLANK PAGE**



## INSTRUCTIONS

- Use black ink or black ball-point pen.
- Answer ALL questions.
- You must answer the questions in the spaces provided. Do not write on blank pages.
- If you need extra space for your answer(s), use the lined pages at the end of this book. Write the question number against your answer(s).
- Do all rough work in this book. Cross through any work you do not want to be marked.
- Show all your working.

## INFORMATION

- The marks for questions are shown in brackets.
- The maximum mark for this paper is 85.
- You are expected to use a scientific calculator where appropriate.
- A Data and Formulae Booklet is provided as a loose insert.

**DO NOT TURN OVER UNTIL TOLD TO DO SO**



## SECTION A

Answer ALL questions in this section.

**01.1** Two isotopes of iodine are  ${}^{125}_{53}\text{I}$  and  ${}^{131}_{53}\text{I}$ .

Determine, for these two isotopes, the difference between the constituents of the nuclei. [1 mark]

---

---

---

**01.2** A  ${}^{131}_{53}\text{I}$  nuclide undergoes beta ( $\beta^-$ ) decay to form a xenon nuclide.

State the nucleon number of the xenon nuclide. [1 mark]

---

---



**01.3** A  $^{125}_{53}\text{I}$  nuclide decays by electron capture to form a tellurium nuclide.

**State TWO differences between the constituents of the iodine nucleus and the tellurium nucleus it decays into. [2 marks]**

---

---

---

---

---

---

---

**[Turn over]**



**01.4** Internal conversion is a process in which a nucleus in an excited state can release its excess energy. In internal conversion all of the excess energy is transferred from the nucleus to an orbital electron through the electromagnetic force. This orbital electron is ejected from the atom.

The tellurium nucleus formed in question 01.3 is in an excited state and can undergo internal conversion.

Discuss **THREE** differences between internal conversion and beta ( $\beta^-$ ) decay. [3 marks]

1

---

---

---

---

---

2

---

---

---



---

---

3

---

---

---

---

---

---

---

[Turn over]

7



- 0 2** Some cars are fitted with a water sensor designed to switch on windscreen wipers automatically when it rains. **FIGURE 1** shows a simplified diagram of the sensor.

**FIGURE 1**

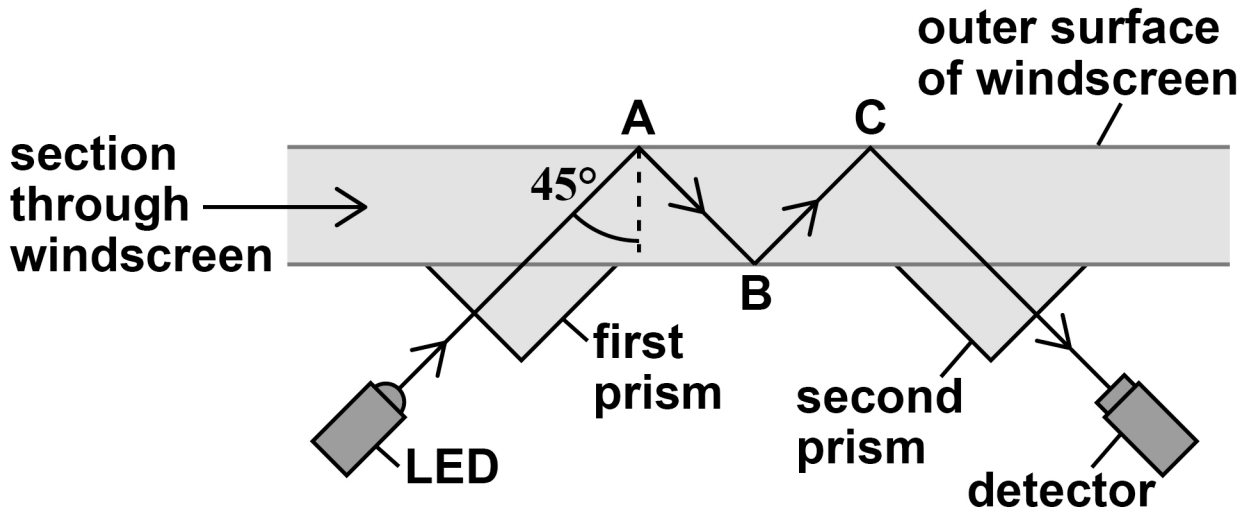

A light ray travels from the light-emitting diode (LED) through the first prism and into the windscreen. The ray reflects off the surfaces of the windscreen at A, B and C and then passes through the second prism into the detector.



**0 2 . 1** Suggest how the design ensures that there is no deviation of the ray as it enters the first prism. [1 mark]

---

---

---

**0 2 . 2** Suggest TWO features of the design that ensure that there is no deviation of the ray as it leaves the first prism and enters the windscreen glass. [2 marks]

1

---

---

---

2

---

---

---

**[Turn over]**



**BLANK PAGE**



**0 2 . 3** The refractive index of the windscreen glass is 1.52

**Explain why the ray follows the path shown inside the windscreen glass in FIGURE 1, on page 8.**

**Support your answer with a suitable calculation. [2 marks]**

---

---

---

---

---

---

---

---

**[Turn over]**



- 02.4** When it starts to rain, water droplets form on the outside of the windscreen as shown in **FIGURE 2**.

**FIGURE 2**

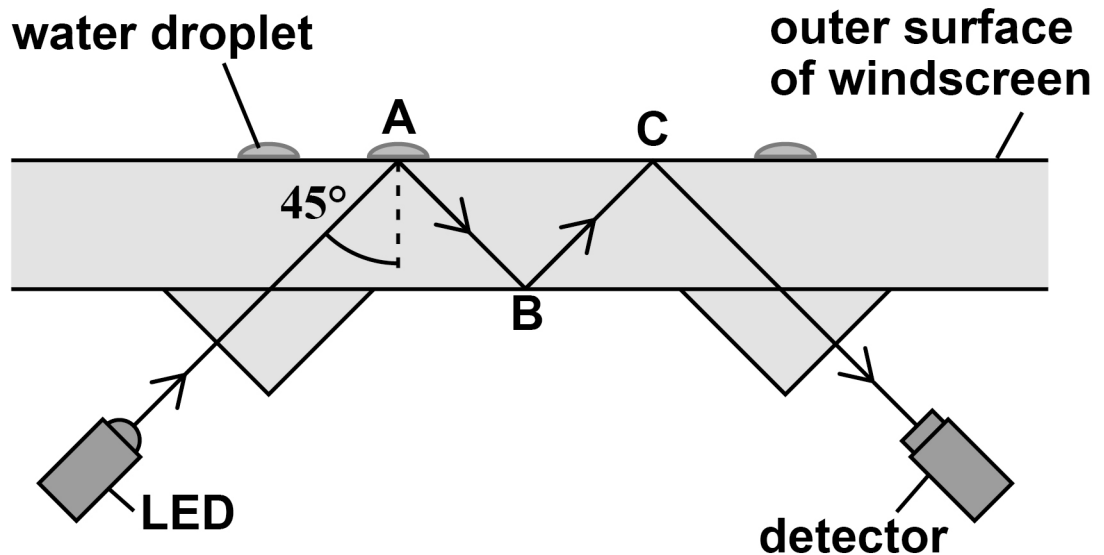

The refractive index of water is 1.33

Explain why the presence of water at A causes the intensity of the light at the detector to decrease.

Support your answer with a suitable calculation. [2 marks]



---

---

---

---

---

---

---

---

---

---

---

**[Turn over]**





02.6

A different design has the LED and the detector further apart. The ray undergoes more reflections inside the windscreen glass before reaching the detector.

Discuss TWO ways in which this different design affects the sensitivity of the sensor to the presence of water droplets. [2 marks]

1 \_\_\_\_\_  
\_\_\_\_\_  
\_\_\_\_\_  
\_\_\_\_\_  
\_\_\_\_\_

2 \_\_\_\_\_  
\_\_\_\_\_  
\_\_\_\_\_  
\_\_\_\_\_

[Turn over]

11



**03**

**FIGURE 3** shows an arrangement to investigate diffraction. White light is incident on a single slit. After leaving the slit, the diffracted light passes through a green filter to reach the screen.

**FIGURE 3**

The diagram is NOT drawn to scale.

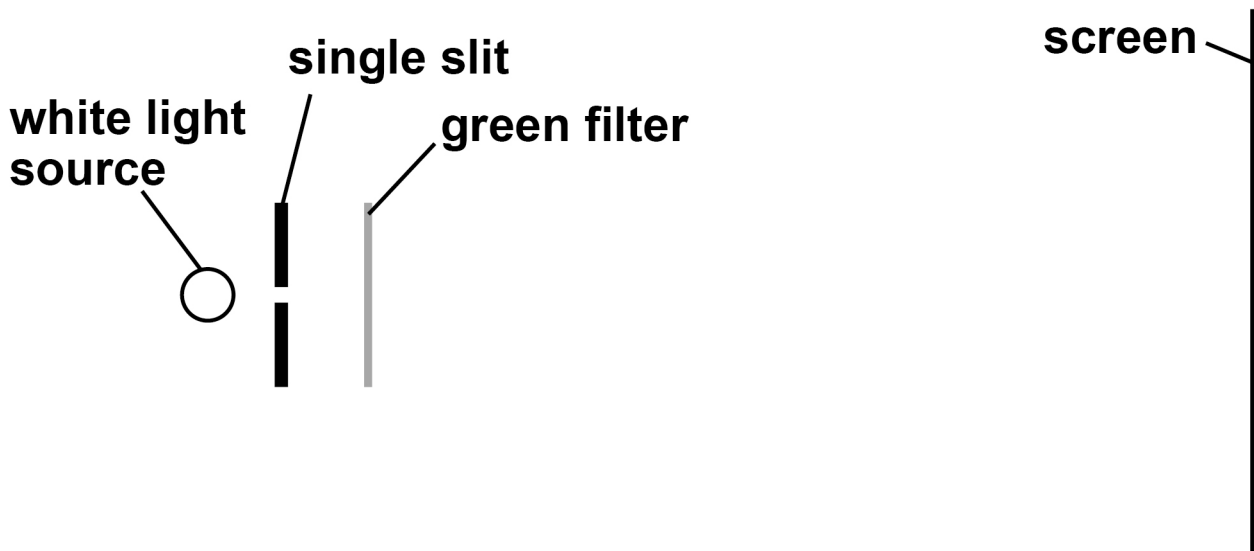
**03.1**

**Describe the pattern produced on the screen.**  
**[2 marks]**

---

---

---

---



---

---

---

---

---

---

**03.2** The green filter is replaced with a red filter.

**Describe the change in the pattern produced on the screen. [2 marks]**

---

---

---

---

---

---

---

**[Turn over]**



- 03.3** A diffraction grating is placed between the red filter and the screen. The diffraction grating has 500 lines per millimetre. Light is incident normally on the grating. FIGURE 4 shows the arrangement.

**FIGURE 4**

The diagram is NOT drawn to scale.

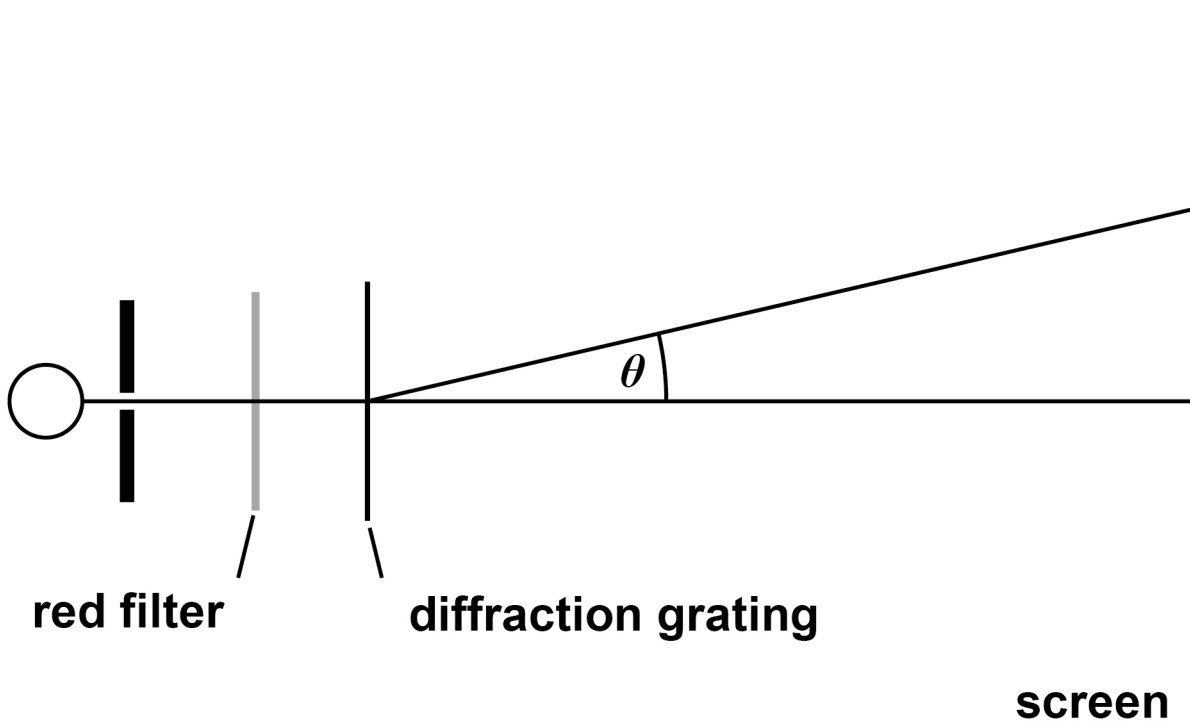

The wavelength of the red light is 650 nm.



Calculate the angle  $\theta$  between a first-order maximum and the central maximum.

[2 marks]

$\theta =$  \_\_\_\_\_ degrees

[Turn over]



**03.4** In practice, the filter transmits red light with wavelengths in the range 600 nm to 700 nm.

**Suggest how this affects the appearance of the maxima. [2 marks]**

---

---

---

---



---

---

---

---

---

---

---

[Turn over]

8



- 0 4** FIGURE 5 shows a simplified catapult used to hurl projectiles a long way.

**FIGURE 5**

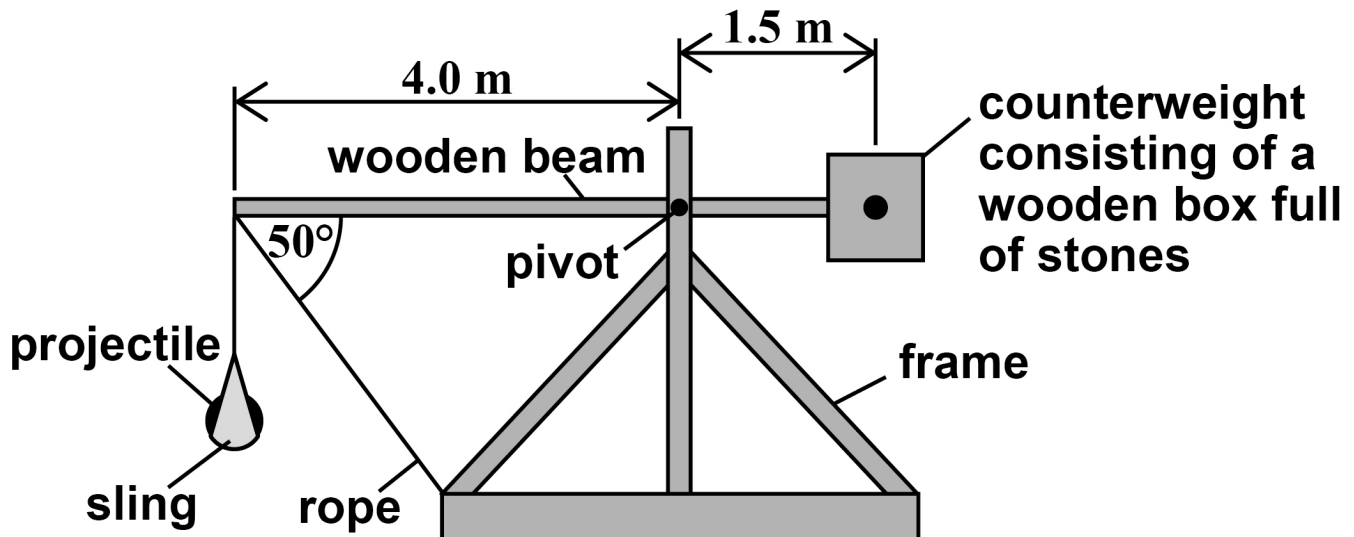

The counterweight is a wooden box full of stones attached to one end of the beam. The projectile, usually a large rock, is in a sling hanging vertically from the other end of the beam. The weight of the sling is negligible. The beam is held horizontal by a rope attached to the frame.

- 0 4 . 1** The catapult is designed so that the weight of the beam and the weight of the **EMPTY** wooden box have no effect on the tension in the rope.

Suggest how the pivot position achieves this.  
[2 marks]





**BLANK PAGE**



**04.2** The stones in the counterweight have a total mass of 610 kg and the projectile weighs 250 N.

**Calculate the tension in the rope. [5 marks]**

tension = \_\_\_\_\_ N

**[Turn over]**



- 04.3** When the rope is cut, the counterweight rotates clockwise. When the beam is vertical it is prevented from rotating further. The projectile is then released horizontally with a velocity of  $18 \text{ m s}^{-1}$ , as shown in FIGURE 6.

The projectile is released at a height of  $7.5 \text{ m}$  above ground level.

**FIGURE 6**

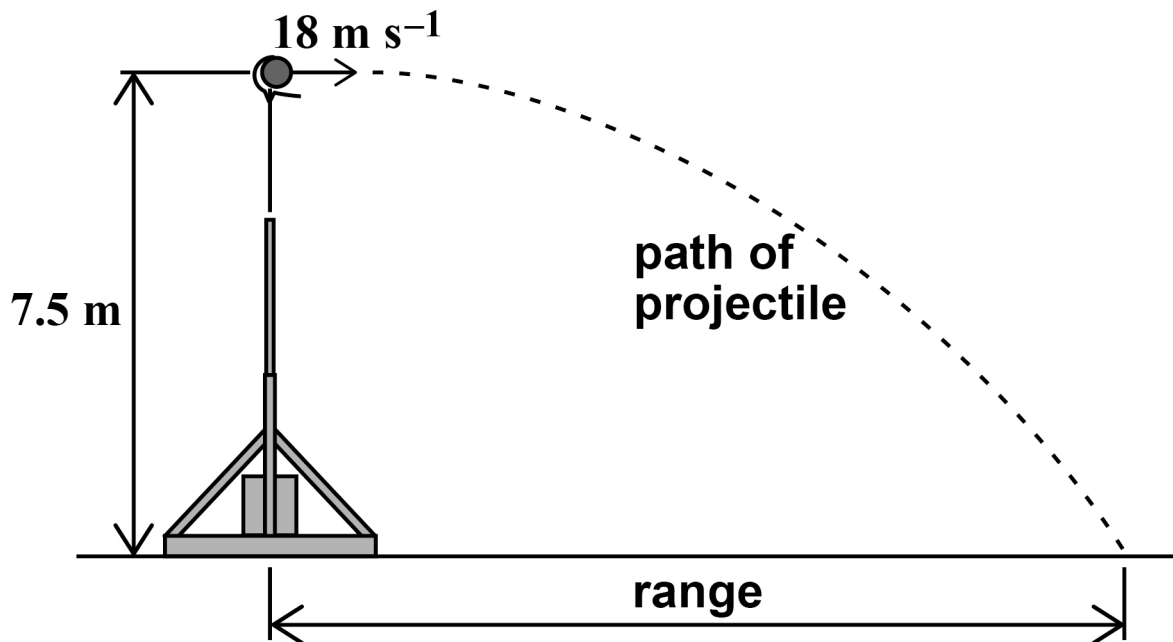

The range of the catapult is the horizontal distance between the point where the projectile is released to the point where it lands.

Calculate the range.  
Ignore air resistance. [2 marks]

range = \_\_\_\_\_ m

[Turn over]



**BLANK PAGE**





**0 5**

Safety barriers are used on UK motorways to prevent vehicles crossing from one carriageway to the other carriageway. The barriers also absorb some of the kinetic energy of a vehicle and deflect vehicles along the barrier.

The standard test of a safety barrier uses a vehicle that contains dummies. The total mass of the vehicle and its contents is  $1.5 \times 10^3$  kg and its initial speed is  $110 \text{ km h}^{-1}$ .

**0 5 . 1**

Show that the initial kinetic energy of the test vehicle is 700 kJ. [2 marks]



- 05.2** The test vehicle hits a steel safety barrier at an angle of  $20^\circ$ , as shown in FIGURE 7.

**FIGURE 7**

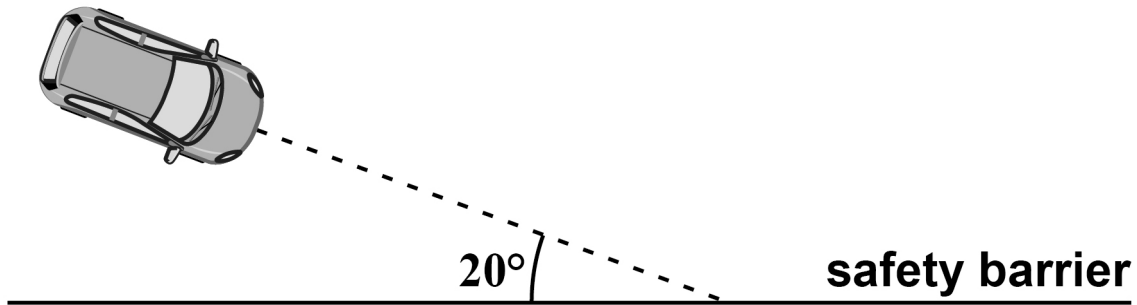

Calculate the component of the momentum of the test vehicle in a direction along the line of the safety barrier. Give an appropriate unit for your answer.  
[3 marks]

momentum = \_\_\_\_\_ unit \_\_\_\_\_

[Turn over]



- 05. 3** Immediately after the collision, the test vehicle moves along the safety barrier with no change in its momentum in this direction.

**Show that the kinetic energy lost in the collision is about 80 kJ. [3 marks]**



- 05.4** The steel safety barrier deforms during the collision. For the barrier to pass the test, the test vehicle should not move more than 1.5 m towards the other carriageway.

The barrier can apply an average force of 60 kN at right angles to the carriageway.

Deduce whether the safety barrier will pass the test. [3 marks]

---

---

---

**[Turn over]**



BLANK PAGE





06

A loudspeaker cone is driven by a signal generator (oscillator).

FIGURE 8 shows the variation of displacement with time  $t$  for a point P at the centre of the cone. P is oscillating with simple harmonic motion.

FIGURE 8

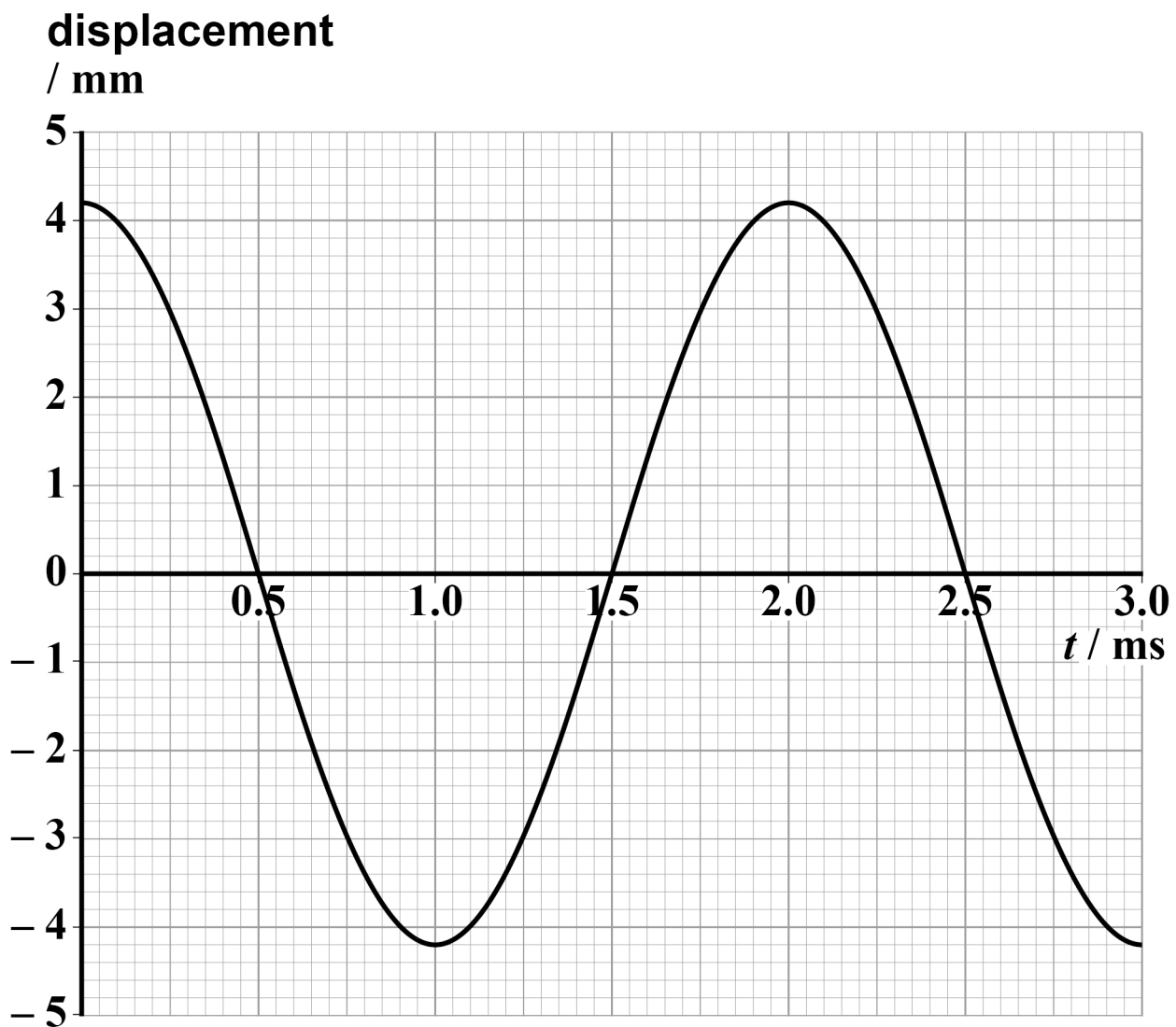

- 06.1** State the time, in milliseconds, when P is moving at its maximum positive velocity.  
[1 mark]

time = \_\_\_\_\_ ms

- 06.2** Calculate the maximum acceleration of P.  
[3 marks]

acceleration = \_\_\_\_\_  $\text{m s}^{-2}$

[Turn over]



**06.3** The loudspeaker creates variations in pressure and produces a sound wave in the air around it.

**State the type of wave produced and describe the motion of the particles in this type of wave. [1 mark]**

---

---

---

---

---

---

---

<b>5</b>



**BLANK PAGE**

**[Turn over]**



07

FIGURE 9 shows a practical circuit in which a variable resistor is used to control the brightness of a lamp. The voltmeter reading is monitored as the variable resistor is adjusted to make the lamp brighter.

FIGURE 9

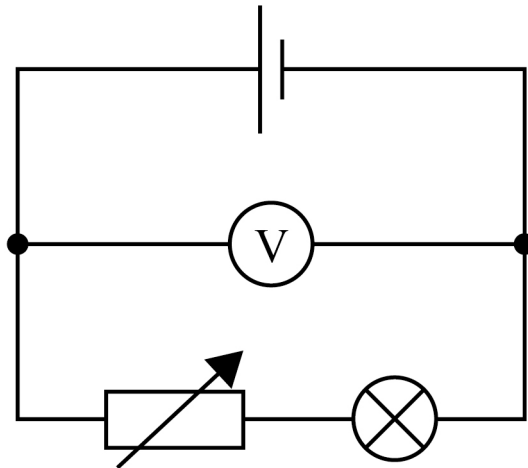

**07.1** Explain why the reading on the voltmeter decreases as the brightness of the lamp increases. [2 marks]

---

---

---

---

---

---

---

---

---

---

---

**[Turn over]**



- 07 . 2** The variable resistor is adjusted so that the lamp is at its brightest. The reading  $V_1$  on the voltmeter is noted. A second identical cell is then connected in parallel with the cell in FIGURE 9, on page 40. The new reading  $V_2$  on the voltmeter is noted.

**Explain why  $V_2$  is greater than  $V_1$ . [2 marks]**

---

---

---

---

---

---

---

---

---

---

4



**SECTION B**

Each of Questions 8 to 32 is followed by four responses, A, B, C and D.

For each question select the best response.

Only ONE answer per question is allowed.

For each question completely fill in the circle alongside the appropriate answer.

**CORRECT METHOD**

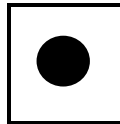

**WRONG METHODS**

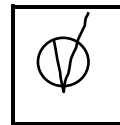
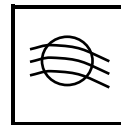
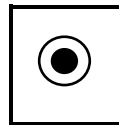
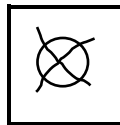

If you want to change your answer you must cross out your original answer as shown.

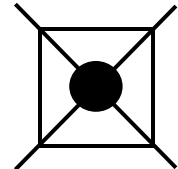

If you wish to return to an answer previously crossed out, ring the answer you now wish to select as shown.

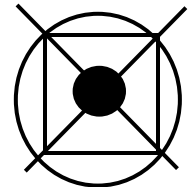

You may do your working in the blank space around each question but this will not be marked. Do NOT use additional sheets for this working.

[Turn over]



**08** The process of beta plus ( $\beta^+$ ) decay can be represented by

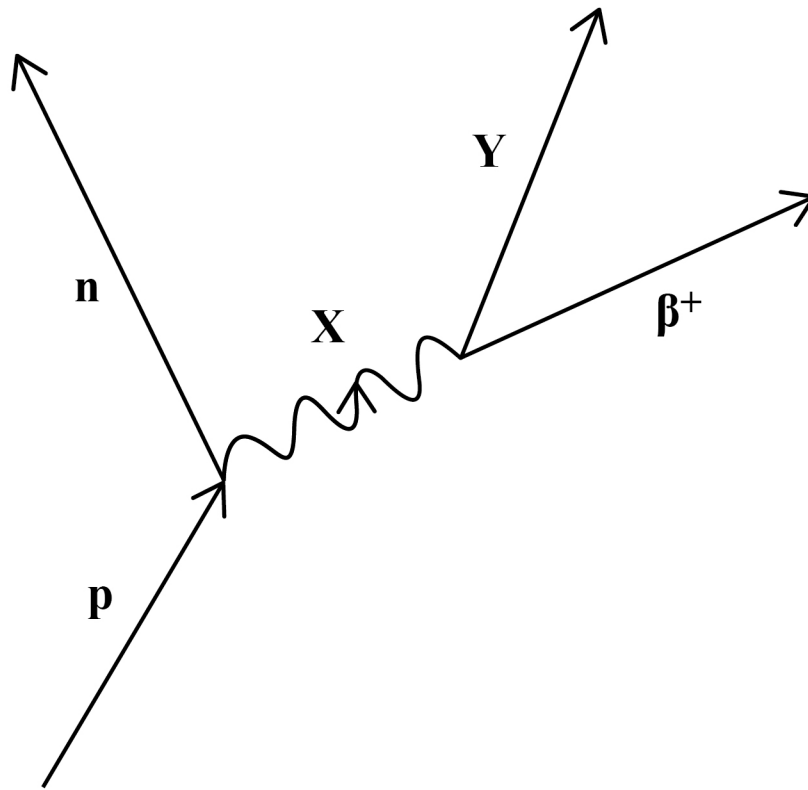

Which row identifies particles X and Y? [1 mark]

	X	Y
A	$W^+$	$\nu_e$
B	$W^+$	$\bar{\nu}_e$
C	$W^-$	$\nu_e$
D	$W^-$	$\bar{\nu}_e$

[Turn over]



**0 9**

An electron collides with an isolated atom and raises an orbiting electron to a higher energy level.

Which statement is correct? [1 mark]

**A** The colliding electron is captured by the nucleus of the atom.

**B** A photon is emitted when the electron rises to the higher energy level.

**C** An electron is emitted when the excited electron returns to the ground state.

**D** Energy is transferred from the colliding electron to the orbiting electron.



**1 0**

Light of frequency  $2.0 \times 10^{15}$  Hz is incident on a metal surface. The work function of the metal is  $4.6 \times 10^{-19}$  J.

Which statement is correct? [1 mark]

**A** No photoelectrons are released.

**B** Photoelectrons are released with a maximum kinetic energy of  $3.1 \times 10^{-19}$  J.

**C** Photoelectrons are released with a maximum kinetic energy of  $8.7 \times 10^{-19}$  J.

**D** Photoelectrons are released with a maximum kinetic energy of  $18 \times 10^{-19}$  J.

[Turn over]



1	1
---	---

A photon of ultraviolet radiation has a frequency of  $1.5 \times 10^{15}$  Hz.

What is the momentum of the photon?  
[1 mark]

A  $3.3 \times 10^{-41}$  kg m s<sup>-1</sup>

B  $1.3 \times 10^{-40}$  kg m s<sup>-1</sup>

C  $3.3 \times 10^{-27}$  kg m s<sup>-1</sup>

D  $1.3 \times 10^{-26}$  kg m s<sup>-1</sup>



**1 2** Which statement about a couple is NOT true?  
[1 mark]

**A** It must consist of coplanar forces.

**B** It can produce rotational motion.

**C** It can produce translational motion.

**D** It has a moment with units **N m**.

[Turn over]



- 1 3** Two cars P and Q leave from the same point and travel in the same direction.

Q leaves at time  $t = 0$  and P leaves one second later.

The figure shows the velocity–time graph for P and Q.

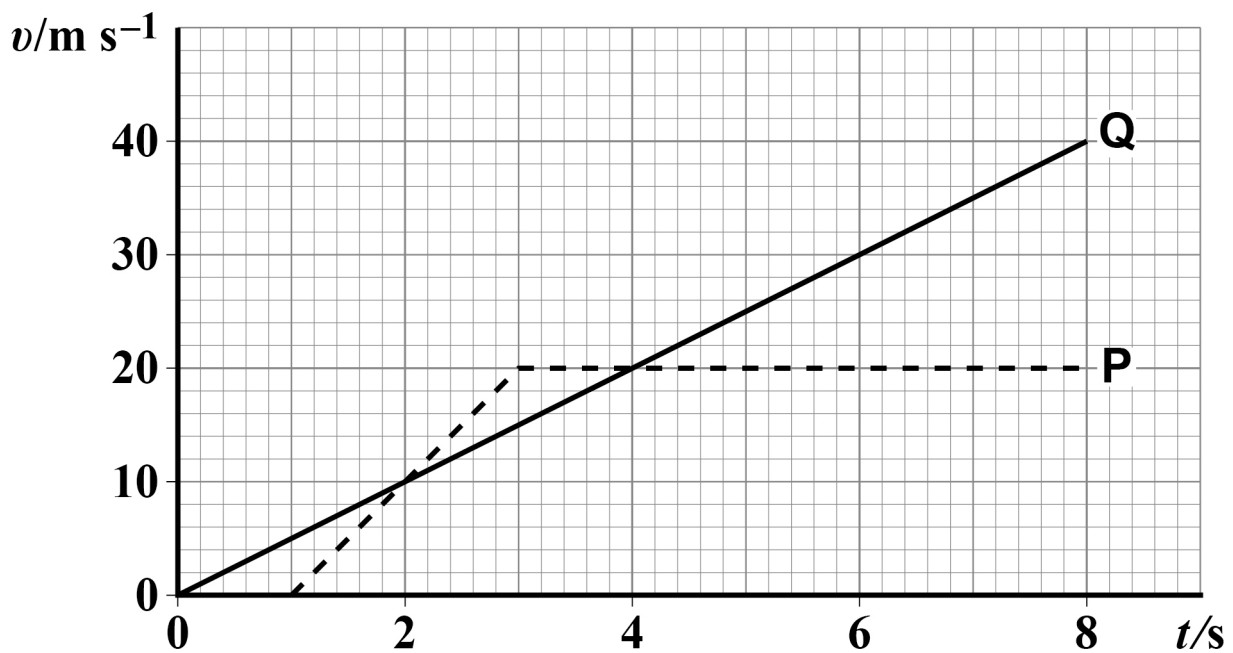

What is the distance between Q and P when  $t = 8 \text{ s}$ ? [1 mark]

A 40 m

B 80 m

C 160 m

D 180 m

[Turn over]



**1 4**

A 0.20 kg mass is suspended from a spring.  
A 0.10 kg mass is suspended from the 0.20 kg  
mass using a thread of negligible mass.

The system is in equilibrium and the thread is  
then cut.

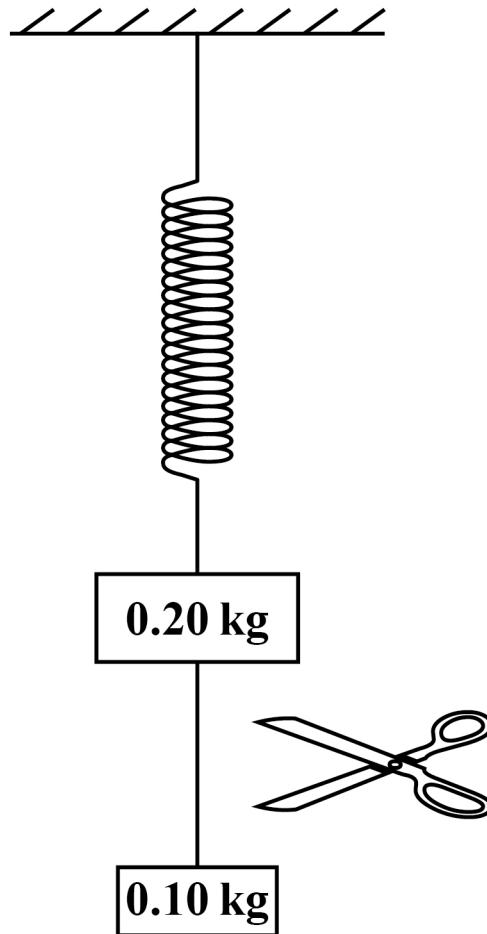

What is the upward acceleration of the 0.20 kg mass at the instant that the thread is cut?

[1 mark]

**A** 3.3 m s<sup>-2</sup>

**B** 4.9 m s<sup>-2</sup>

**C** 6.5 m s<sup>-2</sup>

**D** 9.8 m s<sup>-2</sup>

[Turn over]



1 5

A lift of mass  $M$  is suspended from a cable. The lift descends with a downward acceleration,  $a$ . A frictional force  $F$  acts on the lift.

What is the tension  $T$  in the cable? [1 mark]

**A**  $T = Ma + F$

**B**  $T = Ma - F$

**C**  $T = M(g + a) - F$

**D**  $T = M(g - a) - F$



**1 6** A body of constant mass falls freely due to gravity.

The rate of change of momentum of the body is equal to its [1 mark]

**A kinetic energy.**

**B mass.**

**C gravitational potential energy.**

**D weight.**

**[Turn over]**



**1 7**

An electric vehicle is driven by a motor which produces a constant driving force.

The vehicle travels from rest along a straight horizontal road.

Friction and air resistance are negligible.

Which statement describes the variation with time of the power developed by the motor?  
[1 mark]

**A It stays constant.**

**B It increases linearly from zero.**

**C It increases non-linearly from zero.**

**D It increases from zero to a maximum and then decreases.**



**1 8**

Which is a correct statement about mechanical power? [1 mark]

**A** It is a vector quantity.

**B** It is measured in J.

**C** In fundamental units, its unit is  $\text{kg m}^2 \text{s}^{-3}$

**D** It can be calculated from force  $\times$  distance moved.

[Turn over]



**1 9**

A load of 50 N is suspended from a wire that has an area of cross-section of 1 mm<sup>2</sup>.

The stress in the wire, in Pa, is between  
[1 mark]

**A** 10<sup>0</sup> and 10<sup>3</sup>

**B** 10<sup>3</sup> and 10<sup>6</sup>

**C** 10<sup>6</sup> and 10<sup>9</sup>

**D** 10<sup>9</sup> and 10<sup>12</sup>



- 20** Which combination of properties would produce the smallest extension of a wire when the same tensile force is applied to the wire?

	Cross-sectional area	Length	Young modulus of material	
<input type="radio"/>	<b>A</b>	$X$	$3L$	$E$
<input type="radio"/>	<b>B</b>	$2X$	$L$	$E$
<input type="radio"/>	<b>C</b>	$X$	$3L$	$4E$
<input type="radio"/>	<b>D</b>	$2X$	$L$	$4E$

[Turn over]



**2 1**

A rubber belt in an electrostatic machine has a width of 0.1 m and moves with speed  $0.4 \text{ m s}^{-1}$ .

Each square metre of the belt carries a charge  $Q$  coulomb. The charge is removed and transferred to a metal sphere.

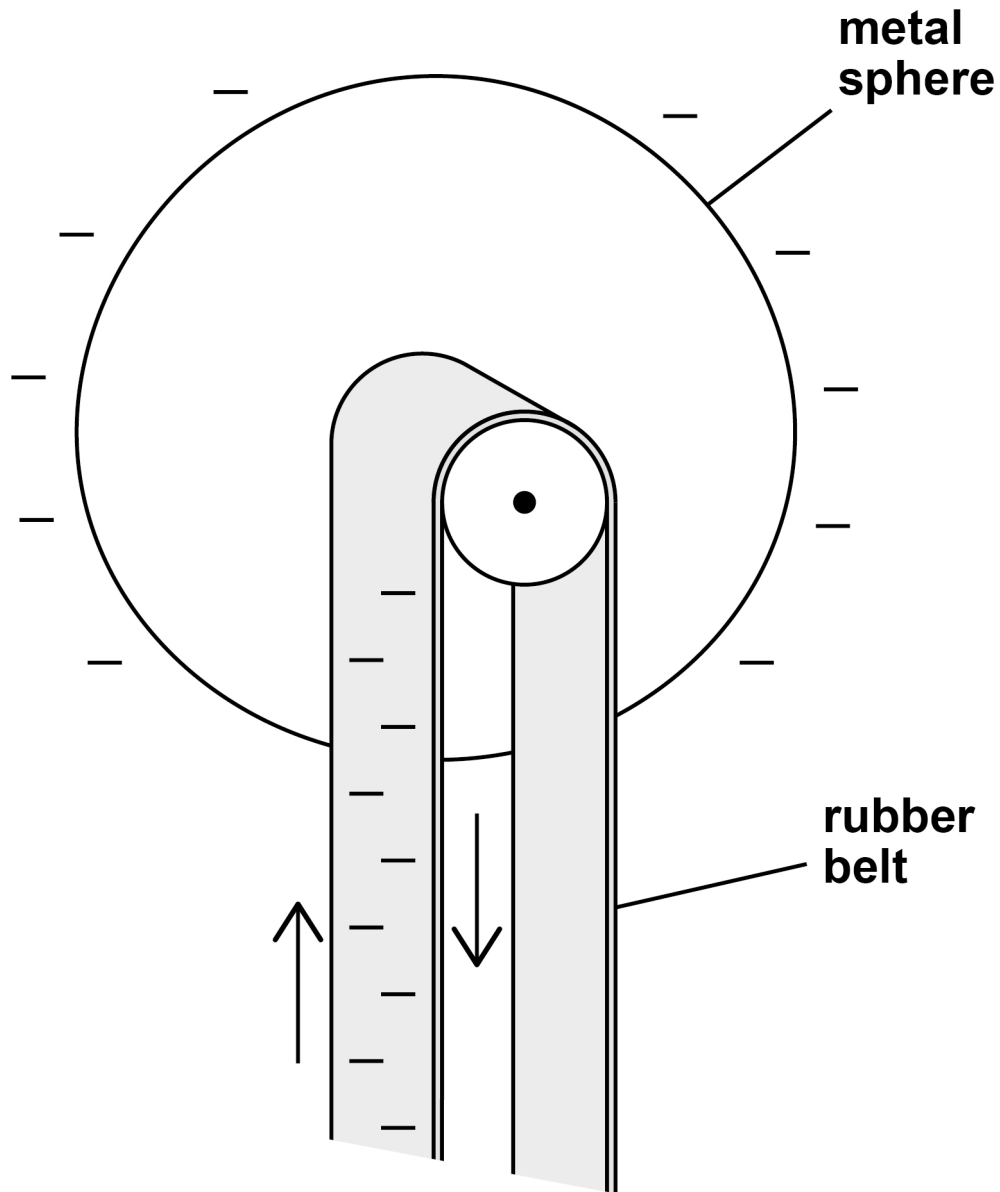

What is the charge collected by the sphere each second? [1 mark]

A  $0.016Q$

B  $0.04Q$

C  $0.25Q$

D  $4Q$

[Turn over]



**2 2**

Charged plates X and Y have a potential difference  $1.5\text{ V}$  between them.

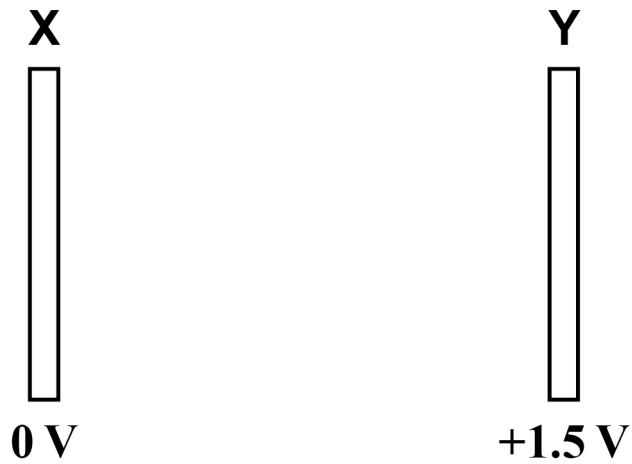

Which particle gains  $3.0\text{ eV}$  of kinetic energy when moving from Y to X? [1 mark]

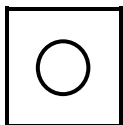

**A** proton

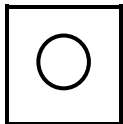

**B** positron

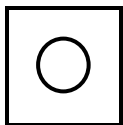

**C** electron

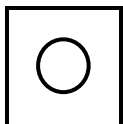

**D** alpha particle



- 2 3** The diagram shows part of a circuit and the currents in the circuit.

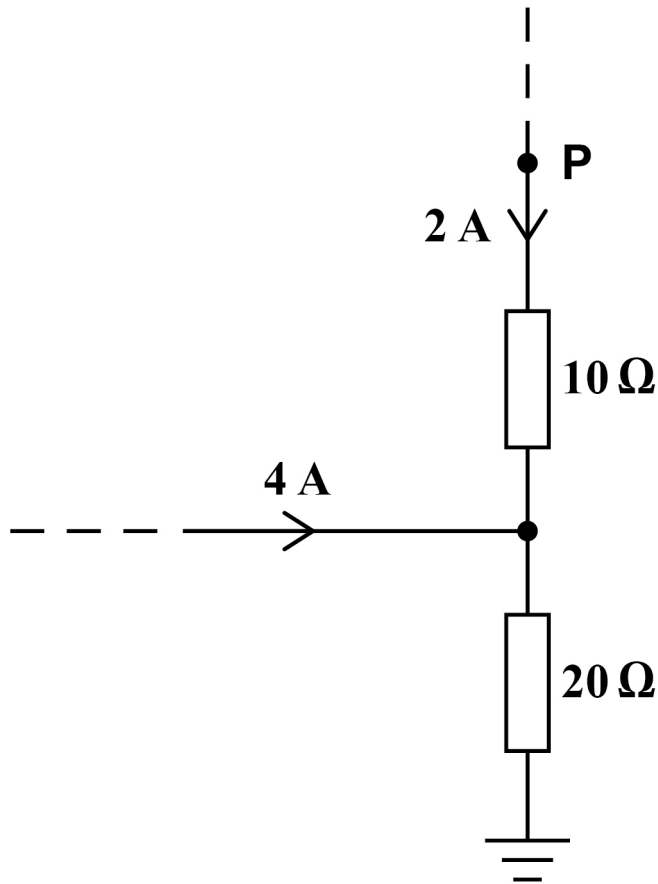

What is the potential difference between point **P** and earth? [1 mark]

- A** 60 V
- B** 100 V
- C** 120 V
- D** 140 V

[Turn over]



**2 4**

A voltmeter has a resistance of  $4.0 \text{ k}\Omega$  and reads  $1.0 \text{ V}$  for every scale division on the meter.

A power supply of emf  $20 \text{ V}$  and negligible internal resistance is connected across this voltmeter and a resistor in series. The voltmeter reads two divisions.

What is the value of the resistor? [1 mark]

**A**  $44 \text{ k}\Omega$

**B**  $36 \text{ k}\Omega$

**C**  $4.4 \text{ k}\Omega$

**D**  $3.6 \text{ k}\Omega$



- 2 5** Two cylindrical wires P and Q are of equal length and made of the same material.  
The diameter of P is greater than that of Q.

P and Q are connected in series and the ends of this arrangement are connected to a power supply.

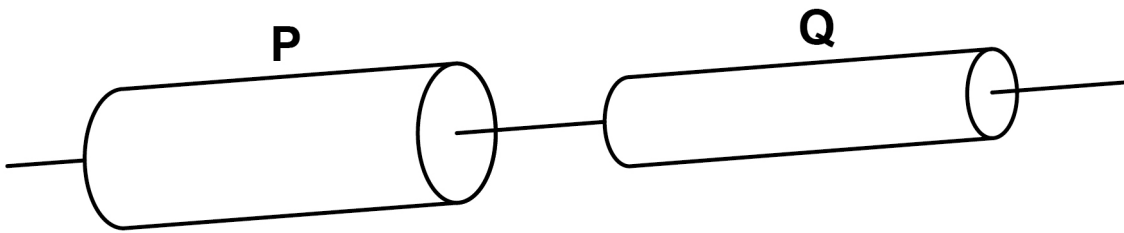

Which two quantities are the same for P and Q?  
[1 mark]





<b>A</b>	<b>potential difference across wire</b>	<b>resistivity</b>
<b>B</b>	<b>resistivity</b>	<b>current</b>
<b>C</b>	<b>current</b>	<b>resistance</b>
<b>D</b>	<b>resistance</b>	<b>potential difference across wire</b>

[Turn over]



2 6

In the circuit below, the initial voltmeter reading is zero.

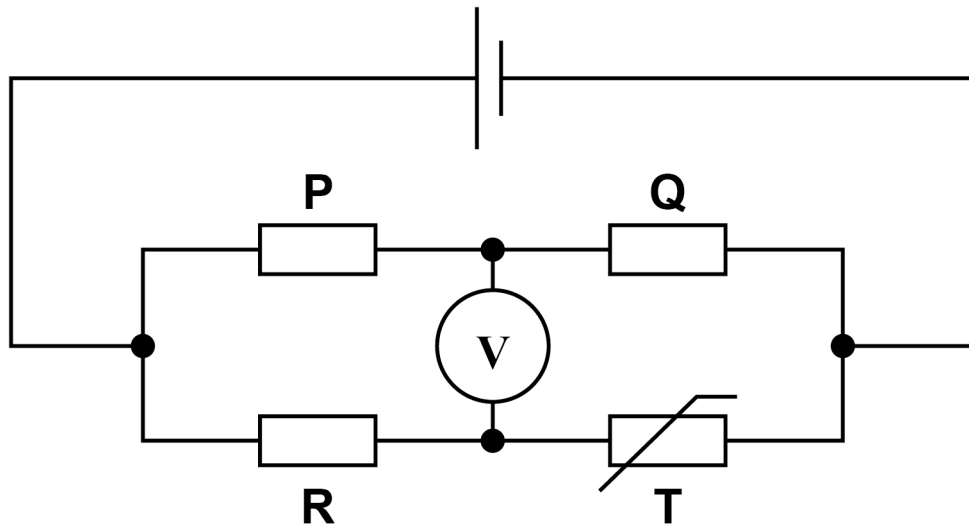

The temperature of the negative temperature coefficient thermistor T is then increased.

Which change to the circuit could restore the voltmeter reading to zero? [1 mark]

**A** Decreasing the resistance of R.

**B** Increasing the resistance of R.

**C** Decreasing the resistance of P.

**D** Increasing the resistance of Q.



**2 7**

An electric motor lifts a load of weight  $W$  through a vertical height  $h$  in time  $t$ .  
The potential difference across the motor is  $V$  and the current through it is  $I$ .

What is the efficiency of the motor? [1 mark]

**A**  $\frac{Wh}{VI}$

**B**  $\frac{VI}{Wh}$

**C**  $\frac{Wh}{VIt}$

**D**  $\frac{VIt}{Wh}$

[Turn over]



**2 8**

An object of mass  $m$  moves in a circle of radius  $r$ . It completes  $n$  revolutions every second.

What is the kinetic energy of the object?  
[1 mark]

**A**  $\frac{mn^2r^2}{8\pi^2}$

**B**  $\frac{mn^2r^2}{4\pi^2}$

**C**  $2m\pi^2n^2r^2$

**D**  $4m\pi^2n^2r^2$



**BLANK PAGE**

**[Turn over]**



- 29** The graph shows the variation of displacement  $d$  with time  $t$  for a particle moving with simple harmonic motion of period  $T$ .

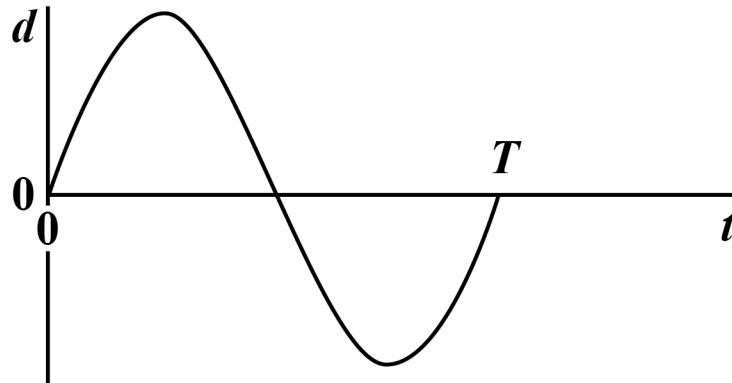

Which graph shows the variation of kinetic energy  $E_k$  of the particle with time? [1 mark]

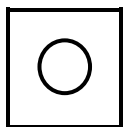

**A**

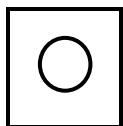
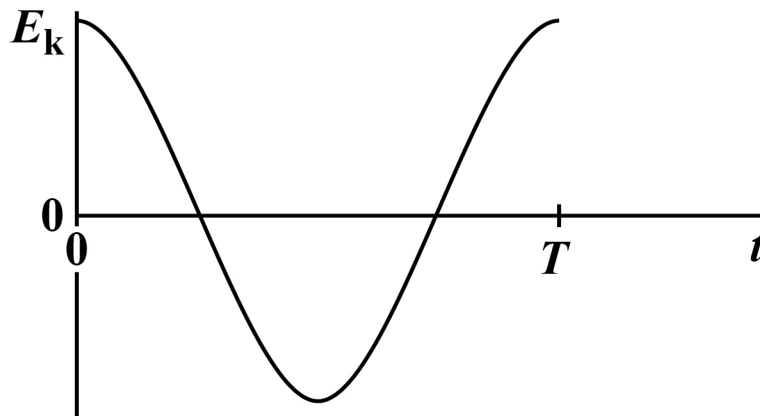

**B**

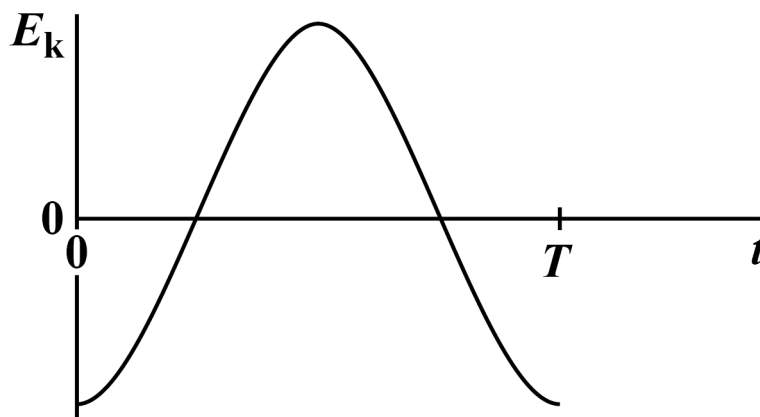

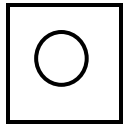
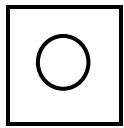
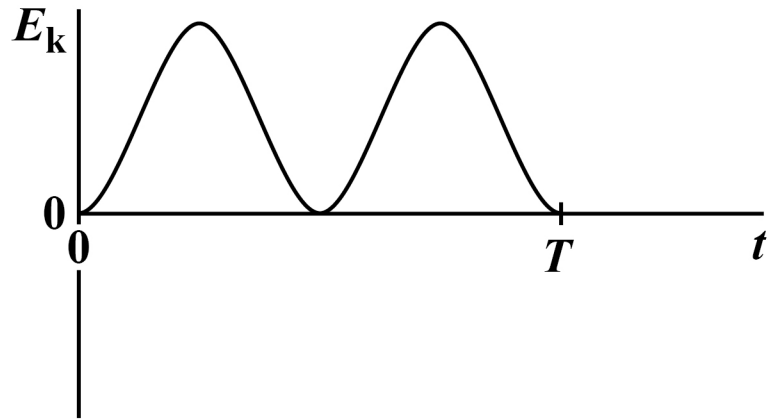
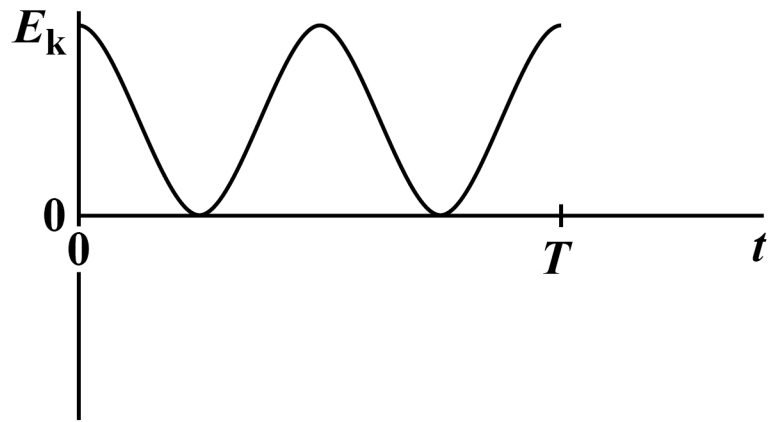
**C****D****[Turn over]**

**3 0**

Two pendulums A and B oscillate with simple harmonic motion.

The time period of A is 2.00 s and the time period of B is 1.98 s.

A and B are released in phase.

What is the number of oscillations of A before A and B are next in phase? [1 mark]

**A 49****B 50****C 99****D 100**

**3 1**

The frequency of oscillation of a vertical spring is  $f$  when the mass hanging from the spring is  $m$ .

What is the relationship between  $f$  and  $m$ ?  
[1 mark]

**A**  $f \propto m^{-\frac{1}{2}}$

**B**  $f \propto m^{-2}$

**C**  $f \propto m^{\frac{1}{2}}$

**D**  $f \propto m^2$

[Turn over]



- 3 2** A metal panel is driven to vibrate at different frequencies. The amplitude  $a$  of the vibration is measured at each frequency. The graph shows the variation of amplitude with driven frequency.

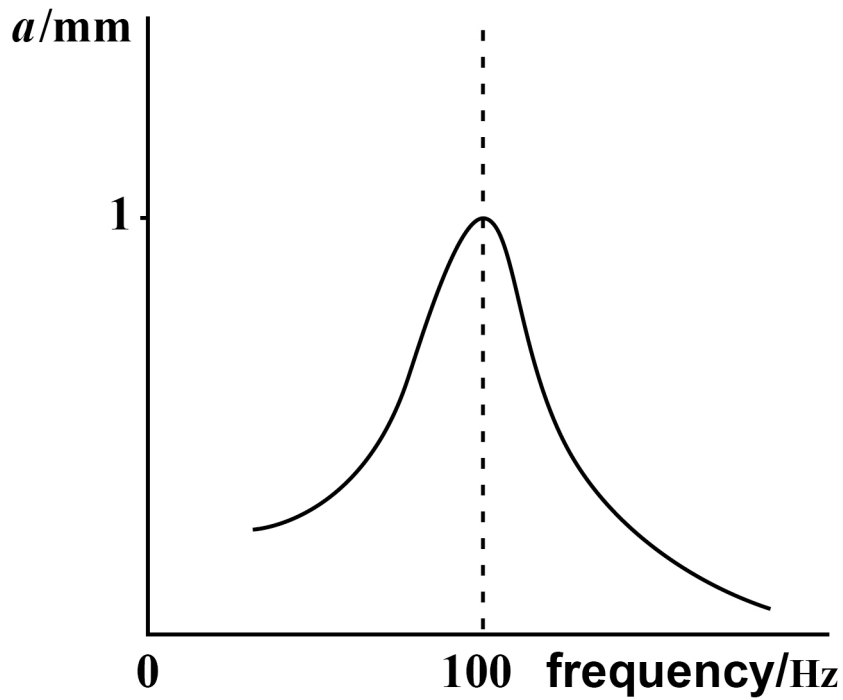

**BLANK PAGE**

**[Turn over]**



The damping of the metal panel is increased without changing the mass of the panel.

Which graph on the opposite page shows the variation of  $a$  with frequency with increased damping? [1 mark]

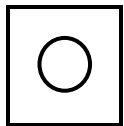
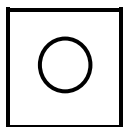
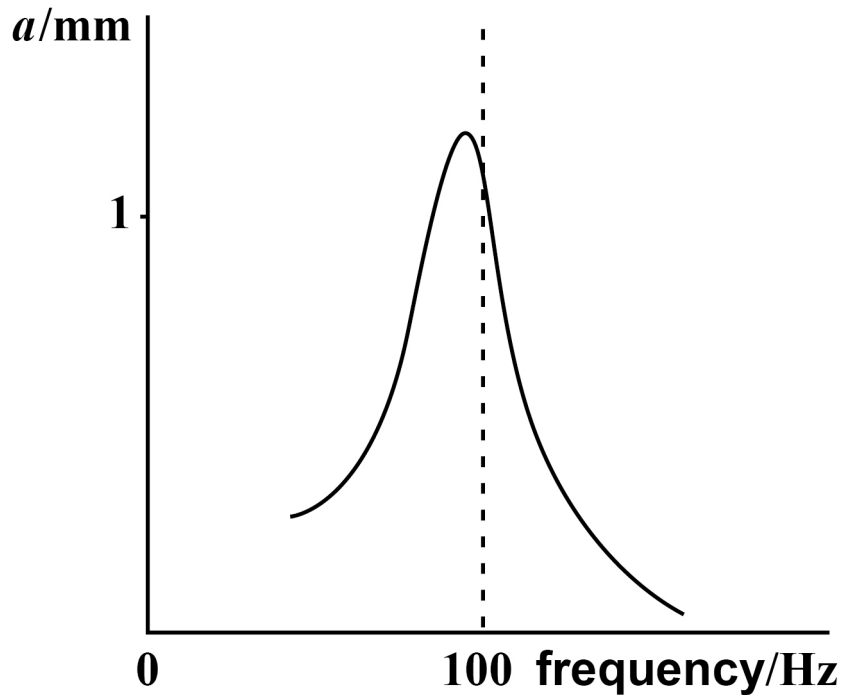
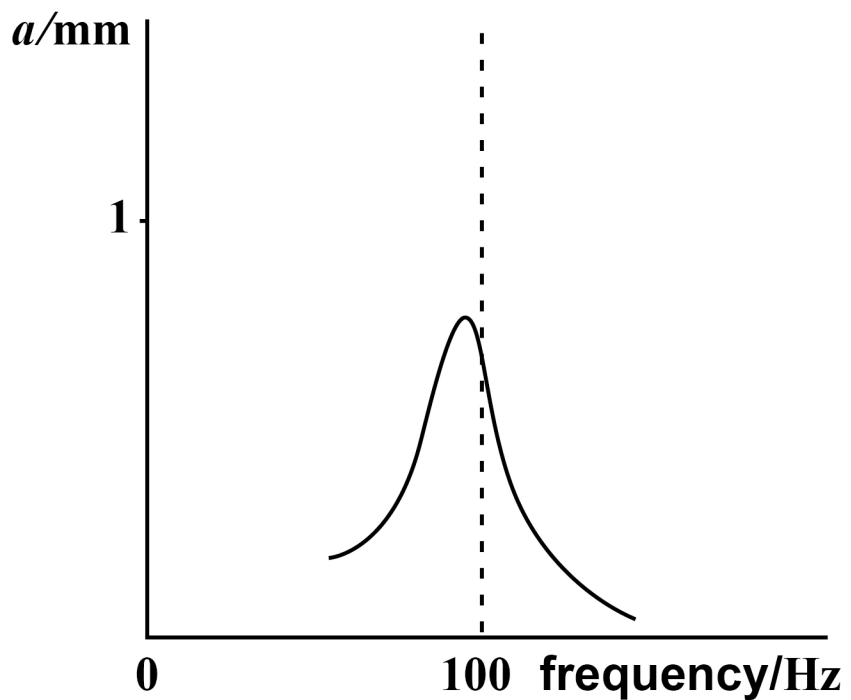
**A****B**

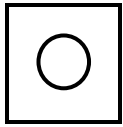
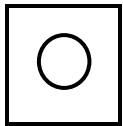
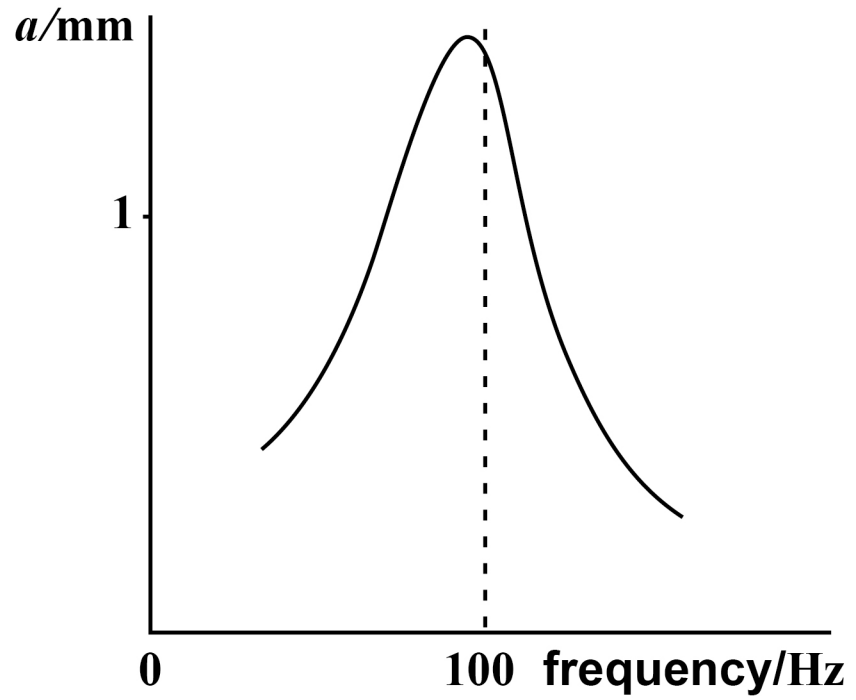
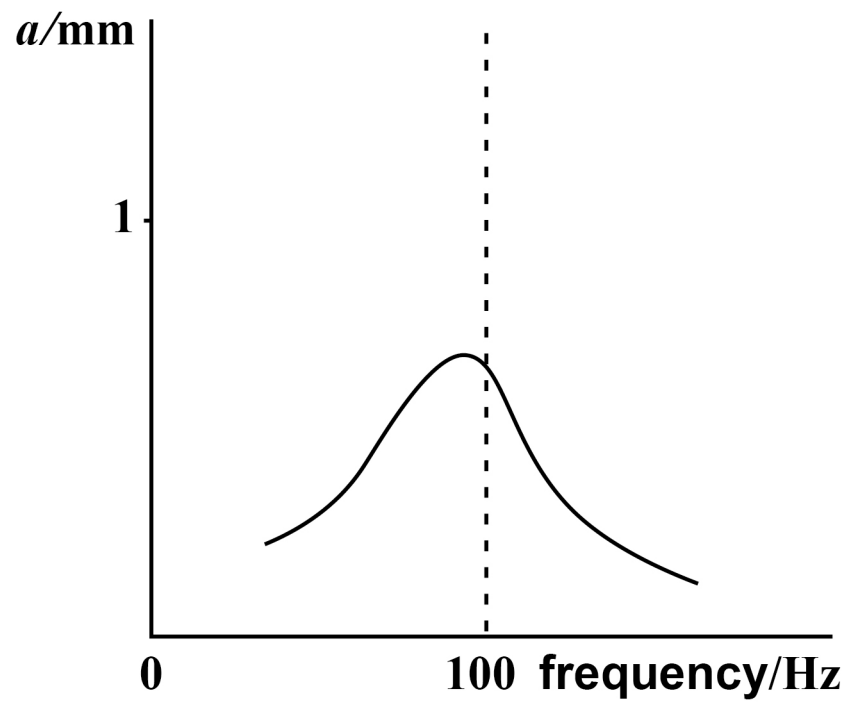
**C****D****END OF QUESTIONS**









**BLANK PAGE**

For Examiner's Use	
Question	Mark
1	
2	
3	
4	
5	
6	
7	
8–32	
<b>TOTAL</b>	

**Copyright information**

For confidentiality purposes, acknowledgements of third-party copyright material are published in a separate booklet rather than including them on the examination paper or support materials. This booklet is published after each examination series and is available for free download from [www.aqa.org.uk](http://www.aqa.org.uk) after the live examination series.

Permission to reproduce all copyright material has been applied for. In some cases, efforts to contact copyright-holders may have been unsuccessful and AQA will be happy to rectify any omissions of acknowledgements. If you have any queries please contact the Copyright Team, AQA, Stag Hill House, Guildford, GU2 7XJ.

Copyright © 2019 AQA and its licensors. All rights reserved.

**IB/M/CD/Jun19/7408/1/E6**