



Surname _____

Forename(s) _____

Centre Number _____

Candidate Number _____

Candidate Signature _____

I declare this is my own work.

A-level

PHYSICS

Paper 3

Section B Engineering physics

7408/3BC

Monday 17 June 2024

Morning

Time allowed: The total time for both sections of this paper is 2 hours. You are advised to spend approximately 50 minutes on this section.

[Turn over]



J U N 2 4 7 4 0 8 3 B C 0 1

On the front of this book, write your surname and forename(s), your centre number, your candidate number and add your signature.

MATERIALS

For this paper you must have:

- **a pencil and a ruler**
- **a scientific calculator**
- **a Data and Formulae Booklet**
- **a protractor.**

INSTRUCTIONS

- **Use black ink or black ball-point pen.**
- **Answer ALL questions.**
- **You must answer the questions in the spaces provided. Do not write on blank pages.**



- **If you need extra space for your answer(s), use the lined pages at the end of this book. Write the question number against your answer(s).**
- **Do all rough work in this book. Cross through any work you do not want to be marked.**
- **Show all your working.**

INFORMATION

- **The marks for questions are shown in brackets.**
- **The maximum mark for this paper is 35.**
- **You are expected to use a scientific calculator where appropriate.**
- **A Data and Formulae Booklet is provided as a loose insert.**

DO NOT TURN OVER UNTIL TOLD TO DO SO



BLANK PAGE



SECTION B

Answer ALL questions in this section.

0 1

A heavy turntable is mounted on a fixed base. The turntable can rotate freely on a low-friction bearing.

0 1 . 1

FIGURE 1, on page 6, shows a propeller unit fixed to the centre of the turntable.

The propeller unit consists of a motor-driven propeller and a battery.

The propeller and the turntable have a common axis of rotation.

[Turn over]

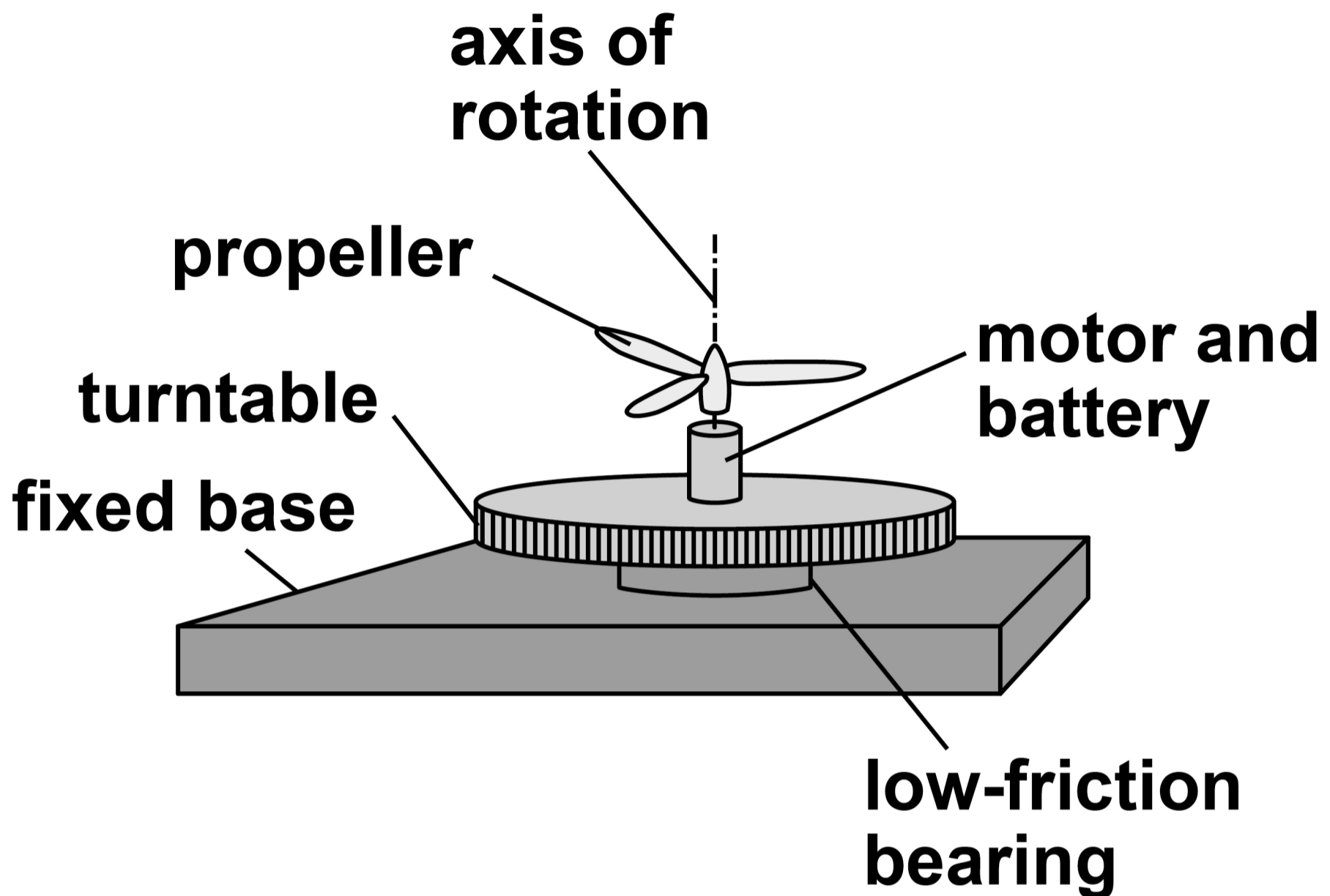

FIGURE 1

At first, the turntable and the propeller are at rest.

The propeller motor is switched on and the propeller quickly reaches a high final angular speed.

The propeller rotates clockwise when viewed from above.



01.2

FIGURE 2 shows an arrangement used to determine the moment of inertia of the turntable.

FIGURE 2

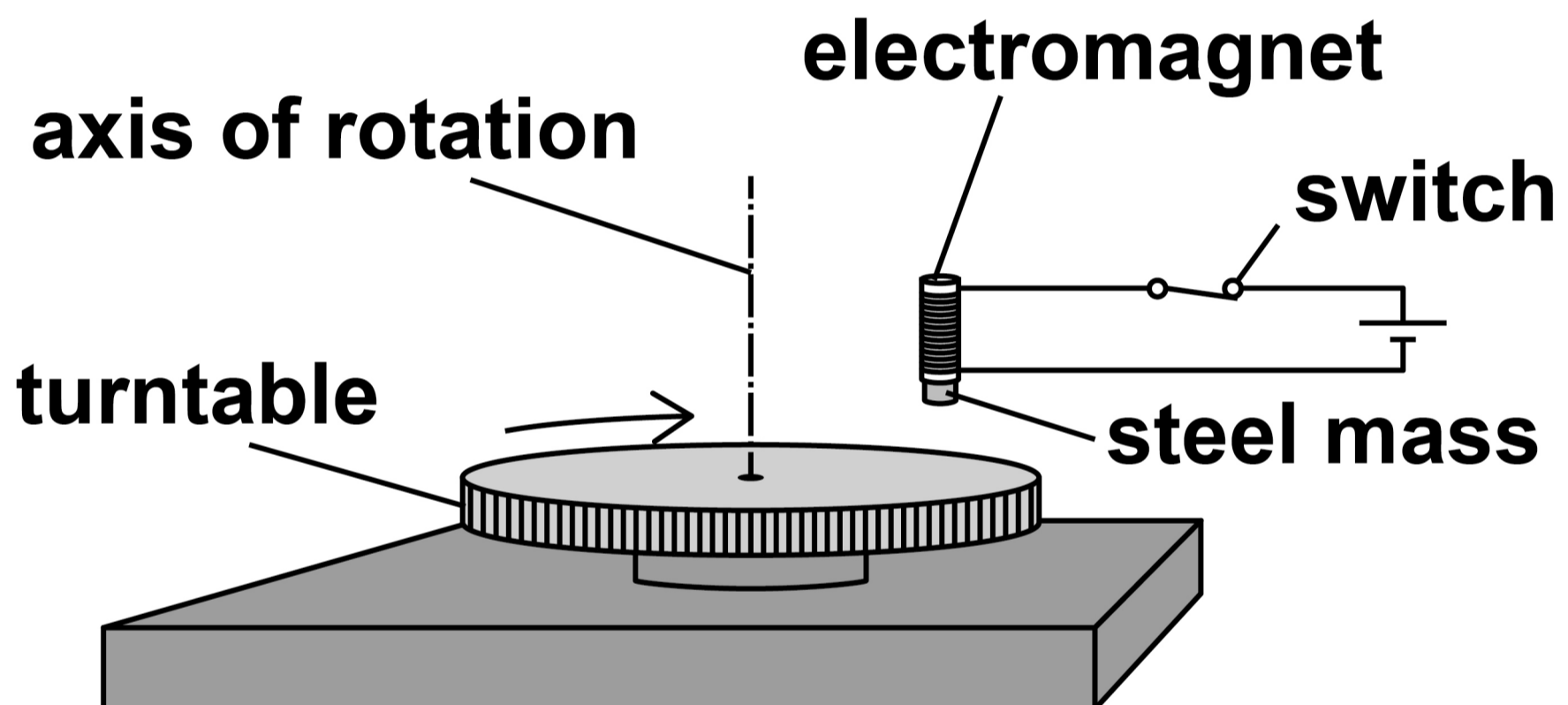

A small steel mass is held by an electromagnet above the top surface of the turntable. The diameter of the turntable is about half a metre.

The turntable rotates freely at an initial angular speed ω_1 .

The switch is opened so that the mass falls and sticks to the surface of the turntable. This changes the angular speed of the turntable to ω_2 .

The steel mass can be considered to be a point mass.

[Turn over]



Describe how to determine the moment of inertia of the turntable using observations of ω_1 and ω_2 .

In your answer you should:

- suggest how ω_1 and ω_2 are measured**
- state any other measurements needed and name the equipment used to make them**
- explain how the moment of inertia of the turntable is determined from the measurements.**

[6 marks]



BLANK PAGE



0 2

FIGURE 3 shows an excavator.

FIGURE 3

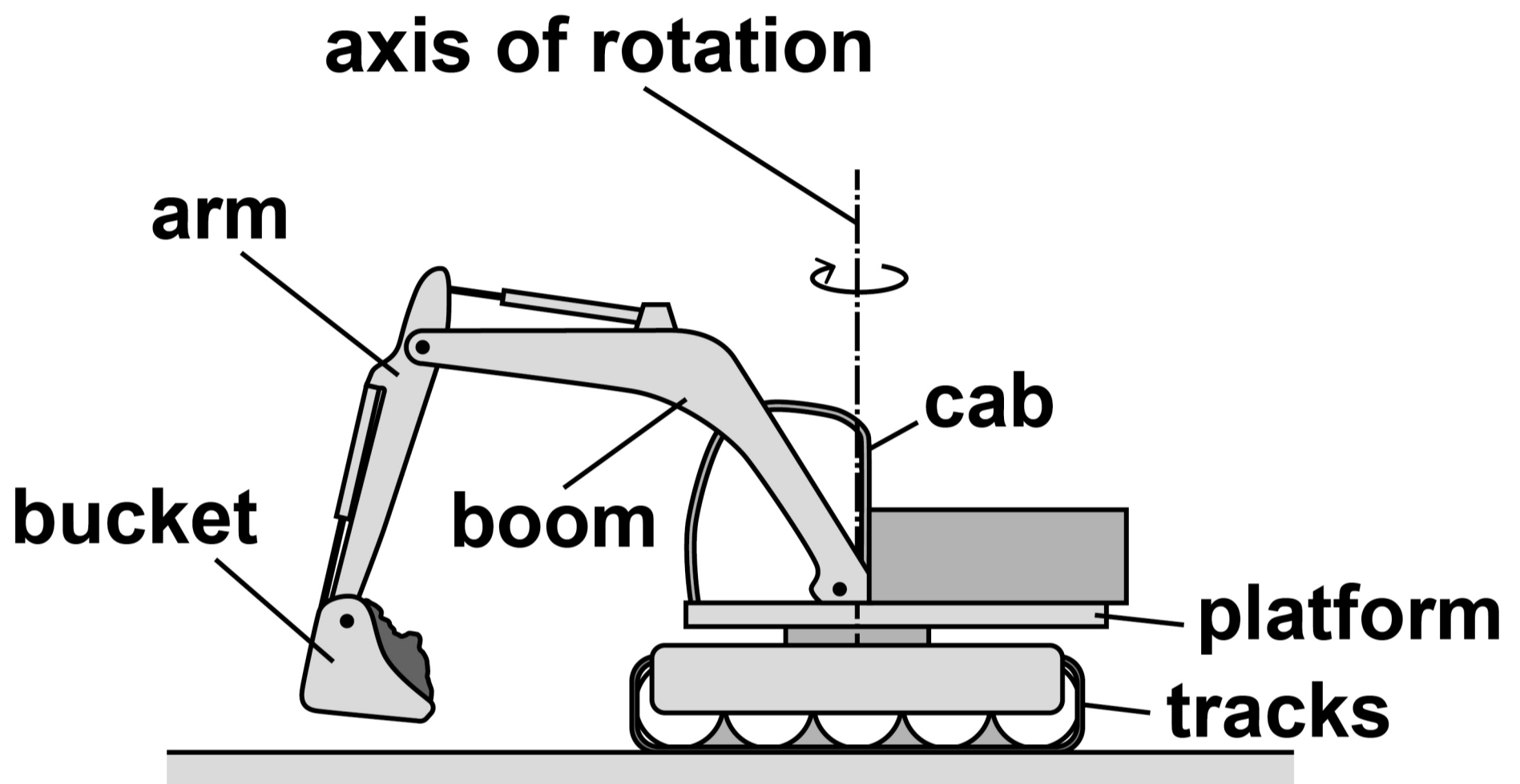

The bucket position can be changed by moving the boom and arm and by rotating the platform about the vertical axis of rotation.

For the purposes of this question, assume that the excavator tracks do not move.

[Turn over]



The bucket is moved to a new position by rotating the platform about the axis of rotation.

FIGURE 4 shows the variation in angular velocity ω with time t for the rotation of the platform about the vertical axis.

FIGURE 4

VERTICAL AXIS IS NOT TO SCALE

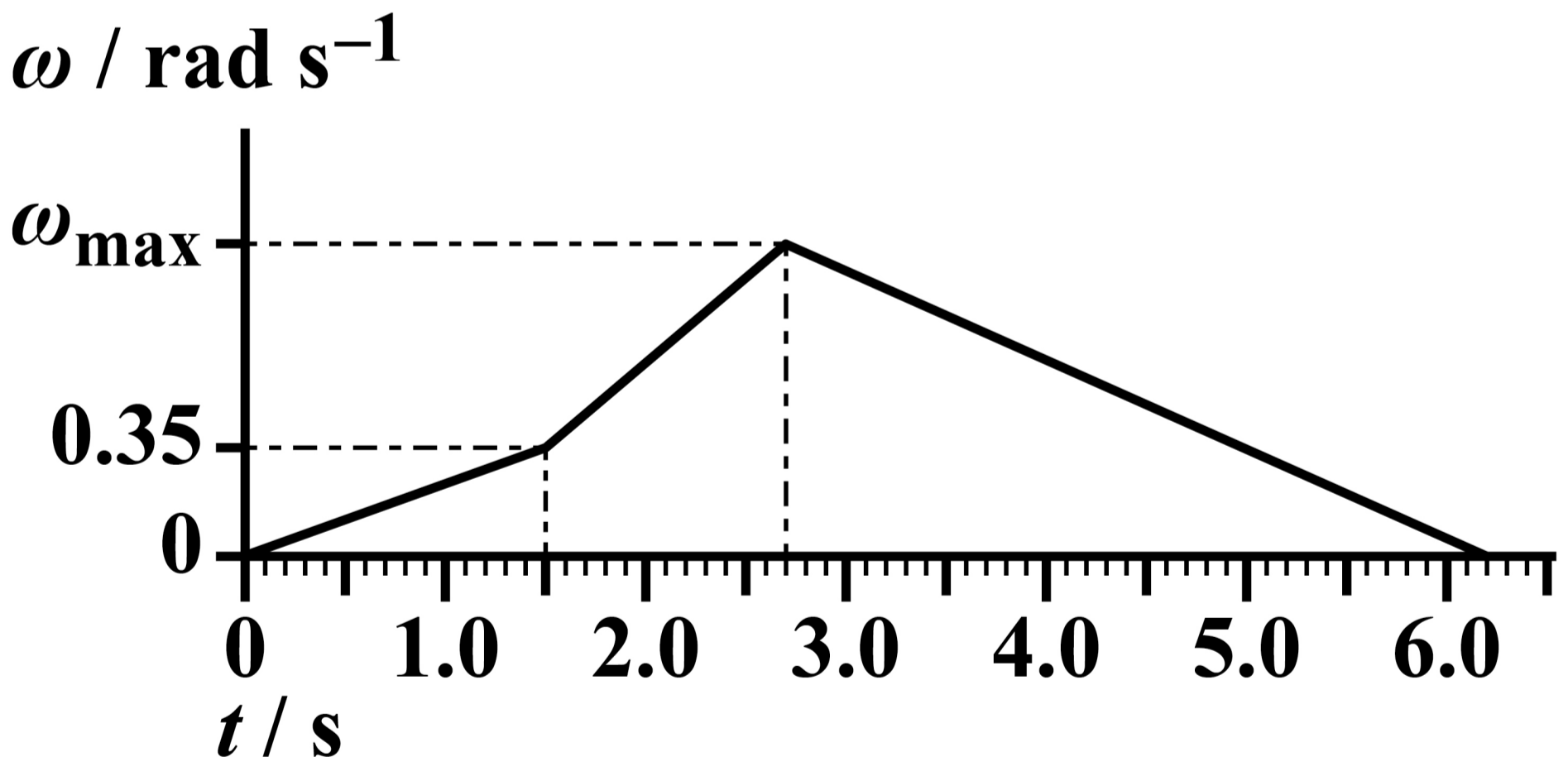

0 2 . 1

The total angular displacement of the platform is 2.52 rad during the movement of the bucket.

**Show that ω_{\max} is about 0.9 rad s⁻¹.
[3 marks]**

[Turn over]



At the same time as the platform is rotating, the bucket is moved up and down, and away from and towards the cab.

The moment of inertia of the rotating parts of the excavator about the axis of rotation is I .

FIGURE 5 shows how I varies with t for the same time period as FIGURE 4, on page 16.

FIGURE 5

$I / 10^3 \text{ kg m}^2$

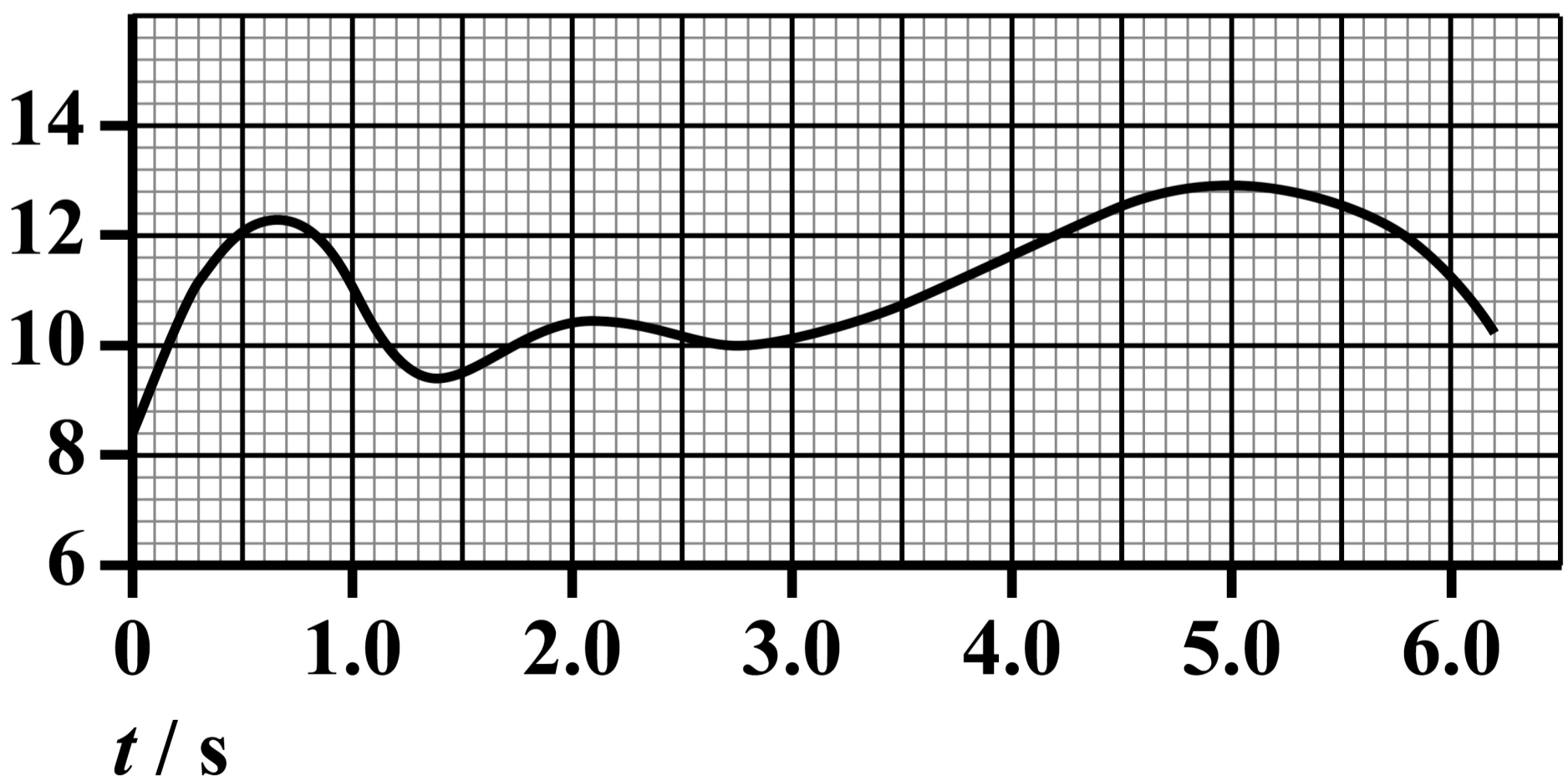

02.2

Torque must be applied to the platform to change its angular velocity and to overcome friction at the platform bearing.

Show that the torque applied to the platform is at a maximum at time $t = 2.1$ s. [3 marks]

[Turn over]



0 2 . 3

Deduce whether the maximum power applied to the platform occurs at the same time of 2.1 s. [2 marks]

8

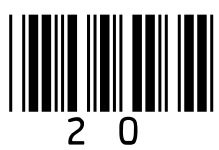

BLANK PAGE

[Turn over]



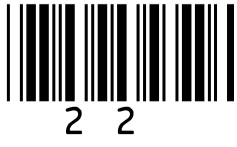

0 3

The Lenoir engine was the first successful internal combustion engine.

FIGURE 6, on the opposite page, shows the basic form of the Lenoir engine. The piston rod drives a crankshaft which is not shown. The fuel is a mixture of gas and air.



FIGURE 6

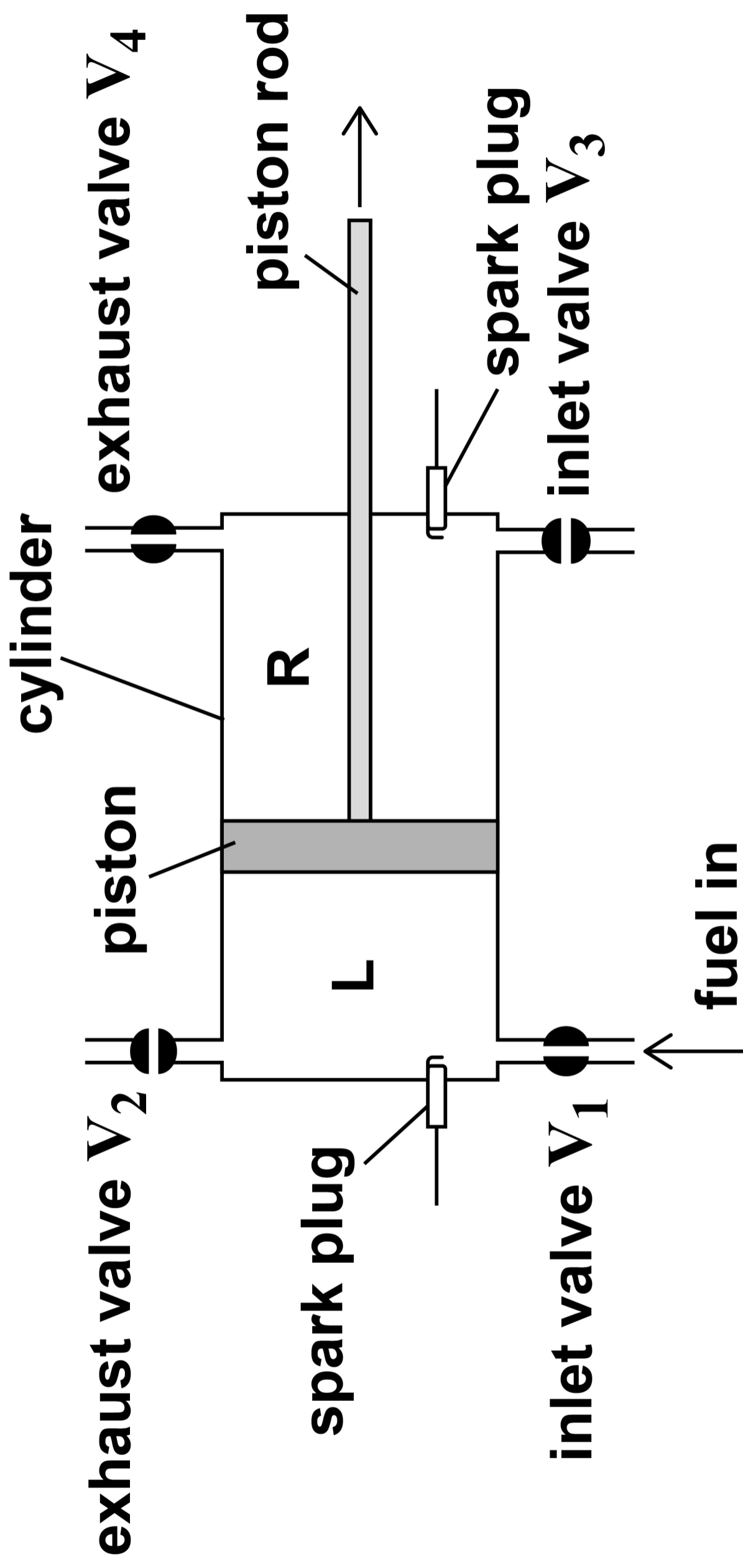

KEY



valve open



valve closed

[Turn over]

FIGURE 7 shows an indicator diagram for the space L, taken during a test on a Lenoir engine.

FIGURE 7

pressure / 10^5 Pa

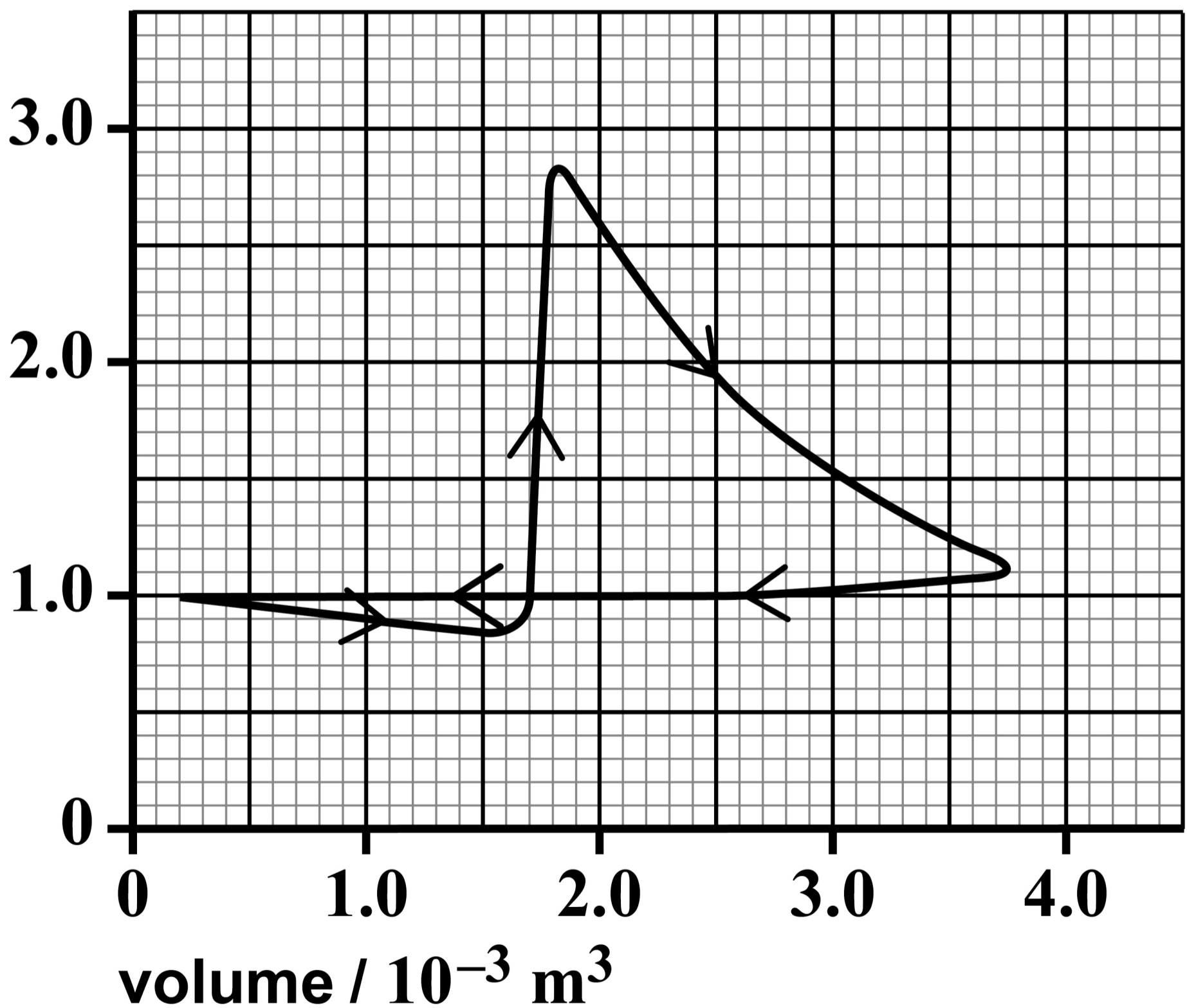

In one cycle the following changes occur in L.

- **INDUCTION.** The piston starts at the left-hand end of the cylinder. It moves to the right and fuel passes through the open inlet valve V_1 into L.
FIGURE 6, on page 23, shows the piston during this induction process, with V_1 open.
- **IGNITION.** When the piston is nearly halfway along the cylinder, V_1 is closed. A spark ignites the fuel causing a sudden rise in pressure.
- **EXPANSION.** The hot gases expand and the piston moves to the end of the stroke.

[Turn over]



- **EXHAUST.** The exhaust valve V_2 opens. The piston moves to the left. The exhaust gases are expelled at atmospheric pressure.

The same processes are repeated in space R one half of a revolution of the crankshaft later than in L. So when the piston is moving to the left, induction, ignition and expansion occur in R at the same time as the exhaust process occurs in L.

0 3 . 1

The indicator diagram is for a rotational speed of the crankshaft of 120 rev min^{-1} .

Determine, using FIGURE 7, on page 24, the indicated power of the engine.

Assume that the indicator diagram for R is identical to the indicator diagram for L.
[5 marks]



indicated power = _____ W

[Turn over]



03.2

The following data are taken during the test on the engine:

fuel consumption = $6.44 \times 10^{-4} \text{ m}^3 \text{ s}^{-1}$

calorific value of fuel = $18.0 \times 10^6 \text{ J m}^{-3}$

torque at crankshaft = 39.0 N m

rotational speed = 120 rev min^{-1}

Calculate the input power and the output (brake) power of the engine. [2 marks]



input power = _____ W

output power = _____ W

[Turn over]



0	3	.	3
---	---	---	---

The output power of a four-stroke petrol engine of a similar working volume to that of the Lenoir engine is about 150 kW.

Suggest TWO reasons for the very low output power of the Lenoir engine compared with a four-stroke petrol engine. [2 marks]

1 _____

2 _____

[Turn over]



0	3	.	4
---	---	---	---

Which statement is correct? [1 mark]

Tick (✓) ONE box.

Thermal efficiency is a measure of how much of the indicated power is converted into output power.

Overall efficiency is the product of mechanical efficiency and thermal efficiency.

Mechanical efficiency is equal to friction power divided by indicated power.

Input power is equal to indicated power plus friction power.

10



BLANK PAGE

[Turn over]



0	4	.	1
---	---	---	---

The first law of thermodynamics can be expressed by the equation $Q = \Delta U + W$.

State the meaning of each term in this equation. [2 marks]

Q _____

ΔU _____

W _____



BLANK PAGE

[Turn over]



04.2

A system consists of a perfectly insulated room containing only an empty refrigerator. The refrigerator is connected to the mains electricity and the refrigerator door is open.

Deduce, by applying the first law of thermodynamics, whether the internal energy of the room increases, decreases or stays the same. [3 marks]



[Turn over]



One definition of an ideal heat engine is:

‘a device which provides the maximum possible output of work from a given input of energy by heat transfer.’

FIGURE 8, on the opposite page, shows a heat engine that appears to agree with this definition. The engine takes in energy from a high-temperature source and work is done by the engine.

0 4 . 3

Complete FIGURE 8 so that the engine obeys the second law of thermodynamics. [1 mark]

FIGURE 8

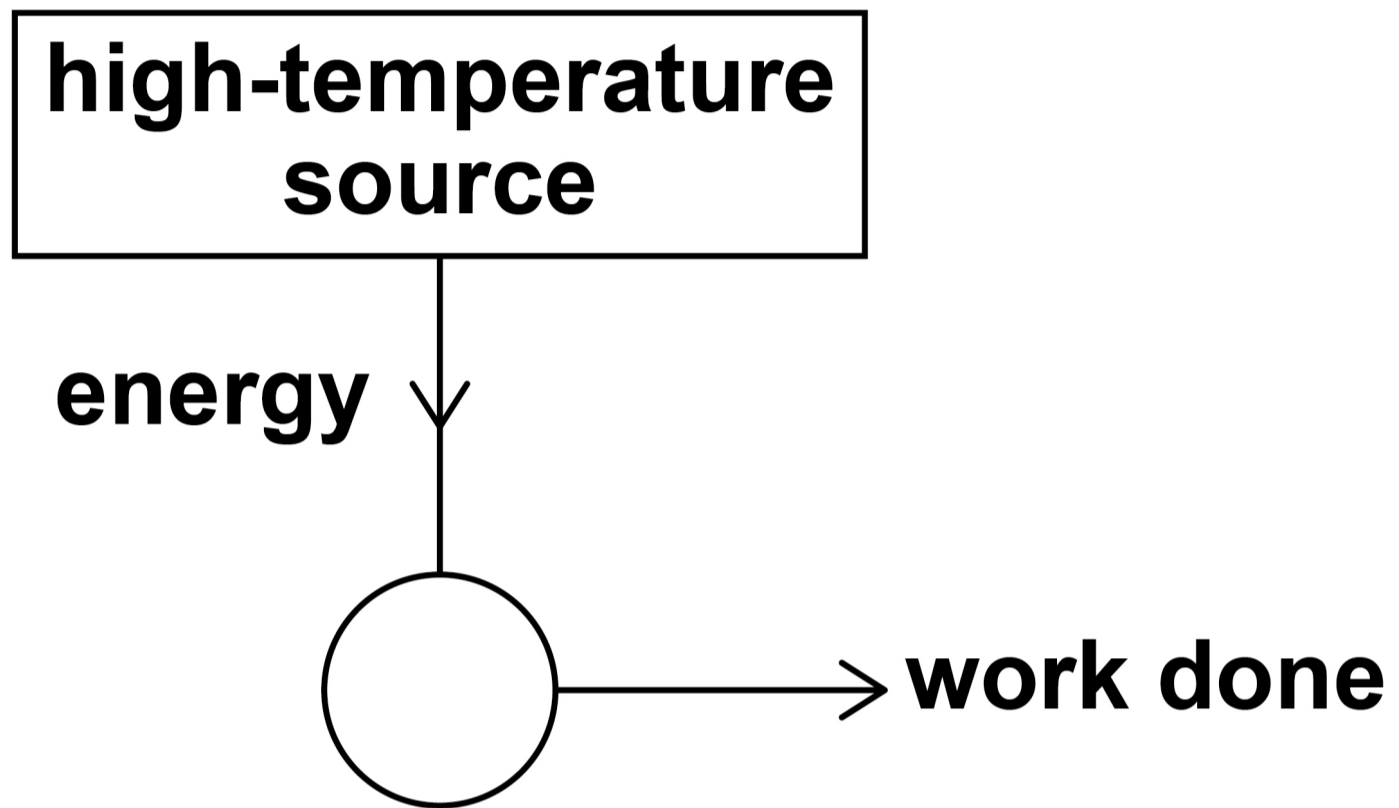

[Turn over]



BLANK PAGE

For Examiner's Use	
Question	Mark
1	
2	
3	
4	
TOTAL	

Copyright information

For confidentiality purposes, all acknowledgements of third-party copyright material are published in a separate booklet. This booklet is published after each live examination series and is available for free download from www.aqa.org.uk

Permission to reproduce all copyright material has been applied for. In some cases, efforts to contact copyright-holders may have been unsuccessful and AQA will be happy to rectify any omissions of acknowledgements. If you have any queries please contact the Copyright Team.

Copyright © 2024 AQA and its licensors. All rights reserved.

WP/M/CD/Jun24/7408/3BC/V4