



GCSE

3300U10-1

MONDAY, 14 NOVEMBER 2022 – MORNING

MATHEMATICS

UNIT 1: NON – CALCULATOR

FOUNDATION TIER

**1 hour 30 minutes plus your additional
time allowance**

**THE USE OF A CALCULATOR IS NOT
PERMITTED IN THIS EXAMINATION**

Surname: _____

First name(s): _____

Centre Number: _____

Candidate Number: 0

For Examiner's use only

Question	Maximum Mark	Mark Awarded
1.	6	
2.	2	
3.	2	
4.	5	
5.	2	
6.	2	
7.	2	
8.	3	
9.	3	
10.	2	
11.	3	
12.	2	
13.	2	
14.	2	
15.	3	
16.	4	
17.	3	
18.	3	
19.	3	
20.	2	
21.	2	
22.	2	
23.	5	
Total	65	

(Turn over)

ADDITIONAL MATERIALS

A ruler, a protractor and a pair of compasses may be required.

ITEMS INCLUDED WITH QUESTION PAPER

A separate Formula List.

A separate Diagram Booklet.

Cut out shapes for Question 13.

The Diagram Booklet **MUST be handed in to the invigilators and sent for marking.**

(Turn over)

INSTRUCTIONS TO CANDIDATES

Use black ink, black ball – point pen, black felt tip or your usual method.

Write your name, centre number and candidate number in the spaces on the front cover.

Answer ALL questions.

Write your answers in the spaces provided.

If you run out of space, use the additional page(s) at the back of the booklet. Question numbers must be given for the work written on the additional page(s).

Take π as 3.14

(Turn over)

INFORMATION FOR CANDIDATES

You should give details of your method of solution when appropriate.

Unless stated, diagrams are not drawn to scale.

Scale drawing solutions will not be acceptable where you are asked to calculate.

The number of marks is given in brackets at the end of each question or part – question.

In question 4, the assessment will take into account the quality of your organisation, communication and accuracy in writing.

(Turn over)

- 1. (a) Write the number
sixty – three thousand and
twenty – nine in figures.**

[1 mark]

continued on the next page . . .

(Turn over)

Question 1 continued

1. (b) Write 2481 correct to the nearest 10

[1 mark]

continued on the next page . . .

(Turn over)

Question 1 continued

1. (c) Multiply 291 by 7

[1 mark]

continued on the next page . . .

(Turn over)

Question 1 continued

1. (d) Subtract 513 from 842

[1 mark]

continued on the next page . . .

(Turn over)

Question 1 continued

**1. (e) A number is multiplied by 4
and then doubled.**

The answer is 56

What is the number?

The number is _____

[2 marks]

(Turn over)

2. Write down the next number in each of the following sequences.

(a) 67 73 79 85 _____

[1 mark]

(b) 103 92 81 70 _____

[1 mark]

(Turn over)

3. Look at the diagram for Question 3 in the separate Diagram Booklet.

The diagram shows a shape drawn on a grid of squares.

Each square on the grid represents 1 cm^2

Estimate the area of the shape.

(Turn over)

12

Area of the shape

= _____ cm²

[2 marks]

(Turn over)

4. IN THIS QUESTION, YOU WILL BE ASSESSED ON THE QUALITY OF YOUR ORGANISATION, COMMUNICATION AND ACCURACY IN WRITING.

A customer buys 7 identical small boxes and 3 identical large boxes from a shop. The total cost of these boxes is £59

Each small box costs £5

How much does each large box cost?

You must show all your working.

(Turn over)

15

[3 marks + 2 marks OCW]

(Turn over)

5. Here is a list of eight numbers.

7 4 9 5 4 5 3 4

(a) What is the range of these eight numbers?

Range = _____

[1 mark]

continued on the next page . . .

(Turn over)

Question 5 continued

Here is a list of eight numbers.

7 4 9 5 4 5 3 4

- 5. (b) What is the mode of the eight numbers listed above?**

Circle the correct answer.

3	4	5	7	9
----------	----------	----------	----------	----------

[1 mark]

(Turn over)

6. (a) Write these numbers in order, starting with the smallest number.

-2 -5 4 0

smallest

biggest

[1 mark]

continued on the next page . . .

(Turn over)

Question 6 continued

- 6. (b) Write these numbers in order, starting with the smallest number.**

3.78**3.91****3.69****3.8****smallest****biggest****[1 mark]****(Turn over)**

7. Mary has 6 oranges and 11 apples in a bag.

She chooses one piece of fruit from the bag at random.

What is the probability that Mary chooses an apple?

[2 marks]

(Turn over)

8. Look at the diagram for Question 8 in the separate Diagram Booklet. The diagram is NOT drawn to scale.

In the diagram, there are two angles shown, 240° and $6y^\circ$.

Calculate the value of y .

(Turn over)

$y =$ _____

[3 marks]

(Turn over)

9. A car passes through four places in the following order:

Aber, Berw, Ceiro and Dinas.

The car passes through Aber, Berw and Ceiro at the times shown in the table below.

PLACE	TIME
Aber	13:30
Berw	14:40
Ceiro	16:30
Dinas	

continued on the next page . . .

(Turn over)

Question 9 continued

**The time taken to travel from
Aber to Berw is TWICE the time
taken to travel from Ceiro to Dinas.**

**At what time does the car pass
through Dinas?**

You must show all your working.

(Turn over)

10. Solve the following equations.

(a) $11k = 99$

[1 mark]

continued on the next page . . .

(Turn over)

Question 10 continued

10. (b) $18 - p = 6$

[1 mark]

(Turn over)

11. Look at the diagram for Question 11 in the separate Diagram Booklet.

The diagram is NOT drawn to scale.

The diagram shows triangle *ABC*.

Use a ruler and a protractor to make an accurate drawing of triangle *ABC* in the space below the diagram.

[3 marks]

(Turn over)

12. Using only the numbers in the following list,

31 33 35 37 39 41 43

find

(a) the multiple of 5.5

The multiple of 5.5 is _____

[1 mark]

continued on the next page . . .

(Turn over)

Question 12 continued

Using only the numbers in the following list,

31 33 35 37 39 41 43

find

12. (b) the factor of 111

The factor of 111 is _____

[1 mark]

(Turn over)

13. Look at the diagram for Question 13 in the separate Diagram Booklet. The diagram shows some shaded squares on a grid.

Shade the least number of squares so that the grid has rotational symmetry of order 2

The squares you shade must be in the lower two quadrants.

Cut out squares are available for this question.

[2 marks]

(Turn over)

14. Two friends, Geraint and Dyfrig, are having a discussion.

(a) Geraint says,

“All prime numbers are odd numbers.”

Explain why Geraint is incorrect.

(Turn over)

[1 mark]

14. (b) Dyfrig says,

“All cube numbers are odd numbers.”

Explain why Dyfrig is incorrect.

(Turn over)

34

[1 mark]

(Turn over)

15. Andrew and Grace each have some £10 notes and £5 notes.

Andrew has 6 notes.

The total value of Andrew's notes is £55

Grace has 5 notes.

The total value of Grace's notes is £35

How many £10 notes do they have in total?

How many £5 notes do they have in total?

Total number of £10 notes

= _____

Total number of £5 notes

= _____

[3 marks]

(Turn over)

Question 16 continued

16. (b) Simplify the expression

$$6c - 7d - 2c - 8d$$

[2 marks]

(Turn over)

17. In a restaurant, as part of a Set Meal, customers must choose a starter, main course and dessert from the options below.

SET MEAL		
STARTER	MAIN COURSE	DESSERT
Melon (M) or Soup (S)	Chicken (C) or Ham (H) or Pizza (P)	Fruit (F) or Yoghurt (Y)

continued on the next page . . .

(Turn over)

Question 17 continued

**Look at the table for Question 17
in the separate Diagram Booklet.**

**List all the possible different
combinations of starters,
main courses, and desserts that
the restaurant offers.**

One has been done for you.

[3 marks]

(Turn over)

**18. There are five numbers in a list.
The mean of the five numbers is 7
Another number is added to the list.
The mean of these six numbers
is 8.5**

**Find the value of the sixth number.
You must show all your working.**

(Turn over)

43

[3 marks]

(Turn over)

19. A sum of money is shared in the ratio 1 : 8

The LARGER share is £16.80

What is the total amount of money shared?

You must show all your working.

(Turn over)

46

[3 marks]

(Turn over)

[2 marks]

(Turn over)

21. The n th term of a sequence is given by $3n - 13$

Write down the value of

(a) the 10th term,

[1 mark]

continued on the next page . . .

(Turn over)

Question 21 continued

21. (b) the 4th term.

[1 mark]

(Turn over)

22. Samira has a dice.

Its faces are numbered 1 to 6

**She wants to know whether her
dice is biased or not.**

Samira rolled this dice 300 times.

Look at the table for Question 22

in the separate Diagram Booklet.

Her results are shown in the table.

The relative frequency of

throwing a 5 is $\frac{23}{300}$

continued on the next page . . .

(Turn over)

Question 22 continued

What is the relative frequency of throwing a 2?

Give your answer as a fraction in its simplest form.

[2 marks]
(Turn over)

23. Look at the diagram for Question 23 in the separate Diagram Booklet.

The diagram is NOT drawn to scale.

The diagram shows a rectangle and a square.

The total area of the two shapes is 184 cm^2

Find the PERIMETER of the square.

(Turn over)

[5 marks]

END OF PAPER

TOTAL 65 MARKS

(Turn over)



GCSE

3300U10-1

MONDAY, 14 NOVEMBER 2022 – MORNING

MATHEMATICS

UNIT 1: NON – CALCULATOR

FOUNDATION TIER

**The Diagram Booklet MUST
be handed in to the invigilators
and sent for marking.**

Diagram Booklet

Surname: _____

First name(s): _____

Centre Number: _____

Candidate Number: 0 _____

Question 3

Each square on the grid represents 1 cm^2

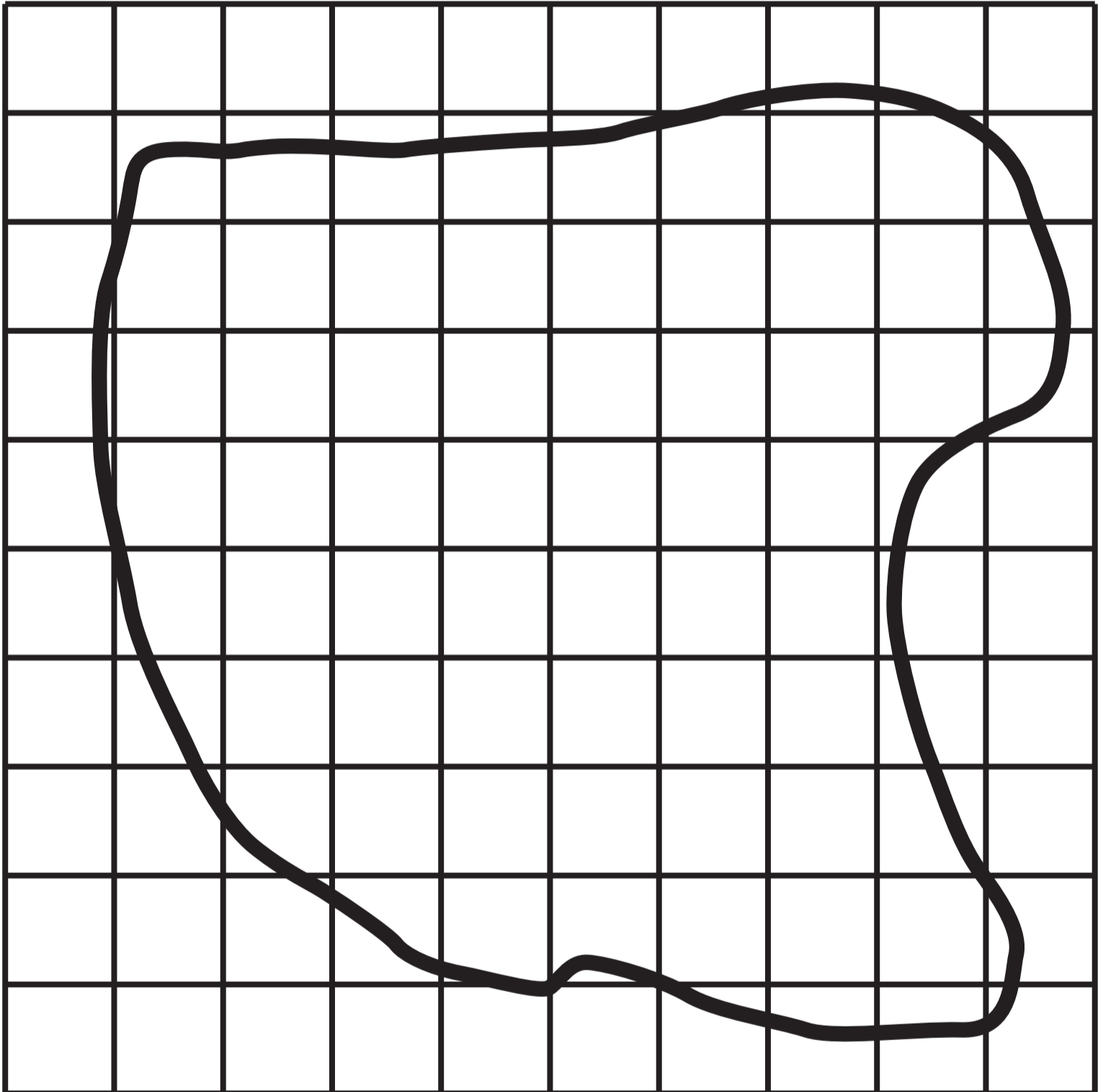

Question 8

Diagram NOT drawn to scale

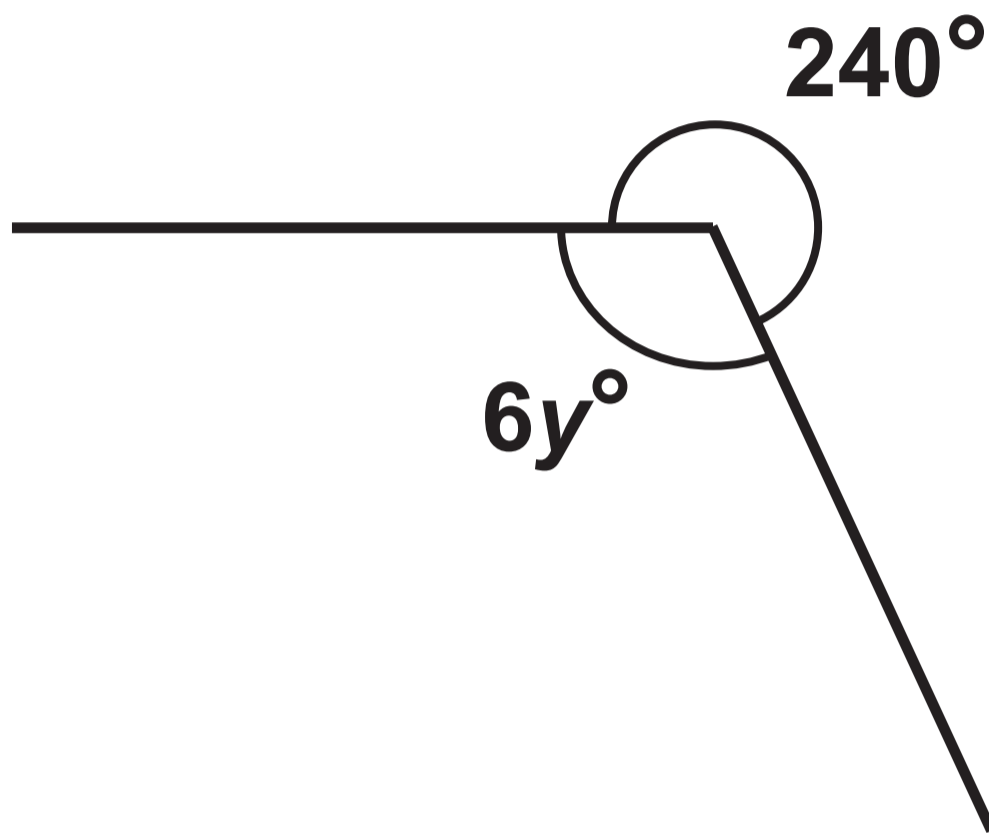

Question 11

Diagram NOT drawn to scale

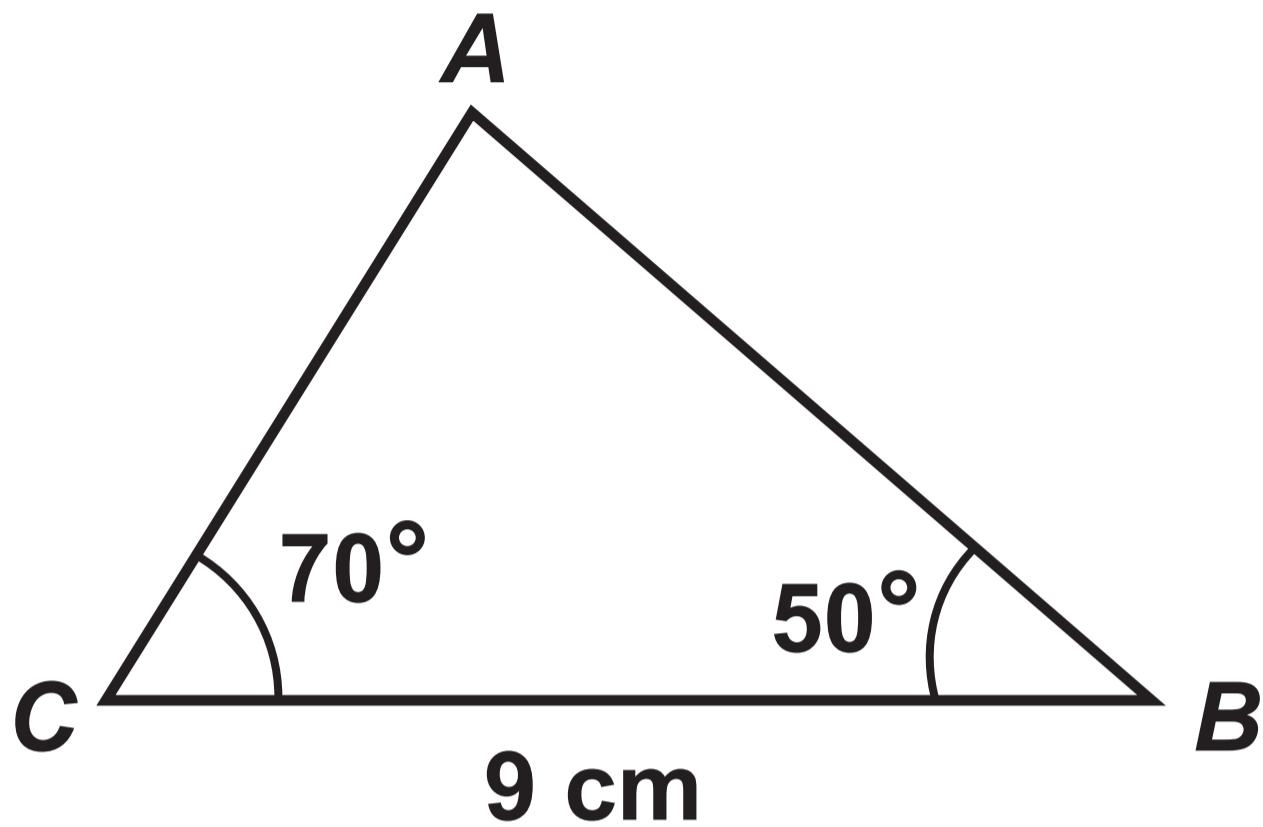

In the space below, make an accurate drawing of triangle ABC shown above.

Question 13

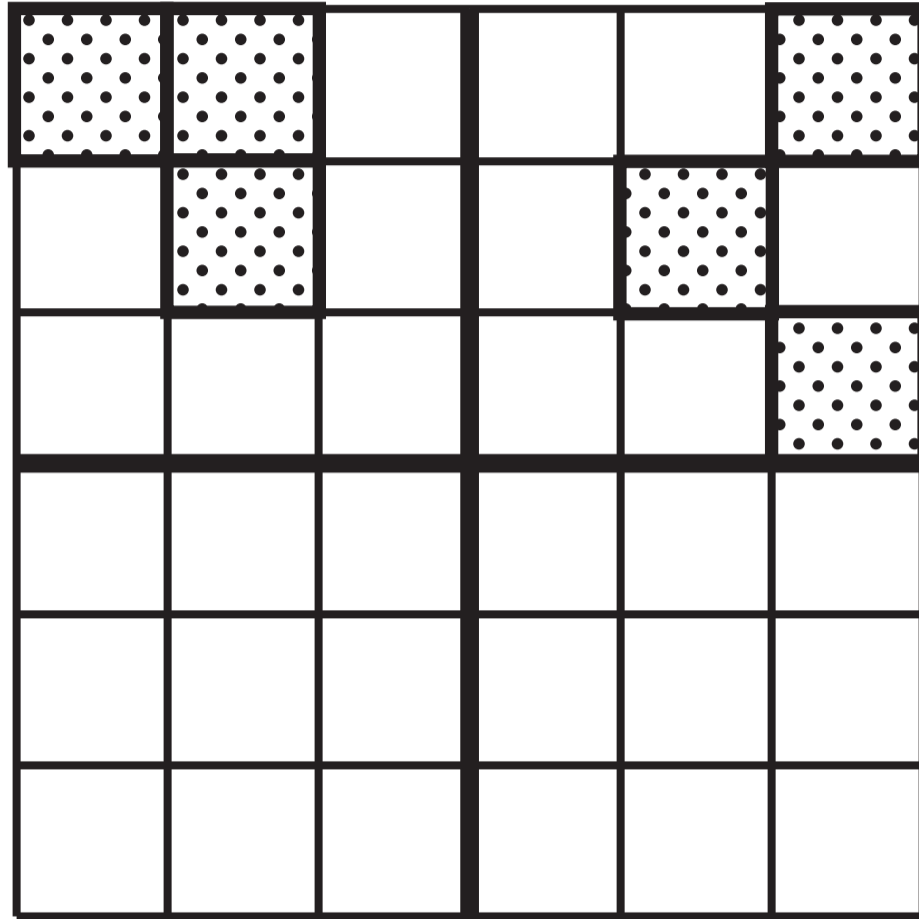

Question 22

Table

Number shown on dice	Frequency
1	65
2	40
3	52
4	10
5	23
6	110

Question 23

Diagram NOT drawn to scale

Rectangle

9 cm

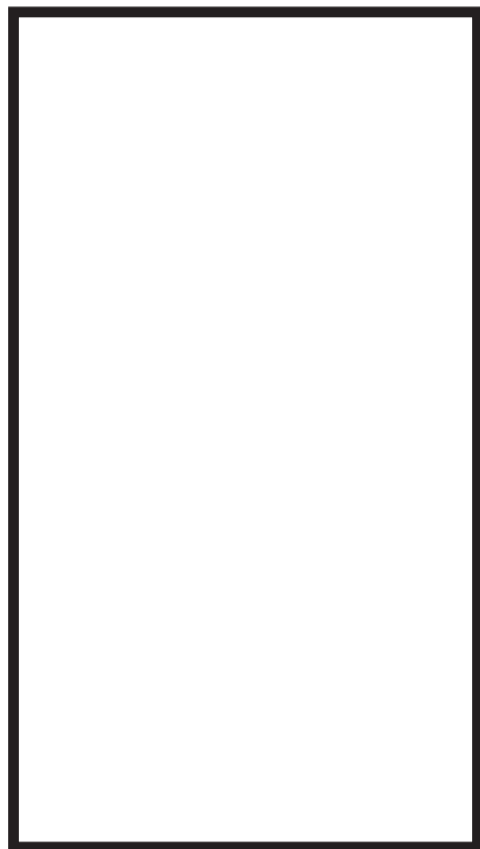

15 cm

Square

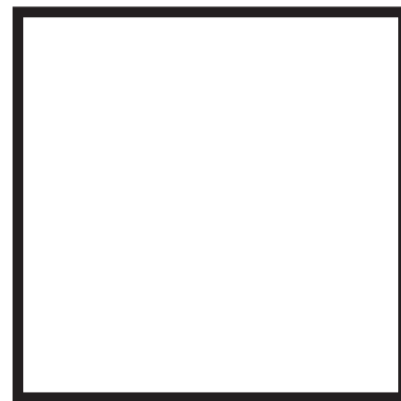

**GCSE
MATHEMATICS
and
NUMERACY**



**FORMULA LIST
FOUNDATION TIER
GCSE**

You must not write on these formula pages.

Anything you write on these formula pages will gain NO credit.

Formula List – Foundation Tier

Area of trapezium $= \frac{1}{2} (a + b) h$

