



**GCSE**

**3310U40 – 1**

**THURSDAY, 7 NOVEMBER 2024 – MORNING**

**MATHEMATICS – NUMERACY  
UNIT 2: CALCULATOR – ALLOWED  
INTERMEDIATE TIER**

**1 hour 45 minutes plus your additional time allowance**

**A CALCULATOR WILL BE REQUIRED FOR THIS PAPER**

**Surname:** \_\_\_\_\_

**First name(s):** \_\_\_\_\_

**Centre Number:** \_\_\_\_\_

**Candidate Number:** 0 \_\_\_\_\_

**For Examiner's use only**

<b>Question</b>	<b>Maximum Mark</b>	<b>Mark Awarded</b>
<b>1.</b>	<b>4</b>	
<b>2.</b>	<b>6</b>	
<b>3.</b>	<b>5</b>	
<b>4.</b>	<b>8</b>	
<b>5.</b>	<b>6</b>	
<b>6.</b>	<b>4</b>	
<b>7.</b>	<b>13</b>	
<b>8.</b>	<b>16</b>	
<b>9.</b>	<b>8</b>	
<b>10.</b>	<b>10</b>	
<b>Total</b>	<b>80</b>	

**ADDITIONAL MATERIALS**

A ruler, protractor and pair of compasses may be required.

**ITEMS INCLUDED WITH QUESTION PAPER**

A separate Formula List.

A separate Diagram Booklet.

Models for Question 4.

**The Diagram Booklet MUST be handed in to the invigilators and sent for marking.**

**INSTRUCTIONS TO CANDIDATES**

Use black ink, black ball – point pen, black felt tip or your usual method.

Write your name, centre number and candidate number in the spaces on the front cover.

Answer ALL questions.

Write your answers in the spaces provided. If you run out of space, use the additional page(s) at the back of this booklet, taking care to number the question(s) correctly.

Take  $\pi$  as  $3 \cdot 14$  or use the  $\pi$  button on your calculator.

(Turn over)

**INFORMATION FOR CANDIDATES**

**You should give details of your method of solution when appropriate.**

**Unless stated, diagrams are not drawn to scale.**

**Scale drawing solutions will not be acceptable where you are asked to calculate.**

**The number of marks is given in brackets at the end of each question or part – question.**

**In question 5, the assessment will take into account the quality of your linguistic and mathematical organisation, communication and accuracy in writing.**

1. Look at the diagram for Question 1 in the separate Diagram Booklet. The diagram shows a graph. Yesterday, Jemila cycled along a straight track from home to the beach and back.

- (a) For how many minutes was Jemila  $17.5$  km from home?

\_\_\_\_\_ minutes

[1 mark]

- (b) At what time did Jemila first start cycling in the direction of home?

Circle your answer.

13:30	14:15	15:00	15:30	16:00
-------	-------	-------	-------	-------

[1 mark]

continued on the next page . . .

(Turn over)

**Question 1 continued**

**1. (c) By 15:30, how many kilometres in total had Jemila cycled?**

---

---

---

\_\_\_\_\_ km

**[1 mark]**

**(d) Jemila was due to get home at 16:30  
She arrived home early.  
Approximately how many minutes early  
was she?**

---

---

---

\_\_\_\_\_ minutes

**[1 mark]**

2. (a) Lewis buys an annual discount card to use in a sports shop.

He pays **£9.95** for the discount card.

For one year, Lewis gets **15%** off anything he buys in this sports shop when he shows his discount card.

During the year, Lewis buys the following three items.

<b>Full price BEFORE discount</b>		
<b>Trainers</b> <b>£55</b>	<b>Tennis racket</b> <b>£18</b>	<b>T – shirt</b> <b>£12</b>

How much did Lewis save during the year by using his discount card?

Remember that Lewis had to buy his discount card.

You must show all your working.

---

---

---

---

(Turn over)

---

---

---

---

**[4 marks]**

**continued on the next page . . .**

**(Turn over)**

**Question 2 continued**

2. (b) Sally buys clothes from the same sports shop.  
She does not have a discount card.

In a sale, there is  $\frac{1}{6}$  off the full price of a hoodie.

On the last day of the sale, customers could buy the hoodie for half of the sale price.

Sally buys the hoodie on the last day of the sale.  
What fraction of the original full price of the hoodie does Sally pay?

---

---

---

---

---

---

---

**[2 marks]**

**(Turn over)**

3. Look at the diagram for Question 3 in the separate Diagram Booklet. The diagram is a Venn diagram. A music teacher asked all Year 7 students to choose which musical instruments they would like to be able to play.

They could choose from three instruments: guitar, drums and violin.

The students could choose as many of these instruments as they wished.

The Venn diagram shows the results.

- (a) How many students did not choose an instrument?

\_\_\_\_\_ students

[1 mark]

- (b) How many students chose all 3 instruments?

\_\_\_\_\_ students

[1 mark]

continued on the next page . . .

(Turn over)

**Question 3 continued**

**3. (c) How many Year 7 students were there?**

---

---

---

\_\_\_\_\_ **students**

**[1 mark]**

**(d) How many students chose 2 or more instruments?**

---

---

---

\_\_\_\_\_ **students**

**[1 mark]**

**(e) Which was the least popular instrument?  
How many students chose this instrument?**

---

---

---

**Least popular instrument** \_\_\_\_\_

**Number of students** \_\_\_\_\_

**[1 mark]**

**(Turn over)**

4. Ask for the models for Question 4. The models are NOT made to scale.

PressiePacs is a company that designs and makes presentation boxes.

- (a) The models represent two designs, small and large.

The small presentation box has the following dimensions:

Length = 10 cm

Width = 10 cm

Height = 10 cm

The large presentation box has the following dimensions:

Length = 12.5 cm

Width = 12.5 cm

PressiePacs wants the large box to have TWICE the volume of the small box.

Calculate the height of the large box.

---

---

---

---

---

---

---

---

**[5 marks]**

**continued on the next page . . .**

**(Turn over)**

**Question 4 continued**

4. (b) Customers can use this formula to calculate the cost of a presentation box:

$$\text{Cost in } \pounds = \text{Surface area of the box in cm}^2 \div 240$$

**Remember: The small presentation box has the following dimensions:**

**Length = 10 cm**

**Width = 10 cm**

**Height = 10 cm**

**Calculate the cost of the SMALL presentation box.**

---

---

---

---

---

---

---

---

**Cost of the small presentation box**

**is £ \_\_\_\_\_**

**[3 marks]**

**(Turn over)**

5. IN THIS QUESTION, YOU WILL BE ASSESSED ON THE QUALITY OF YOUR ORGANISATION, COMMUNICATION AND ACCURACY IN WRITING.

Look at the diagram for Question 5 in the separate Diagram Booklet. The diagram is a pie chart.

72 000 people were asked to state their main way of travelling to work.

The results are shown accurately in the pie chart.

The people who said 'Public transport' travel to work EITHER by bus OR by train.

For every person who travels to work by bus, there are 4 people who travel by train.

Calculate the number of people who travel to work by TRAIN.

You must show all your working.

---

---

---

---

---

---

---

---

---

---

---

---

---

---

---

**[4 marks + 2 marks OCW]**

6. Look at the diagram for Question 6 in the separate Diagram Booklet. The diagram is NOT drawn to scale. The diagram shows a plan of a floor labelled ***ABC***.

In the diagram:

$$AC = 2.7 \text{ metres}$$

$$CB = 4.3 \text{ metres}$$

Angle ***ACB*** is a right angle

Alfred has been given the job of varnishing the floor.

One tin of varnish contains enough to cover an area of  $1.6 \text{ m}^2$

Alfred says,

**“I only need 3 tins of varnish to do this job.”**

Is Alfred correct?

Yes       No

You must show all your working.

---

---

(Turn over)

---

---

---

---

---

---

---

---

---

**[4 marks]**



---

---

---

---

---

---

---

**[5 marks]**

**continued on the next page . . .**

**(Turn over)**



**Question 7 continued**

7. (c) Look at the diagram for Question 7 (c) in the separate Diagram Booklet. The diagram is NOT drawn to scale. The diagram represents a fridge – freezer.

Steffan is thinking of buying the fridge – freezer shown in the diagram.

The width is **600 mm**.

The height is **1800 mm**.

Steffan needs to check that the **FREEZER** compartment of this fridge – freezer has enough room.

The height of the freezer door is  $\frac{2}{5}$  of the total height of the fridge – freezer.

Calculate the length of the **DIAGONAL** of the freezer door.

Give your answer in millimetres.

You must show all your working.

---

---

---

---

---

---

---

---

---

**[5 marks]**

**(Turn over)**

8. (a) A small packet contains four Caru chocolate cakes.

The four cakes have a total mass of **84 g**.

- (i) The following information is written on the packet:

**‘Caru chocolate cakes contain 600 calories per 100 g.’**

Simon aims for a calorie intake of **2400 calories** per day.

Today Simon eats **ONE** Caru chocolate cake.  
What percentage of his daily calorie intake is this cake?

You must show all your working.

---

---

---

---

---

---

---

---

---

---

---

---

---

---

---

**[5 marks]**

**continued on the next page . . .**

**Question 8 (a) continued**

- 8. (a) (ii) Caru chocolate cakes contain only fat, carbohydrate, protein and salt.**

**Look at the information for Question 8 (a) (ii) in the separate Diagram Booklet.**

**The information shows a ratio.**

**How many grams of protein are there in an 84 g packet of four cakes?**

**Give your answer correct to 2 significant figures.**

---

---

---

---

---

---

---

---

---

---

**[3 marks]**

**continued on the next page . . .**

**(Turn over)**

**Question 8 continued**

8. (b) Cheryl keeps fit by running every day.

- (i) Cheryl has a mass of **143 pounds**.  
What is Cheryl's mass in **kg**?

---

---

---

---

\_\_\_\_\_ kg

**[2 marks]**

**continued on the next page . . .**

**(Turn over)**



**Question 8 (b) continued**

**8. (b) (iii) Cheryl runs at an average speed of 9 km per hour.**

**Yesterday morning she ran for 38 minutes.**

**Calculate the distance Cheryl ran yesterday morning.**

---

---

---

---

---

---

---

---

\_\_\_\_\_ km

**[3 marks]**

**(Turn over)**

9. (a) Look at the diagram for Question 9 (a) in the separate Diagram Booklet. The diagram is NOT drawn to scale.

The base of a flagpole is fixed to horizontal ground.

It is held vertically by a straight rod of length  $3.8$  metres.

The rod is fixed to the ground and to a point  $1.5$  metres from the top of the flagpole.

The flagpole and the rod are shown in the diagram.

Calculate the TOTAL height of the flagpole.

Give your answer correct to the nearest centimetre.

---

---

---

---

---

---

---

---

---

---

---

---

**[4 marks]**

**continued on the next page . . .**

**(Turn over)**

**Question 9 continued**

9. (b) Look at the diagrams for Question 9 (b) in the separate Diagram Booklet. The diagrams are NOT drawn to scale.

Mathematically similar large, medium and small flags are shown.

- (i) Calculate the length of the medium flag.

---

---

---

---

---

---

---

Length of the medium flag is \_\_\_\_\_ cm  
[2 marks]

continued on the next page . . .

(Turn over)

Question 9 (b) continued

9. (b) (ii) Calculate the height of the small flag.

---

---

---

---

---

---

---

Height of the small flag is \_\_\_\_\_ cm  
[2 marks]

**10. Aderyn is a company that makes bird feeders.**

**Squirrels often try to steal food from bird feeders.**

**To make this more difficult, Aderyn has designed a NEW bird feeder.**

**Aderyn tests its new feeder to check how long it takes squirrels to reach the food inside.**

**Look at the diagram for Question 10 in the separate Diagram Booklet. The diagram is a cumulative frequency diagram.**

**The results are displayed in this cumulative frequency diagram.**

**continued on the next page . . .**

**Question 10 continued**

**10. (a) Look at the table for Question 10 (a) in the separate Diagram Booklet. Aderyn has this information about the time it took squirrels to reach the food in its ORIGINAL bird feeder.**

**Aderyn compared the times squirrels take to reach the food in the original bird feeder and the times they take to reach food in the new bird feeder.**

**(i) Complete this sentence:**

**‘The modal group for the new bird feeder is between \_\_\_\_\_ and \_\_\_\_\_ seconds.’**

**Does the modal group for the new bird feeder imply that there is an improvement in the times?**

**Yes**  **No**

**[1 mark]**

**continued on the next page . . .**

**(Turn over)**

**Question 10 (a) (i) continued**

**10. (a) (ii) Use the cumulative frequency diagram and the table for Question 10 in the Diagram Booklet to give the best estimate to complete each of the following sentences.**

- I. 'The difference between the median times is \_\_\_\_\_ seconds.'**

---

---

**[1 mark]**

- II. 'The difference between the interquartile ranges of the times is \_\_\_\_\_ seconds.'**

---

---

---

---

---

**[2 marks]**

**continued on the next page . . .**

**(Turn over)**

**Question 10 continued**

**10. (b) Use the cumulative frequency diagram for Question 10 in the Diagram Booklet to give the best estimate to complete the following sentence.**

**‘20% of the squirrels took  
\_\_\_\_\_ seconds or more to  
reach the food in the new bird feeder.’**

---

---

---

---

---

**[3 marks]**

**continued on the next page . . .**

**(Turn over)**

**Question 10 continued**

- 10. (c) The population density of grey squirrels in forests depends on the variety of tree that grows there.**

**Look at the table for Question 10 (c) in the separate Diagram Booklet.**

**Rhian says,**

**“I know that Maesgwyn forest has only one variety of tree: oak, chestnut or pine.”**

**continued on the next page . . .**

**(Turn over)**

**Question 10 (c) continued**

**Maesgwyn forest covers an area of 21 500 m<sup>2</sup>  
There are 24 grey squirrels living in  
Maesgwyn forest.**

**From this information, which variety of tree is  
most likely to be found in Maesgwyn forest?**

**You must show working to support your answer.**

**Oak**

**Chestnut**

**Pine**

---

---

---

---

---

---

---

---

**(Turn over)**

---

---

---

---

---

---

---

---

**[3 marks]**

---

**END OF PAPER**

**TOTAL 80 MARKS**

---

**(Turn over)**









**GCSE**

**3310U40-1**

**THURSDAY, 7 NOVEMBER 2024 – MORNING**

**MATHEMATICS – NUMERACY**

**UNIT 2: CALCULATOR – ALLOWED**

**INTERMEDIATE TIER**

**The Diagram Booklet MUST be handed in  
to the invigilators and sent for marking.**

# **Diagram Booklet**

**Surname:** \_\_\_\_\_

**First name(s):** \_\_\_\_\_

**Centre Number:** \_\_\_\_\_

**Candidate Number:** 0 \_\_\_\_\_

# Question 1

Distance from home (km)

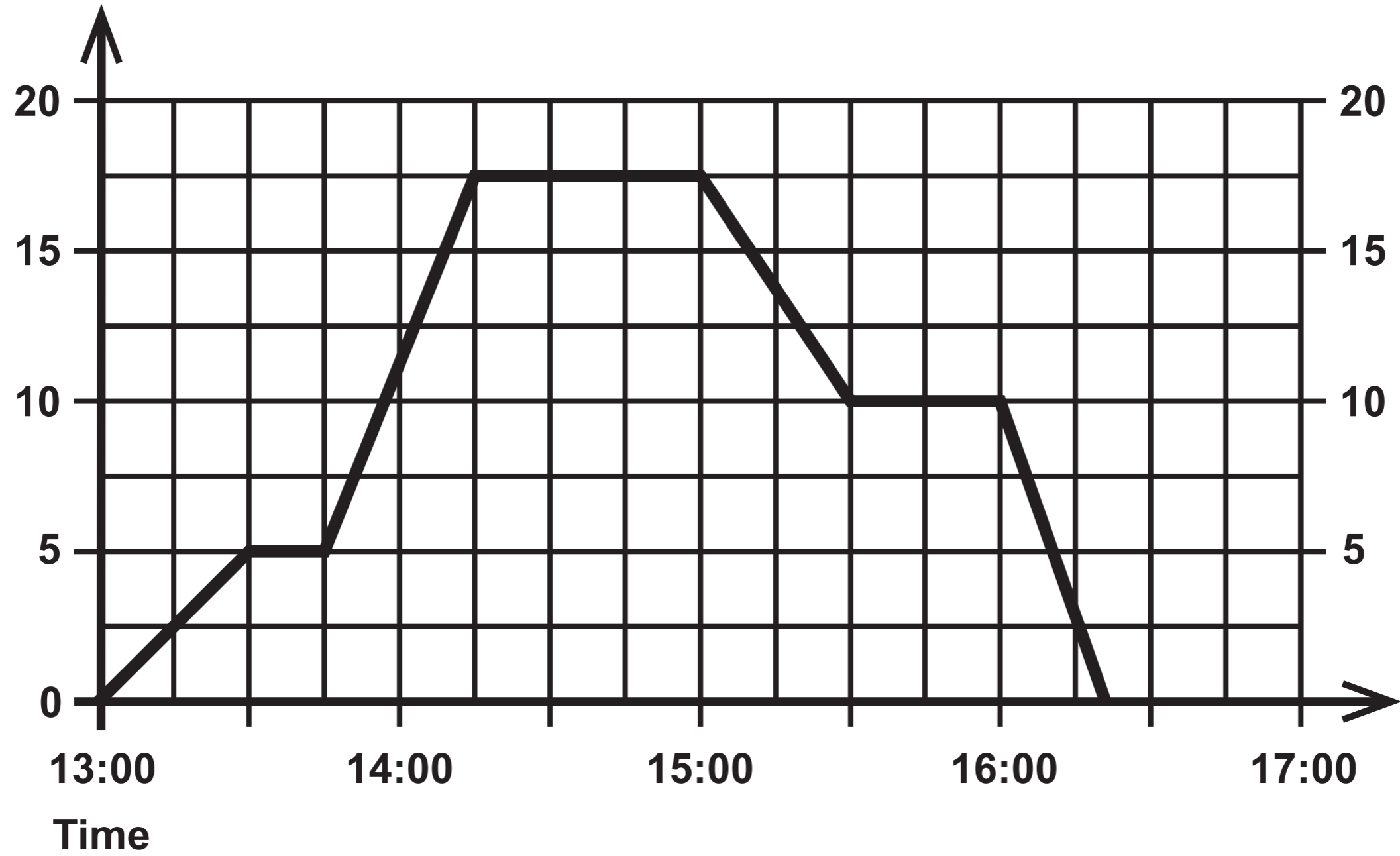

### Question 3

3

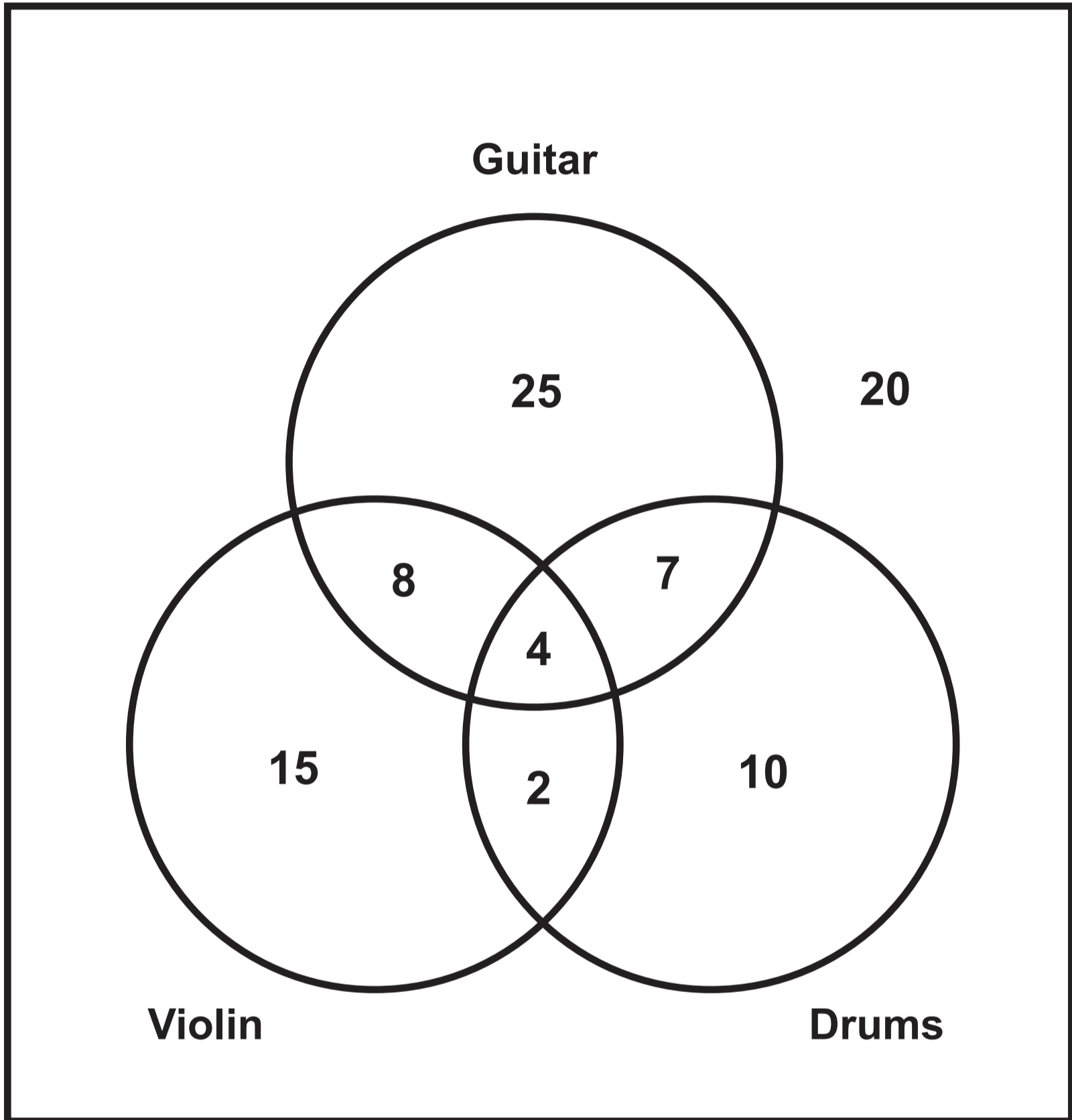

### Question 5

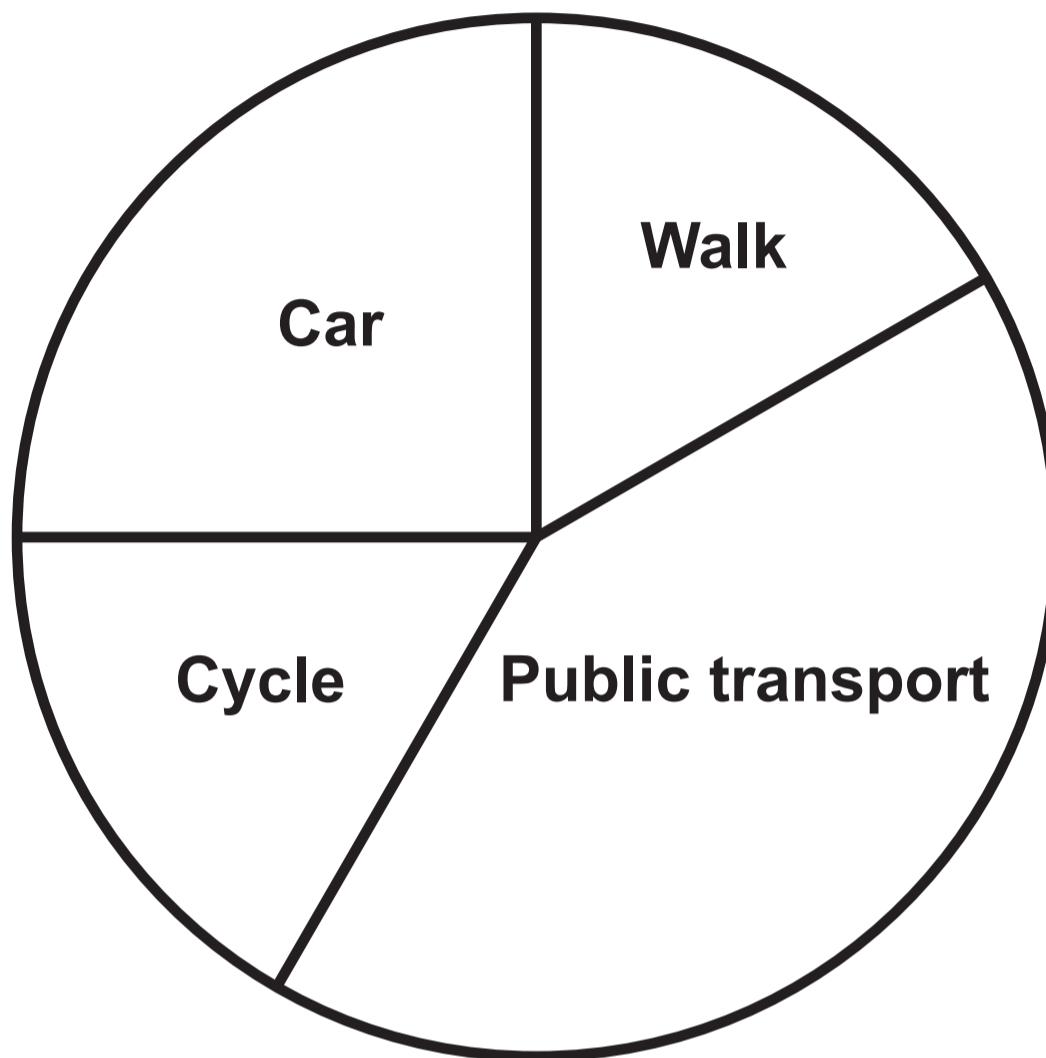

### Question 6

Diagram NOT drawn to scale

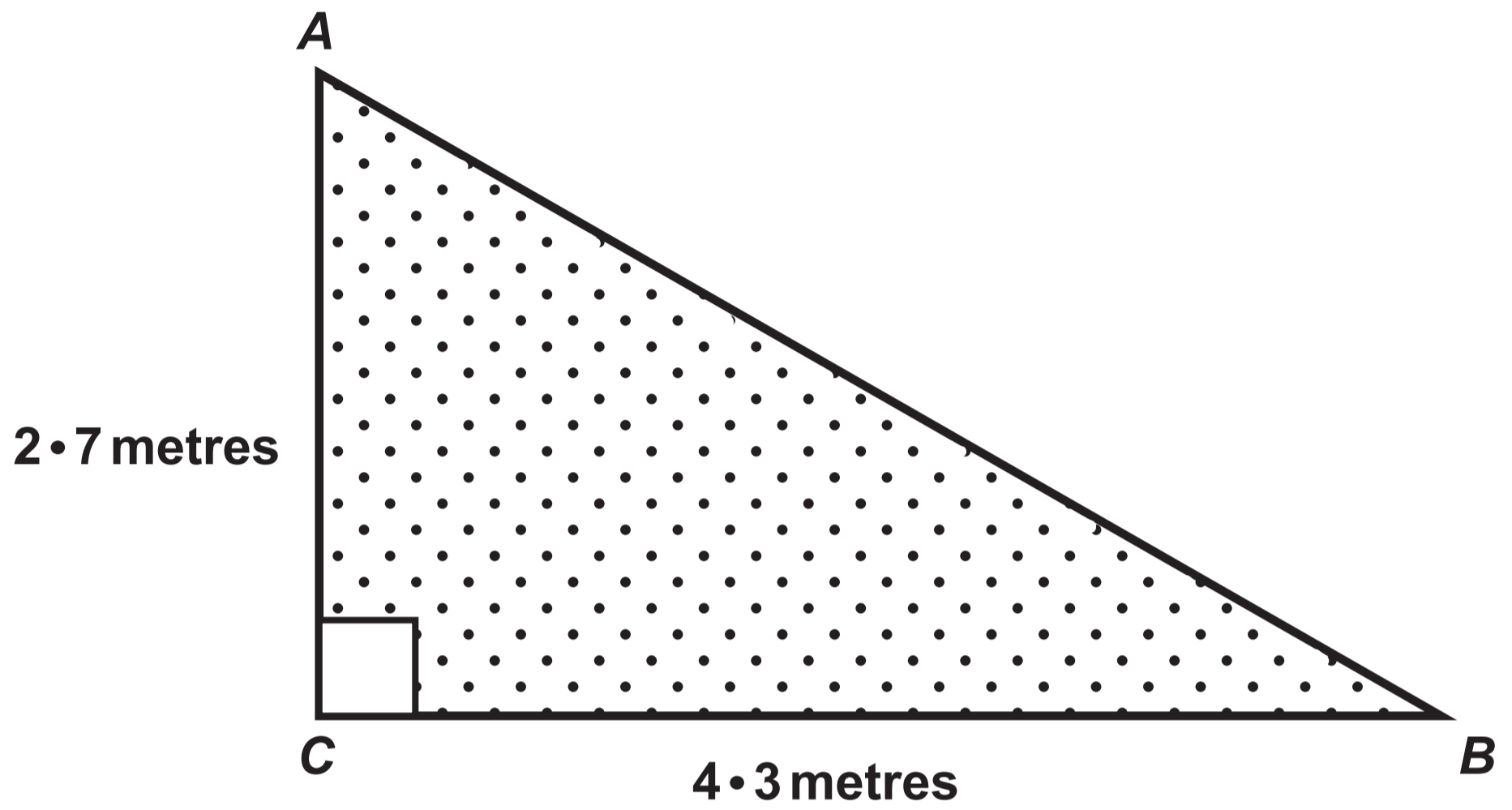

**Question 7 (c)**

**Diagram NOT drawn to scale**

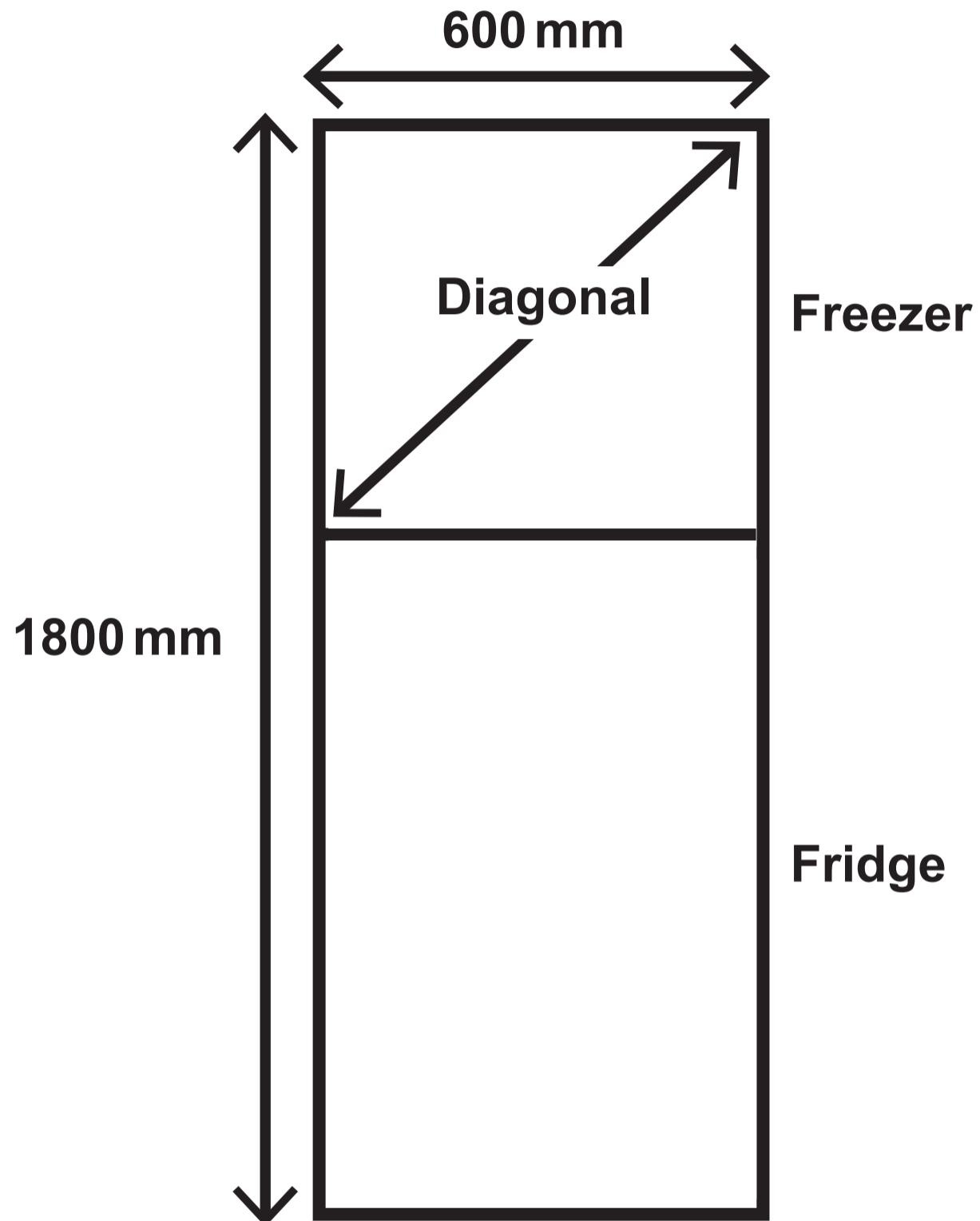

## Question 8 (a) (ii)

The ratio of the masses is

fat : carbohydrate : protein : salt = 1360 : 2725 : 515 : 4

**Question 9 (a)**

**Diagram NOT drawn to scale**

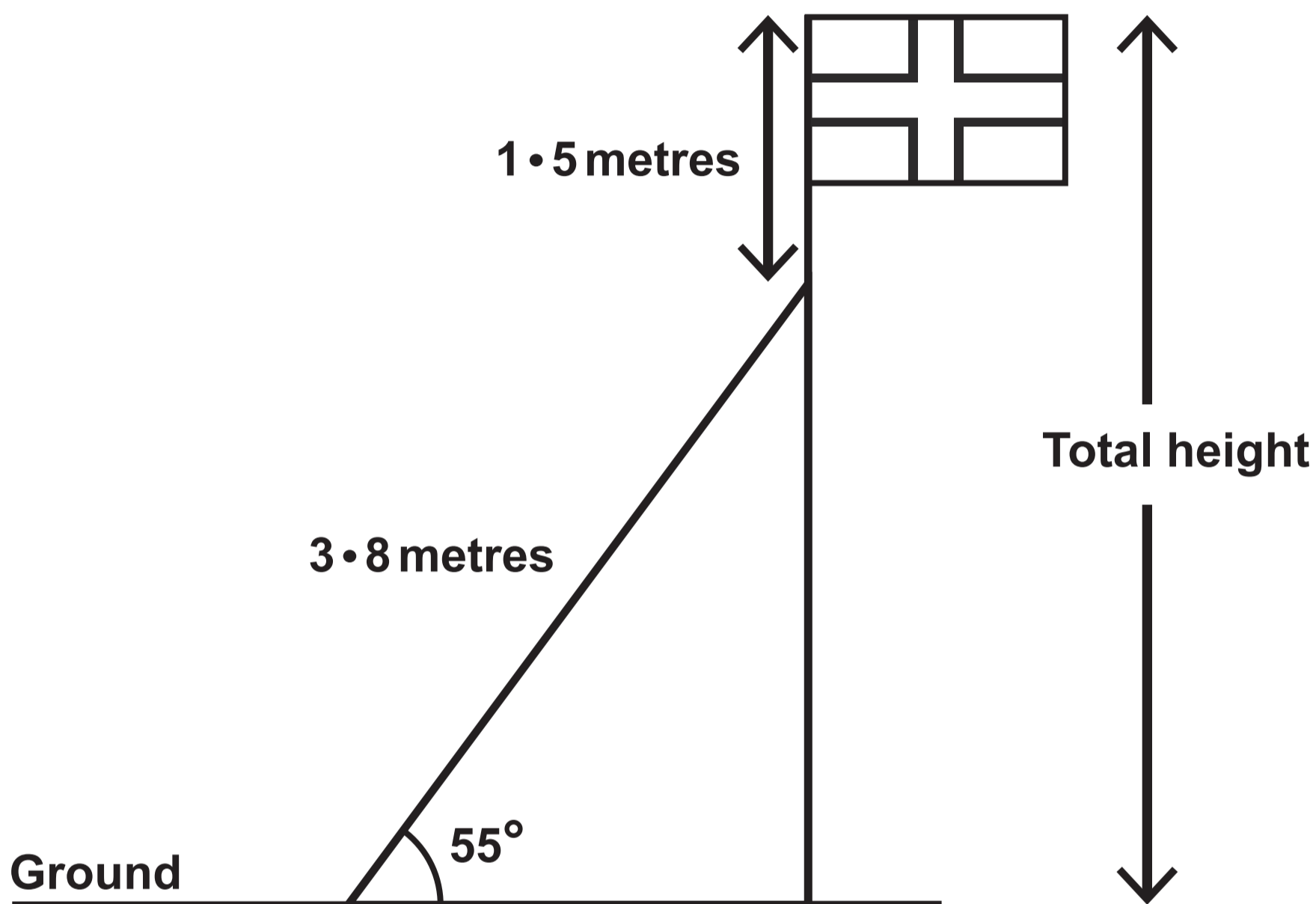

**Question 9 (b)**

**Diagrams NOT drawn to scale**

**Large flag**

**120 cm**

**80 cm**

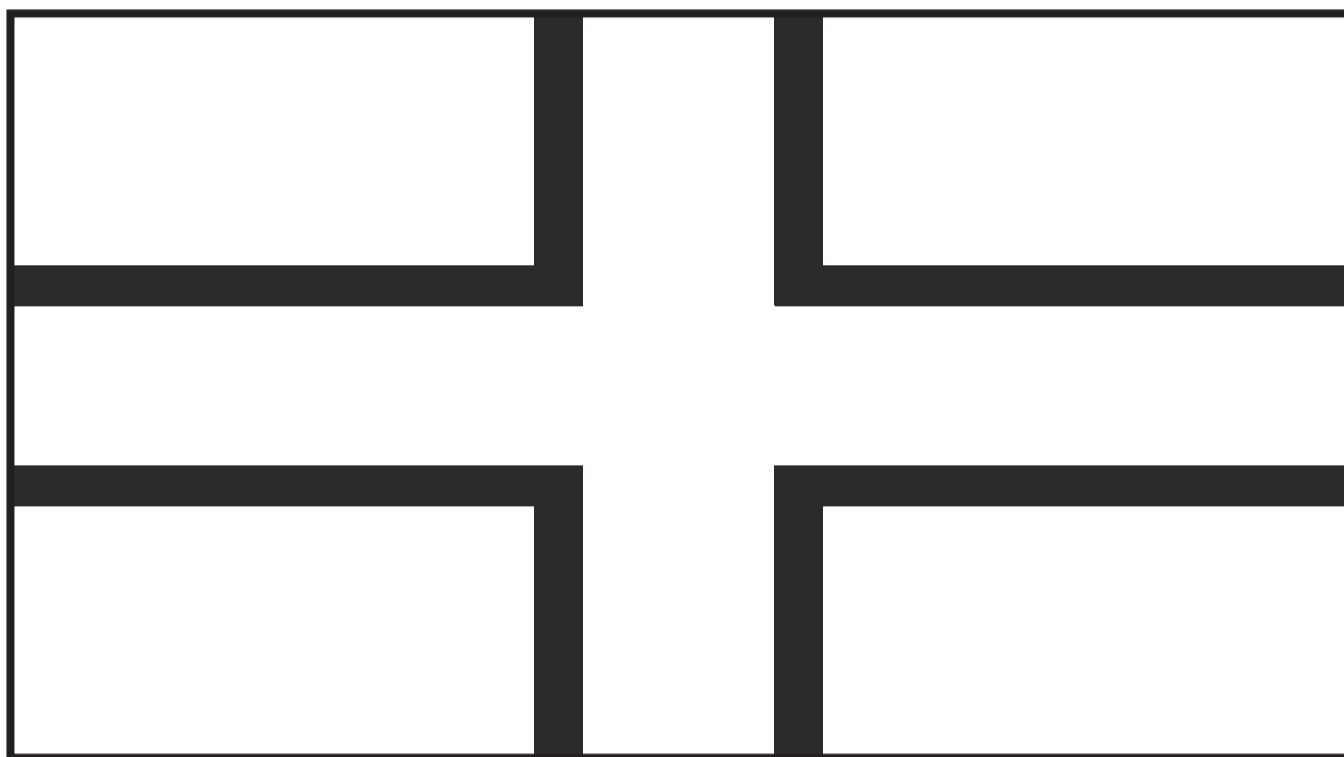

**Medium flag**

**Length**

**64 cm**

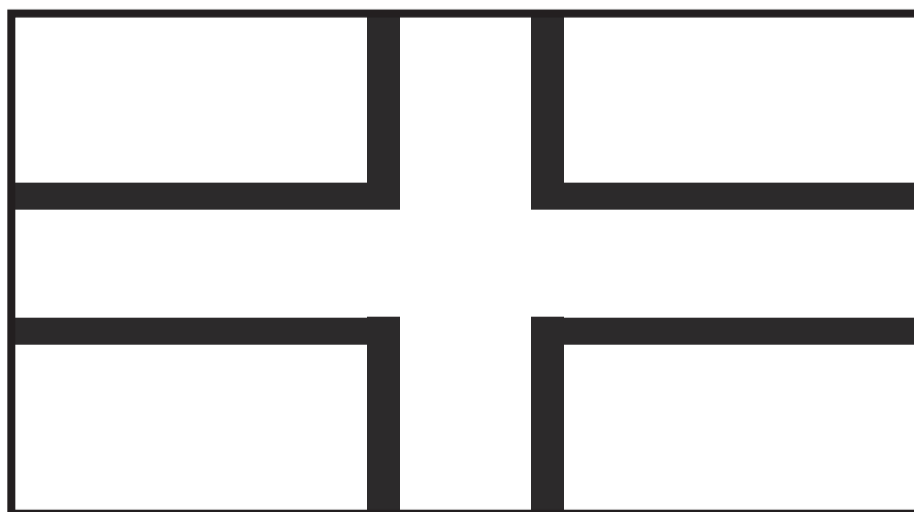

**Small flag**

**75 cm**

**Height**

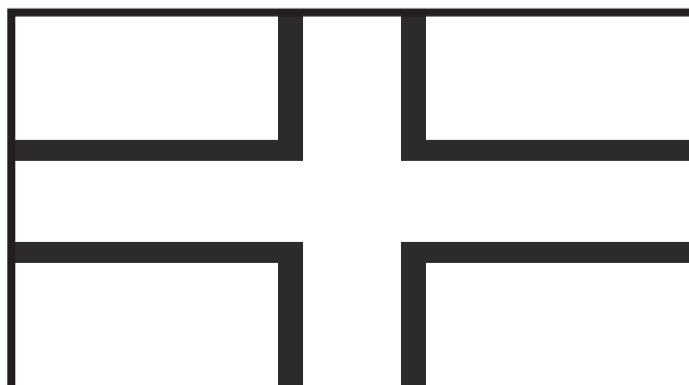

# Question 10

## NEW bird feeder

Cumulative frequency

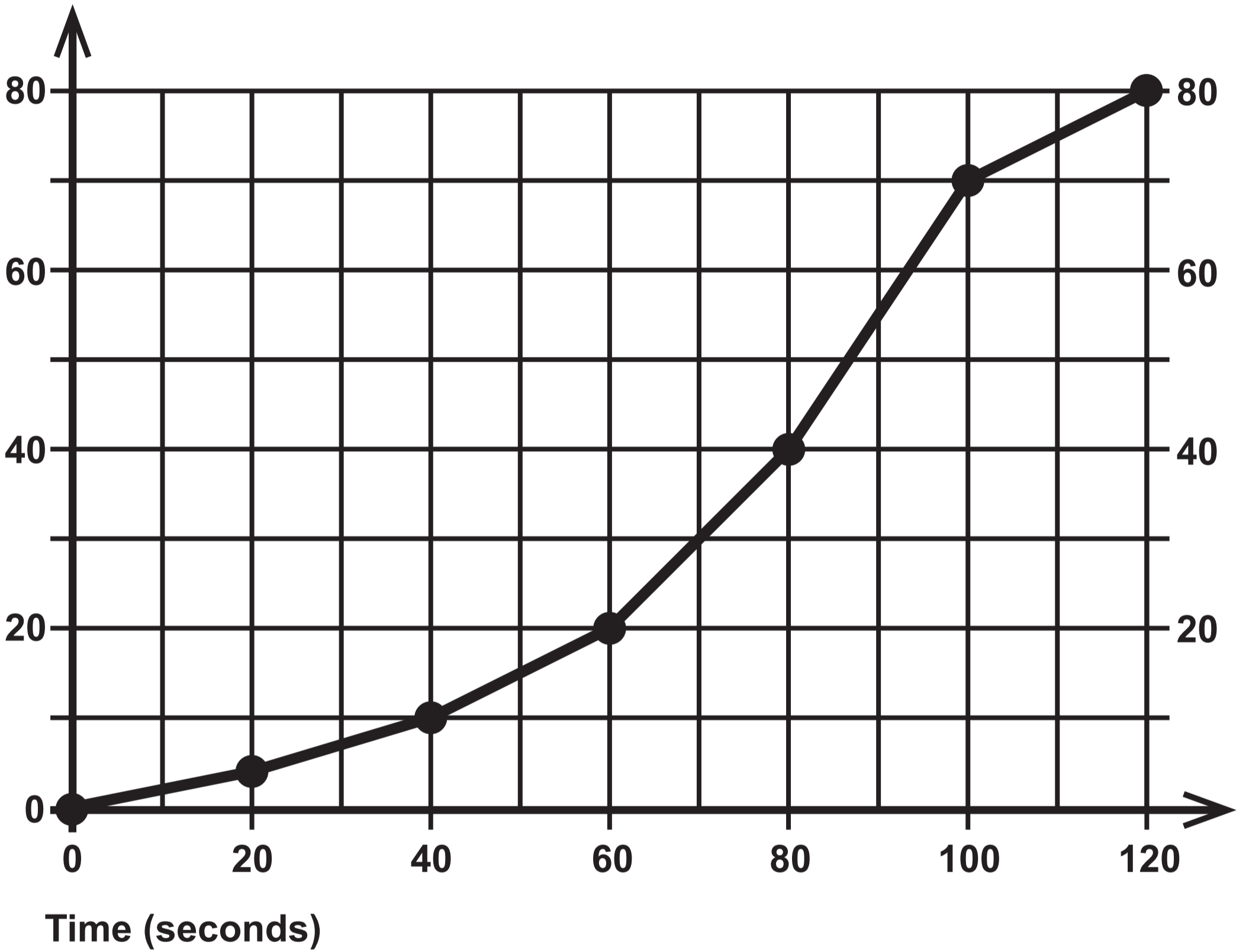

### Question 10 (a)

<b>ORIGINAL bird feeder</b>	
<b>Modal group</b>	<b>60 to 80 seconds</b>
<b>Median time</b>	<b>75 seconds</b>
<b>Interquartile range</b>	<b>20 seconds</b>

### Question 10 (c)

<b>Variety of tree</b>	<b>Typical population density of grey squirrels PER km<sup>2</sup></b>
<b>Oak</b>	<b>1200</b>
<b>Chestnut</b>	<b>100</b>
<b>Pine</b>	<b>45</b>

**GCSE  
MATHEMATICS  
and  
GCSE  
MATHEMATICS – NUMERACY**

**FORMULA LIST  
INTERMEDIATE TIER  
GCSE**

**You must not write on these formula pages.**

**Anything you write on these formula pages will gain NO credit.**

## Formula List – Intermediate Tier

Area of trapezium  $= \frac{1}{2} (a + b) h$

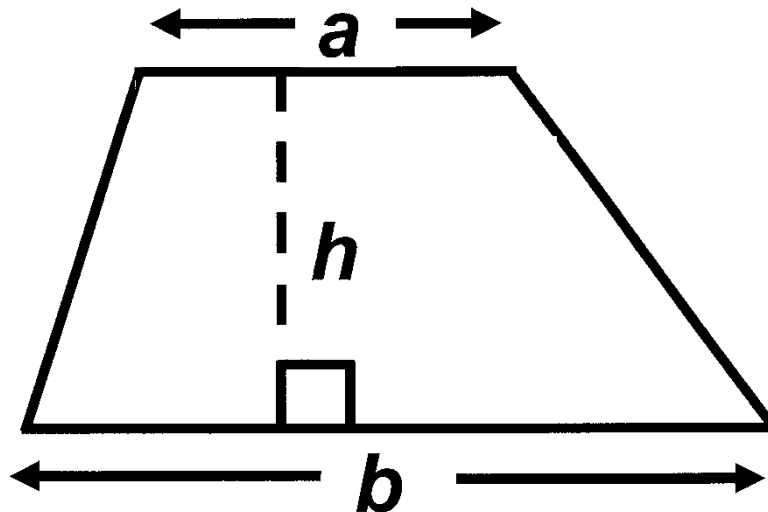

Volume of prism =  
area of cross – section  $\times$  length

