



GCE A LEVEL

1300U40-1

TUESDAY, 13 JUNE 2023 – AFTERNOON

MATHEMATICS – A2 unit 4

APPLIED MATHEMATICS B

1 hour 45 minutes plus your additional time allowance

ADDITIONAL MATERIALS

In addition to this examination paper, you will need:

- a WJEC pink 16-page answer booklet;
- a Formula Booklet;
- a calculator;
- statistical tables (RND/WJEC Publications).

INSTRUCTIONS TO CANDIDATES

Use black ink, black ball-point pen or your usual method.

Answer ALL questions.

Write your answers in the separate answer booklet provided, following the instructions on the front of the answer booklet.

Use both sides of the paper. Please only write within the white areas of the booklet.

Write the question number in the left hand margin at the start of each answer. Write the sub parts, e.g. a, b and c, within the white areas of the booklet.

(Turn over)

Leave at least two line spaces between each answer.

Take g as 9.8 ms^{-2}

Sufficient working must be shown to demonstrate the MATHEMATICAL method employed.

Answers without working may not gain full credit.

Unless the degree of accuracy is stated in the question, answers should be rounded appropriately.

INFORMATION FOR CANDIDATES

The maximum mark for this paper is 80.

The number of marks is given in brackets at the end of each question or part-question.

You are reminded of the necessity for good English and orderly presentation in your answers.

(Turn over)

ADDITIONAL FORMULAE FOR 2023**LAWS OF LOGARITHMS**

$$\log_a x + \log_a y \equiv \log_a (xy)$$

$$\log_a x - \log_a y \equiv \log_a \left(\frac{x}{y} \right)$$

$$k \log_a x \equiv \log_a (x^k)$$

SEQUENCES

General term of an arithmetic progression:

$$u_n = a + (n - 1) d$$

General term of a geometric progression:

$$u_n = ar^{n-1}$$

(Turn over)

MENSURATION

For a circle of radius, r , where an angle at the centre of θ radians subtends an arc of length S and encloses an associated sector of area A :

$$s = r\theta$$

$$A = \frac{1}{2} r^2 \theta$$

CALCULUS AND DIFFERENTIAL EQUATIONS**DIFFERENTIATION****FUNCTION****DERIVATIVE**

$$f(x)g(x)$$

$$f'(x)g(x) + f(x)g'(x)$$

$$f(g(x))$$

$$f'(g(x))g'(x)$$

INTEGRATION**FUNCTION****INTEGRAL**

$$f'(g(x))g'(x)$$

$$f(g(x)) + c$$

$$\text{Area under a curve} = \int_a^b y dx$$

(Turn over)

REMINDER: Sufficient working must be shown to demonstrate the MATHEMATICAL method employed.

SECTION A: STATISTICS

01. Two fair, non-cubical dice give scores of **1** to **4** and **1** to **8** respectively. A dice is selected at random and then rolled once.
- (a) Find the probability that the score is less than **4**
[3 marks]
- (b) Draw a Venn diagram with the events “Score less than **8**” and “Score less than **4**”
Include the probability for each distinct region on your diagram. [3 marks]

	GIVEN THAT THE TREE HAS		
	TYPE X	TYPE Y	NO FUNGUS
PROBABILITY OF A POSITIVE TEST RESULT	0.95	d	0.02
PROBABILITY OF A NEGATIVE TEST RESULT	0.05	$1 - d$	0.98

02. A certain fungus occurs in a population of trees in two mutually exclusive types, X and Y

It is known that 4% of the trees have type X of the fungus and there is an unknown proportion, p , of trees that have type Y of the fungus.

A tree surgeon has developed a test to help diagnose whether or not a tree has the fungus. Information collected during the research process is given in the table opposite.

The tree surgeon calculates that, for a randomly selected tree from the population,

- the probability of the tree testing positive for the fungus is 0.122
- the probability of the tree not having the fungus, given that it tests positive, is $\frac{87}{610}$

Show that the value of p is 0.09 and find the value of d [7 marks]

(Turn over)

03. The continuous random variable X is uniformly distributed over the interval $[1, d]$

(a) The **90th** percentile of X is **19**

Find the value of d

[3 marks]

(b) Calculate the mean and standard deviation of X

[2 marks]

04. A bakery produces large loaves with masses, in grams, that are normally distributed with mean μ and variance σ^2

It is found that **11%** of the large loaves weigh more than **805 g** and that **20%** of the large loaves weigh less than **795 g**

- (a) Find the values of μ and σ [8 marks]

The bakery also produces small loaves with masses, in grams, that are normally distributed with mean **400** and standard deviation **9**

Following a change of management at the bakery, a customer suspects that the mean mass of the small loaves has decreased. The customer weighs the next **15** small loaves that he purchases and calculates their mean mass to be **397 g**

- (b) Perform a hypothesis test at the **5%** significance level to investigate the customer's suspicion, assuming the standard deviation, in grams, is still **9** [6 marks]

- (c) State another assumption you have made in part (b). [1 mark]

(Turn over)

SUGAR CONSUMPTION AND RATE OF DISEASE

Percentage of population with the disease

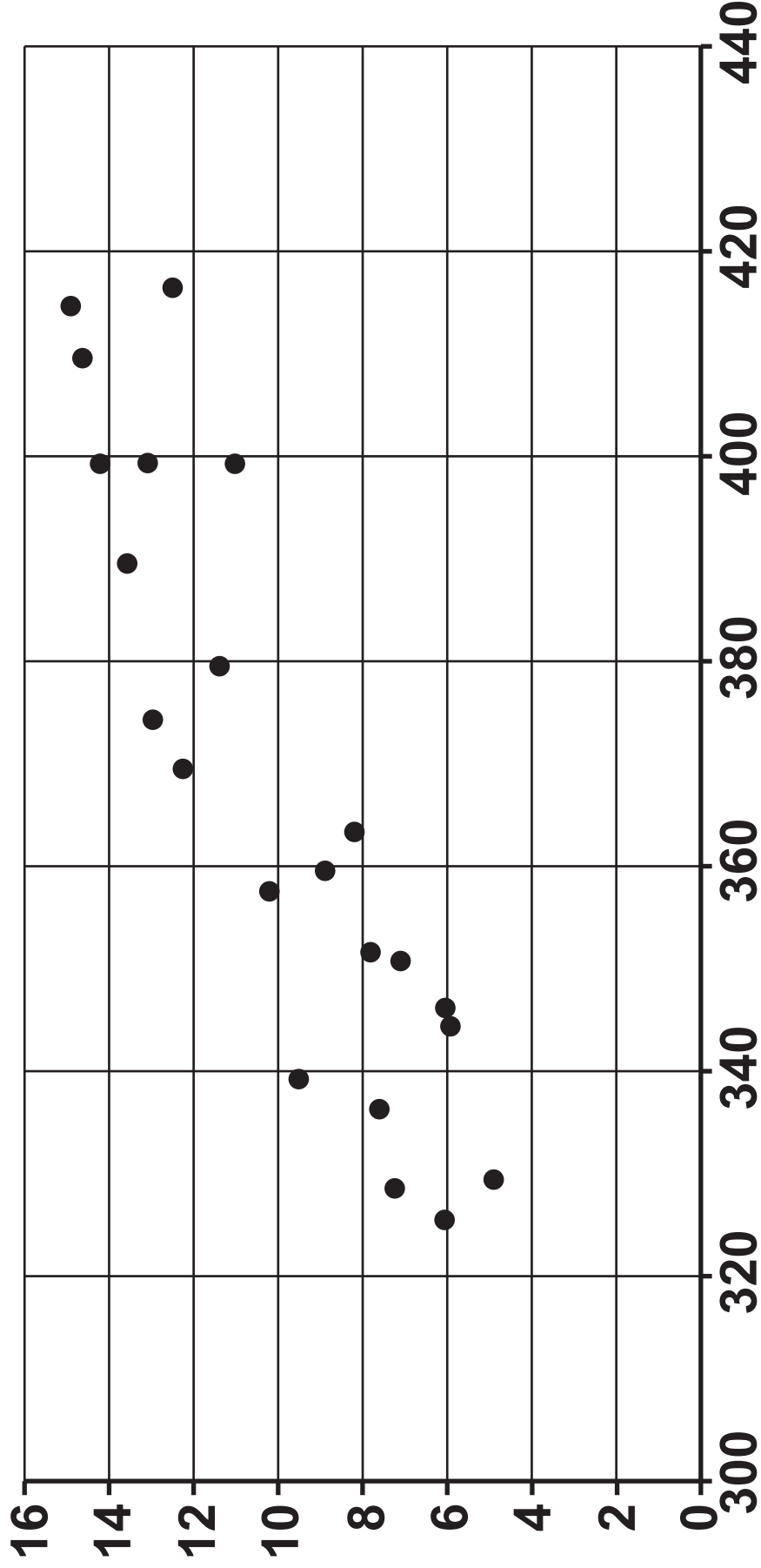

Per capita daily calories from sugar consumption

05. A medical researcher is investigating possible links between diet and a particular disease. She selects a random sample of **22** countries and records the average daily calorie intake per capita from sugar and the percentage of the population who suffer from this disease, as shown in the graph opposite.

There are **22** data points and the product moment correlation coefficient is **0.893**

- (a) Stating your hypotheses clearly, show that these data could be used to suggest that there is a link between the disease and sugar consumption.

[5 marks]

SUGAR CONSUMPTION AND RATE OF DISEASE

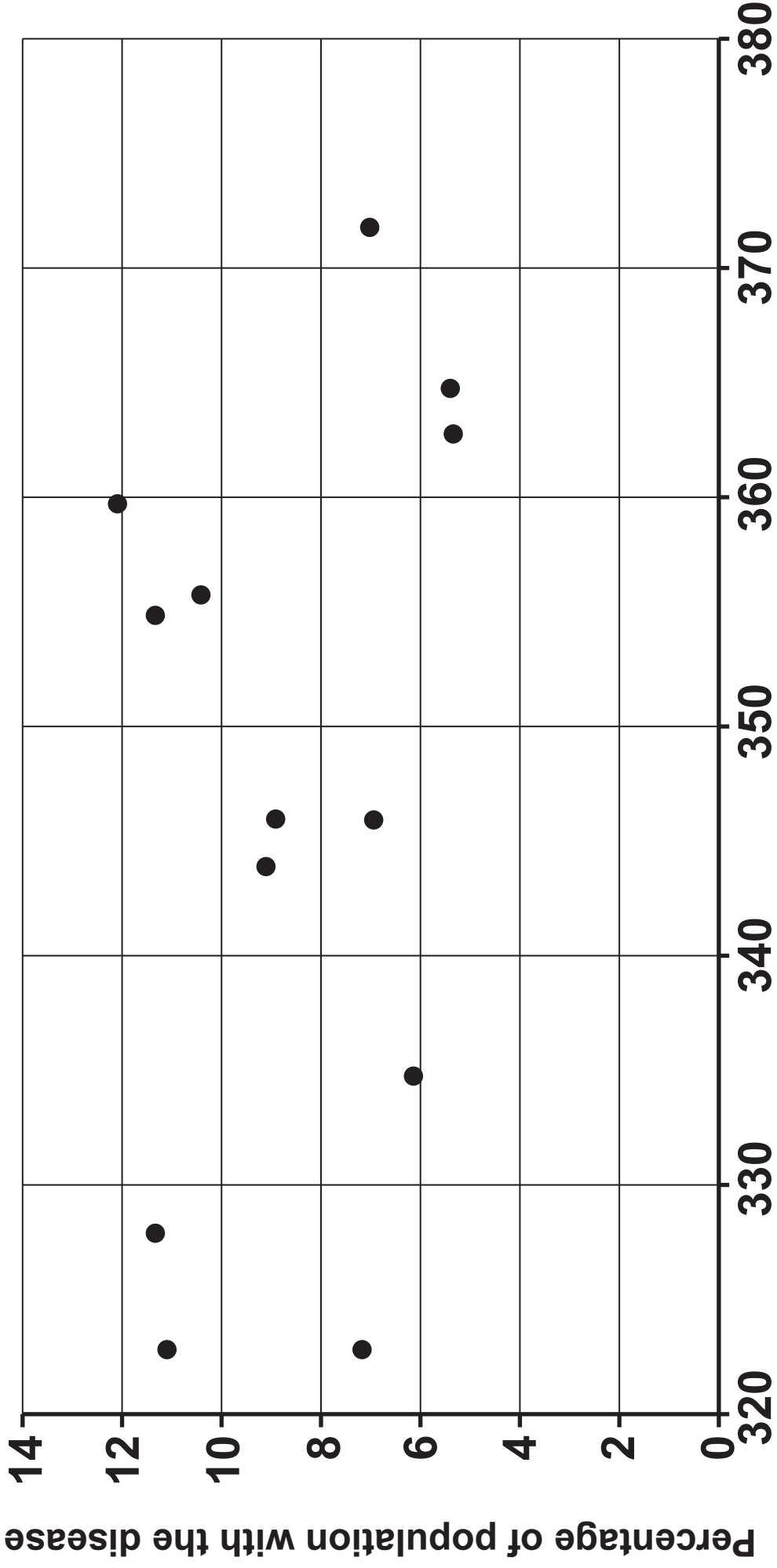

Per capita daily calories from sugar consumption

05. The medical researcher realises that her data is from the year **2000**

She repeats her investigation with a random sample of **13** countries using new data from the year **2020**

She produces the graph opposite.

(b) How should the researcher interpret the new data in the light of the data from **2000**? [2 marks]

SECTION B: DIFFERENTIAL EQUATIONS AND MECHANICS

06. A particle P moves on a horizontal plane, where \underline{i} and \underline{j} are unit vectors in directions east and north respectively. At time t seconds, the position vector of P is given by \underline{r} metres, where

$$\underline{r} = (t^3 - 7t^2)\underline{i} + (2t^2 - 15t + 11)\underline{j}$$

- (a) (i) Find an expression for the velocity vector of P at time t s
- (ii) Determine the value of t when P is moving north-east and hence write down the velocity of P at this value of t [6 marks]
- (b) Find the acceleration vector of P when $t = 7$ [3 marks]

07. A rod AB , of mass 20 kg and length 3.2 m , is resting horizontally in equilibrium on two smooth supports at points X and Y , where $AX = 0.4 \text{ m}$ and $AY = 2.4 \text{ m}$

A particle of mass 8 kg is attached to the rod at a point C , where $BC = 0.2 \text{ m}$

The reaction of the support at Y is four times the reaction of the support at X

You may NOT assume that the rod AB is uniform.

(a) (i) Find the magnitude of each of the reaction forces exerted on the rod at X and Y

(ii) Show that the weight of the rod acts at the midpoint of AB [7 marks]

(b) Is it now possible to determine whether the rod is uniform or non-uniform?
Give a reason for your answer. [1 mark]

(Turn over)

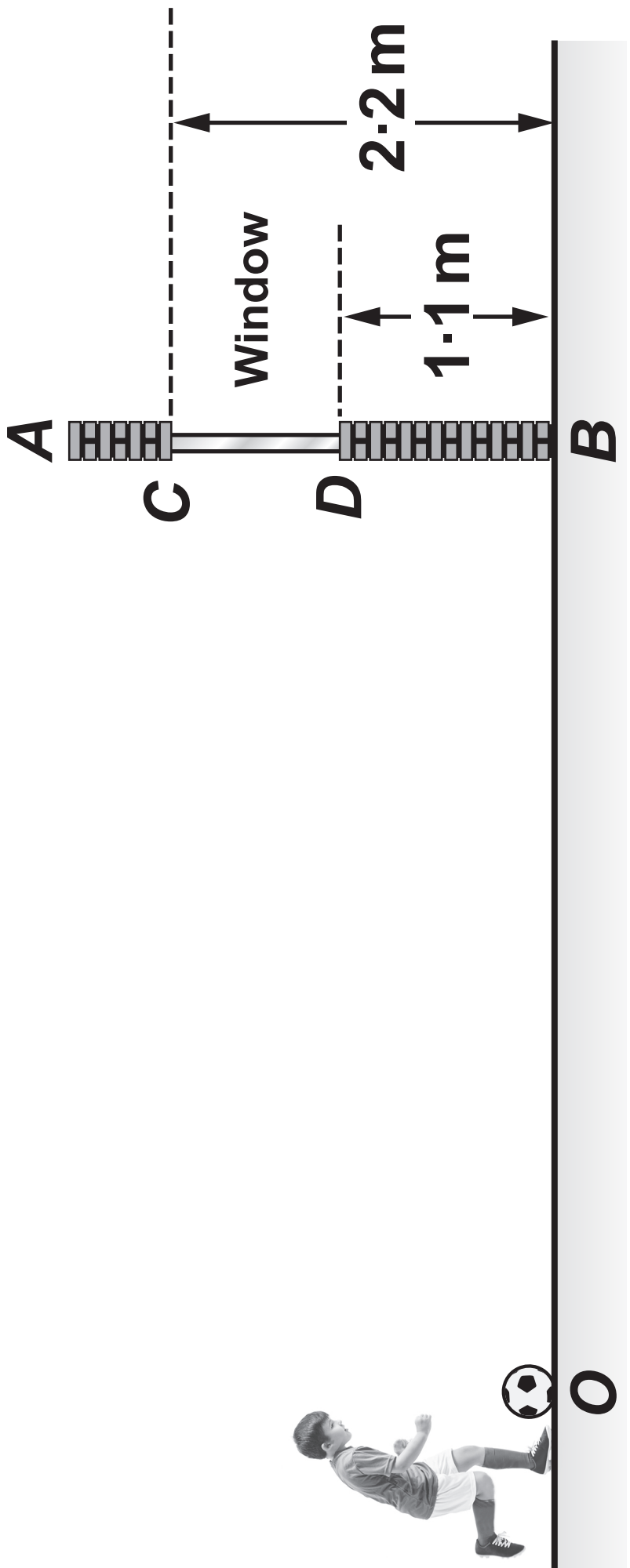

08. A boy kicks a ball from a point O on horizontal ground towards a vertical wall AB . The initial speed of the ball is 23 ms^{-1} in a direction that is 18° above the horizontal. The diagram opposite shows a window CD in the wall AB , such that $BD = 1.1 \text{ m}$ and $BC = 2.2 \text{ m}$. The horizontal distance from O to B is 8 m .

You may assume that the window will break if the ball strikes it with a speed of at least 21 ms^{-1} .

- (a) Show that the ball strikes the window and determine whether or not the window breaks. [7 marks]
- (b) Give one reason why your answer to part (a) may be unreliable. [1 mark]

(Turn over)

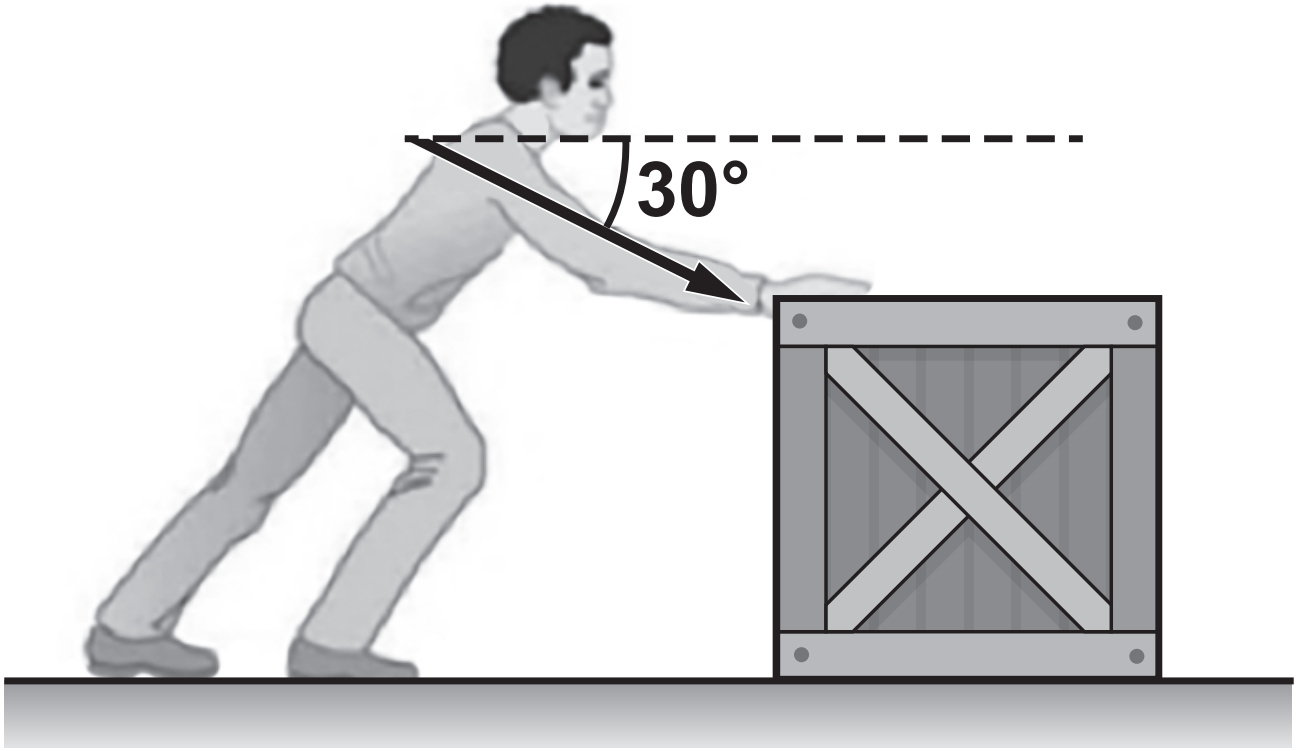

09. The diagram opposite shows a wooden crate of mass **35 kg** being pushed on a rough horizontal floor, by a force of magnitude **380 N** inclined at an angle of **30°** below the horizontal. The crate, which may be modelled as a particle, is moving at a constant speed.

(a) The coefficient of friction between the crate and the floor is μ

Show that

$$\mu = \frac{190\sqrt{3}}{533}$$

[6 marks]

(Turn over)

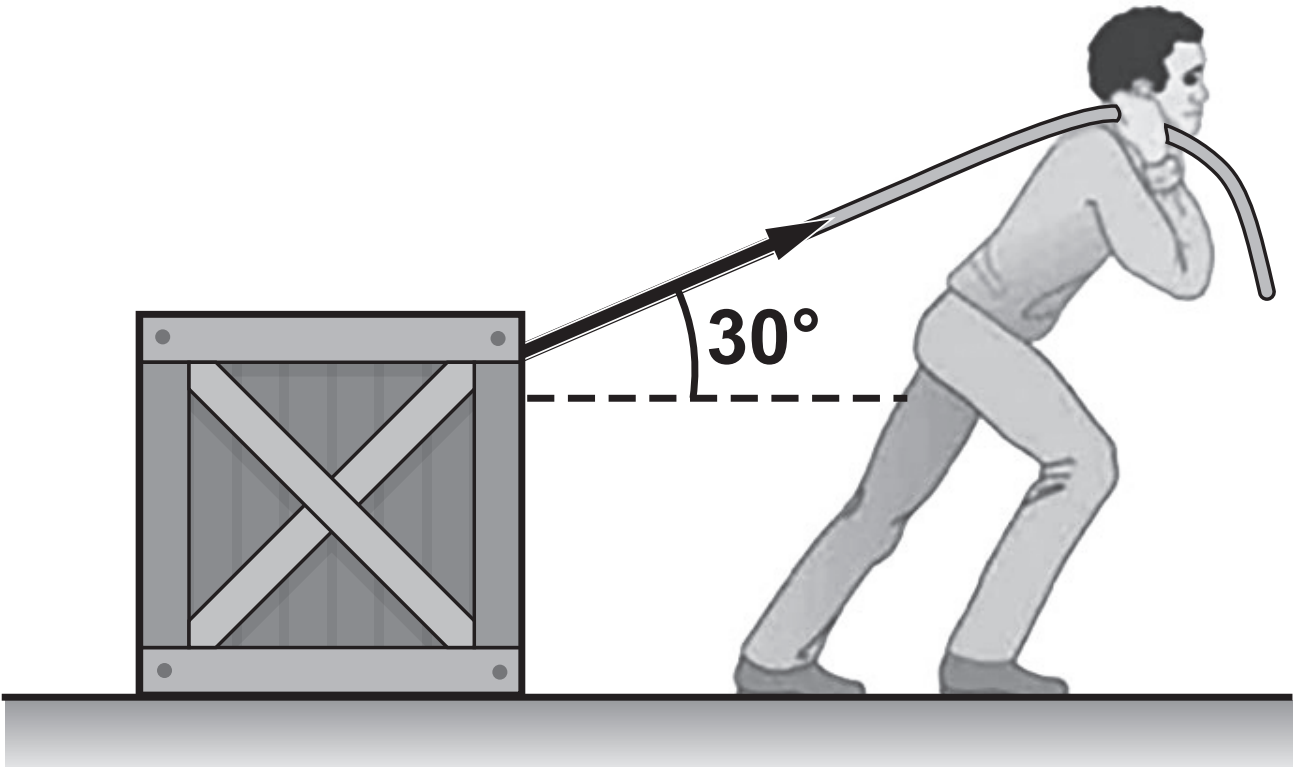

09. Suppose instead that the crate is pulled with the same force of **380 N** inclined at an angle of **30°** above the horizontal, as shown in the diagram opposite.

(b) Without carrying out any further calculations, explain why the crate will no longer move at a constant speed. [1 mark]

10. A train is moving along a straight horizontal track. At time t seconds, its velocity is $v \text{ ms}^{-1}$, its acceleration is $a \text{ ms}^{-2}$, and a is inversely proportional to v .
At time $t = 1$, $v = 5$ and $a = 1.8$

- (a) (i) Write down a differential equation satisfied by v
- (ii) Show that $v^2 = 18t + 7$ [6 marks]
- (b) Find the time at which the magnitude of the velocity is equal to the magnitude of the acceleration. [2 marks]

END OF PAPER