



GCE A LEVEL

1305U60-1

WEDNESDAY, 14 JUNE 2023 – AFTERNOON

FURTHER MATHEMATICS – A2 unit 6

FURTHER MECHANICS B

1 hour 45 minutes plus your additional time allowance

ADDITIONAL MATERIALS

In addition to this examination paper, you will need:

- a WJEC pink 16-page answer booklet;
- a Formula Booklet;
- a calculator.

INSTRUCTIONS TO CANDIDATES

Use black ink, black ball-point pen or your usual method.

Answer ALL questions.

Take g as 9.8 ms^{-2}

Sufficient working must be shown to demonstrate the MATHEMATICAL method employed.

Answers without working may not gain full credit.

Unless the degree of accuracy is stated in the question, answers should be rounded appropriately.

(Turn over)

INFORMATION FOR CANDIDATES

The maximum mark for this paper is 80.

The number of marks is given in brackets at the end of each question or part-question.

You are reminded of the necessity for good English and orderly presentation in your answers.

ADDITIONAL FORMULAE FOR 2023**LAWS OF LOGARITHMS**

$$\log_a x + \log_a y \equiv \log_a (xy)$$

$$\log_a x - \log_a y \equiv \log_a \left(\frac{x}{y} \right)$$

$$k \log_a x \equiv \log_a (x^k)$$

SEQUENCES

General term of an arithmetic progression:

$$u_n = a + (n - 1)d$$

General term of a geometric progression:

$$u_n = ar^{n-1}$$

(Turn over)

MENSURATION

For a circle of radius, r , where an angle at the centre of θ radians subtends an arc of length S and encloses an associated sector of area A :

$$s = r\theta$$

$$A = \frac{1}{2} r^2 \theta$$

CALCULUS AND DIFFERENTIAL EQUATIONS**DIFFERENTIATION****FUNCTION****DERIVATIVE**

$f(x)g(x)$

$f'(x)g(x) + f(x)g'(x)$

$f(g(x))$

$f'(g(x))g'(x)$

(Turn over)

INTEGRATION

FUNCTION

$$f'(g(x))g'(x)$$

INTEGRAL

$$f(g(x)) + c$$

$$\text{Area under a curve} = \int_a^b y dx$$

(Turn over)

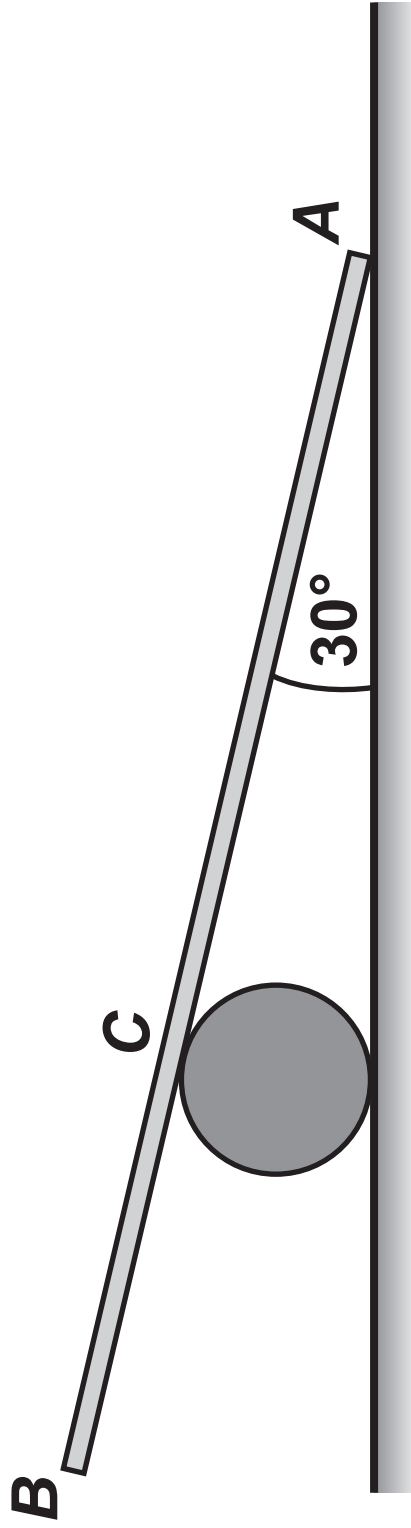

REMINDER: Sufficient working must be shown to demonstrate the MATHEMATICAL method employed.

1. The diagram opposite shows a uniform rod ***AB***, of length **8 m** and mass **23 kg**, in limiting equilibrium with its end ***A*** on rough horizontal ground and point ***C*** resting against a smooth fixed cylinder. The rod is inclined at an angle of **30°** to the ground.

The coefficient of friction between the ground and the rod is $\frac{2}{3}$

- (a) Calculate the magnitude of the normal reaction at ***C*** and the magnitude of the normal reaction to the ground at ***A*** [8 marks]
- (b) Find the length ***AC*** [4 marks]

(Turn over)

- 1 (c) Suppose instead that the rod is **NON-UNIFORM** with its centre of mass closer to ***A*** than to ***B*** **WITHOUT CARRYING OUT ANY FURTHER CALCULATIONS**, state whether or not this will affect your answers in part (a). Give a reason for your answer. [1 mark]

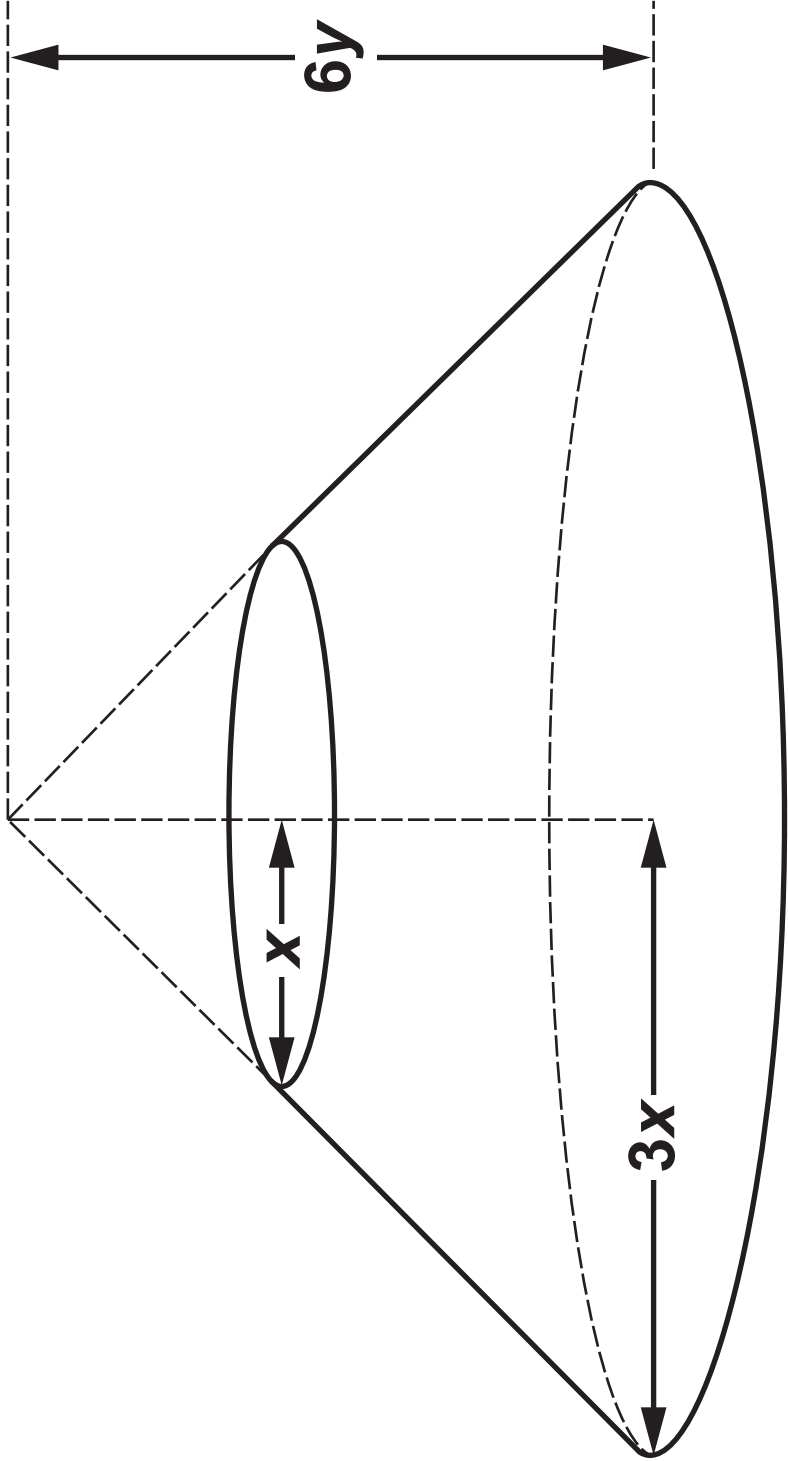

2. You are given that the centre of mass of a uniform solid cone of height h and base radius r is at a height of $\frac{1}{4}h$ above its base.

The diagram opposite shows a solid conical frustum. It is formed by taking a uniform right circular cone, of base radius $3x$ and height $6y$ and removing a smaller cone, of base radius x with the same vertex.

Show that the distance of the centre of mass of the frustum from its base along the axis of

symmetry is $\frac{18}{13}y$ [7 marks]

Harbour wall

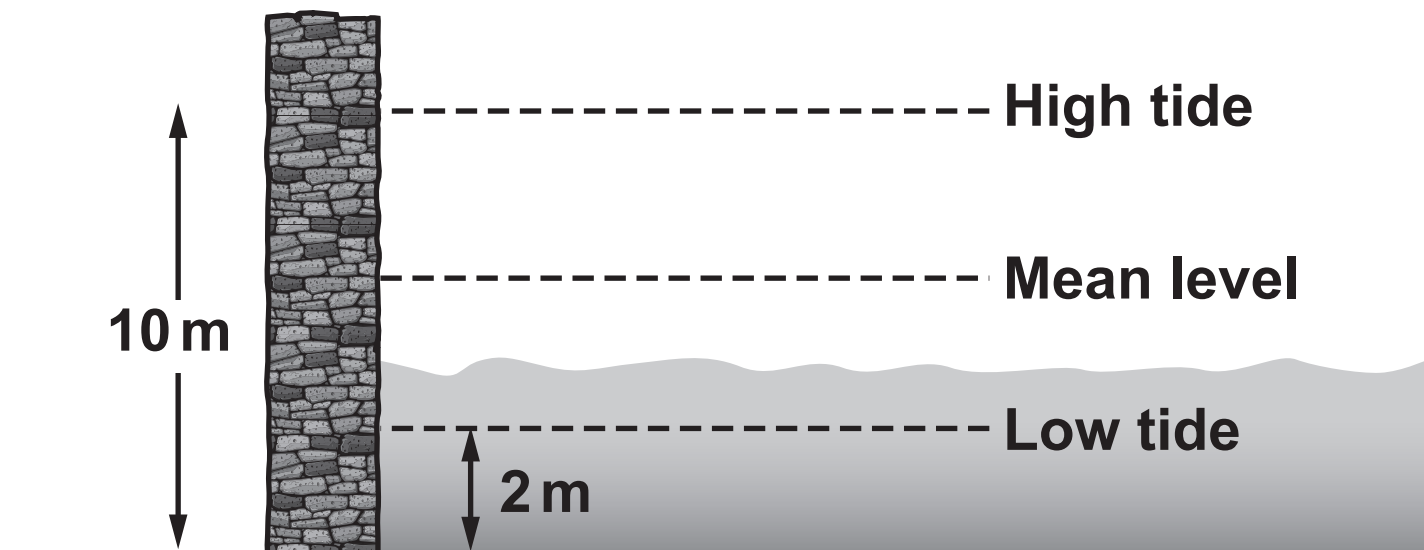

Tidal Times		
High / Low	Time	Depth (metres)
Low Tide	5 a.m.	2
High Tide	11 a.m.	10
Low Tide	5 p.m.	2
High Tide	11 p.m.	10

3. The vertical motion of a point on the surface of the water in a certain harbour may be modelled as Simple Harmonic Motion about a mean level. The diagram opposite shows that, on a particular day, the depth of water in the harbour at low tide is **2 m** and the depth of the water in the harbour at high tide is **10 m**. The table opposite shows the times of high and low tides on this day.

- (a) Write down the period and amplitude of the motion. [2 marks]
- (b) Let **x m** denote the height of water above mean level **t hours after 5 a.m.**
Find an expression for **x** in terms of **t** [3 marks]

- 3 (c) The depth of water must be at least **4 m** for boats to safely use the harbour. Determine the earliest time, after low tide at **5 a.m.** at which boats can safely leave the harbour and hence find the latest possible time of return before the next low tide. [4 marks]
- (d) Calculate the rate at which the level of water is falling at **2 p.m.** [4 marks]

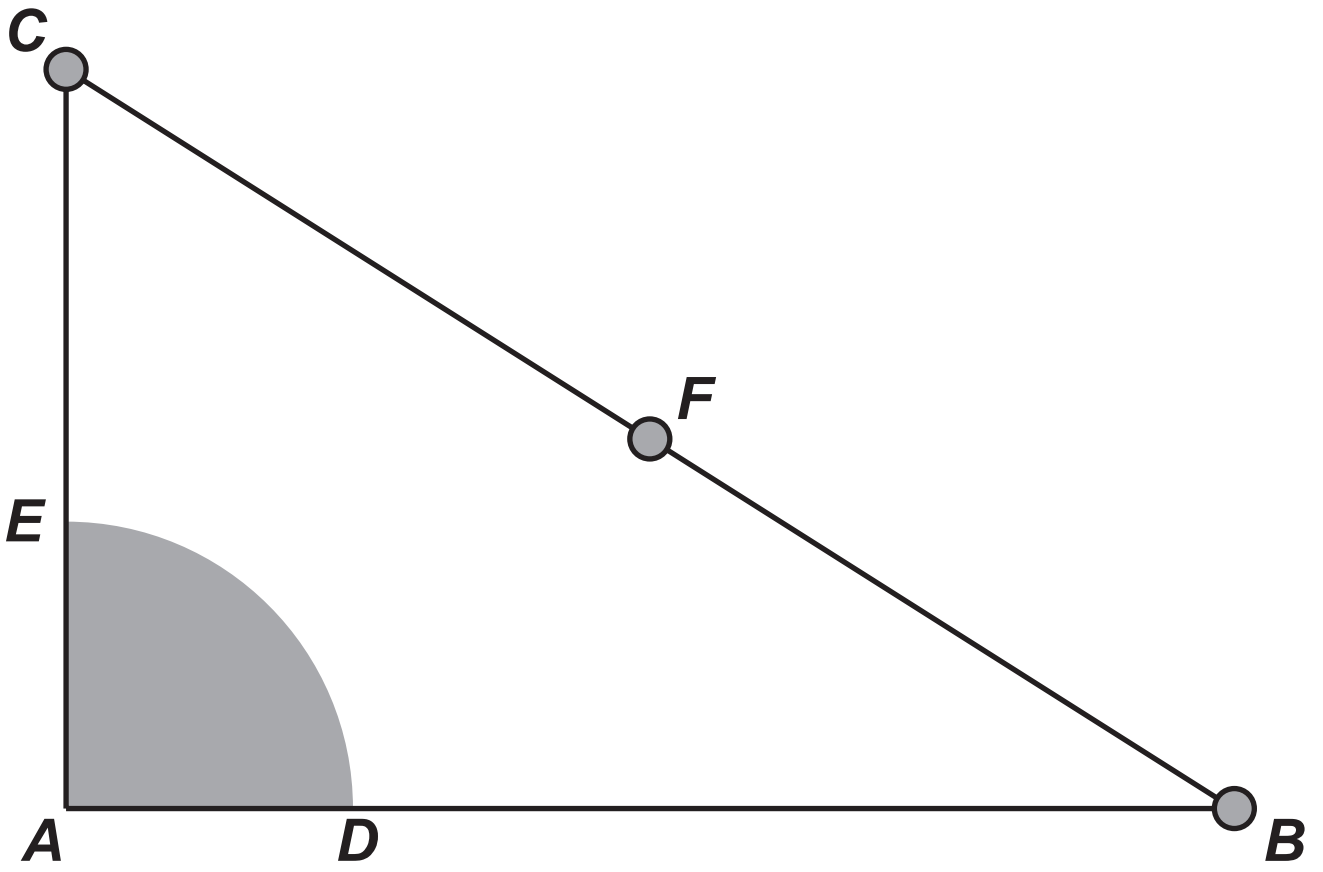

4. The diagram opposite shows three LIGHT rods AB , BC and CA rigidly joined together so that ABC is a right-angled triangle with $AB = 45 \text{ cm}$, $AC = 28 \text{ cm}$ and $\hat{CAB} = 90^\circ$

The rods support a uniform lamina, of density 2 m kg / cm^2 , in the shape of a quarter circle ADE with radius 12 cm and centre at the vertex A

Three particles are attached to BC : one at B , one at C and one at F , the midpoint of BC

The masses at C , F and B are 50 m kg , 30 m kg and 20 m kg respectively.

- (a) Calculate the distance of the centre of mass of the system from
- (i) AC
- (ii) AB

[11 marks]

(Turn over)

4 (b) When the system is freely suspended from a point P on AC , it hangs in equilibrium with AB vertical. Write down the length AP

[1 mark]

(c) When the system is freely suspended from a point Q on AD , it hangs in equilibrium with QB making an angle of 60° with the vertical. Find the distance AQ

[3 marks]

5. In this question, \underline{i} and \underline{j} represent unit vectors due east and due north respectively.

Two smooth spheres P and Q , of equal radii, are moving on a smooth horizontal surface. The mass of P is 2 kg and the mass of Q is 6 kg . The velocity of P is $(8\underline{i} - 6\underline{j}) \text{ ms}^{-1}$ and the velocity of Q is $(4\underline{i} + 10\underline{j}) \text{ ms}^{-1}$.

At a particular instant, Q is positioned 12 m east and 48 m south of P .

- (a) Prove that P and Q will collide. [4 marks]

At the instant the spheres collide, the line joining their centres is parallel to the vector \underline{j} . Immediately after the collision, sphere Q has speed 5 ms^{-1} .

- 5 (b) Determine the coefficient of restitution between the spheres and hence calculate the velocity of P immediately after the collision. [9 marks]
- (c) Find the magnitude of the impulse required to stop sphere P after the collision. [3 marks]

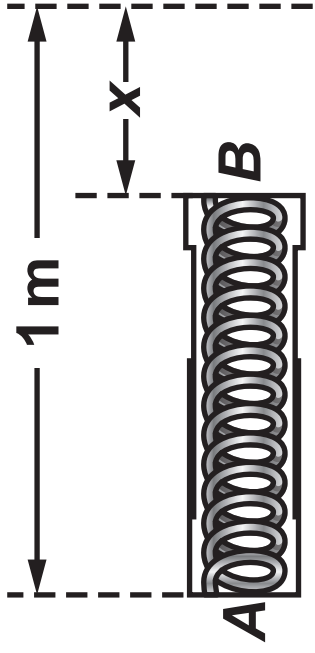
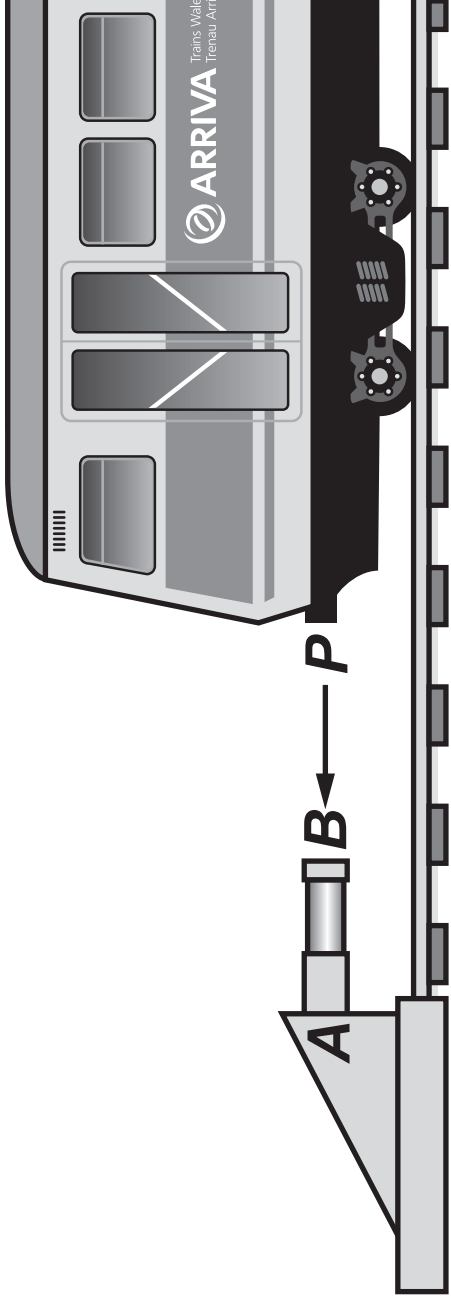

6. The diagram opposite on the left shows a train of mass **50** tonnes approaching a buffer at the end of a straight horizontal railway track. The buffer is designed to prevent the train from running off the end of the track. The buffer may be modelled as a light horizontal spring **AB** , as shown in the diagram opposite on the right, which is fixed at the end **A** . The train strikes the buffer so that **P** makes contact with **B** at **$t = 0$** seconds.

While **P** is in contact with **B** , an additional resistive force of **$250\,000v$ N** will oppose the motion of the train, where **$v\text{ms}^{-1}$** is the speed of the train at time **t** seconds. The spring has natural length **1m** and modulus of elasticity **$312\,500\text{N}$**

At time **t** seconds, the compression of the spring is **X** metres.

- 6 (a) Show that, while P is in contact with B
 X satisfies the differential equation

$$4 \frac{d^2x}{dt^2} + 20 \frac{dx}{dt} + 25x = 0$$

[4 marks]

- (b) Given that, when P first makes contact with B
the speed of the train is $U \text{ ms}^{-1}$
find an expression for X in terms of U and t

[8 marks]

- (c) When the train comes to rest, the compression of
the buffer is 0.3 m

Determine the speed of the train when it strikes
the buffer.

[3 marks]

(Turn over)

6 (d) State which type of damping is described by the motion of *P*

Give a reason for your answer.

[1 mark]

END OF PAPER