



**GCE AS/A LEVEL**

**2300U20-1**

**THURSDAY, 25 MAY 2023 – AFTERNOON**

**MATHEMATICS – AS unit 2**

**APPLIED MATHEMATICS A**

**1 hour 45 minutes plus your additional  
time allowance**

## **ADDITIONAL MATERIALS**

**In addition to this examination paper, you will need:**

- **a WJEC pink 16-page answer booklet;**
- **a Formula Booklet;**
- **a calculator;**
- **statistical tables (RND/WJEC Publications).**

## **INSTRUCTIONS TO CANDIDATES**

**Use black ink, black ball-point pen or your usual method.**

**Answer ALL questions.**

**Write your answers in the separate answer booklet provided, following the instructions on the front of the answer booklet.**

**(Turn over)**

**Use both sides of the paper. Please only write within the white areas of the booklet.**

**Write the question number in the left-hand margin at the start of each answer. Write the sub parts, e.g. (a), (b) and (c), within the white areas of the booklet.**

**Leave at least two line spaces between each answer.**

**Take  $g$  as  $9.8 \text{ ms}^{-2}$**

**Sufficient working must be shown to demonstrate the MATHEMATICAL method employed.**

**Answers without working may not gain full credit.**

**(Turn over)**

**Unless the degree of accuracy is stated in the question, answers should be rounded appropriately.**

## **INFORMATION FOR CANDIDATES**

**The maximum mark for this paper is 75.**

**The number of marks is given in brackets at the end of each question or part-question.**

**You are reminded of the necessity for good English and orderly presentation in your answers.**

**(Turn over)**

**ADDITIONAL FORMULAE FOR 2023****LAWS OF LOGARITHMS**

$$\log_a x + \log_a y \equiv \log_a (xy)$$

$$\log_a x - \log_a y \equiv \log_a \left( \frac{x}{y} \right)$$

$$k \log_a x \equiv \log_a (x^k)$$

**(Turn over)**

**SEQUENCES**

**General term of an arithmetic progression:**

$$u_n = a + (n - 1) d$$

**General term of a geometric progression:**

$$u_n = ar^{n-1}$$

**(Turn over)**

**MENSURATION**

For a circle of radius,  $r$ , where an angle at the centre of  $\theta$  radians subtends an arc of length  $S$  and encloses an associated sector of area  $A$  :

$$s = r\theta$$

$$A = \frac{1}{2} r^2 \theta$$

**CALCULUS AND DIFFERENTIAL  
EQUATIONS**

**DIFFERENTIATION**

**FUNCTION**

**DERIVATIVE**

**$f(x)g(x)$**

**$f'(x)g(x) + f(x)g'(x)$**

**$f(g(x))$**

**$f'(g(x))g'(x)$**

**(Turn over)**

**INTEGRATION****FUNCTION**

$$f'(g(x))g'(x)$$

**INTEGRAL**

$$f(g(x)) + c$$

$$\text{Area under a curve} = \int_a^b y dx$$

**(Turn over)**

**REMINDER: Sufficient working must be shown to demonstrate the MATHEMATICAL method employed.**

**SECTION A: STATISTICS**

**01. The events  $A$  and  $B$  are such that  
 $P(A) = 0.3$ ,  $P(B) = 0.2$   
and  $P(A \cap B) = 0.1$**

**(a) Find  $P(A \cup B)$  [2 marks]**

**The event  $C$  is such that**

$$**P(C) = 0.45**$$

**The events  $B$  and  $C$  are independent.**

**(Turn over)**

01 (b)

Find  $P(B \cap C)$

[2 marks]

The events  $A$  and  $C$  are mutually exclusive.

(c) Draw a Venn diagram to show the events  $A$ ,  $B$  and  $C$   
Include the probability for each distinct region on your diagram.

[4 marks]

(d) Find  $P((B \cup C)')$

[2 marks]

(Turn over)

**02. A card is selected at random from a pack of 20 cards numbered 1 to 20**

**What distribution models the number on the card? Give a reason for your answer. [2 marks]**

03. The probability distribution of a discrete random variable  $X$  is given below.

$x$	4	8	16
$P(X = x)$	0.3	0.5	0.2

Two independent values of  $X$  are generated. Find the probability that the first value of  $X$  is less than or equal to the second value of  $X$

[4 marks]

(Turn over)

- 04. Sources of the radioactive element caesium each emit radioactive particles at an average rate of 4 per second. The numbers of emissions are modelled by a Poisson distribution.**
- (a) Find the probability that, in a 3-second interval, one such source will emit at least 10 radioactive particles, giving your answer correct to 4 decimal places. [3 marks]**

**(Turn over)**

**04 (b)**

**A random sample of 9 of these sources is taken. Calculate the probability that at most 5 of them will emit at least 10 radioactive particles in a 3-second interval.**

**[3 marks]**

**(Turn over)**

**05. A doctor knows that 34% of his patients currently take too little exercise. He believes he can reduce this proportion by putting patients through a behaviour change programme.**

**To test his belief, he takes a random sample of 156 of his patients and puts each of them through the programme.**

**It is found that 40 of these patients take too little exercise following the behaviour change programme.**

**05 (a)**

**The doctor initially considers using a two-tailed test. Explain why this is not appropriate. [1 mark]**

**(b) The doctor then decides to use a one-tailed test.**

**(i) Explain what is meant by a  $p$ -value in the context of this question. [1 mark]**

**(ii) Test the doctor's belief at the 1% level of significance, stating clearly the conclusion that the doctor should reach. [6 marks]**

**(Turn over)**

**06. Poppi and Clare are investigating Welsh language skills in Wales. Poppi randomly selects a sample of 20 different students from her school and asks them to state their Welsh language skills according to the categories in the 2011 census. She numbers the students in her school from 001 to 578. She uses a random number generator to select her sample. The first 6 numbers generated are shown below.**

**195**

**752**

**023**

**195**

**432**

**271**

**(Turn over)**

**06 (a)**

**Write down the numbers of the first 4 students in Poppi's sample.**

**[1 mark]**

**Clare selects a random sample of 20 students from a different school.**

**(b) Give two reasons why Clare's conclusion about Welsh language skills in Wales may be different from Poppi's conclusion. [2 marks]**

**(Turn over)**

	No skills in Welsh	Understand spoken Welsh only	Speak Welsh	Other skills in Welsh
<b>Region A</b>	<b>Number of people</b>	<b>111 232</b>	<b>5517</b>	<b>13 103</b>
	<b>Percentage</b>	<b>82.6</b>	<b>4.1</b>	<b>9.7</b>
<b>Region B</b>	<b>Number of people</b>	<b>102 153</b>	<b>4083</b>	<b>2744</b>
	<b>Percentage</b>	<b>83.7</b>	<b>3.3</b>	<b>2.2</b>

**06. The data collected from the 2011 census for two regions in Wales are shown opposite.**

**On looking at these data, Poppi concludes that people in Region B have better Welsh language skills than people in Region A.**

**(c) Without carrying out any calculations, use data from the table**

**(i) to argue for Poppi's conclusion,**

**(ii) to argue against Poppi's conclusion.**

**[2 marks]**

**(Turn over)**

**06 (d)**

**Seven 4-year-old children who “Speak Welsh” were asked to concentrate on a task. The times, in minutes, until they lost concentration are given below.**

**7·2**

**5·4**

**7·4**

**4·6**

**13·2**

**8·4**

**7·7**

- (i) Calculate the mean and standard deviation for these data. [3 marks]**

**(Turn over)**

**06 (d) (ii)**

**For a similar group of 4-year-olds with “No skills in Welsh”, the mean concentration time is 6·5 minutes and the standard deviation is 3·5 minutes. Compare the concentration times for these two groups of 4-year-olds. [2 marks]**

**(Turn over)**

**SECTION B: MECHANICS**

- 07.** A person is standing in a lift which is descending with a constant acceleration of  $\frac{g}{10} \text{ ms}^{-2}$

The lift is supported by a single cable.

- (a)** The total mass of the lift and the person is **1200 kg**  
Find the tension in the lift cable.

**[3 marks]**

**(Turn over)**

07 (b)

The mass of the person is  $M$  kg

Given that the magnitude of the reaction of the floor of the lift on the person is  $63$  gN

find the value of  $M$

[3 marks]

(Turn over)

08. A particle  $P$  moves in a straight line such that its displacement,  $S$  metres, at time  $t$  seconds, relative to a fixed point is given by

$$s = 4t^2 - t^3 \quad \text{for } t \geq 0$$

Find the speed of  $P$  when it returns to its starting position. [5 marks]

(Turn over)

09. Three forces  $\underline{F}$ ,  $\underline{G}$  and  $\underline{H}$  are such that

$$\underline{F} = (2\underline{i} - 13\underline{j}) \text{ N}$$

$$\underline{G} = (-6\underline{i} + 8\underline{j}) \text{ N}$$

$$\underline{H} = (12\underline{i} + k\underline{j}) \text{ N}$$

where  $k$  is a constant. The resultant of the three forces,  $\underline{R}$ , has magnitude 17 N

(Turn over)

09 (a)

Find the two possible values of the constant  $k$  [4 marks]

(b) For the larger of the two values of  $k$  calculate the angle that  $\underline{R}$  makes with the  $\underline{i}$  vector. [2 marks]

(Turn over)

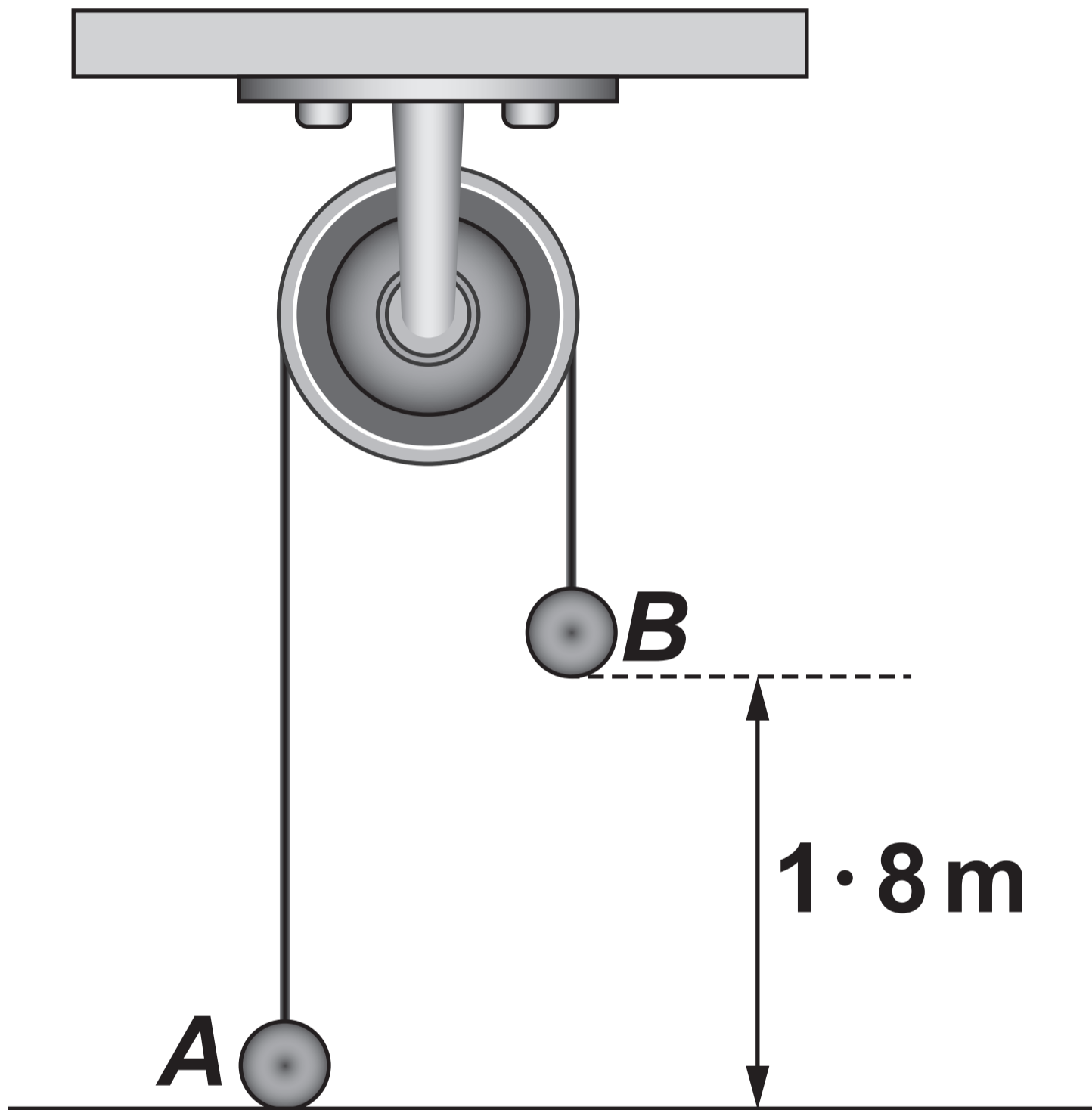

**10.** The diagram opposite shows two objects ***A*** and ***B*** connected by a light inextensible string passing over a smooth fixed pulley. Object ***A*** has mass  **$4.5 \text{ kg}$**  and object ***B*** has mass  **$7.5 \text{ kg}$**

Initially, object ***A*** is held on a horizontal surface so that object ***B*** hangs freely with the string taut.

The distance of object ***B*** above the horizontal surface is  **$1.8 \text{ m}$**

**(a)** Write down the tension in the string connecting the two objects. [1 mark]

**(Turn over)**

10 (b)

Object **A** is then released.

- (i) Calculate the magnitude of the acceleration of **A**
  
- (ii) Hence, find the time taken for the objects to be at the same height above the horizontal surface.
  
- (iii) In reality, there will be air resistance acting on the objects as they move. State how this fact will affect your answer to (ii). [9 marks]

(Turn over)

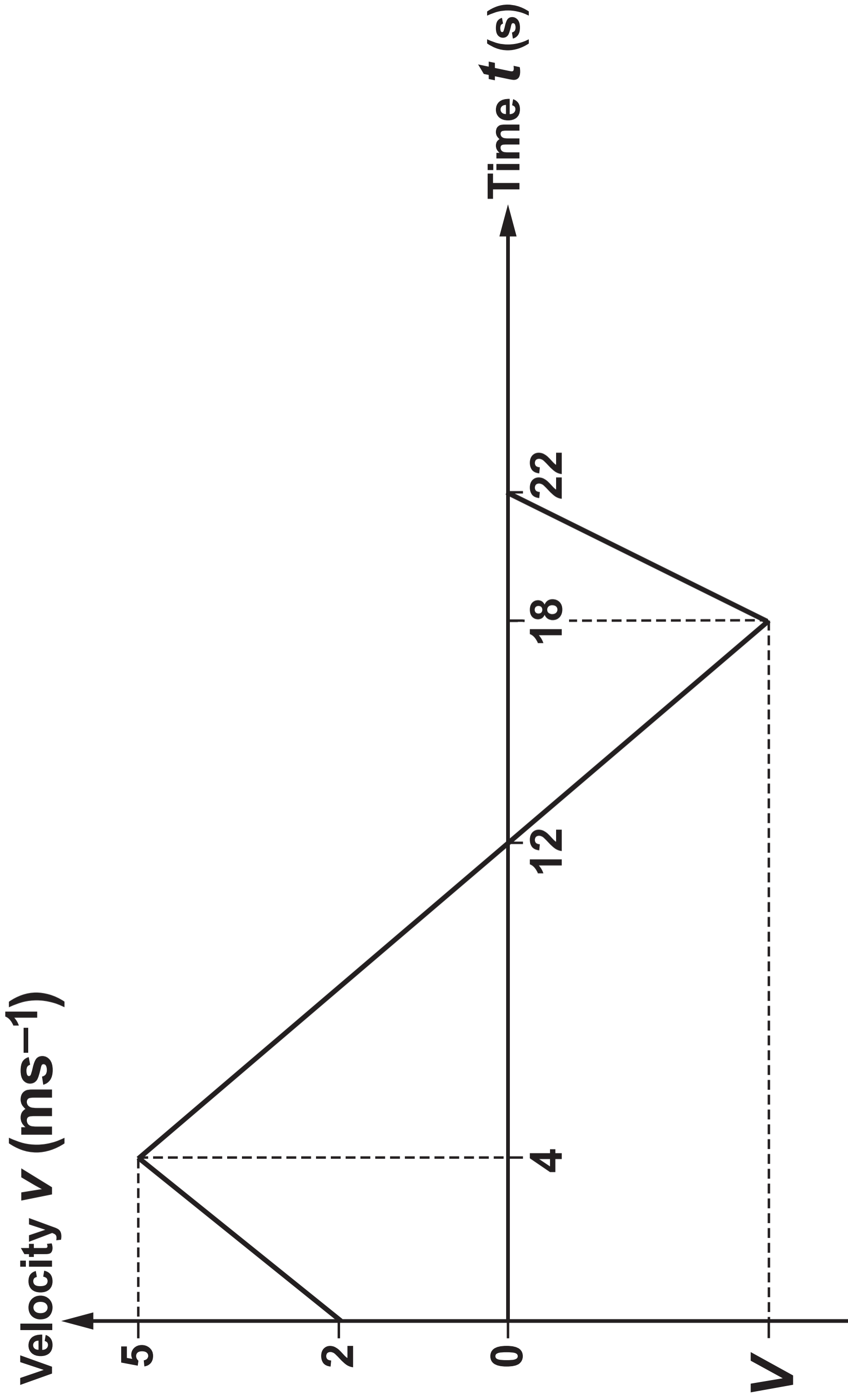

11. A particle, which is initially at the point **A**, travels in a straight line during the interval  $0 \leq t \leq 22$  where  $t$  is the time in seconds. The diagram opposite shows a velocity-time graph for the motion of the particle. The velocity of the particle when  $t = 18$  is  $V \text{ms}^{-1}$
- (a) Find the acceleration of the particle when  $t = 1$  [2 marks]
- (b) Calculate the distance travelled by the particle during the interval  $0 \leq t \leq 12$  [2 marks]

(Turn over)

11 (c)

When  $t = 22$ , the displacement of the particle from  $A$  is  $14\text{ m}$

Determine the value of  $V$  [3 marks]

(d)

Write down the time interval during which the particle is moving towards  $A$  and its speed is increasing.

[1 mark]

**END OF PAPER**