



**GCE A LEVEL**

**1500U40-1**

**TUESDAY, 18 JUNE 2024 – AFTERNOON**

**COMPUTER SCIENCE – A2 unit 4**

**Computer Architecture, Data, Communication and Applications**

**2 hours plus your additional time allowance**

**ADDITIONAL MATERIALS**

**A WJEC pink 16-page answer booklet.**

**A calculator.**

**INSTRUCTIONS TO CANDIDATES**

**Use black ink, black ball-point pen or your usual method.**

**Answer ALL questions.**

**Write your answers in the separate answer booklet provided.**

**Write the question number in the left-hand margin at the start of each answer.**

**INFORMATION FOR CANDIDATES**

**The number of marks is given in brackets at the end of each question or part-question; you are advised to divide your time accordingly.**

**The total number of marks available is 100.**

**Assessment will take into account the quality of written communication used in your answers.**

**(Turn over)**

**Answer ALL questions.**

- 1. Describe the role of three of the main components of a contemporary Central Processing Unit (CPU). [6 marks]**

- 2. AJ Jewellers uses a direct access file with a separate overflow area to store stock records. Each record has a key field made up from a four-digit code followed by the year number, for example: 137524, 701924.**

**It is proposed to use the hashing algorithm: key field MOD 1000**

- (a) Calculate the location of the stock records for each of the two example key fields. [2 marks]**
- (b) Explain why this hashing algorithm is unsuitable. [3 marks]**
- (c) Give an example of a more suitable hashing algorithm for the file. [1 mark]**

**(Turn over)**

3. **AJ Jewellers has invested in a 3D printing system to produce objects in precious metals. The system includes CAD software and a double buffering printer interface.**

**Explain why the 3D printing system uses double buffering. [4 marks]**

4 (a) The maximum increase in speed due to parallel processing can be calculated as:

$$\frac{1}{S + \frac{P}{N}}$$

where P = parallel fraction,  
N = number of processors and  
S = serial fraction. (S = 1 – P)

- (i) Calculate the maximum increase in speed due to parallel processing using 2 processors and the increase in speed of doing the same task using 20 processors, where the parallel fraction P is equal to:
- 0.5 for 2 and 20 processors
  - 0.9 for 2 and 20 processors [2 marks]
- (ii) Explain the limiting factor of parallel processing indicated by your calculations. [4 marks]
- (b) Explain TWO other limiting factors to parallelisation in parallel processing. [4 marks]

5. An interrupt is a signal that is sent to the processor to request immediate attention. The operating system will have interrupt service routines designed to process each interrupt.
- (a) Identify TWO events which could generate an interrupt. [2 marks]
- (b) Priorities are used when more than one device raises an interrupt. Describe how priorities are used when handling interrupts. [4 marks]
- (c) Describe the process carried out when an interrupt affects the execution of the fetch-decode-execute cycle of a running program. [6 marks]

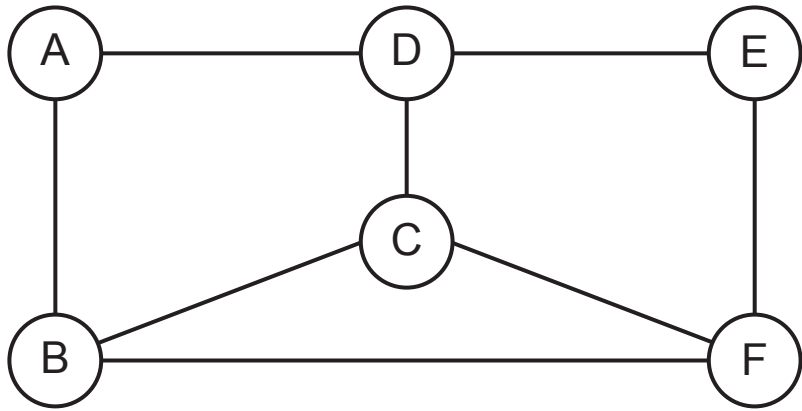

6. A series of nodes are connected in a network, as shown opposite:

For this network a node-to-node transmission speed of 1 Mbps would produce a routing cost = 1. The costs for routing data packets between nodes are given in the table.

NETWORK LINKS	TRANSMISSION SPEED (KBPS)	ROUTING COST
A–B	250	4
A–D	(i)	20
B–C	100	10
B–F	80	(ii)
C–D	250	4
C–F	500	(iii)
D–E	100	10
E–F	250	4

- (a) State the values that should be in cells (i), (ii) and (iii) of the table. [3 marks]
- (b) Packets are transmitted using the route that has the lowest total cost. State the route that packets would take from node A to node F. [1 mark]

(Turn over)

7. **A secure display cabinet in AJ Jewellers' showroom has an electronic lock which is opened by entering a four-digit code number using a keypad.**

**A copy of the correct code number is stored in a computer at memory location 01A0.**

**The cabinet is opened when the computer sends a numeric value of  $-1$  to the electronic lock.**

**A control program for the lock is to be written in assembly language. The required algorithm is:**

**Repeat**

**input a code number from the keypad**

**subtract the value stored in 01A0 from the input**

**Until the remainder is zero**

**output  $-1$**

**(Turn over)**

7. The assembly language used by the computer has an instruction set, which includes the following commands:

<b>ASSEMBLY LANGUAGE COMMAND</b>	<b>DESCRIPTION</b>
<b>IN</b>	<b>Input a numeric code from the keypad to the accumulator</b>
<b>OUT R</b>	<b>Output a numeric value R to the electronic lock</b>
<b>ADD N</b>	<b>Add the numeric value in location N to the accumulator, leaving the result in the accumulator</b>
<b>SUB N</b>	<b>Subtract the numeric value in location N from the accumulator, leaving the result in the accumulator</b>
<b>JMP LABEL</b>	<b>Jump to LABEL</b>
<b>JZE LABEL</b>	<b>Jump to LABEL if the contents of the accumulator are equal to zero</b>

**Using the given algorithm and instruction set, write a program to control the electronic lock.**

**[6 marks]**

**(Turn over)**

8 (a) Explain, using a suitable example, the difference between truncating and rounding a real number when stored as an integer in a 4-bit register.

[4 marks]

(b) Convert the hexadecimal numbers  $1A_{16}$  and  $-14_{16}$  into two 8-bit binary numbers, using two's complementation. Using binary addition, calculate the binary number that would result from adding the two numbers. [4 marks]

(c) In a certain computer system, real numbers are stored in floating point form using 16-bits as shown.

MANTISSA	EXPONENT
12-bits in two's complement form. The binary point in the mantissa is immediately after the left bit	4-bits in two's complement form

Clearly showing your working, convert  $52.875_{10}$  into this format. [3 marks]

(Turn over)

- 8 (d) In a different computer system, real numbers are stored in floating point form with an 8-bit signed mantissa and a 4-bit signed exponent.

Calculate the denary value of 00100101 0101.

[3 marks]

9. A database administrator will refer to data dictionaries and use a Database Management System (DBMS) in their work.

- (a) Describe the contents of a data dictionary.

[2 marks]

- (b) Explain the purpose of a DBMS. [6 marks]

10. **AJ Jewellers offers a jewellery valuation service. Clients requiring a valuation submit a valuation request with details of the different items to be valued. Each item is assessed and given an individual valuation. The same valuer will assess all items requested by the client.**

**A flat file database is used to organise details of the valuations. The database stores information about clients, their jewellery, the valuations and the experts used.**

- (a) Identify TWO potential problems arising from the use of a flat file. [2 marks]**
- (b) The database is to be restructured into third normal form, using four tables.**
- (i) Draw an entity-relationship diagram for the revised database structure. [4 marks]**
- (ii) Design a database for this situation. [4 marks]**

## Cars

<b>CarID</b>	<b>MAKE</b>	<b>MODEL</b>	<b>TYPE</b>
<b>C10</b>	<b>Ford</b>	<b>Focus</b>	<b>Electric</b>
<b>C11</b>	<b>Renault</b>	<b>Clio</b>	<b>Petrol</b>
<b>C15</b>	<b>Toyota</b>	<b>Yaris</b>	<b>Hybrid</b>
<b>C16</b>	<b>Volkswagen</b>	<b>Golf</b>	<b>Electric</b>

## Members

<b>MemberID</b>	<b>NAME</b>	<b>ADDRESS1</b>	<b>ADDRESS2</b>
<b>10</b>	<b>Elliott James</b>	<b>1 High Street</b>	<b>Llanperry</b>
<b>20</b>	<b>Ada Patel</b>	<b>2 Long Road</b>	<b>Llanperry</b>
<b>25</b>	<b>Rohan Charles</b>	<b>12 Grange Rise</b>	<b>Penpark</b>
<b>26</b>	<b>Gracie Smith</b>	<b>21 Castle View</b>	<b>Penpark</b>

## CarHireMarch

<b>DATE</b>	<b>HOURS</b>	<b>CARID</b>	<b>MEMBERID</b>
<b>2 Mar 24</b>	<b>3</b>	<b>C10</b>	<b>10</b>
<b>3 Mar 24</b>	<b>2</b>	<b>C11</b>	<b>20</b>
<b>3 Mar 24</b>	<b>1</b>	<b>C15</b>	<b>10</b>
<b>5 Mar 24</b>	<b>7</b>	<b>C16</b>	<b>25</b>

**11 (a)**

**Explain the purpose of query languages, both in general and with specific reference to SQL.**

**[2 marks]**

**(b) A local car club hires vehicles to its members by the hour. The club maintains records of its cars, members and monthly car hires in a relational database (opposite):**

**(i) Write an SQL command to output the Make and Model only of the electric cars. [2 marks]**

**(ii) Write an SQL command to output the Name of all members who hired a car on 3 Mar 24. [2 marks]**

**(Turn over)**

11 (b) (iii)

Another table is required to record car hire payments. Write an SQL command to create a new table called HirePayments to contain the following fields: [2 marks]

FIELD NAME	EXAMPLE DATA ENTRY
PaymentID	290
Date	3 Mar 24
MemberID	25
PaymentDue	60.00
Paid	TRUE

You do not need to add the data into the table.

12. Explain the main advantages and the associated security and integrity problems that may arise when using the cloud for storage, backup and online retrieval of files. [12 marks]

**END OF PAPER**