



GCE AS/A LEVEL

2420U20 – 1

WEDNESDAY, 22 MAY 2024 – AFTERNOON

**PHYSICS – AS UNIT 2
ELECTRICITY AND LIGHT**

1 hour 30 minutes plus your additional time allowance

Surname: _____

First name(s): _____

Centre Number: _____

Candidate Number: 2 _____

For Examiner's Use Only

Question	Maximum Mark	Mark Awarded
1.	6	
2.	7	
3.	14	
4.	9	
5.	9	
6.	6	
7.	10	
8.	8	
9.	11	
Total	80	

(Turn over)

ADDITIONAL MATERIALS

In addition to this paper you will require a calculator and a DATA BOOKLET.

ITEMS INCLUDED WITH QUESTION PAPER

A separate Diagram Booklet.

The Diagram Booklet **MUST** be handed in to the invigilators and sent for marking.

INSTRUCTIONS TO CANDIDATES

Use black ink, black ball – point pen, black felt tip or your usual method.

Write your name, centre number and candidate number in the spaces on the front cover.

Answer ALL questions.

Write your answers in the spaces provided. If you run out of space, use the additional page(s) at the back of this booklet, taking care to number the question(s) correctly.

(Turn over)

INFORMATION FOR CANDIDATES

The total number of marks available for this task is 80

The number of marks is given in brackets at the end of each question or part – question.

The assessment of the quality of extended response (QER) will take place in Question 6

(Turn over)

Question 1 continued

1. (b) Delyth tests this length of wire by placing it in the circuit shown in the diagram for Question 1 (b) in the separate Diagram Booklet.

Delyth concludes from the meter readings, shown on the diagram, that her resistor does NOT have a resistance of **56 Ω** . Evaluate whether or not this is a valid conclusion.

[3 marks]

(Total for Question 1 = 6 marks)

(Turn over)

2. (a) Refer to the series circuit in the diagram for Question 2 (a) in the separate Diagram Booklet. For the series circuit shown, write equations that give the relationships between:

(i) the currents (only);

[1 mark]

(ii) the potential differences (only).

[1 mark]

(b) Refer to the diagram for Question 2 (b) in the separate Diagram Booklet. The diagram shows a circuit that can produce a range of output pds, V_{out}

continued on the next page . . .

(Turn over)

Question 2 (b) continued

The middle resistor is a uniform carbon conductor, **XY**, of resistance **20 Ω** . A sliding contact, **S**, can be moved up and down, making contact with the conductor at any point along it.

2. (b) (i) Show clearly that when the sliding contact is at **Y**, **$V_{\text{out}} = 8.0 \text{ V}$** .

[2 marks]

- (ii) Determine the value of **V_{out}** when the sliding contact is at **X**.

[1 mark]

continued on the next page . . .

(Turn over)

Question 2 continued

2. (c) Refer to the diagram for Question 2 (c) in the separate Diagram Booklet. The circuit in (b) is to be modified to produce V_{out} ranging from 2 V to 10 V. The 12 V battery and the 20 Ω resistor with sliding contact are still to be used.

Design the new circuit, by giving the values for R_A and R_B .

[2 marks]

(Total for Question 2 = 7 marks)

(Turn over)

3. A battery has an emf of 12 V.

(a) (i) Explain what this statement means.

[2 marks]

(ii) State why it is usually a disadvantage for a battery to have an internal resistance.

[1 mark]

continued on the next page . . .

(Turn over)

Question 3 continued

3. (b) The battery is included in the circuit shown in the diagram for Question 3 (b) in the separate Diagram Booklet.

(i) Use the information shown on the circuit diagram to calculate:

I. the resistance, R .

[2 marks]

continued on the next page . . .

(Turn over)

Question 3 (b) (i) continued**II. the internal resistance, r .**

[2 marks]**3. (b) (ii) I. Calculate the energy transferred in the 20Ω resistor in 40 minutes.**

[2 marks]**continued on the next page . . .****(Turn over)**

Question 3 (b) (ii) continued

3. (b) (ii) II. State the energy transfer that occurs in the **20 Ω** resistor and explain, in terms of the motion of free electrons, how it takes place.

[2 marks]

- (iii) Dafydd claims that if **R** is replaced by a higher resistance, but no other changes are made, the power dissipation **IN THE 20 Ω RESISTOR** will increase. Evaluate this claim, showing clear reasoning.

(Turn over)

[3 marks]

(Total for Question 3 = 14 marks)

(Turn over)

4. (a) A progressive wave is travelling from left to right on a stretched string. A snapshot of the portion **XY** of the string at time $t = 0$ is shown in the diagram for Question 4 (a) in the separate Diagram Booklet.

(i) State the value of the wavelength.

[1 mark]

(ii) The periodic time is **100 ms**. Calculate the **SPEED** of the waves.

[2 marks]

continued on the next page . . .

(Turn over)

Question 4 (a) continued

4. (a) (iii) Refer to the blank grids provided for Question 4 (a) (iii) in the separate Diagram Booklet. Carefully sketch, on the grids the wave along **XY** at times **$t = 25 \text{ ms}$** and **$t = 50 \text{ ms}$** . A spare diagram is available for this question.

[2 marks]

- (b) If the string is attached to a fixed point to the right of **Y**, a stationary wave is observed on **XY**.

- (i) Explain how this stationary wave arises.

[2 marks]

continued on the next page . . .

(Turn over)

Question 4 (b) continued

4. (b) (ii) Refer to the diagram for Question 4 (b) (ii) in the separate Diagram Booklet.

The diagram shows **XY** at an instant (**$t = 0$**) when the stationary wave has maximum amplitude.

Refer to the blank grids provided for Question 4 (b) (ii) in the separate Diagram Booklet.

CAREFULLY SKETCH, on the grids, the wave along **XY** at times **$t = 25$ ms** and **$t = 50$ ms**.

[2 marks]

(Total for Question 4 = 9 marks)

(Turn over)

5. (a) Refer to the diagram of a two – slit set – up for Question 5 (a) in the separate Diagram Booklet. In the two – slit set – up shown, the centres of the bright fringes are 2.2 mm apart. S_1 and S_2 are slits with centres 0.45 mm apart, acting as in – phase sources.

(i) Explain the role of diffraction in producing the fringe pattern.

[2 marks]

continued on the next page . . .

(Turn over)

Question 5 (a) continued

5. (a) (ii) Calculate a value for the wavelength of the laser light.

[2 marks]

- (iii) Using your answer to (a)(ii) determine the path difference $S_2P - S_1P$ (see diagram 5 (a) in the separate Diagram Booklet), giving your reasoning.

(Turn over)

[3 marks]

5. (b) Give TWO reasons why a diffraction grating would be expected to give a more precise value for the wavelength than the two – slit method.

[2 marks]

(Total for Question 5 = 9 marks)

(Turn over)

6. State what is meant by 'unpolarised light' AND describe carefully how you would determine, using a polarising filter (polaroid), whether a light source is giving out polarised or unpolarised light.

7. Rhodri carries out an experiment to determine the refractive index, n , of a plastic in the form of a block of semi – circular cross – section. Refer to the diagram for Question 7 in the separate Diagram Booklet.

Rhodri places the block on paper and shines a narrow beam of light through the curved face, towards the circle centre. He measures angles θ_P and θ_A . He repeats the procedure for a range of angles of θ_P . His table of results is given on the next page, and his plot of $\sin \theta_A$ against $\sin \theta_P$ is shown in the graph for Question 7 in the Diagram Booklet.

continued on the next page . . .

Question 7 continued

$\theta_P (^\circ)$	$\sin \theta_P$	$\theta_A (^\circ)$	$\sin \theta_A$
0	0	0	0
5	0.087	8	0.139
10	0.174	16	0.276
15	0.259	25	0.423
20	0.342	34	0.559
25	0.423	42	0.669
30	0.500	54	0.809
35	_____	66	_____
40		—	

7. (a) State why no bending of the beam occurs as it enters the curved face of the block.

[1 mark]

continued on the next page . . .

(Turn over)

Question 7 continued

7. (b) **COMPLETE** the row of the table on the previous page for $\theta_P = 35^\circ$ **AND PLOT** the corresponding point on the graph in the Diagram Booklet. A spare graph is available for this question.

[2 marks]

- (c) (i) Discuss whether the graph supports the law that $\sin \theta_A$ is proportional to $\sin \theta_P$.

[3 marks]

continued on the next page . . .

(Turn over)

Question 7 (c) continued

7. (c) (ii) Determine a value for the refractive index, n .

[2 marks]

- (d) Rhodri could not obtain a value for θ_A when $\theta_P = 40^\circ$. Show why this had to be the case.

[2 marks]

(Total for Question 7 = 10 marks)

(Turn over)

8. (a) (i) State, IN TERMS OF ENERGY, the meanings of the two right – hand terms in Einstein’s photoelectric equation, shown below.

$$E_{k \text{ max}} = hf - \phi$$

I. hf

[1 mark]

II. ϕ

[1 mark]

continued on the next page . . .

(Turn over)

Question 8 (a) continued

8. (a) (ii) **Ultraviolet radiation of frequency 7.90×10^{14} Hz is shone on to surfaces of barium and magnesium in turn, using the apparatus shown in the diagram for Question 8 (a) (ii) in the separate Diagram Booklet.**

Determine whether or not electrons are emitted from each surface and, if so, the minimum pd needed to reduce the current shown by the microammeter to zero.

[Work function of barium = 4.03×10^{-19} J;

Work function of magnesium = 5.86×10^{-19} J]

(Turn over)

[3 marks]

8. (b) Photovoltaic panels transfer some of the energy from the Sun into electrical energy. It has been estimated that a quarter of the UK's electrical energy needs could be provided by photovoltaic panels covering an area equal to the total area of roofs on UK buildings. Discuss whether it should be compulsory to have photovoltaic panels on all roofs.

(Turn over)

[3 marks]

(Total for Question 8 = 8 marks)

(Turn over)

9. A simplified energy level diagram for a three – level laser is shown in the diagram for Question 9 in the separate Diagram Booklet.

(a) The laser emits light by means of stimulated emission involving levels **U** and **G**.

(i) Explain what is meant by stimulated emission involving levels **U** and **G**.

[2 marks]

(ii) State why there must be more electrons in **U** than in **G** for light amplification to occur.

[1 mark]

continued on the next page . . .

(Turn over)

Question 9 continued

9. (b) Calculate the wavelength of the light emitted by stimulated emission.

[3 marks]

- (c) The laser emits light at a power of **0.60 W**.

- (i) Show that approximately 2×10^{18} photons are emitted per second.

[1 mark]

continued on the next page . . .

(Turn over)

Question 9 (c) continued

9. (c) (ii) Calculate the magnitude of the momentum of an emitted photon.

[2 marks]

continued on the next page . . .

(Turn over)

Question 9 (c) continued

9. (c) (iii) The light from the laser strikes a shiny surface at right angles. Assuming that the surface reflects all the light, calculate the force exerted on the surface by the light.

[2 marks]

(Total for Question 9 = 11 marks)

TOTAL FOR PAPER = 80 MARKS

END OF PAPER

(Turn over)



GCE AS/A LEVEL

2420U20-1

WEDNESDAY, 22 MAY 2024 – AFTERNOON

**PHYSICS – AS UNIT 2
ELECTRICITY AND LIGHT**

**The Diagram Booklet MUST be handed in
to the invigilators and sent for marking.**

Diagram Booklet

Surname: _____

First name(s): _____

Centre Number: _____

Candidate Number: 2 _____

Question 1 (b)

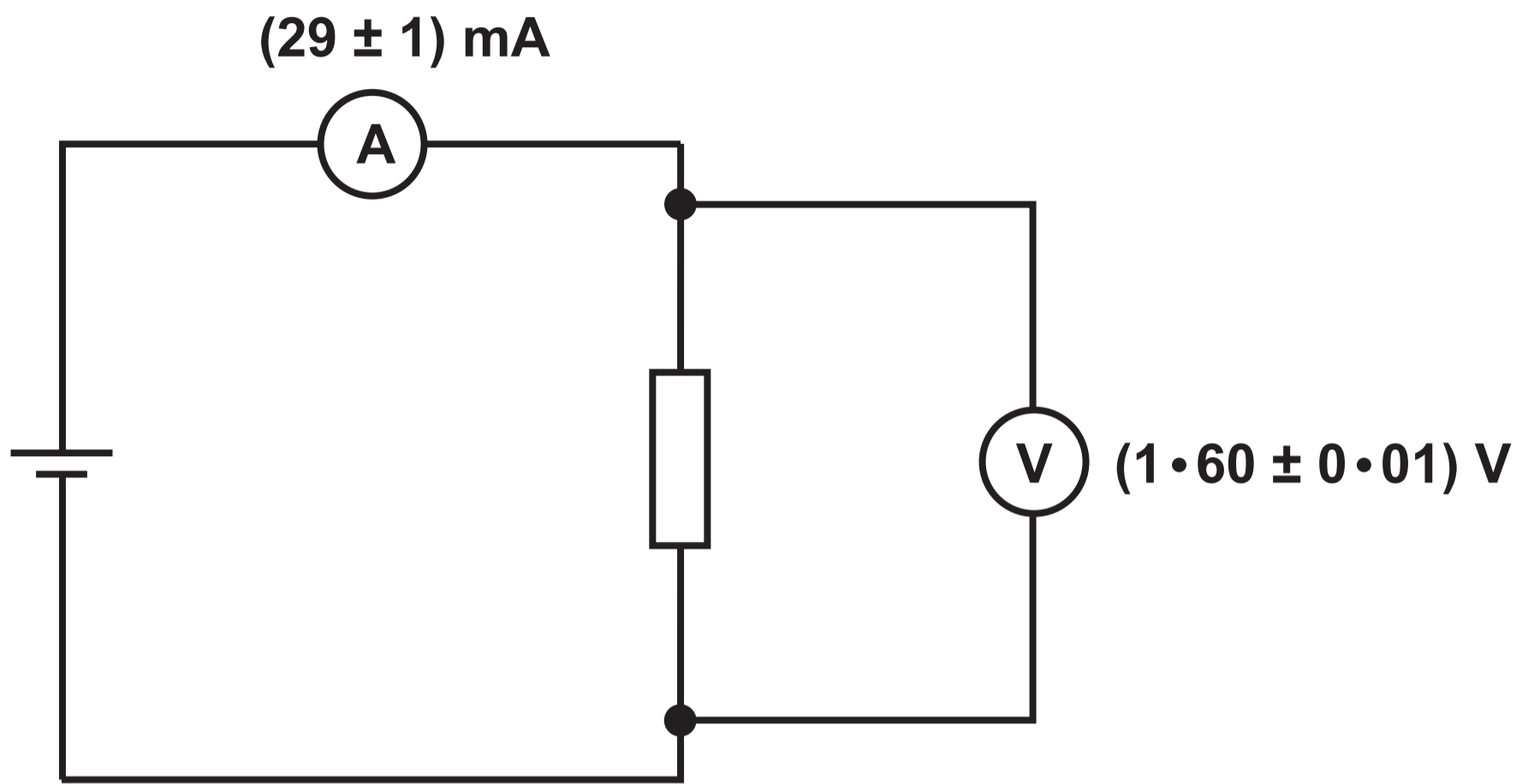

Question 2 (a)

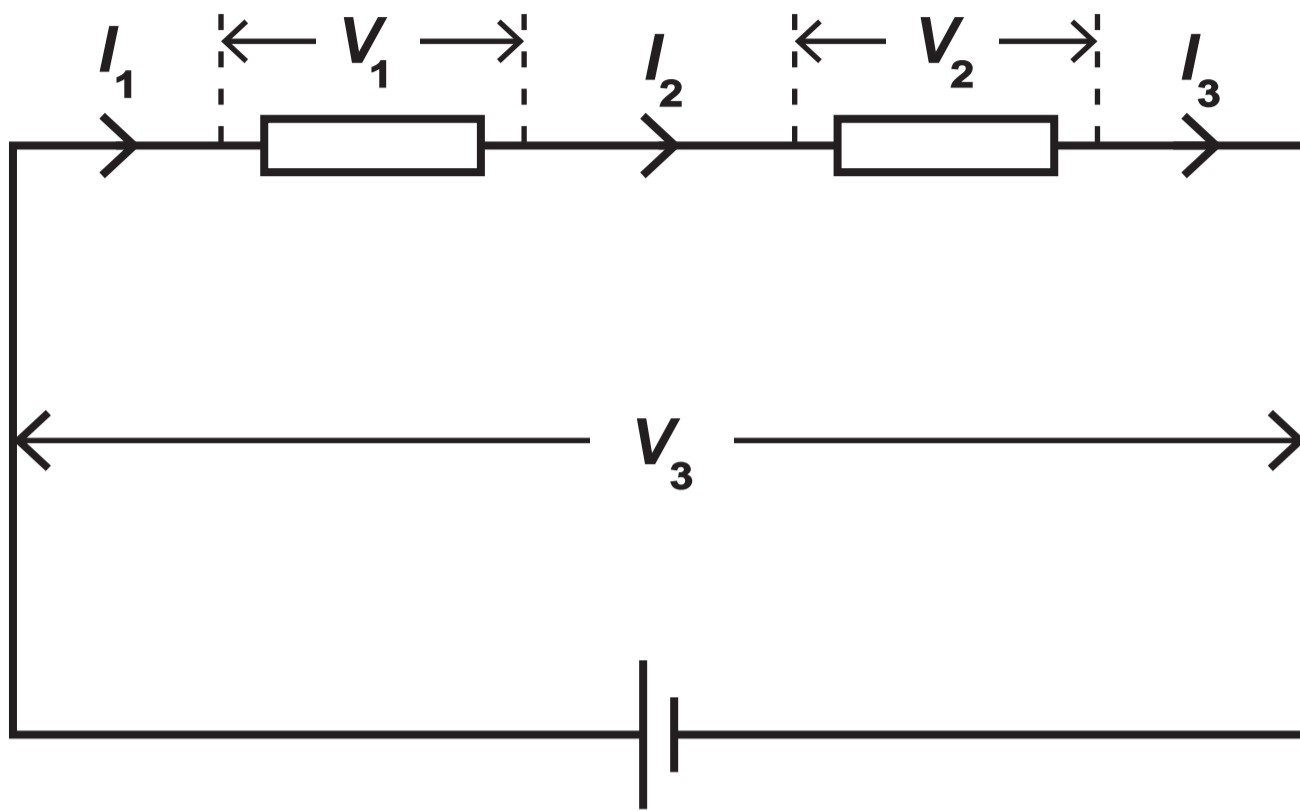

Question 2 (b)

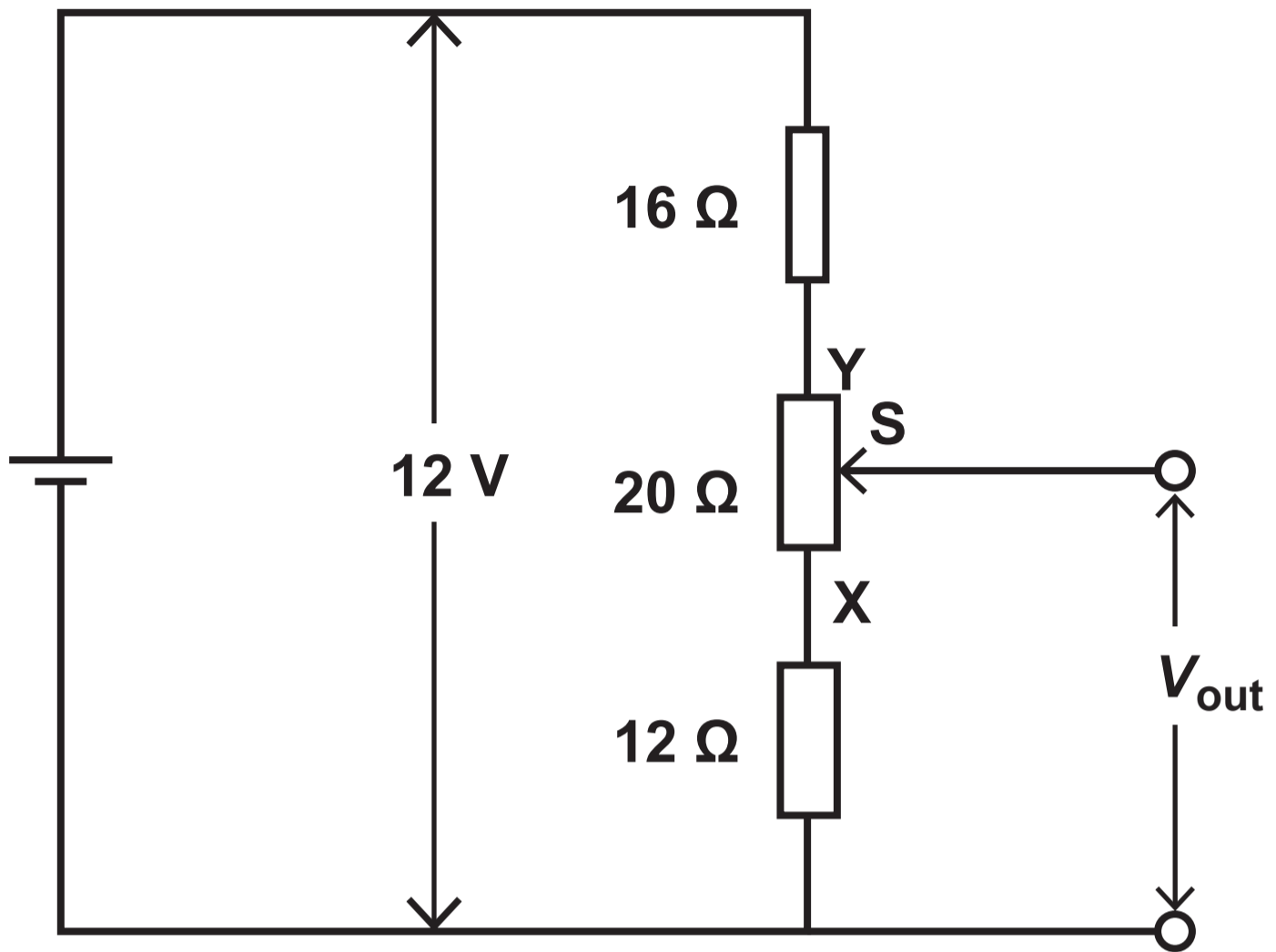

Question 2 (c)

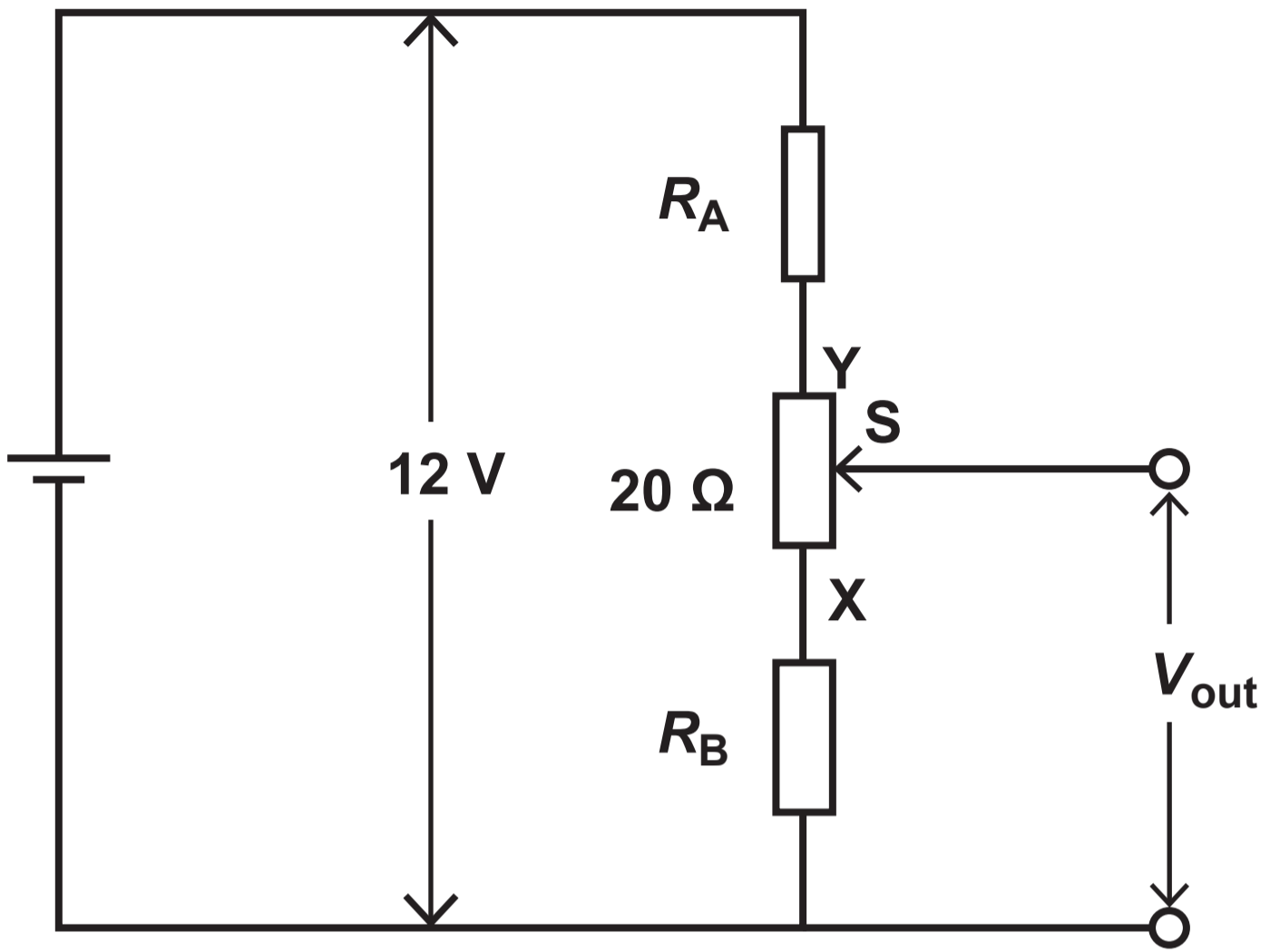

Question 3 (b)

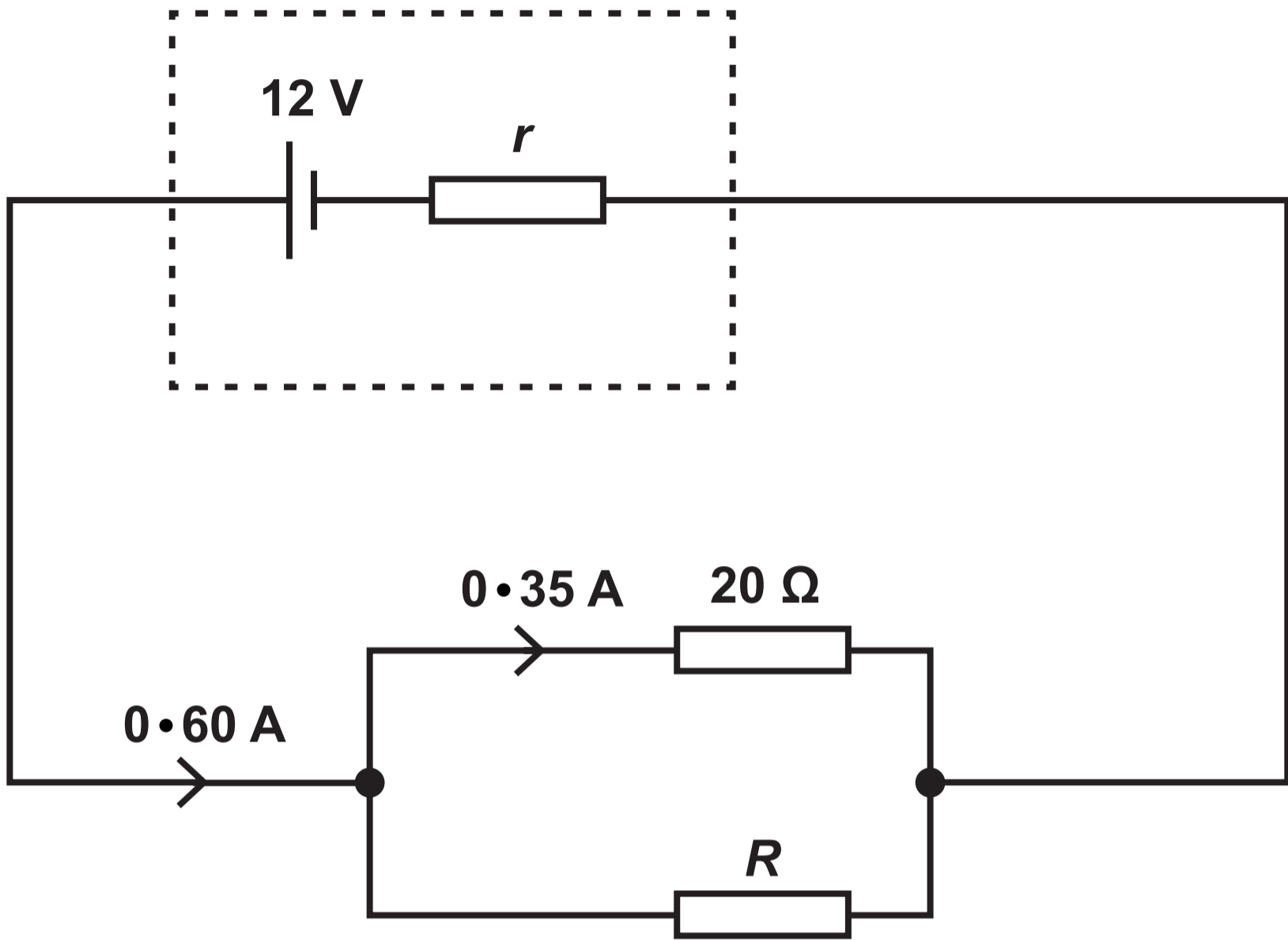

Question 4 (a)

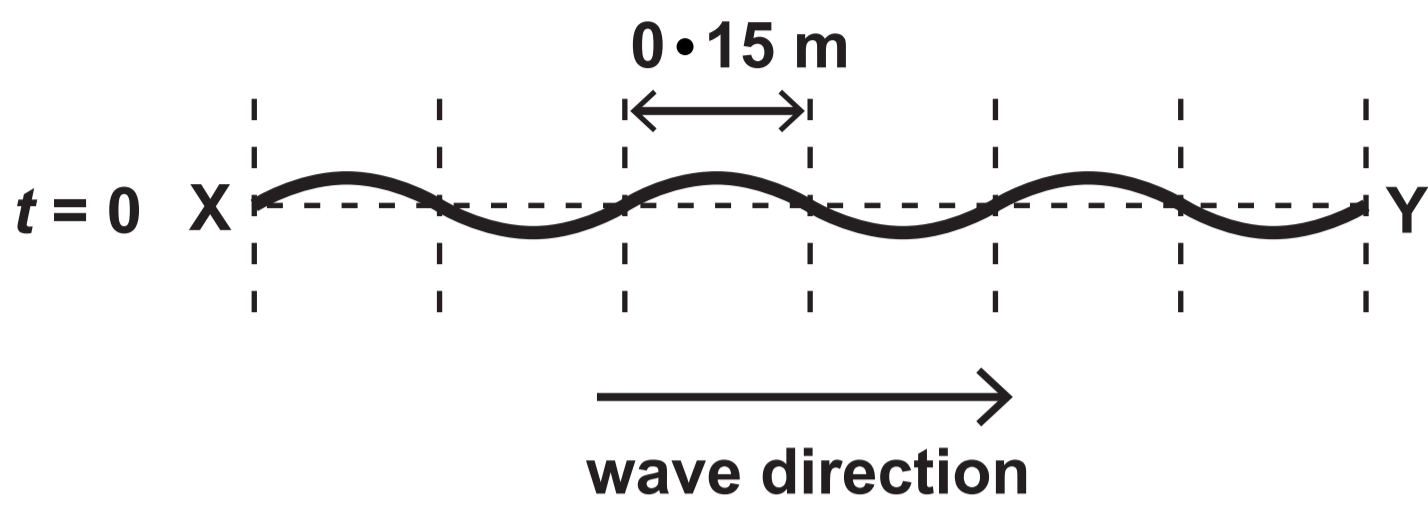

Question 4 (a) (iii)

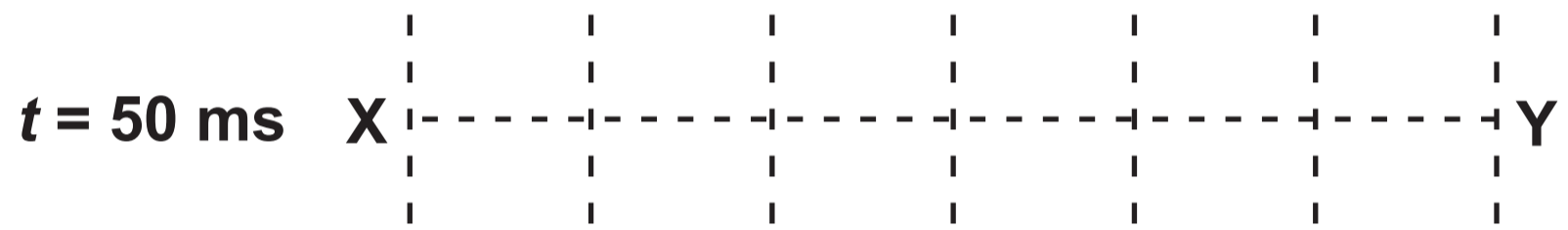
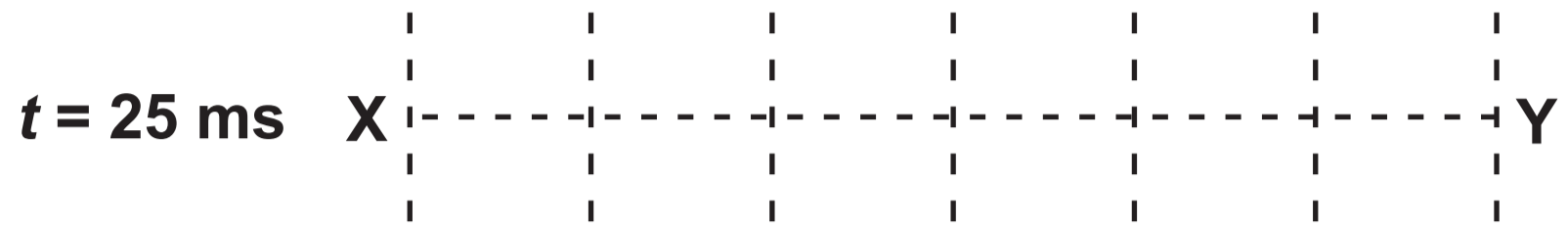

Spare copy

Question 4 (a) (iii)

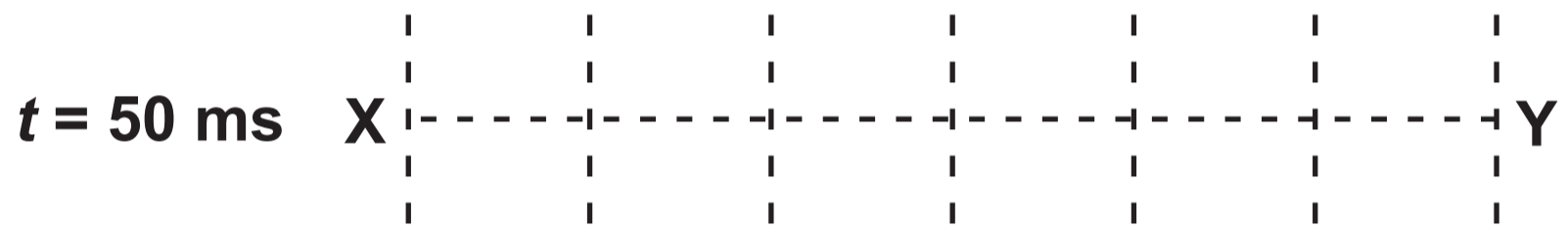
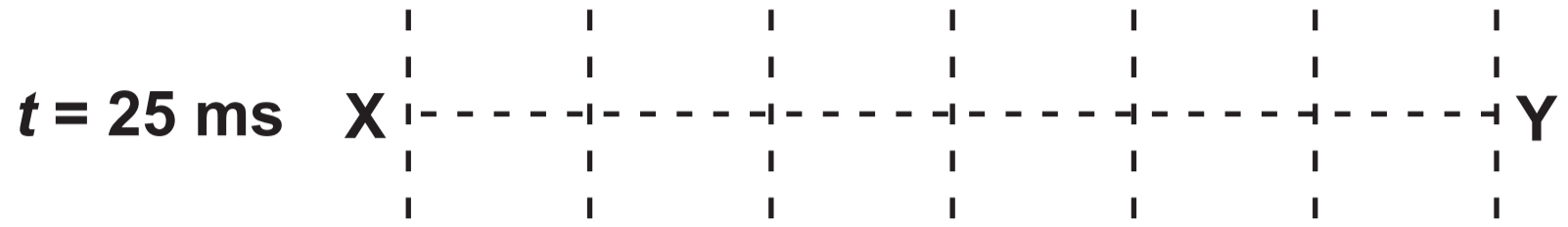

Question 4 (b) (ii)

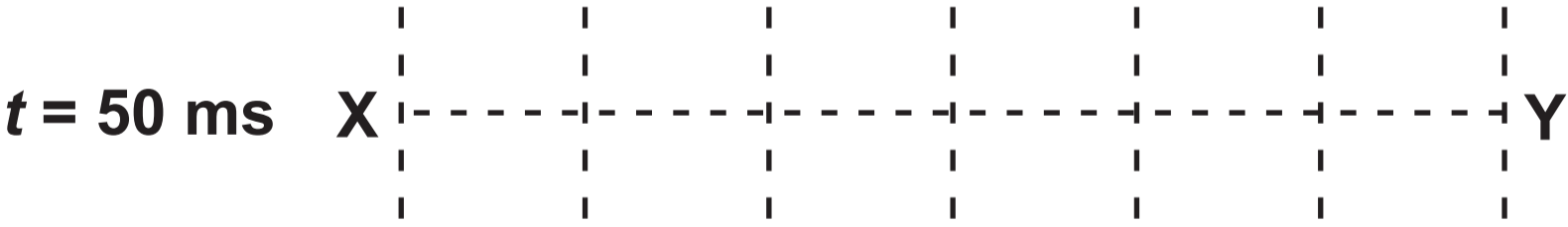
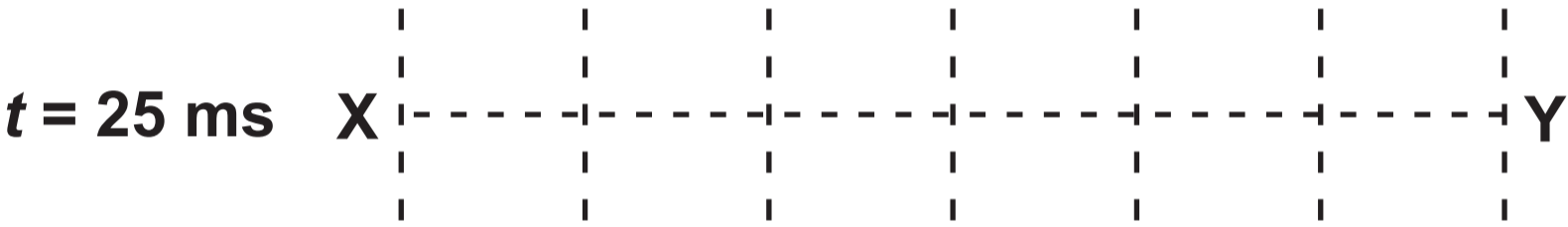
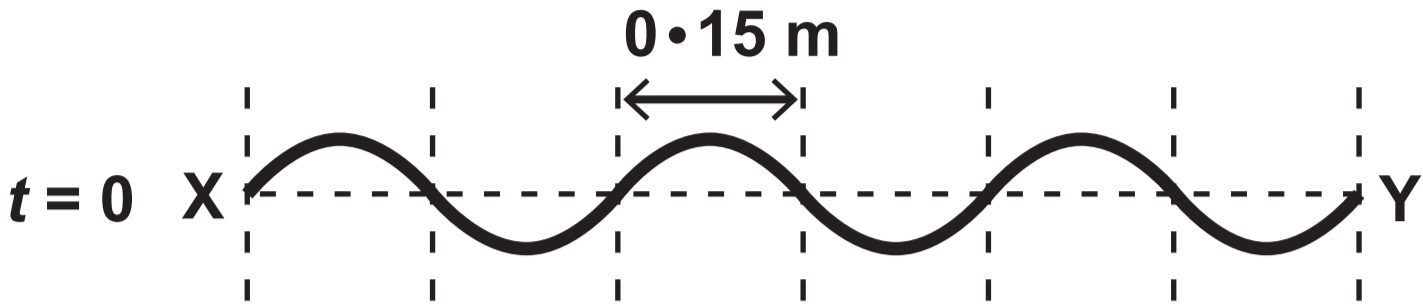

Question 5 (a)

DIAGRAM NOT DRAWN TO SCALE

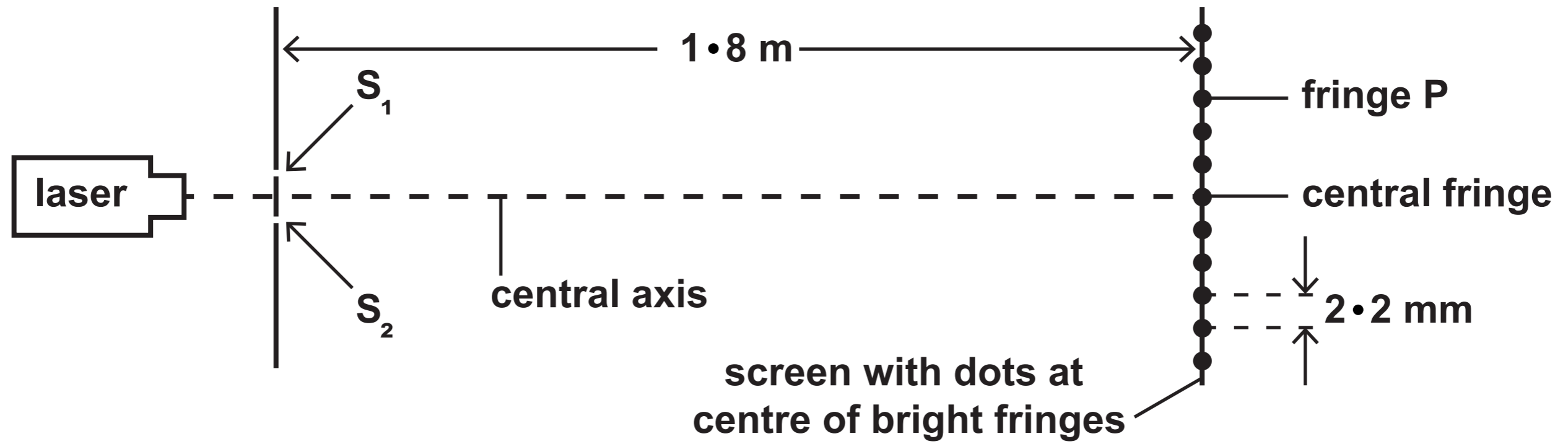

Question 7

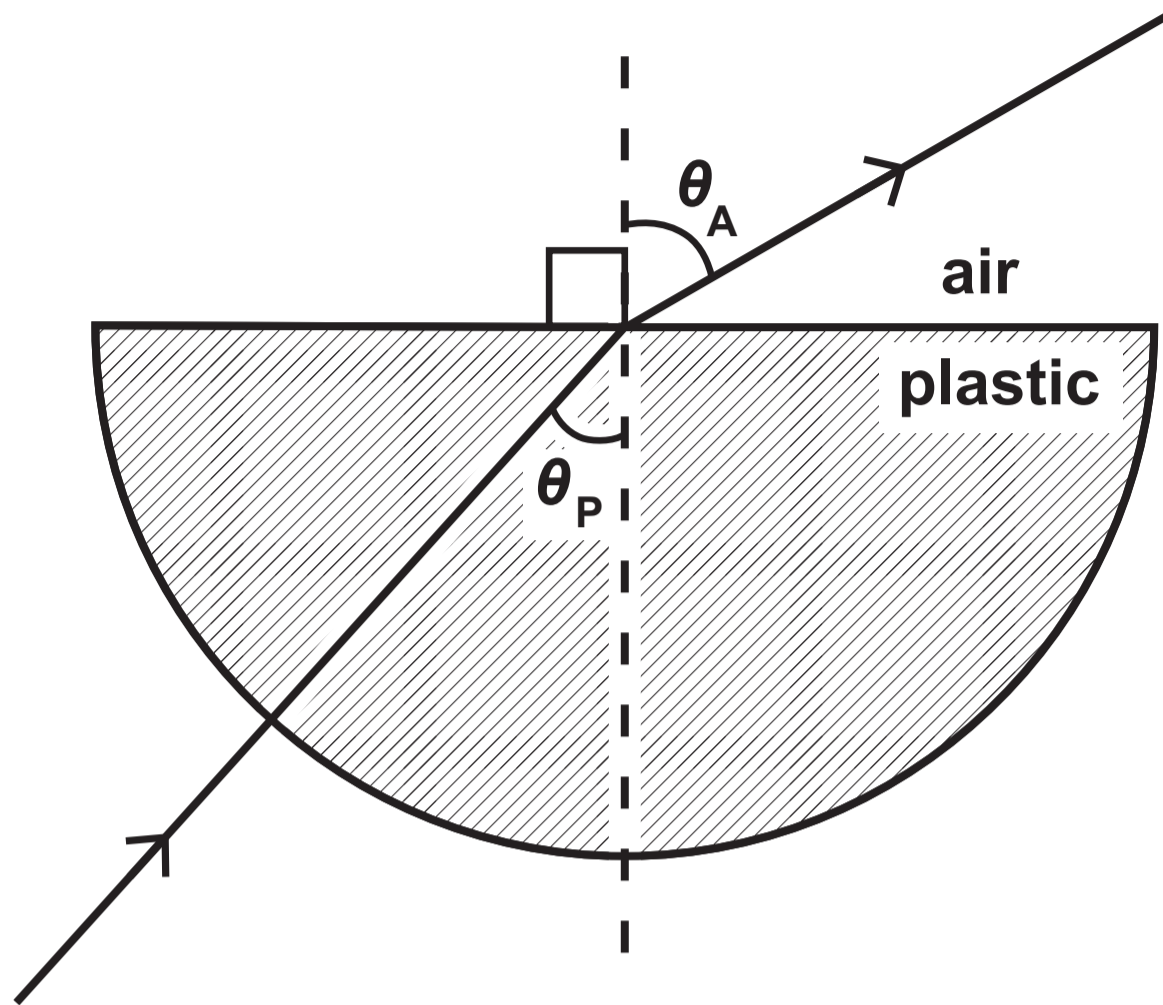

Question 7 (b)

GRAPH

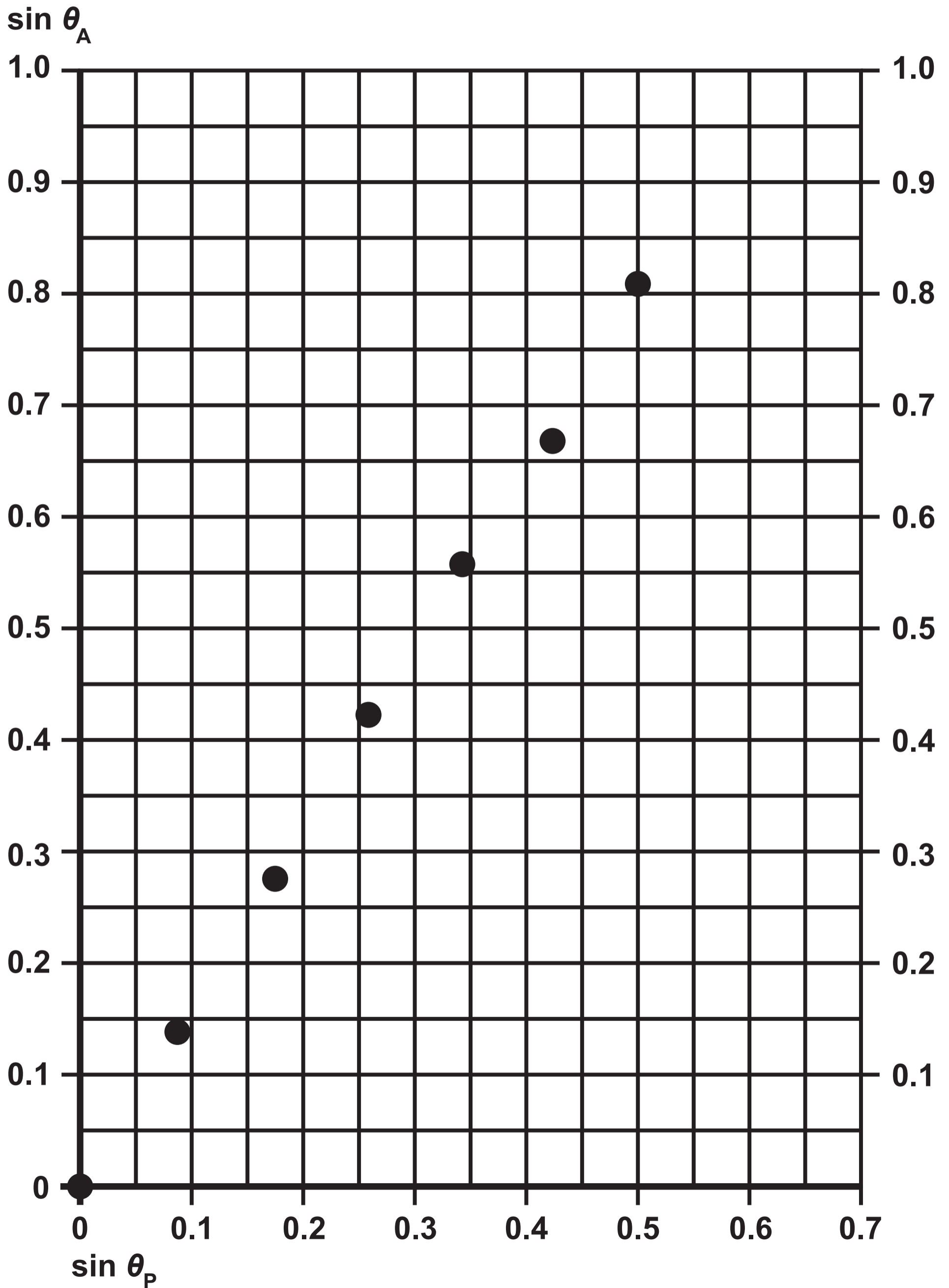

Spare copy

Question 7 (b)

GRAPH

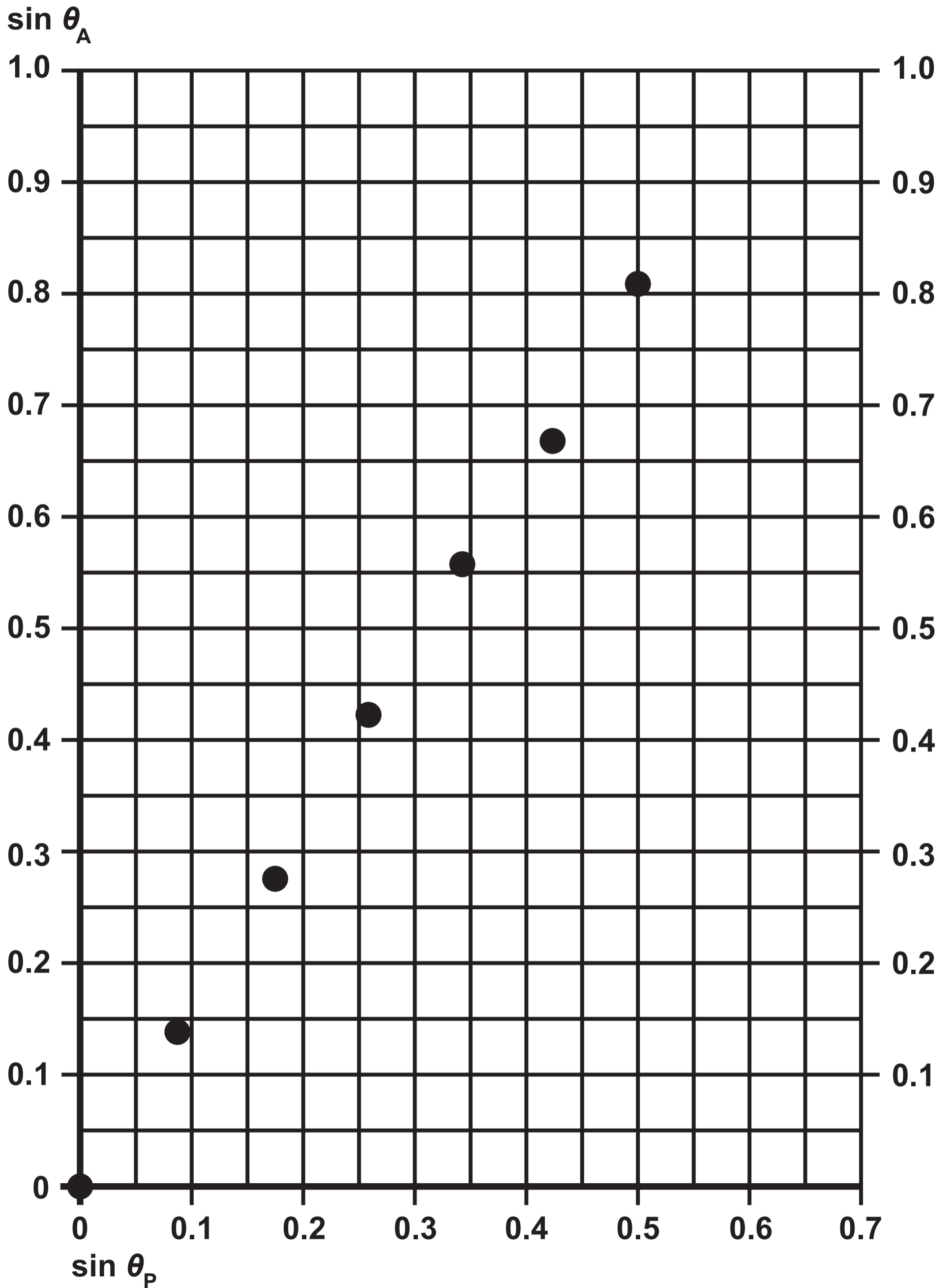

Question 8 (a) (ii)

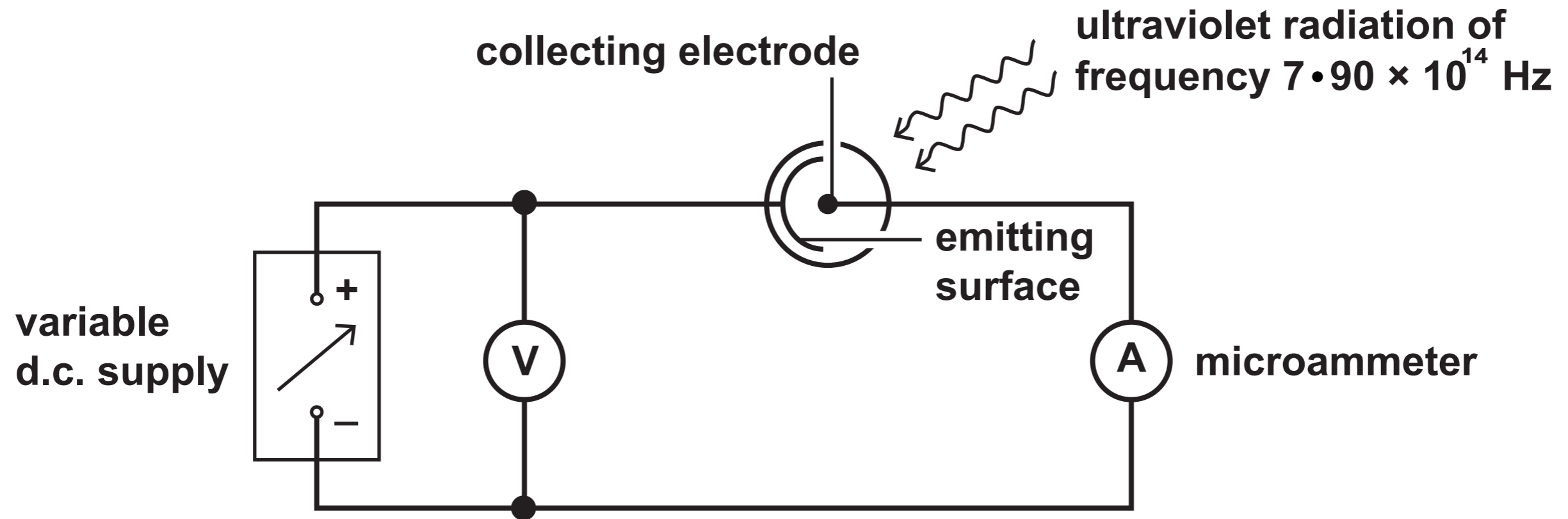

Question 9

P ————— **2.25 eV**

U ————— **1.79 eV**

G ————— **0**