

Surname	Centre Number	Candidate Number
First name(s)		0



GCSE

3603U10-1



TUESDAY, 18 JUNE 2024 – MORNING

DESIGN AND TECHNOLOGY

**Unit 1
PRODUCT DESIGN**

2 hours

For Examiner's use only		
Question	Maximum Mark	Mark Awarded
1.	15	
2.	10	
3.	25	
4.	20	
5.	10	
6.	20	
Total	100	

ADDITIONAL MATERIALS

In addition to this examination paper, you will need a calculator.

INSTRUCTIONS TO CANDIDATES

Use black ink or black ball-point pen. Do not use gel pen or correction fluid.

You may use a pencil for diagrams only.

Write your name, centre number and candidate number in the spaces at the top of this page.

Answer **all** questions.

Write your answers in the spaces provided in this booklet. If you run out of space, use the additional page at the back of the booklet, taking care to number the question(s) correctly.

INFORMATION FOR CANDIDATES

The number of marks is given in brackets at the end of each question or part-question. You are advised to divide your time accordingly.

The total number of marks available is 100.

You are reminded of the need for good English and orderly, clear presentation in your answers.

The quality of your written communication, including appropriate use of punctuation and grammar, will be assessed in your answer to question **5(b)**.



JUN243603U10101

Answer **all** questions.

1. The image below shows greener take-away food containers and cutlery. It consists of wax-lined cardboard boxes and cutlery made from compostable materials.



- (a) (i) Explain how the compostable cutlery can be considered greener. [2]

.....

.....

.....

- (ii) The food containers are made from cardboard which has a waxed coating applied to the inside. Describe the reason for the waxed coating. [3]

.....

.....

.....





- (b) (i) The food containers have been mass produced using die cutting. Explain in detail how the die cutting process is suitable for producing the food containers. [4]

.....

.....

.....

.....

.....

.....

- (ii) Describe the reason for the packaging feature shown below, labelled A. [2]

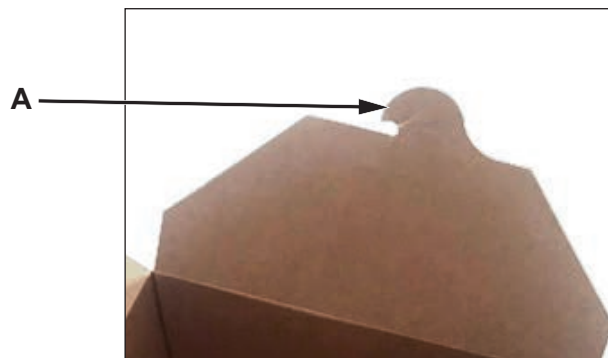

.....

.....

.....



(c) The stainless steel drinking straw shown below is extendable and fits into a casing.



Explain how the stainless steel drinking straw provides a greener solution to a worldwide problem.

[4]

.....

.....

.....

.....

.....

.....



BLANK PAGE

**PLEASE DO NOT WRITE
ON THIS PAGE**



2. The two chairs shown below have been produced using Life Cycle Analysis as a design strategy.



Chair A

Made from used bicycle wheels and tyres
Retail price £189



Chair B

Made from worn car tyres and seat belts
Retail price £229

(a) Chair A has been designed for teenage cyclists. Explain how Chair A will appeal to this target market. [2]

.....

.....

.....

(b) Explain how Chair B provides an economic benefit to the manufacturer. [3]

.....

.....

.....

.....



(c) Describe how the Life Cycle Analysis strategy has been used to design and develop Chair A and Chair B. [5]

.....

.....

.....

.....

.....

.....

.....

.....

3603U101
07



3. The space-saving clothes dryer shown below can be wall mounted indoors or outdoors.

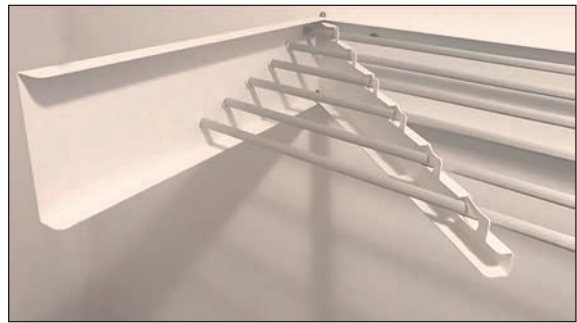

Product information:

- Mild steel body that opens and closes.
- 6 × aluminium clothes bars.
- Steel wings that keep aluminium bars parallel.
- Stainless steel M5 bolts, washers and locking nuts used as a hinge.
- Product weight 4 kg.
- Safety tested to hang up to 3 kg of clothing per bar.
- Magnet fitted to the inside of the back of the clothes dryer.

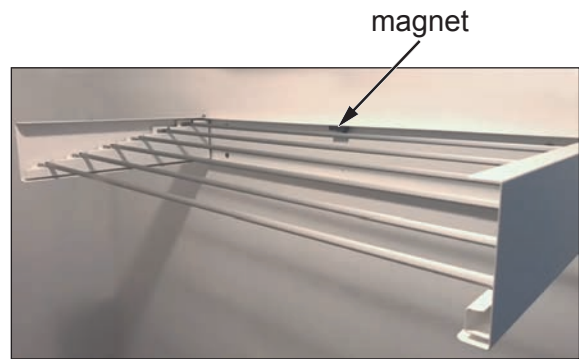

(a) (i) Give **two** reasons why mild steel is a suitable material for the body of the clothes dryer. 2 × [2]

Reason 1:

.....

.....

Reason 2:

.....

.....

(ii) Explain why a magnet is fitted to the back of the clothes dryer. [2]

.....

.....

.....



(iii) The mild steel body parts have a paint finish applied. Describe **two** advantages this gives the clothes dryer. 2 × [2]

Advantage 1:

.....
.....

Advantage 2:

.....
.....

(b) The image below shows the steel wings that hold each aluminium bar with a 'U'-shaped feature.

'U'-shaped feature

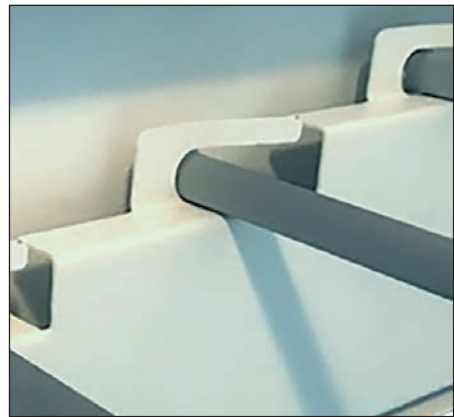
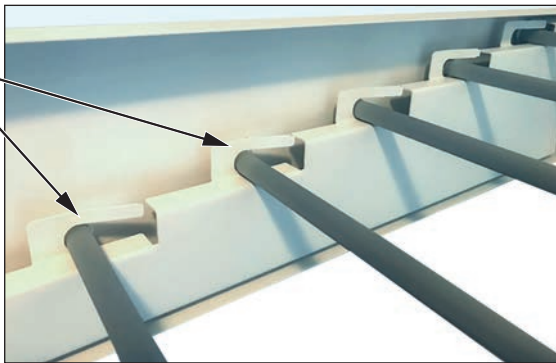

Enlarged view of 'U'-shaped feature

(i) Explain why the 'U'-shaped feature is necessary, and what would happen if this was not present. [4]

.....
.....
.....
.....
.....
.....

3603U101
09



- (ii) During manufacture, the mild steel parts have been pressed from a sheet and deformed using a bending jig.
Explain **two** benefits of using a bending jig during the manufacturing process.

2 × [2]

Benefit 1:

.....

Benefit 2:

.....

- (c) The aluminium bars have a grooved finish as shown below.

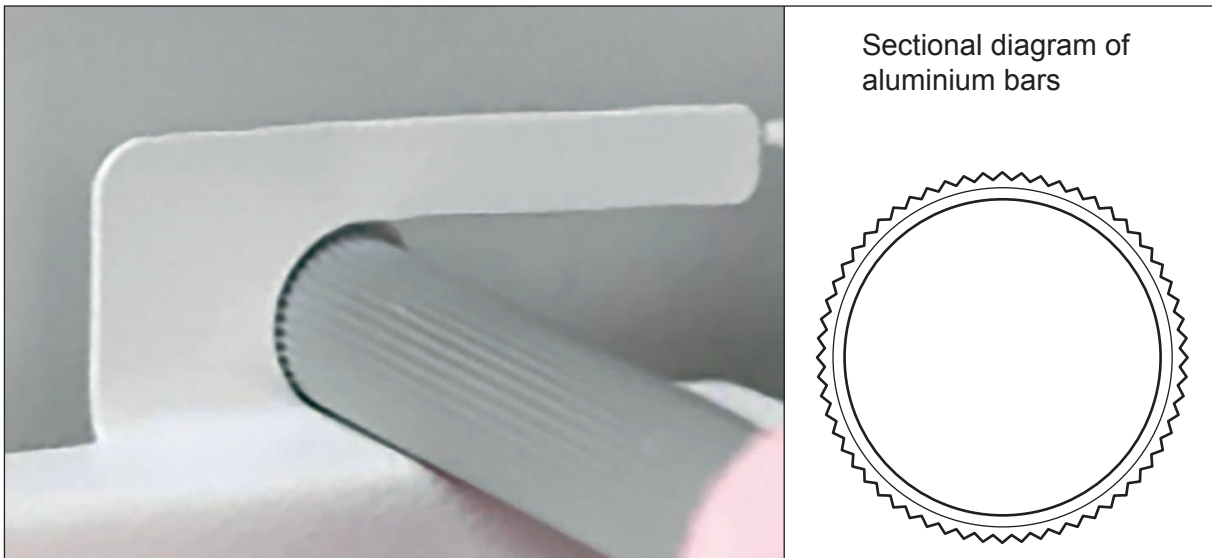

- (i) Explain how the grooved finish has improved the performance of the aluminium bars. [3]

.....

.....

.....

.....

.....



(ii) Each aluminium bar has been tested and guaranteed to hold up to 3 kg of clothing. Describe how this could influence sales. [2]

.....

.....

.....

(d) A locking nut is used at the top and bottom of each side of the clothes dryer.



Describe why a locking nut has been used. [2]

.....

.....

.....

3603U101
11



4. The water bottles shown below include a fruit infuser to allow users to flavour the water they consume.



Product information:

- 650 ml capacity
- Sports cap with spill-proof lid
- Bottle is made from recycled polymer
- Various colours available



Check out our **45** reviews



All products are 100% officially certified.

(a) (i) Describe **one** way that the bottle can be considered ergonomic. [2]

.....

.....

.....

(ii) Explain how providing a variety of colours benefits the manufacturer. [2]

.....

.....

.....

(iii) The website where bottles can be purchased includes the 'Officially Certified' logo. Explain how this may influence potential consumers. [3]

.....

.....

.....

.....

.....



(iv) Explain the reasons the website encourages purchasers to review the product through Trustpilot. [3]

.....

.....

.....

.....

.....

(b) During the development stages of the water bottle, a number of rapid prototypes were produced for the sports cap, two of which are shown below.



(i) Analyse why the design team would produce a range of different sports caps during the development stages. [5]

.....

.....

.....

.....

.....

.....

.....

.....

.....

.....



(ii) An additive manufacturing process was used to create the sports caps shown. Evaluate the benefits of additive manufacturing processes. [5]

.....

.....

.....

.....

.....

.....

.....

.....

.....

.....



BLANK PAGE

**PLEASE DO NOT WRITE
ON THIS PAGE**



5. The modern smart home device shown below was designed to reflect user-centred design.



(a) Analyse the meaning of user-centred design and how this has influenced the smart home device. [5]

.....

.....

.....

.....

.....

.....

.....

.....

.....

.....

(b) The images show two accessories that can be controlled using the smart home device.



Smart plug



Smart light bulb

Evaluate how the ability to control multiple home accessories provides an innovative solution. [5]

Marks will be awarded for the content of the answer and the quality of written communication.

.....

.....

.....

.....

.....

.....

.....

.....



6. The portable tray below is designed for carrying refreshments and can securely fit onto most types of furniture.

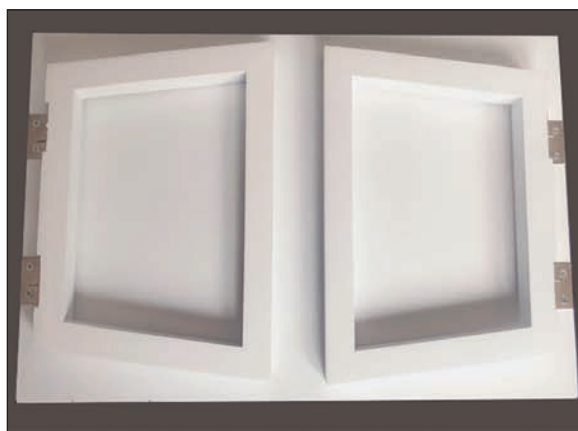

- (a) (i) The four sides of the tray are made from medium density fibreboard (MDF). Describe **two** properties of MDF that make it suitable for the sides of the tray.

2 × [2]

Property 1:

.....

.....

Property 2:

.....

.....



- (ii) The legs of the tray are constructed using a dowelled butt joint. In the space below, produce a labelled sketch showing how you would manufacture a dowelled butt joint. [4]

- (b) The legs of the tray are hinged as shown below.



- (i) Explain the role of the spring fitted to the centre of the hinge. [3]

.....

.....

.....

.....

.....



The photograph below shows the tray disassembled.

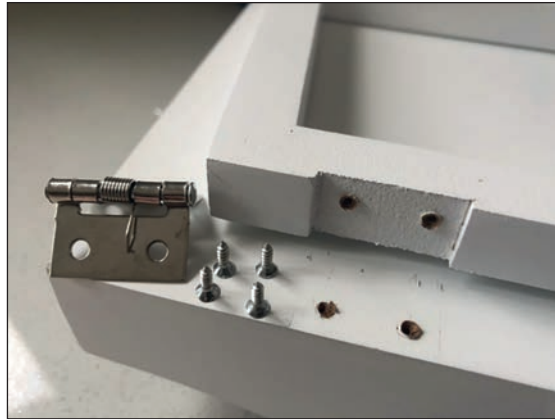

(ii) Explain the reason for the four pilot holes. [2]

.....

.....

.....

(iii) The hinges and screws are bought-in components. Explain how this benefits the manufacturer when producing the tray using high volume production. [4]

.....

.....

.....

.....

.....

.....



(c) The CAD drawing is used to manufacture the tray handles using a CAM router as shown below.

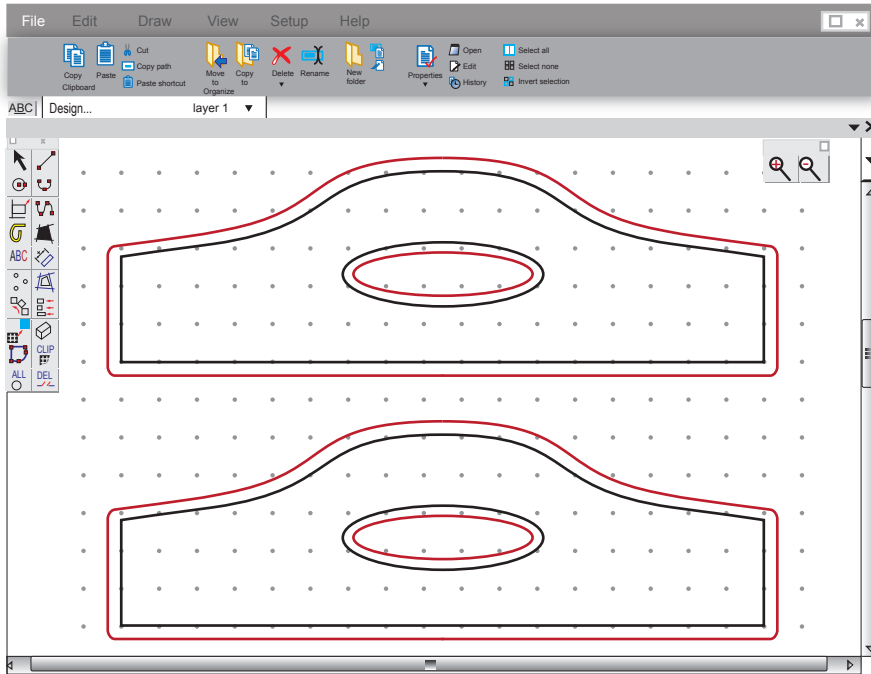

CAD drawing

CAM router

Explain the difference between the red and black lines on the CAD drawing when manufacturing the tray handles using the CAM router.

[3]

.....

.....

.....

.....

END OF PAPER



BLANK PAGE

**PLEASE DO NOT WRITE
ON THIS PAGE**



BLANK PAGE

**PLEASE DO NOT WRITE
ON THIS PAGE**

