



GCSE MARKING SCHEME

SUMMER 2024

**GCSE
ELECTRONICS – COMPONENT 1
C490UA0-1**

About this marking scheme

The purpose of this marking scheme is to provide teachers, learners, and other interested parties, with an understanding of the assessment criteria used to assess this specific assessment.

This marking scheme reflects the criteria by which this assessment was marked in a live series and was finalised following detailed discussion at an examiners' conference. A team of qualified examiners were trained specifically in the application of this marking scheme. The aim of the conference was to ensure that the marking scheme was interpreted and applied in the same way by all examiners. It may not be possible, or appropriate, to capture every variation that a candidate may present in their responses within this marking scheme. However, during the training conference, examiners were guided in using their professional judgement to credit alternative valid responses as instructed by the document, and through reviewing exemplar responses.

Without the benefit of participation in the examiners' conference, teachers, learners and other users, may have different views on certain matters of detail or interpretation. Therefore, it is strongly recommended that this marking scheme is used alongside other guidance, such as published exemplar materials or Guidance for Teaching. This marking scheme is final and will not be changed, unless in the event that a clear error is identified, as it reflects the criteria used to assess candidate responses during the live series.

GCSE ELECTRONICS
COMPONENT 1 – DISCOVERING ELECTRONICS
SUMMER 2024 MARK SCHEME
GENERAL INSTRUCTIONS

Recording of marks

Examiners must mark in red ink.

One tick must equate to one mark (except for the extended response question).

Question totals should be written in the box at the end of the question.

Question totals should be entered onto the grid on the front cover and these should be added to give the script total for each candidate.

Marking rules

All work should be seen to have been marked.

Marking schemes will indicate when explicit working is deemed to be a necessary part of a correct answer.

Crossed out responses not replaced should be marked.

Credit will be given for correct and relevant alternative responses which are not recorded in the mark scheme.

Extended response question

A level of response mark scheme is used. Before applying the mark scheme please read through the whole answer from start to finish. Firstly, decide which level descriptor matches best with the candidate's response: remember that you should be considering the overall quality of the response. Then decide which mark to award within the level. Award the higher mark in the level if there is a good match with both the content statements and the communication statement.

Marking abbreviations

The following may be used in marking schemes or in the marking of scripts to indicate reasons for the marks awarded.

cao = correct answer only

ecf = error carried forward

Question			Marking details			Marks available																			
						AO1	AO2	AO3	Total	Maths															
1	a	(i)	B			1	0	0	1	0															
		(ii)	E			1	0	0	1	0															
	b	(i)	F			1	0	0	1	0															
		(ii)	C			1	0	0	1	0															
	c	(i)	<table border="1"> <thead> <tr> <th>B</th> <th>A</th> <th>Q</th> </tr> </thead> <tbody> <tr> <td>0</td> <td>0</td> <td>1</td> </tr> <tr> <td>0</td> <td>1</td> <td>1</td> </tr> <tr> <td>1</td> <td>0</td> <td>1</td> </tr> <tr> <td>1</td> <td>1</td> <td>0</td> </tr> </tbody> </table>			B	A	Q	0	0	1	0	1	1	1	0	1	1	1	0	1	0	0	1	0
			B	A	Q																				
0	0	1																							
0	1	1																							
1	0	1																							
1	1	0																							
(ii)	<table border="1"> <thead> <tr> <th>B</th> <th>A</th> <th>Q</th> </tr> </thead> <tbody> <tr> <td>0</td> <td>0</td> <td>1</td> </tr> <tr> <td>0</td> <td>1</td> <td>0</td> </tr> <tr> <td>1</td> <td>0</td> <td>0</td> </tr> <tr> <td>1</td> <td>1</td> <td>0</td> </tr> </tbody> </table>			B	A	Q	0	0	1	0	1	0	1	0	0	1	1	0	1	0	0	1	0		
	B	A	Q																						
0	0	1																							
0	1	0																							
1	0	0																							
1	1	0																							
Question 1 total			6	0	0	6	0																		

Question		Marking details	Marks available																						
			AO1	AO2	AO3	Total	Maths																		
2	a	<table border="1"> <thead> <tr> <th>Input sub-systems</th> <th>Processing sub-systems</th> <th>Output sub-systems</th> </tr> </thead> <tbody> <tr> <td>Moisture sensing unit</td> <td>AND gate</td> <td>Motor unit</td> </tr> <tr> <td>Light sensing unit</td> <td>Transducer Driver</td> <td>Lamp unit</td> </tr> <tr> <td>Pressure sensing unit</td> <td>Latch unit</td> <td></td> </tr> <tr> <td></td> <td>NOR Gate</td> <td></td> </tr> <tr> <td></td> <td></td> <td></td> </tr> </tbody> </table> <p>1 mark per correct column</p>	Input sub-systems	Processing sub-systems	Output sub-systems	Moisture sensing unit	AND gate	Motor unit	Light sensing unit	Transducer Driver	Lamp unit	Pressure sensing unit	Latch unit			NOR Gate					3	0	0	3	0
		Input sub-systems	Processing sub-systems	Output sub-systems																					
Moisture sensing unit	AND gate	Motor unit																							
Light sensing unit	Transducer Driver	Lamp unit																							
Pressure sensing unit	Latch unit																								
	NOR Gate																								
2	b	<p>1 mark for each correct box</p>	0	4	3	7	0																		
		Question 2 total	3	4	3	10	0																		

Question			Marking details	Marks available					
				AO1	AO2	AO3	Total	Maths	
3	a	(i)	Red (1) Black (1) Brown (1) Silver	3	0	0	3	0	
		(ii)	$P = I^2 R$ (1 Equation) $P = (20 \times 10^{-3})^2 \times 200$ (1 – Substitution) $P = 0.08 \text{ W} = 80 \text{ mW}$ (1 – Answer)	1	2	0	3	2	
	b	(i)	$I_2 = 60 - 20 = 40 \text{ mA}$	0	1	0	1	1	
			$I_3 = 20 + 40 = 60 \text{ mA}$	0	1	0	1	1	
		(ii)	$V = IR$ (1 – Formula) $V_1 = I_1 \times R_1$ $V_1 = 20 \text{ mA} \times 200$ (1 – Substitution) $V_1 = 4 \text{ V}$ (1 – Answer)	1	2	0	3	3	
		(iii)	$V_2 = 4 \text{ V}$ ecf b(ii)	0	1	0	1	1	
			$V_3 = 10 - 4 = 6 \text{ V}$ ecf	0	1	0	1	1	
		(iv)	$V = IR$ (ecf (b(i) & b(iii))) $R_2 = \frac{V_2}{I_2}$ (1 – rearrangement) $R_2 = \frac{4}{40 \text{ mA}}$ (1 – substitution) $R_2 = 100 \Omega$ (1 – answer)	1	2	0	3	3	
	Question 3 total				6	10	0	16	12

Question			Marking details				Marks available																																																																	
							AO1	AO2	AO3	Total	Maths																																																													
4	a	(i)	<table border="1"> <thead> <tr> <th colspan="2">Inputs</th> <th>Output</th> </tr> <tr> <th>A</th> <th>A</th> <th>Q</th> </tr> </thead> <tbody> <tr> <td>0</td> <td>0</td> <td>1</td> </tr> <tr> <td>0</td> <td>1</td> <td>0</td> </tr> <tr> <td>1</td> <td>0</td> <td>0</td> </tr> <tr> <td>1</td> <td>1</td> <td>0</td> </tr> </tbody> </table>				Inputs		Output	A	A	Q	0	0	1	0	1	0	1	0	0	1	1	0	0	1	0	1	0																																											
		Inputs		Output																																																																				
	A	A	Q																																																																					
0	0	1																																																																						
0	1	0																																																																						
1	0	0																																																																						
1	1	0																																																																						
(ii)	NOT Gate / Inverter				0	1	0	1	0																																																															
b	<table border="1"> <thead> <tr> <th>C</th> <th>B</th> <th>A</th> <th>D</th> <th>E</th> <th>F</th> <th>Q</th> </tr> </thead> <tbody> <tr> <td>0</td> <td>0</td> <td>0</td> <td>1</td> <td>1</td> <td>0</td> <td>0</td> </tr> <tr> <td>0</td> <td>0</td> <td>1</td> <td>0</td> <td>1</td> <td>0</td> <td>0</td> </tr> <tr> <td>0</td> <td>1</td> <td>0</td> <td>1</td> <td>0</td> <td>1</td> <td>1</td> </tr> <tr> <td>0</td> <td>1</td> <td>1</td> <td>0</td> <td>0</td> <td>1</td> <td>0</td> </tr> <tr> <td>1</td> <td>0</td> <td>0</td> <td>1</td> <td>1</td> <td>0</td> <td>0</td> </tr> <tr> <td>1</td> <td>0</td> <td>1</td> <td>0</td> <td>1</td> <td>0</td> <td>0</td> </tr> <tr> <td>1</td> <td>1</td> <td>0</td> <td>1</td> <td>0</td> <td>0</td> <td>0</td> </tr> <tr> <td>1</td> <td>1</td> <td>1</td> <td>0</td> <td>0</td> <td>0</td> <td>0</td> </tr> </tbody> </table> <p>1 mark for each correct column. ecf for F & Q</p>				C	B	A	D	E	F	Q	0	0	0	1	1	0	0	0	0	1	0	1	0	0	0	1	0	1	0	1	1	0	1	1	0	0	1	0	1	0	0	1	1	0	0	1	0	1	0	1	0	0	1	1	0	1	0	0	0	1	1	1	0	0	0	0	4	0	0	4	0
C	B	A	D	E	F	Q																																																																		
0	0	0	1	1	0	0																																																																		
0	0	1	0	1	0	0																																																																		
0	1	0	1	0	1	1																																																																		
0	1	1	0	0	1	0																																																																		
1	0	0	1	1	0	0																																																																		
1	0	1	0	1	0	0																																																																		
1	1	0	1	0	0	0																																																																		
1	1	1	0	0	0	0																																																																		

Question			Marking details	Marks available				
				AO1	AO2	AO3	Total	Maths
4	c	(i)		4	0	0	4	0
		(ii)	<p>1 Pair of redundant gates identified = 1 mark</p>	0	1	0	1	0

Question			Marking details	Marks available				
				AO1	AO2	AO3	Total	Maths
4	c	(iii)	Converting a logic circuit to NAND gates only reduces the number of logic IC's / reduce the overall cost of the system.	0	1	0	1	0
			Question 4 total	8	4	0	12	0

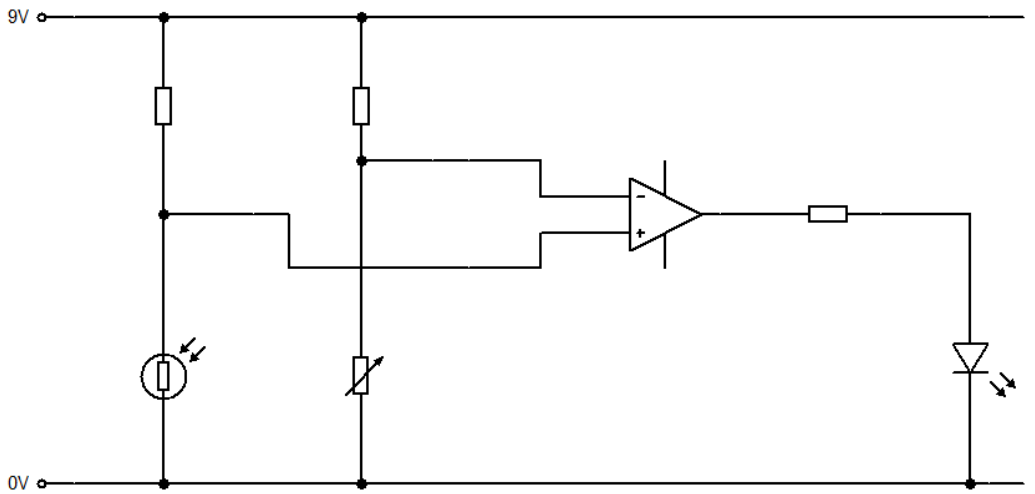
Question		Marking details	Marks available																
			AO1	AO2	AO3	Total	Maths												
5	a	B	1	0	0	1	0												
	b	The voltage V_1 increases	0	1	0	1	0												
	c	<table border="1" style="width: 100%; text-align: center;"> <thead> <tr> <th>Input 1 (V)</th> <th>Input 2 (V)</th> <th>Output V_2 (V)</th> <th>Is LED On or Off?</th> </tr> </thead> <tbody> <tr> <td>5.1</td> <td>7.3</td> <td>8.4V</td> <td>On</td> </tr> <tr> <td>7.5</td> <td>7.1</td> <td>0V</td> <td>Off</td> </tr> </tbody> </table> <p>1 mark for each correct column</p>	Input 1 (V)	Input 2 (V)	Output V_2 (V)	Is LED On or Off ?	5.1	7.3	8.4V	On	7.5	7.1	0V	Off	0	2	0	2	2
	Input 1 (V)	Input 2 (V)	Output V_2 (V)	Is LED On or Off ?															
5.1	7.3	8.4V	On																
7.5	7.1	0V	Off																
d	 <p>Two resistor elements in series – 1 Mark Variable resistor – 1 Mark Reference voltage connected to inverting input – 1 Mark Sensor Network connected to non-inverting input – 1 Mark {Note: Accept correctly connected potentiometer in place of first two points (2 Marks)}</p>	0	0	4	4	0													

Question			Marking details	Marks available				
				AO1	AO2	AO3	Total	Maths
5	e	(i)	$V_R = V_2 - V_{LED}$ $V_R = 8.4 - 2.2 = 6.2V$	0	1	0	1	1
		(ii)	12.5mA	1	0	0	1	0
		(iii)	$V = IR$ $R = \frac{V}{I}$ $R = \frac{6.2V}{12.5mA} \quad (1 - \text{Substitution}) \text{ ecf}$ $R = 496\Omega \quad (1 - \text{Answer})$	1	1	0	2	2
Question 5 total				3	5	4	12	5

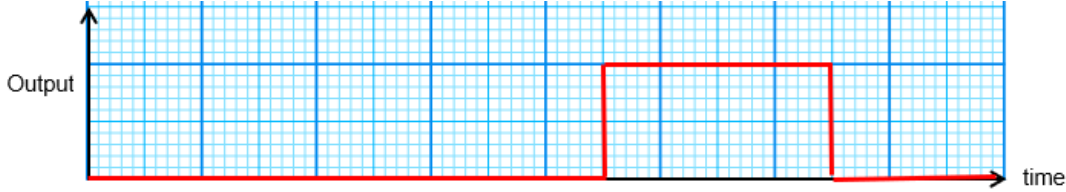
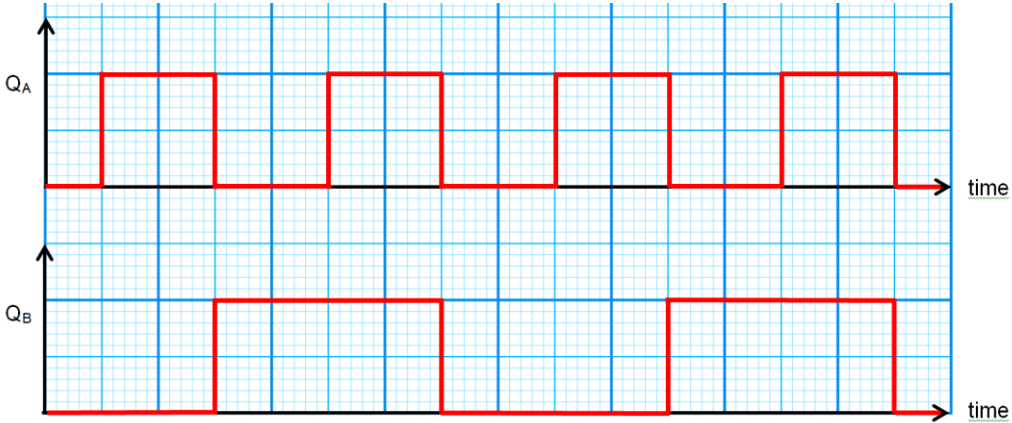
Question		Marking details	Marks available				
			AO1	AO2	AO3	Total	Maths
6	a	 <p>Q starting low – 1 mark Correct transitions – 1 mark</p>	1	1	0	2	0
	b	 <p>QA half frequency of Clock starting on first rising edge of clock – 1 mark QB half frequency of QA – 1 mark QB changes on falling edge of QA – 1 mark</p>	2	1	0	3	0
Question 6 total			3	2	0	5	0

Question		Marking details	Marks available				
			AO1	AO2	AO3	Total	Maths
7	a	$I_c = I_b h_{FE}$ (1 – formula) $I_b = \frac{I_c}{h_{FE}}$ (1 – formula manipulation) $I_b = \frac{200}{50}$ (1 - substitution) $I_b = 4mA$ (1 - answer)	1	3	0	4	4
	b	$V = IR$ $V = 4mA \times 1.2k$ (1 – Substitution) $V_{1.2k} = 4.8V$ (1 – Answer)	1	1	0	2	2
	c	$V_{IN} = V_{1.2k} + V_{BE}$ (1) $V_{IN} = 4.8 + 0.7 = 5.5V$ (1)	1	1	0	2	2
	d	$P = IV$ (1 - Formula) $P = 0.2 \times 6$ (1 - Substitution) $P = 1.2W$ (1 – Answer)	1	2	0	3	3

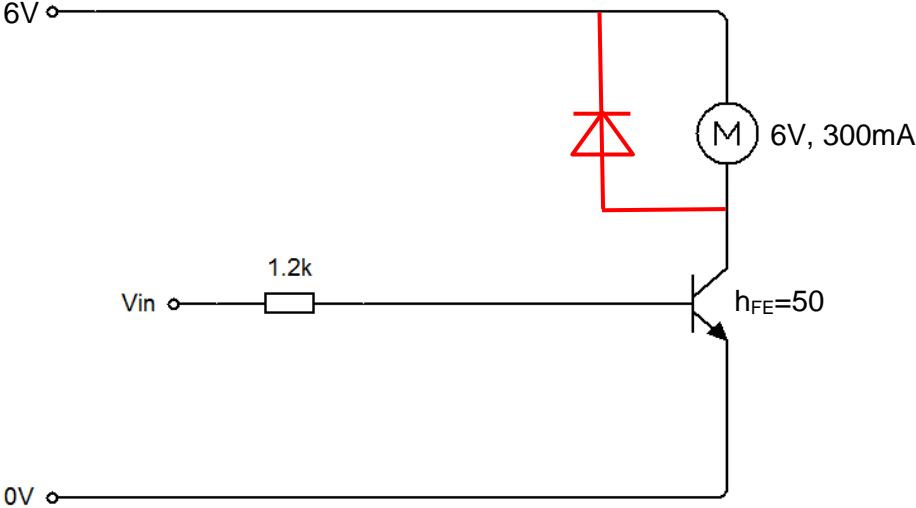
Question		Marking details	Marks available				
			AO1	AO2	AO3	Total	Maths
7	e	 <p>6V</p> <p>0V</p> <p>1.2k</p> <p>Vin</p> <p>M 6V, 300mA</p> <p>$h_{FE}=50$</p> <p>Diode in parallel with motor – 1 mark</p> <p>Inverse orientation - 1 mark</p>					
Question 7 total			2	0	0	2	0
			6	7	0	13	11

Question	Marking details	Marks available				
		AO1	AO2	AO3	Total	Maths
8	<p>Indicative Content:</p> <p>The circuit must provide a total current of 265mA, 250mA for the DVD player and 15mA for the Zener diode.</p> <p>The voltage across the 16Ω resistor must be $12 - 7.5 = 4.5\text{V}$.</p> <p>This allows a current of $4.5 / 16 = 281.25\text{mA}$ to flow which is sufficient.</p> <p>The power dissipated in the 16Ω resistor is $4.5^2 / 16 = 1.27\text{W}$ or $281.25\text{mA}^2 \times 16 = 1.27\text{W}$, therefore the power rating of the resistor is insufficient and should be increased to 1.5W as a minimum.</p> <p>The maximum current through the Zener diode is when the DVD player is disconnected – so 281.25mA, which gives a power dissipation of $7.5 \times 281.25\text{mA} = 2.109\text{W}$, so the chosen Zener diode is suitable.</p> <p>5-6 marks</p> <p>Recognition that the specification is only partially met with detailed analysis and description of all factors identified in the indicative content including correct elements and the modification required.</p> <p><i>There is a sustained line of reasoning which is coherent, substantiated and logically structured. The information included in the response is relevant to the argument.</i></p> <p>3-4 marks</p> <p>Recognition that the specification is only partially met with some analysis and description of at least two factors identified in the indicative content including correct elements and the modification required.</p> <p><i>There is a line of reasoning which is partially coherent, supported by some evidence and with some structure. Mainly relevant information is included in the response but there may be some minor errors or the inclusion of some information not relevant to the argument.</i></p>					

Question	Marking details	Marks available				
		AO1	AO2	AO3	Total	Maths
8	<p>1-2 marks Recognition that the specification is only partially met with minimal analysis and description of just one factor identified in the indicative content including correct elements. <i>There is a basic line of reasoning which is not coherent, supported by limited evidence and with very little structure. There may be significant errors or the inclusion of information not relevant to the argument.</i></p> <p>0 marks No recognition that the specification is only partially met with no analysis or description of any factors identified in the indicative content. <i>Response not creditworthy or not attempted.</i></p>	0	3	3	6	3
Question 8 total		0	3	3	6	3
PAPER TOTAL						
		35	35	10	80	31