



GCSE

3300U10-1

TUESDAY, 24 MAY 2022 – MORNING

MATHEMATICS

UNIT 1: NON – CALCULATOR

FOUNDATION TIER

1 hour 25 minutes plus your additional time allowance

THE USE OF A CALCULATOR IS NOT PERMITTED IN THIS EXAMINATION

Surname: _____

First name(s): _____

Centre Number: _____

Candidate Number: **0** _____

For Examiner's use only

Question	Maximum Mark	Mark Awarded
1.	5	
2.	2	
3.	1	
4.	2	
5.	2	
6.	3	
7.	4	
8.	3	
9.	2	
10.	5	
11.	3	
12.	4	
13.	3	
14.	4	
15.	4	
16.	3	
17.	3	
18.	4	
19.	3	
Total	60	

(Turn over)

ADDITIONAL MATERIALS

A ruler, a protractor and a pair of compasses may be required.

ITEMS INCLUDED WITH QUESTION PAPER

A separate Formula List.

A separate Diagram Booklet.

Cut out shapes for Question 3 and Question 9.

The Diagram Booklet MUST be handed in to the invigilators and sent for marking.

INSTRUCTIONS TO CANDIDATES

Use black ink, black ball – point pen, black felt tip or your usual method.

Write your name, centre number and candidate number in the spaces on the front cover.

Answer ALL questions.

Write your answers in the spaces provided.

If you run out of space, use the additional page(s) at the back of the booklet.

Question numbers must be given for the work written on the additional page(s).

Take π as 3.14

INFORMATION FOR CANDIDATES

You should give details of your method of solution when appropriate.

Unless stated, diagrams are not drawn to scale.

Scale drawing solutions will not be acceptable where you are asked to calculate.

The number of marks is given in brackets at the end of each question or part – question.

In question 6, the assessment will take into account the quality of your linguistic and mathematical accuracy in writing.

In question 10, the assessment will take into account the quality of your organisation and communication.

1. (a) Write **2376** correct to the nearest ten.

[1 mark]

(b) Add **643** and **8972**

[1 mark]

continued on the next page . . .

(Turn over)

Question 1 continued

1. (c) Calculate one fifth of 335

[1 mark]

(d) Subtract 516 from 894

[1 mark]

continued on the next page . . .

(Turn over)

Question 1 continued

1. (e) Using all of the following digits,
write down the smallest possible
4 – digit number.

7 1 5 2

[1 mark]

(Turn over)

2. (a) Tim chooses one letter at random from the word **TOMATO**.

Describe the chance that Tim chooses the letter **T**.

Circle the correct expression from those given below.

impossible
unlikely
an even chance
likely
certain

[1 mark]

continued on the next page . . .

(Turn over)

Question 2 continued

2. (b) Megan chooses one letter at random from the word **BANANA**.

Describe the chance that Megan chooses the letter **A**.

Circle the correct expression from those given below.

impossible
unlikely
an even chance
likely
certain

[1 mark]

(Turn over)

3. Look at the diagram for Question 3 in the separate Diagram Booklet.

Shade the smallest number of squares to make MN a line of symmetry.

A set of cut out shapes are available for this question.

[1 mark]

4. (a) Look at the diagram for Question 4 (a) in the separate Diagram Booklet.

Measure and write down the size of angle X .

$X =$ _____ °

[1 mark]

- (b) Look at the diagram for Question 4 (b) in the separate Diagram Booklet.

The diagram is NOT drawn to scale.

In the space below the diagram, draw angle $ABC = 145^\circ$ accurately.

The line BC has been drawn for you.

[1 mark]

5. (a) How much time has passed between 8:30 a.m. and 2:15 p.m. on the same day?

[1 mark]

- (b) Look at the diagram for Question 5 (b) in the separate Diagram Booklet.

Shade $\frac{2}{3}$ of the shape.

[1 mark]

(Turn over)

6. IN THIS QUESTION, YOU WILL BE ASSESSED ON THE QUALITY OF YOUR ACCURACY IN WRITING.

Look at the diagram for Question 6 in the separate Diagram Booklet.

The diagram is NOT drawn to scale.

Two identical small circles fit in a larger circle, as shown.

AB is a straight line passing through the centres of all three circles.

The radius of each of the small circles is **7.5 cm**.

Calculate the length of the diameter of the large circle.

You must show all your working.

[2 marks + 1 mark W]

7. (a) Simplify $12m - 19m + 10m$

[1 mark]

continued on the next page . . .

(Turn over)

Question 7 continued

7. (b) Solve the following equations.

(i) $3y = 189$

[1 mark]

(ii) $27 - x = 15$

[1 mark]

continued on the next page . . .

(Turn over)

Question 7 continued

7. (c) Write down the value of $\sqrt{36}$

[1 mark]

(Turn over)

9. Look at the diagram for Question 9 in the separate Diagram Booklet.

Complete the diagram so that the grid has rotational symmetry of order 4 about the centre, ●

You must shade as few squares as possible.

A cut out shape is available for this question.

[2 marks]

10. IN THIS QUESTION, YOU WILL BE ASSESSED ON THE QUALITY OF YOUR ORGANISATION AND COMMUNICATION.

A bucket can hold 4000 ml of water.

A jug can hold 2.5 litres of water.

An empty tank has a capacity of 17 litres.

The tank is filled to the top using a combination of full buckets and full jugs of water.

How many full buckets and full jugs must be used to fill the tank exactly?

You must show all your working.

Number of full buckets _____

Number of full jugs _____

[4 marks + 1 mark OC]

11. Raji chooses one number at random from this list of numbers.

2, 4, 6, 8, 10, 12, 14, 16, 18, 20

On the probability scale provided for Question 11 in the separate Diagram Booklet, mark the points **A**, **B** and **C** where:

- **A** is the probability of Raji choosing an even number
- **B** is the probability of Raji choosing a number greater than 8
- **C** is the probability of Raji choosing a square number.

[3 marks]

(Turn over)

12. Calculate each of the following.

(a) $3^2 \times 2^3$

[2 marks]

(b) $-124 \div 4$

[1 mark]

continued on the next page . . .

(Turn over)

Question 12 continued

12. (c) 15% of 280

[1 mark]

13. Write 0.3 , $\frac{8}{25}$ and 31% in ascending order.

You must show all your working.

Smallest value

Greatest value

[3 marks]

14. Look at the diagram for Question 14 in the separate Diagram Booklet.

The diagram is NOT drawn to scale.

The diagram shows triangle ABC and triangle CBD .

In the diagram:

$$CB = CD$$

Angle ACB is a right angle.

An angle of 220° is shown on the diagram.

Angle $CDB = x$.

Calculate the size of angle x .

You must show all your working.

$x = \underline{\hspace{10em}}^{\circ}$

[4 marks]

15. (a) Find a whole number value of n ,
so that $7n - 9$ is a multiple of 4
You must show all your working.

When $n =$ _____, $7n - 9$ is a multiple of 4

[2 marks]

continued on the next page . . .

(Turn over)

Question 15 continued

15. (b) Find a whole number value of n ,
so that $3n - 5$ is a prime number.
You must show all your working.

When $n =$ _____, $3n - 5$ is a prime number.

[2 marks]

(Turn over)

16. (a) A bag contains red balls, green balls and yellow balls.

The number of green balls is equal to the number of yellow balls.

Mali picks one ball from the bag at random.

The probability that she will pick a red ball is **0.3**

Find the probability that Mali will pick a yellow ball.

[2 marks]

continued on the next page . . .

(Turn over)

Question 16 continued

16. (b) A different bag contains **10** balls.
Some of the balls in the bag are blue.
All the other balls are white.
Morgan picks a ball from the bag at random.
He says,

The probability that I will pick a blue ball from the bag is 0.25

Explain why Morgan cannot be correct.

18. Look at the diagrams for Question 18 in the separate Diagram Booklet. The diagrams are NOT drawn to scale.

The diagrams show a rectangle and a trapezium.

The area of the rectangle = 48 m^2

The width of the rectangle is represented by X . The height of the trapezium is twice the width of the rectangle.

Calculate the area of the trapezium. You must show all your working.

[4 marks]

(Turn over)

[3 marks]

END OF PAPER

TOTAL 60 MARKS

(Turn over)



GCSE

3300U10-1

TUESDAY, 24 MAY 2022 – MORNING

MATHEMATICS

UNIT 1: NON – CALCULATOR

FOUNDATION TIER

**The Diagram Booklet MUST be handed in
to the invigilators and sent for marking.**

Diagram Booklet

Surname: _____

First name(s): _____

Centre Number: _____

Candidate Number: 0 _____

Question 3

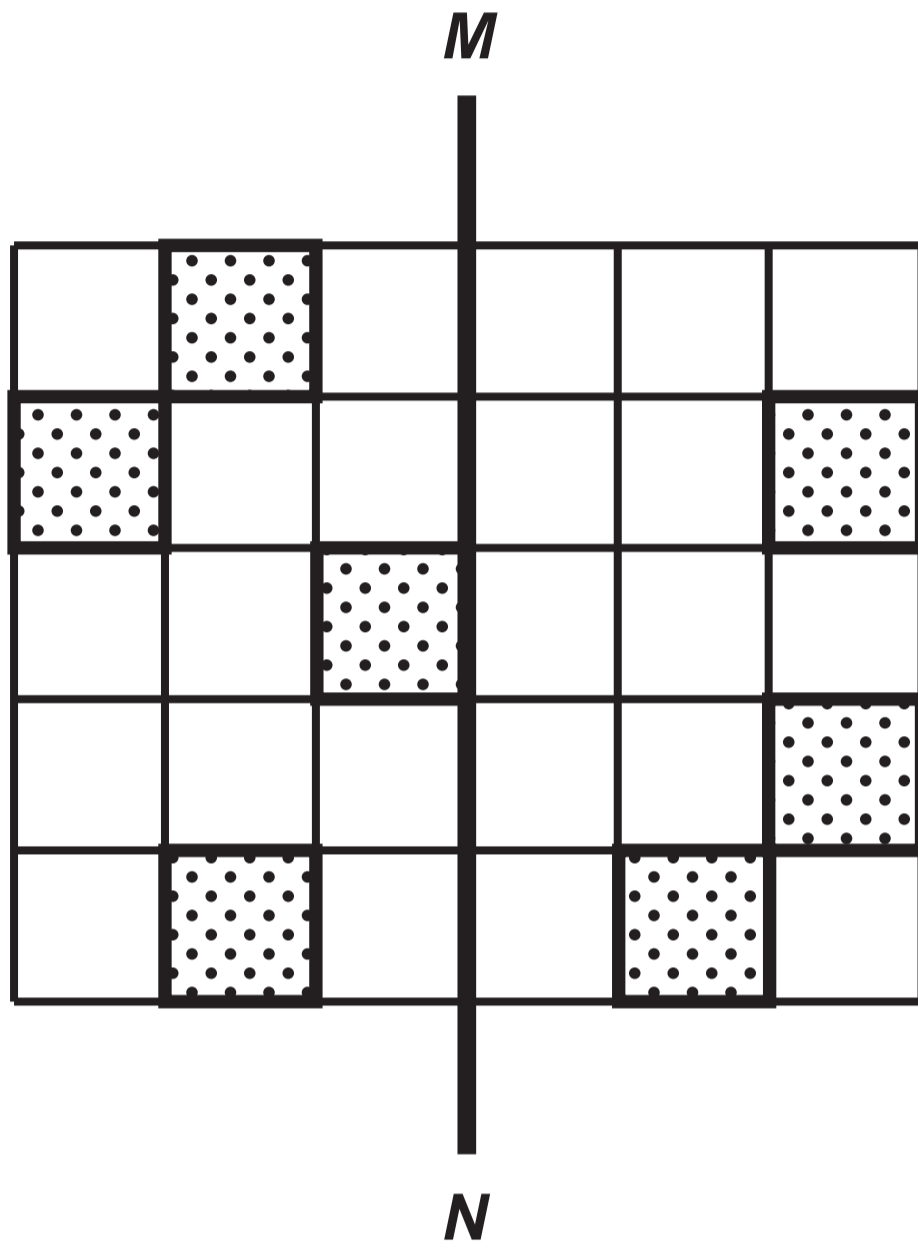

Question 4 (a)

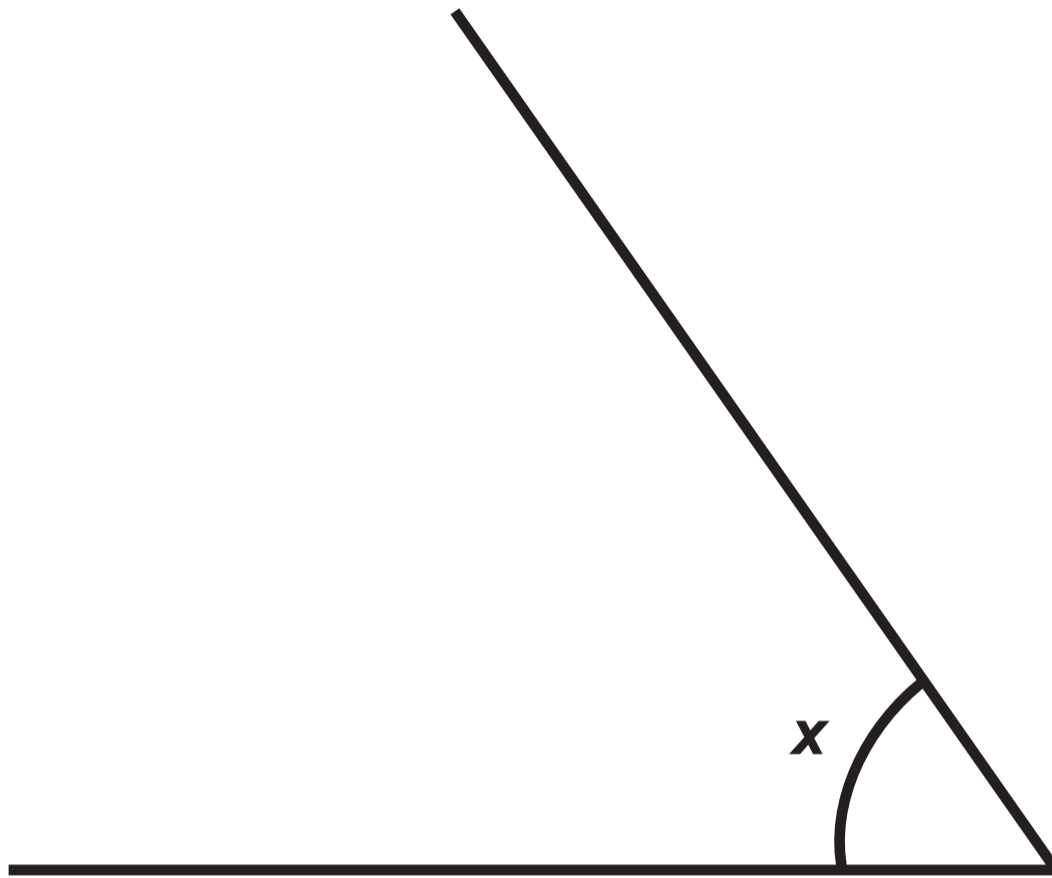

Question 4 (b)

Diagram NOT drawn to scale

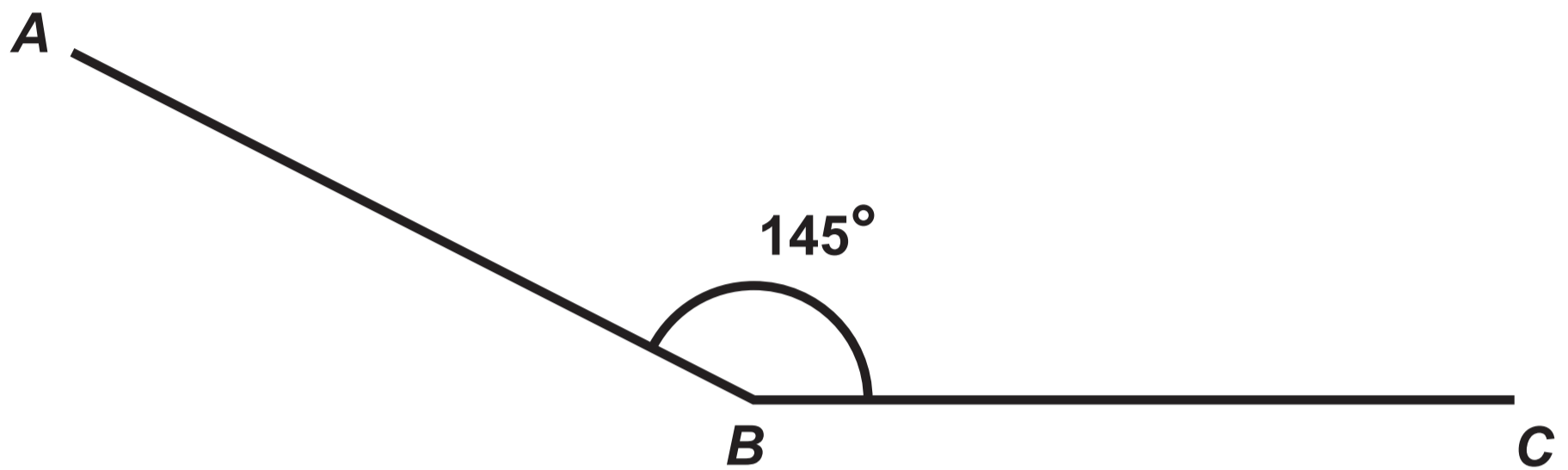

In the space below, draw angle $ABC = 145^\circ$ accurately.



Question 5 (b)

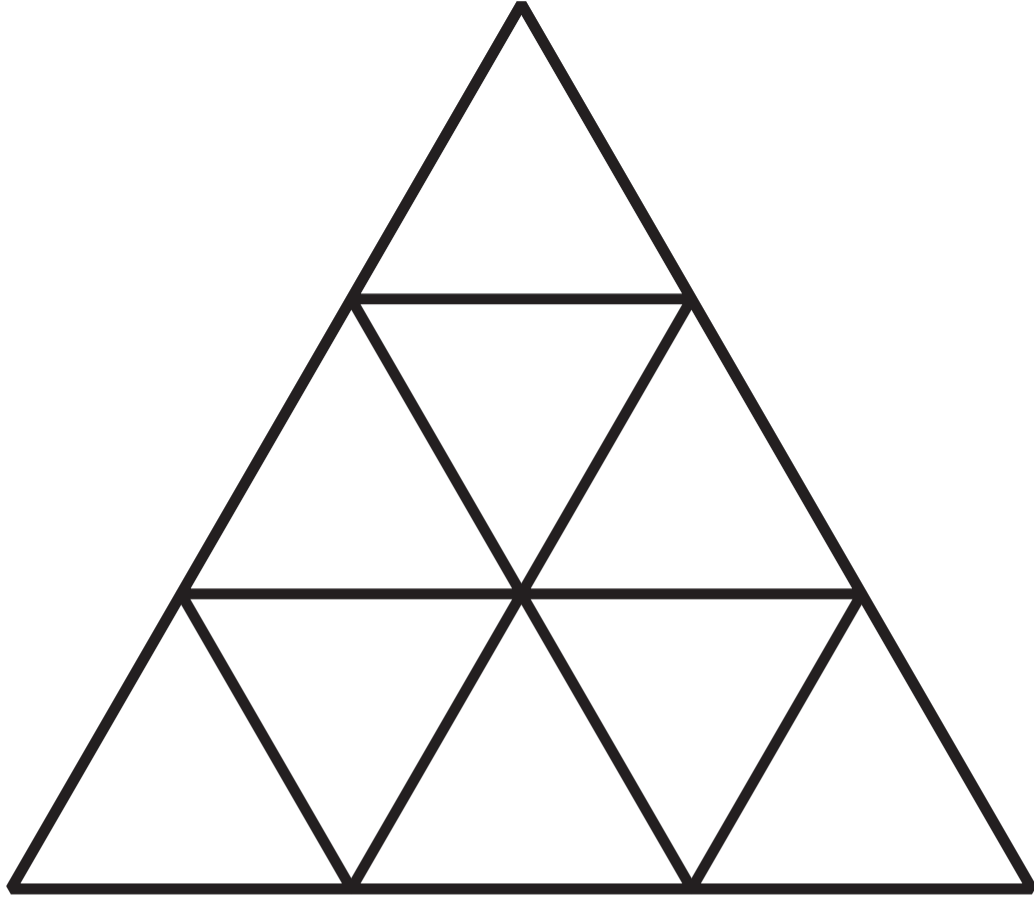

Question 6

Diagram NOT drawn to scale

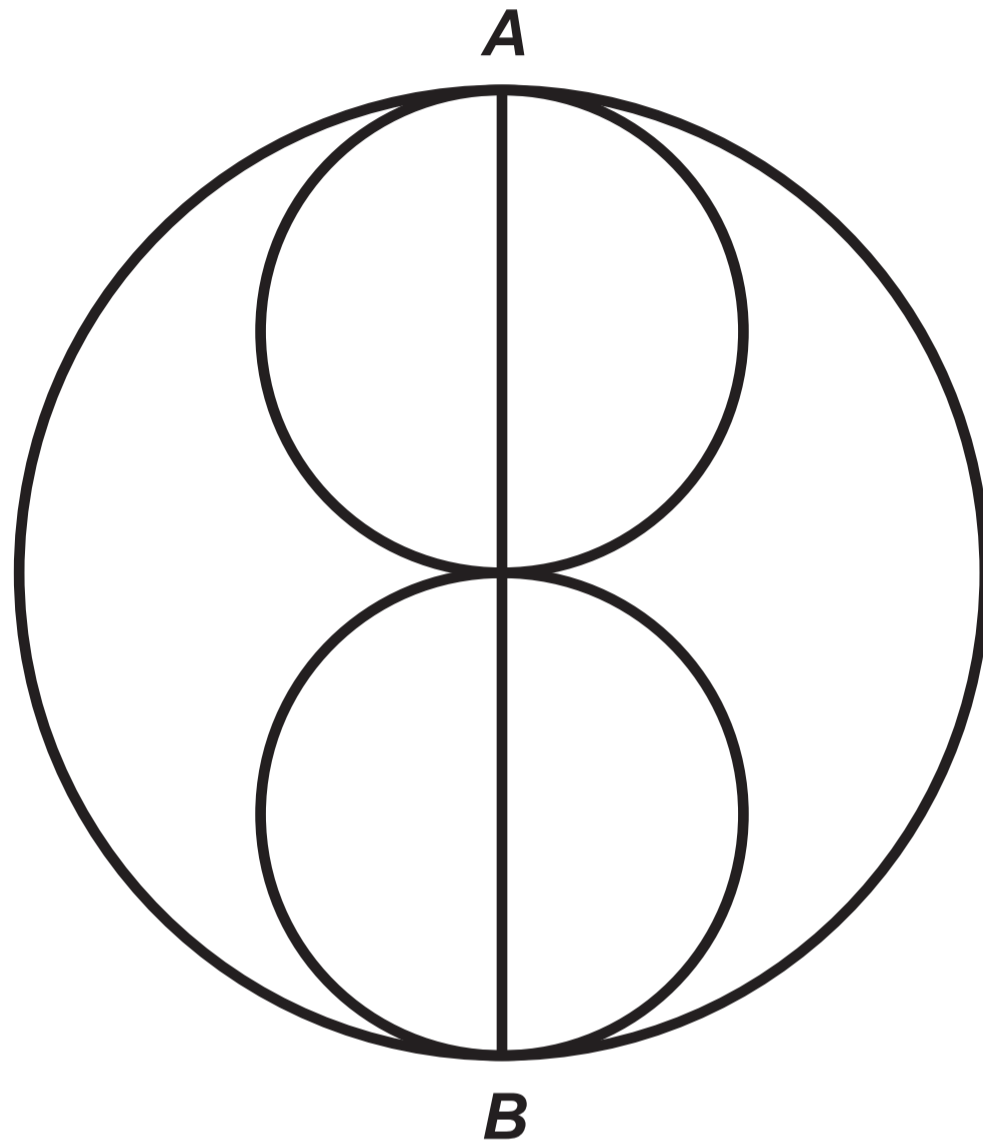

Question 9

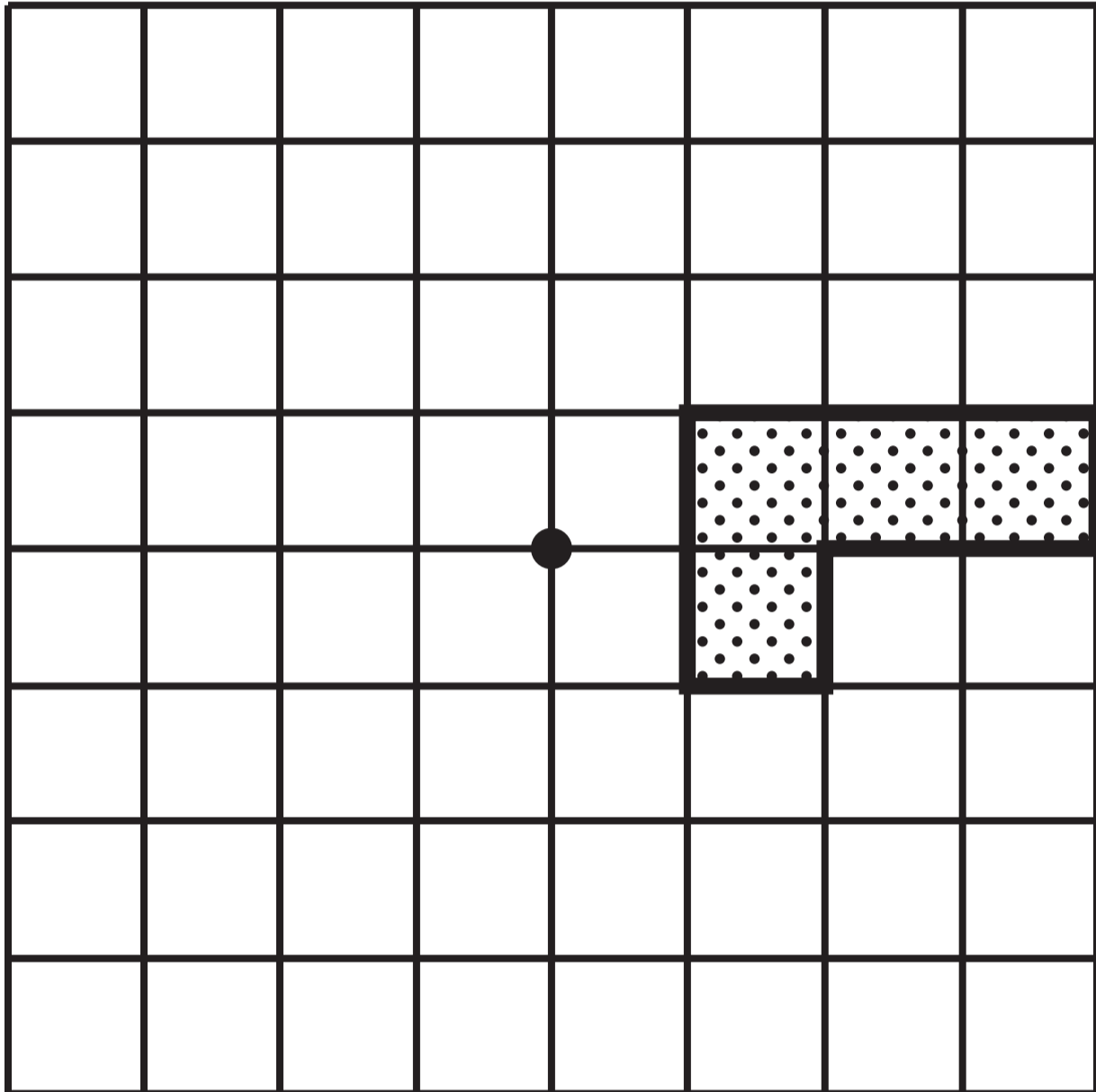

Question 11

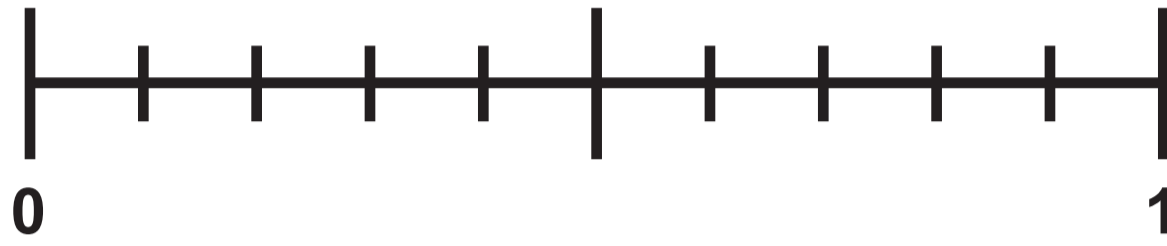

Question 14

Diagram NOT drawn to scale

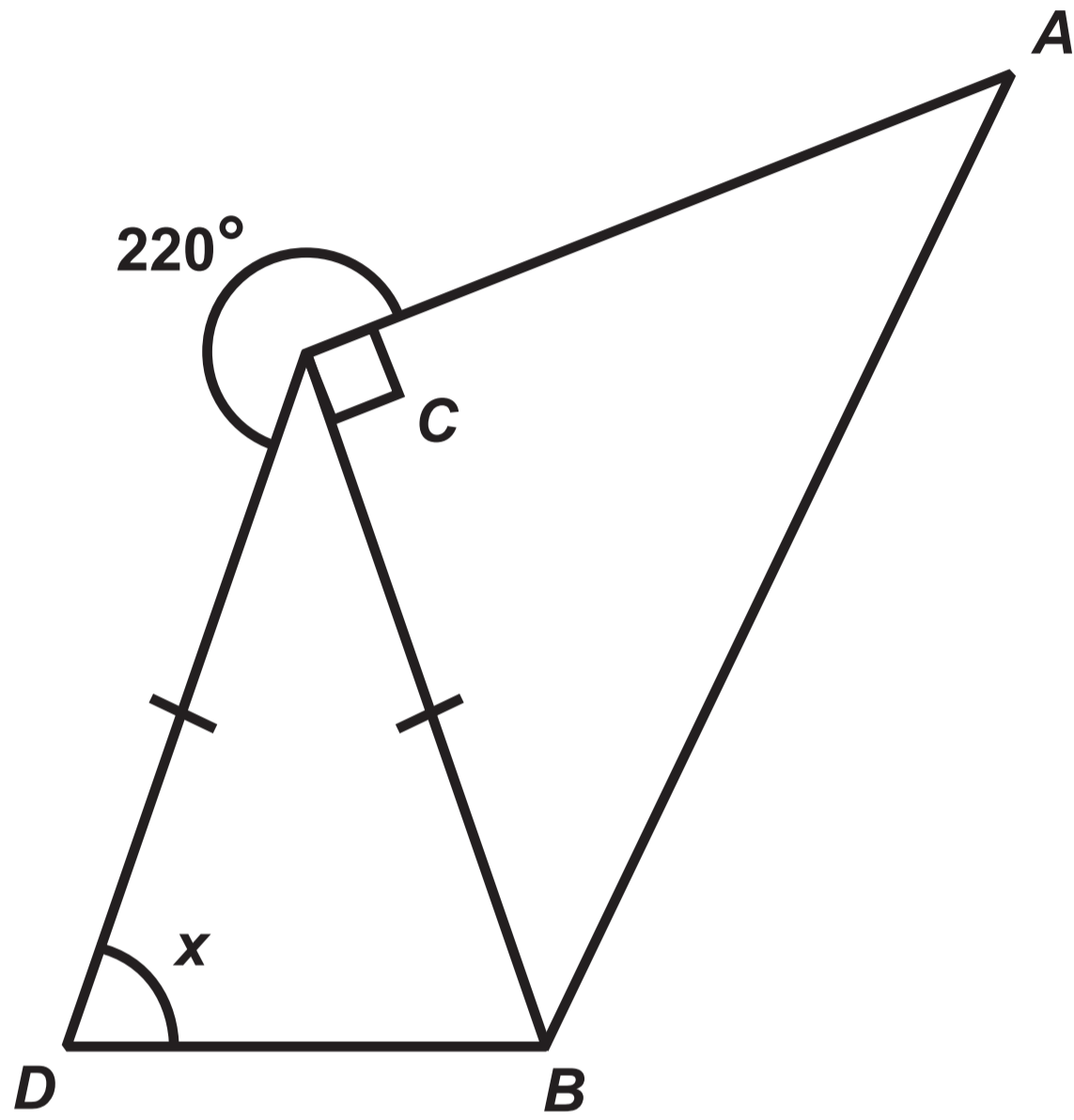

Question 18

Diagrams NOT drawn to scale

Rectangle

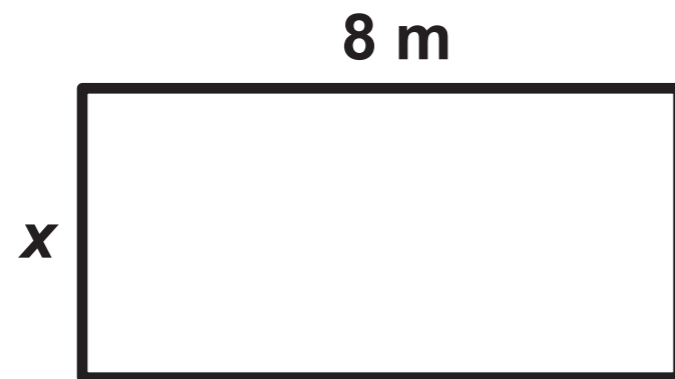

Trapezium

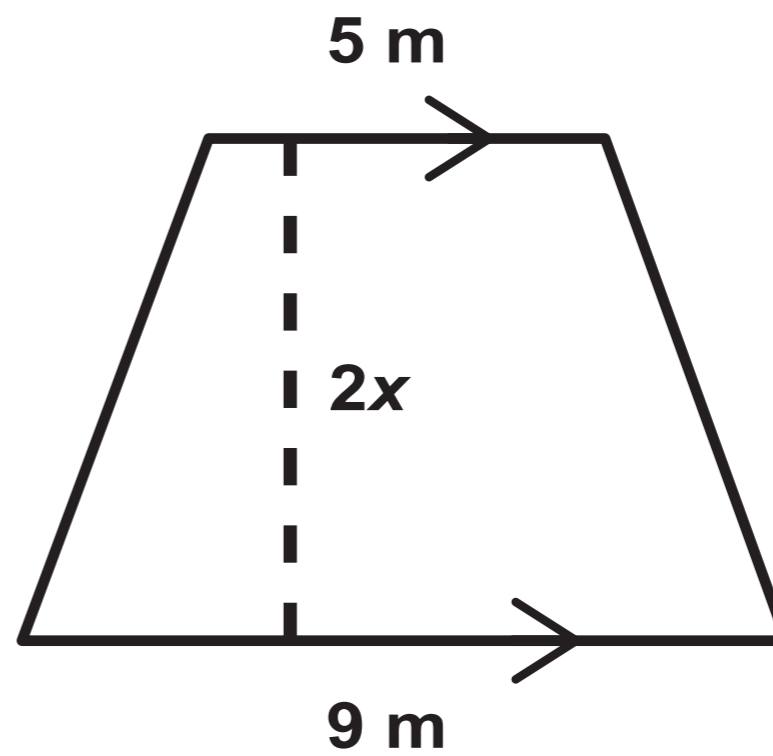

**GCSE
MATHEMATICS
and
NUMERACY**



**FORMULA LIST
FOUNDATION TIER
GCSE**

You must not write on these formula pages.

Anything you write on these formula pages will gain NO credit.

Formula List – Foundation Tier

Area of trapezium $= \frac{1}{2} (a + b) h$

