



GCSE

3410UB0-1

**FRIDAY, 27 MAY 2022 – MORNING**

**CHEMISTRY – Unit 2:**

**Chemical Bonding, Application of Chemical Reactions  
and Organic Chemistry**

**HIGHER TIER**

**1 hour 45 minutes plus your additional time allowance**

**Surname** \_\_\_\_\_

**First name(s)** \_\_\_\_\_

**Centre Number** \_\_\_\_\_

**Candidate Number** 0 \_\_\_\_\_



## **ADDITIONAL MATERIALS**

**In addition to this paper you may require a calculator and a ruler.**

## **ITEMS INCLUDED WITH QUESTION PAPER**

**A separate Data Booklet.**

**A separate Diagram Booklet.**

**The Diagram Booklet MUST be handed in to the invigilators and sent for marking.**

## **INSTRUCTIONS TO CANDIDATES**

**Use black ink, black ball-point pen or your usual method.**

**Write your name, centre number and candidate number in the spaces provided on the front cover.**

**Answer ALL questions.**

**Write your answers in the spaces provided in this booklet. If you run out of space, use the additional pages at the back of the booklet, taking care to number the question(s) correctly.**



**INFORMATION FOR CANDIDATES**

**The number of marks is given in brackets at the end of each question or part-question.**

**Question 11 is a quality of extended response (QER) question where your writing skills will be assessed.**

**The Periodic Table and the formulae for some common ions are printed in the separate Data Booklet.**

<b>For Examiner's use only</b>		
<b>Question</b>	<b>Maximum Mark</b>	<b>Mark Awarded</b>
<b>1.</b>	<b>6</b>	
<b>2.</b>	<b>7</b>	
<b>3.</b>	<b>7</b>	
<b>4.</b>	<b>5</b>	
<b>5.</b>	<b>9</b>	
<b>6.</b>	<b>10</b>	
<b>7.</b>	<b>5</b>	
<b>8.</b>	<b>9</b>	
<b>9.</b>	<b>7</b>	
<b>10.</b>	<b>9</b>	
<b>11.</b>	<b>6</b>	
<b>Total</b>	<b>80</b>	

Answer ALL questions.

- 1 (a) The table below shows the electronic structure of the elements present in potassium fluoride.

Element	Electronic structure
potassium	2,8,8,1
fluorine	2,7

**DIAGRAM 1** shows the electron transfer that occurs when potassium reacts with fluorine to form potassium fluoride. The • and × symbols are outer shell electrons.

A student was asked to draw a diagram showing the electronic structures and charges on the ions formed. This is shown in **DIAGRAM 2**. There are **TWO** mistakes in the student's answer.

- (i) Circle the **TWO** mistakes in the student's answer. [2 marks]
- (ii) Name the type of bonding found in potassium fluoride. [1 mark]
-

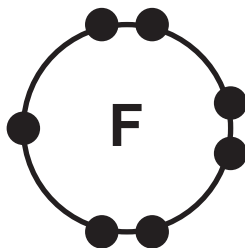


1 (a)(iii)

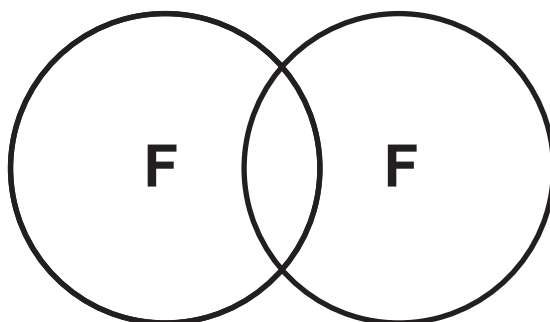
**DIAGRAM 3** shows four different structures. Give the **LETTER** of the structure most likely to represent potassium fluoride. [1 mark]

Letter \_\_\_\_\_

(b) The diagram below shows the electrons in the outer shell of an atom of fluorine.



Complete the diagram to show the outer shell electrons in a molecule of fluorine. [2 marks]



6

(Turn over)



**2 (a) DIAGRAM 4 outlines the manufacture of ammonia by the Haber process.**

**(i) Name the raw material X. [1 mark]**

---

**(ii) The pressure used in the Haber process is 200 atm. State why a higher pressure is NOT used. [1 mark]**

---

---

**(iii) At 450 °C, the reaction is very slow. Iron is used in the process to speed up the reaction. Give the name for a substance used to speed up a chemical reaction. [1 mark]**

---

**(iv) The reaction between nitrogen and hydrogen is represented by the equation in DIAGRAM 5.**

**Complete the equation in DIAGRAM 6 using the key. [2 marks]**

**(Turn over)**



**THIS IS A BLANK PAGE**

**TURN OVER**

Fertiliser	Test for positive ion	Test for negative ion
<b>A</b>	On adding sodium hydroxide solution and warming, a pungent smelling gas is formed which turns red litmus blue	On adding barium chloride solution a white precipitate forms
<b>B</b>	Lilac flame test	On adding silver nitrate solution a white precipitate forms
<b>C</b>	On adding sodium hydroxide solution and warming, a pungent smelling gas is formed which turns red litmus blue	On adding silver nitrate solution a white precipitate forms

- 2 (b) One of the main uses of ammonia is in the manufacture of fertilisers.

The table opposite shows the results obtained when tests were carried out on three different fertilisers A, B and C.

Give the LETTER of the fertiliser which is ammonium sulfate. [1 mark]

Letter \_\_\_\_\_

- (c) Ammonia reacts with chlorine to form nitrogen and hydrogen chloride.

Complete the balancing of the equation for this reaction. [1 mark]



7



**3 (a) The list below shows part of the reactivity series.**

**sodium**

**aluminium**

**(carbon)**

**tin**

**copper**

**silver**

**(i) Tin is extracted from its ore by heating with carbon. Aluminium is extracted from its ore using a different method. Give the name of the method used to extract aluminium. [1 mark]**

---



**THIS IS A BLANK PAGE**

**TURN OVER**



3 (a)(ii)

The equation below shows the extraction of tin from tin oxide using carbon.



Tick (✓) the box next to the correct statement. [1 mark]

Carbon is reduced

Tin is oxidised

Tin oxide is reduced

Carbon dioxide is oxidised

(iii) When aluminium and copper(II) oxide are heated together, aluminium oxide and copper are formed.

Complete and balance the equation opposite for this reaction. [3 marks]

(Turn over)



3 (b) A teacher wanted to find out the position of four metals A, B, C and D in the reactivity series.

She heated each metal in turn with oxides of the other three. The results were as follows.

A reduced the oxide of C

B reduced the oxide of A

B reduced the oxide of C

D reduced the oxide of B

Place the metals in order of reactivity.  
[2 marks]

Most reactive \_\_\_\_\_  
\_\_\_\_\_  
\_\_\_\_\_

Least reactive \_\_\_\_\_

7



4 The equation in DIAGRAM 7 shows the bonds which are broken and the bonds which are formed during the electrolysis of water.

(a) The total energy needed to break the bonds in the reactant is 1 856 kJ.

Calculate the energy needed to break ONE O—H bond. [2 marks]

Energy = \_\_\_\_\_ kJ

(b) The total energy released when the bonds in the products are formed is 1 370 kJ.

The bond energy for H—H is 436 kJ.

Calculate the energy released when making ONE O=O bond. [2 marks]

Energy = \_\_\_\_\_ kJ

(Turn over)



- 4 (c) The energy profile diagram in DIAGRAM 8 shows the reaction to be endothermic.  
[1 mark]

On the diagram use the symbol ( $\updownarrow$ ) to show the overall energy change for the reaction.

5



- 5 The chart in **DIAGRAM 9** describes the laboratory preparation of ethanol from glucose solution.

The equation for the reaction occurring in process **A** is shown below.



- (a)(i) Give the name of the processes **A**, **B** and **C**.  
[3 marks]

**A** \_\_\_\_\_

**B** \_\_\_\_\_

**C** \_\_\_\_\_



5 (a)(ii)

A teacher wanted to show that ethanol is collected in process C.

I. Tick (✓) the box next to the chemical test that the teacher would carry out to positively identify the liquid as ethanol. [1 mark]

add bromine water

add acidified potassium dichromate solution

add silver nitrate solution

add barium chloride solution

II. Tick (✓) the box next to the observation you would expect. [1 mark]

orange to colourless

orange to green

green to orange

colourless to green

(Turn over)



5 (b) Alcohols can also be identified using infrared spectroscopy.

Bond	Wavenumber (cm <sup>-1</sup> )
C=C	1 620 to 1 670
C=O	1 650 to 1 750
C—H	2 800 to 3 100
O—H	2 500 to 3 550

(i) The structural formula and the infrared spectrum of ethanol are shown in DIAGRAMS 10A and 10B.

Give the LETTER of the peak that can be used to identify an alcohol. [1 mark]

Letter \_\_\_\_\_

(ii) The structural formula and the infrared spectrum of ethanoic acid are shown in DIAGRAMS 11A and 11B.

Give the LETTER of the peak that can be used to distinguish ethanoic acid from ethanol. [1 mark]

Letter \_\_\_\_\_



**5 (c) Ethanol is found in alcoholic drinks.**

**(i) Give ONE health problem associated with alcohol abuse over a LONG period of time. [1 mark]**

---

---

**(ii) Give ONE social problem associated with the excessive intake of alcohol (binge drinking) during an evening. [1 mark]**

---

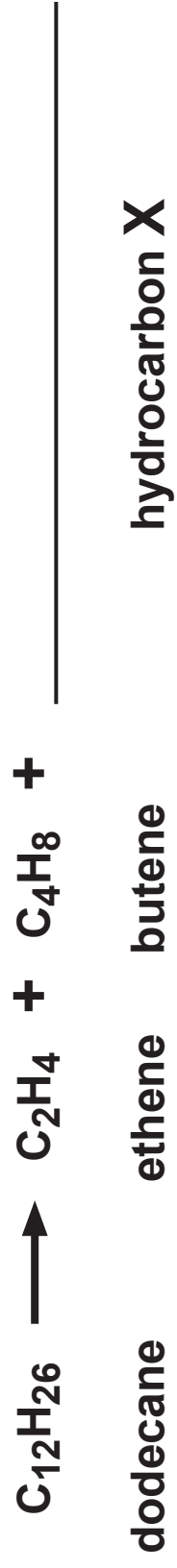
---

<b>9</b>



**THIS IS A BLANK PAGE**

**TURN OVER**



- 6 (a) Kerosene is one of the fractions separated during the fractional distillation of crude oil.

Kerosene contains dodecane,  $C_{12}H_{26}$ .

Dodecane undergoes a further process **A** to form smaller, more useful hydrocarbons, ethene, butene and one molecule of hydrocarbon **X**.

- (i) Name process **A**. [1 mark]
- 
- 

- (ii) Complete the equation opposite for this reaction. [1 mark]

- (b)  $C_4H_8$  has three isomers. **DIAGRAM 12** shows two of the three isomers.

The third isomer is methylpropene. Draw its structure in the box in the diagram booklet. [1 mark]



**6 (c)(i) Polyethene is made from ethene by addition polymerisation. Draw the structure of the repeating unit for polyethene in DIAGRAM 13. [1 mark]**

**(ii) The presence of the double bond in ethene can be confirmed using bromine water.**

**I. Complete the equation for the reaction between ethene and bromine in DIAGRAM 14. [1 mark]**

**II. Tick (✓) the box next to the name of the product formed. [1 mark]**

**1,2-dibromoethene**

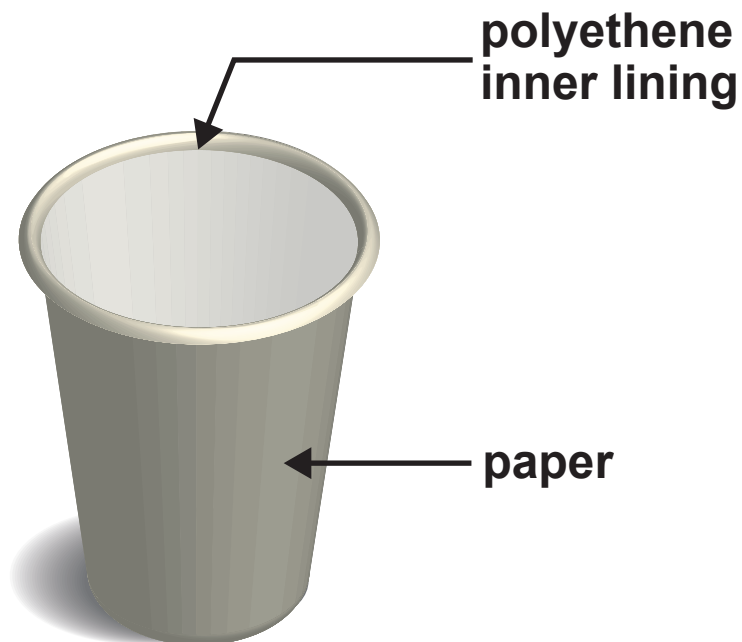
**1,1-dibromoethane**

**1,2-dibromoethane**

**1,1-dibromoethene**



- 6 (d) In the UK, around 3 billion disposable coffee cups are used every year. Each paper coffee cup is lined with polyethene which is impossible to remove at a recycling plant. If the automated machine that sorts waste at a recycling centre detects a plastic lining, it rejects the cup sending it to general household waste.





**6 (d)(i) Most general household waste is disposed of in landfill sites.**

**Apart from using landfill sites, give the OTHER disposal method of general household waste. State an environmental problem associated with the method. [2 marks]**

**Method**

---

---

**Problem**

---

---

---

---



6 (d)(ii)

Recycling helps to conserve raw materials.  
Name the raw material used to make  
polyethene. Give the main reason why it  
is important to conserve this raw material.  
[2 marks]

Raw material

---

---

Main reason

---

---

---

---

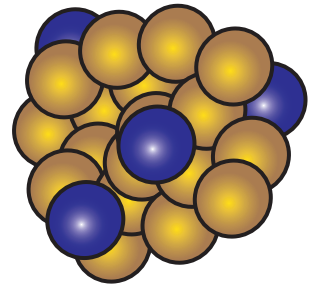
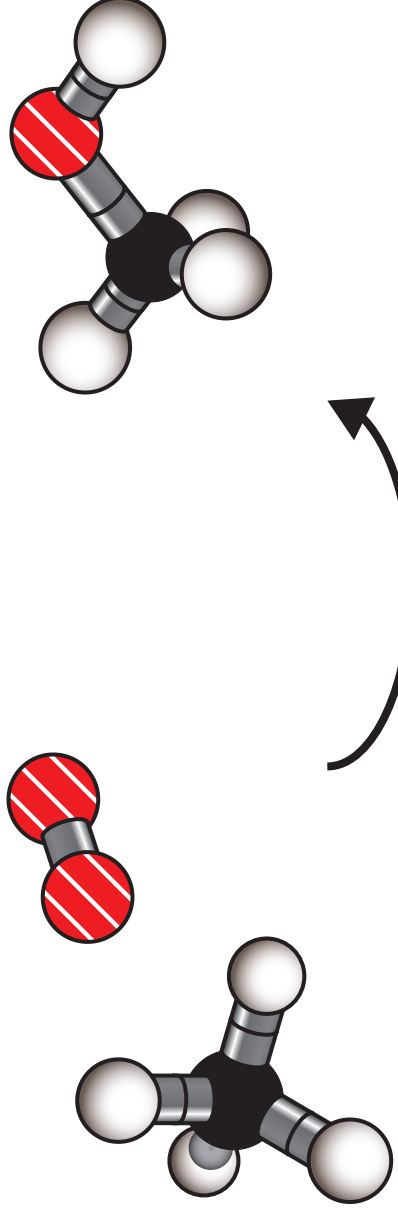
10

(Turn over)



**THIS IS A BLANK PAGE**

**TURN OVER**



gold palladium nano-particle catalyst

## 7 Scientists make 'new fuel' discovery

Methanol is vital in manufacturing a wide range of fuels and chemicals. Methanol is produced from methane found in natural gas. At the moment methane is condensed into liquid natural gas at the site where it is extracted and transported in pressurised containers.

Traditionally, methanol is created by converting methane into hydrogen and carbon monoxide molecules at high temperature, then rearranging the atoms in a different order in a second highly pressurised process. The current two-stage process is very energy intensive, as it burns a lot of fossil fuel to achieve high temperatures.



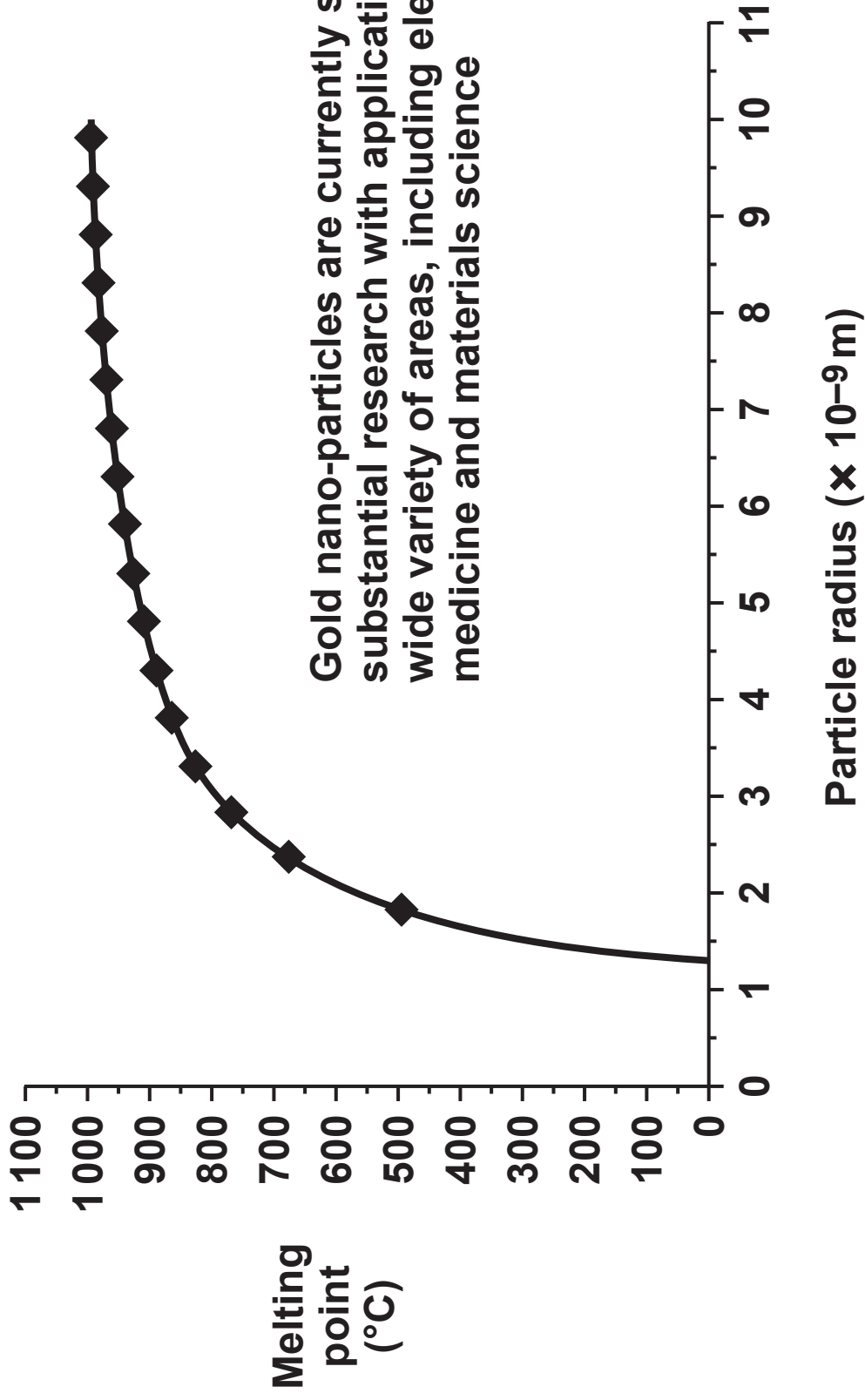
Scientists have discovered a new way of creating greener and cheaper methanol from methane using gold palladium nano-particles to initiate a one-stage chemical reaction that can be done at temperatures no higher than 50 °C. In this new process the gold palladium nano-particles act as a catalyst enabling methane and oxygen to combine, forming methanol in a single stage reaction.

(Turn over)



**THIS IS A BLANK PAGE**

**TURN OVER**



Gold nano-particles are currently subject to substantial research with applications in a wide variety of areas, including electronics, medicine and materials science

**7 (continued)**

The discovery opens up the prospect of easily converting methane into methanol at the site where the methane is extracted, so that methanol can be transported as a liquid at atmospheric pressure.

Nano-particles have very different and unique properties from their bulk form.

**Bulk gold**

- shiny
- always gold colour
- inert
- conducts electricity
- melting point 1 064 °C

**Gold nano-particles**

- found in a range of colours (100 nm purple; 20 nm red; 1 nm yellow)
- never gold colour
- very good catalysts
- semi-conductors
- range of melting points



**THIS IS A BLANK PAGE**

**TURN OVER**



7 (a) Tick (✓) the box next to the TWO statements which support the opinion that the new method is more ENVIRONMENTALLY FRIENDLY. [2 marks]

It is cheaper than the traditional method

It uses less energy

It reduces carbon dioxide emissions

It uses gold nano-particles

It uses more fuel

(b) Complete the balanced equation on the opposite page for the NEW method of converting methane to methanol. [2 marks]

(Turn over)



7 (c) Tick (✓) the box next to the TRUE statement.  
[1 mark]

The melting points of gold nano-particles and bulk gold are the same

Gold nano-particles have a fixed melting point value

Smaller gold nano-particles have higher melting points than larger gold nano-particles

The melting point of gold nano-particles depends on their size

5



- 8 Mountaineers often choose an ethanol burner when hiking in extremely cold conditions.



ethanol burner

A group of students was asked to investigate how the mass of ethanol burned is related to the amount of energy given out.

Four students each burned a different mass of ethanol and recorded the temperature rise of 250 g of water. DIAGRAM 15 shows the apparatus used by each of the students. They used their results to calculate the energy given out.

The table shows the students' results.

Student	Mass of ethanol burned (g)	Energy given out ( $J \times 10^4$ )
A	1.1	2.2
B	1.8	3.6
C	2.9	5.8
D	4.2	8.4

(Turn over)



**THIS IS A BLANK PAGE**

**TURN OVER**

**energy given out (J) = 4.2 x temperature rise (°C) x mass of water (g)**

8 (a) The temperature rise can be calculated using the formula opposite.

Use this formula to calculate the temperature rise recorded by student D. [2 marks]

Temperature rise = \_\_\_\_\_ °C

(b) Plot the energy given out against mass of ethanol burned on **DIAGRAM 16** and draw a suitable line. [3 marks]

(c) Describe the relationship between the mass of ethanol burned and the energy given out. [2 marks]

---

---

---

---

---

---



(d) All the recorded temperature rises were LOWER than expected.

Explain ONE piece of advice you would give the students to resolve this problem.  
[2 marks]

---

---

---

---

---

9



9 Transition metals have the ability to form ions with different charges. Iron and copper are transition metals.

(a) A teacher carried out a series of reactions to show that iron can form  $\text{Fe}^{2+}$  and  $\text{Fe}^{3+}$  ions. This is shown in DIAGRAM 17.

(i) State what you would expect to SEE during the reactions that shows iron is a transition metal. [1 mark]

---

---

(ii) In REACTION 2, iron reacts with iron(III) chloride forming iron(II) chloride,  $\text{FeCl}_2$ .

I. Complete and balance the equation for this reaction. [2 marks]





9 (a)(ii) II.

Explain the meaning of the term **oxidation** in relation to **REACTION 2**. [2 marks]

---

---

---

---

---

(b) Name the reagent used to identify copper(II) ions in solution. Give the observation expected. [2 marks]

Reagent

---

---

Observation

---

---

7

(Turn over)



- 10 (a) Some household cleaners are a concentrated solution of ammonia.

To determine the concentration of an ammonia solution, 10.0 cm<sup>3</sup> of a household cleaner was titrated with dilute sulfuric acid of concentration 1.5 mol/dm<sup>3</sup>.

The end-point was determined by using the indicator methyl orange.

The procedure was repeated three times and the mean volume of dilute sulfuric acid needed to neutralise 10.0 cm<sup>3</sup> of the ammonia solution was found to be 12.0 cm<sup>3</sup>.

- (i) Use the equation below to calculate the number of moles of sulfuric acid in 12.0 cm<sup>3</sup> of the 1.5 mol/dm<sup>3</sup> solution. [2 marks]

$$\text{concentration} = \frac{\text{number of moles}}{\text{volume}}$$

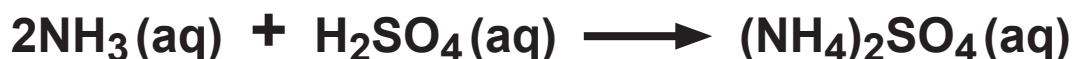
Number of moles of sulfuric acid = \_\_\_\_\_ mol

(Turn over)



10 (a)(ii)

Ammonia solution reacts with sulfuric acid according to the equation below.



Use the equation for the reaction to find the number of moles of ammonia in 10.0 cm<sup>3</sup> of the household cleaner. [1 mark]

Number of  
moles of ammonia = \_\_\_\_\_ mol

(iii) Calculate the concentration of ammonia in mol/dm<sup>3</sup>. [2 marks]

Concentration  
of ammonia = \_\_\_\_\_ mol/dm<sup>3</sup>

(Turn over)



**10 (b) DIAGRAM 18** shows two reactions of dilute hydrochloric acid.

**(i) Predict the temperature change if dilute ethanoic acid,  $\text{CH}_3\text{COOH}$ , is added to sodium hydroxide instead of dilute hydrochloric acid. Give the reason for your answer. [2 marks]**

---

---

---

---

---

**(ii) A salt is formed when ethanoic acid is added to copper(II) carbonate.**

**I. Give the name of the salt. [1 mark]**

---

---



10 (b)(ii) II.

The negative ion present in the salt is  $\text{CH}_3\text{COO}^-$ .

Underline the correct formula of the salt.

[1 mark]



9











<b>Question number</b>	<b>Additional page, if required. Write the question numbers in the left-hand margin.</b>



<b>Question number</b>	<b>Additional page, if required. Write the question numbers in the left-hand margin.</b>



<b>Question number</b>	<b>Additional page, if required. Write the question numbers in the left-hand margin.</b>



<b>Question number</b>	<b>Additional page, if required. Write the question numbers in the left-hand margin.</b>



<b>Question number</b>	<b>Additional page, if required. Write the question numbers in the left-hand margin.</b>



<b>Question number</b>	<b>Additional page, if required. Write the question numbers in the left-hand margin.</b>



<b>Question number</b>	<b>Additional page, if required. Write the question numbers in the left-hand margin.</b>



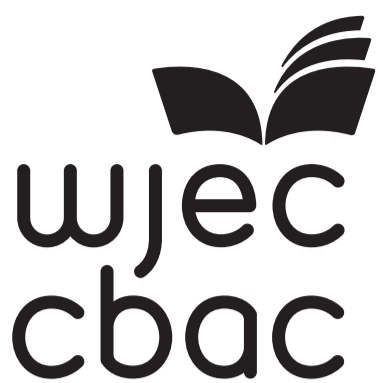
<b>Question number</b>	<b>Additional page, if required. Write the question numbers in the left-hand margin.</b>



<b>Question number</b>	<b>Additional page, if required. Write the question numbers in the left-hand margin.</b>



<b>Question number</b>	<b>Additional page, if required. Write the question numbers in the left-hand margin.</b>



GCSE

3410UB0-1

FRIDAY, 27 MAY 2022 – MORNING

**CHEMISTRY – Unit 2:**

**Chemical Bonding, Application of Chemical Reactions and Organic Chemistry**

**HIGHER TIER**

# Data Booklet



## FORMULAE FOR SOME COMMON IONS

POSITIVE IONS	
Name	Formula
aluminium	$\text{Al}^{3+}$
ammonium	$\text{NH}_4^+$
barium	$\text{Ba}^{2+}$
calcium	$\text{Ca}^{2+}$
copper(II)	$\text{Cu}^{2+}$
hydrogen	$\text{H}^+$
iron(II)	$\text{Fe}^{2+}$
iron(III)	$\text{Fe}^{3+}$
lithium	$\text{Li}^+$
magnesium	$\text{Mg}^{2+}$
nickel	$\text{Ni}^{2+}$
potassium	$\text{K}^+$
silver	$\text{Ag}^+$
sodium	$\text{Na}^+$
zinc	$\text{Zn}^{2+}$

NEGATIVE IONS	
Name	Formula
bromide	$\text{Br}^-$
carbonate	$\text{CO}_3^{2-}$
chloride	$\text{Cl}^-$
fluoride	$\text{F}^-$
hydroxide	$\text{OH}^-$
iodide	$\text{I}^-$
nitrate	$\text{NO}_3^-$
oxide	$\text{O}^{2-}$
sulfate	$\text{SO}_4^{2-}$



# THE PERIODIC TABLE

## KEY

Ar	relative atomic mass
Sym	symbol
Z	atomic number

1 2 GROUP

3 4 5 6 7 0

1	H	1
---	---	---

7	Li	3	9	Be	4	11	B	5	12	C	6	14	N	7	16	O	8	19	F	9	20	Ne	10
23	Na	11	24	Mg	12	27	Al	13	28	Si	14	31	P	15	32	S	16	35.5	Cl	17	40	Ar	18
39	K	19	40	Ca	20	55	Mn	25	52	Cr	24	51	V	23	48	Ti	22	59	Ni	28	63.5	Cu	29
86	Rb	37	88	Sr	38	99	Tc	43	96	Mo	42	93	Nb	41	91	Zr	40	106	Pd	46	108	Ag	47
133	Cs	55	137	Ba	56	186	Re	75	184	W	74	181	Ta	73	179	Hf	72	195	Pt	78	197	Au	79
223	Fr	87	226	Ra	88	227	Ac	89	201	Hg	80	204	Tl	81	207	Pb	82	209	Bi	83	210	Po	84
									112	Cd	48	115	In	49	128	Te	52	127	I	53	131	Xe	54
									65	Zn	30	70	Ga	31	79	Se	34	80	Br	35	84	Kr	36
									103	Rh	45	101	Ru	44	101	Os	76	192	Ir	77	222	Rn	86



## THE PERIODIC TABLE

### PERIODIC TABLE – KEY ATOMIC NUMBER – SYMBOL – NAME

1	H – Hydrogen		39	Y – Yttrium
2	He – Helium		40	Zr – Zirconium
3	Li – Lithium		41	Nb – Niobium
4	Be – Beryllium		42	Mo – Molybdenum
5	B – Boron		43	Tc – Technetium
6	C – Carbon		44	Ru – Ruthenium
7	N – Nitrogen		45	Rh – Rhodium
8	O – Oxygen		46	Pd – Palladium
9	F – Fluorine		47	Ag – Silver
10	Ne – Neon		48	Cd – Cadmium
11	Na – Sodium		49	In – Indium
12	Mg – Magnesium		50	Sn – Tin
13	Al – Aluminium		51	Sb – Antimony
14	Si – Silicon		52	Te – Tellurium
15	P – Phosphorus		53	I – Iodine
16	S – Sulfur		54	Xe – Xenon
17	Cl – Chlorine		55	Cs – Caesium
18	Ar – Argon		56	Ba – Barium
19	K – Potassium		57	La – lanthanum
20	Ca – Calcium		72	Hf – Hafnium
21	Sc – Scandium		73	Ta – Tantalum
22	Ti – Titanium		74	W – Tungsten
23	V – Vanadium		75	Re – Rhenium
24	Cr – Chromium		76	Os – Osmium
25	Mn – Manganese		77	Ir – Iridium
26	Fe – Iron		78	Pt – Platinum
27	Co – Cobalt		79	Au – Gold
28	Ni – Nickel		80	Hg – Mercury
29	Cu – Copper		81	Tl – Thallium
30	Zn – Zinc		82	Pb – Lead
31	Ga – Gallium		83	Bi – Bismuth
32	Ge – Germanium		84	Po – Polonium
33	As – Arsenic		85	At – Astatine
34	Se – Selenium		86	Rn – Radon
35	Br – Bromine		87	Fr – Francium
36	Kr – Krypton		88	Ra – Radium
37	Rb – Rubidium		89	Ac – Actinium
38	Sr – Strontium			



GCSE

3410UB0-1

**FRIDAY, 27 MAY 2022 – MORNING**

## **CHEMISTRY – Unit 2:**

**Chemical Bonding, Application of Chemical Reactions  
and Organic Chemistry**

**HIGHER TIER**

**The Diagram Booklet MUST be handed in  
to the invigilators and sent for marking.**

# **Diagram Booklet**

**Surname** \_\_\_\_\_

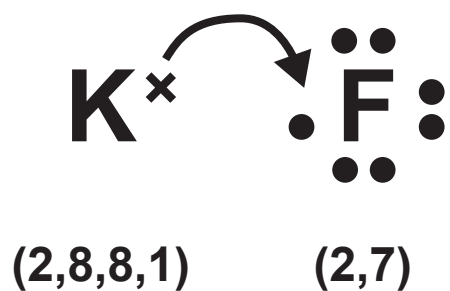
**First name(s)** \_\_\_\_\_

**Centre Number** \_\_\_\_\_

**Candidate Number** 0 \_\_\_\_\_

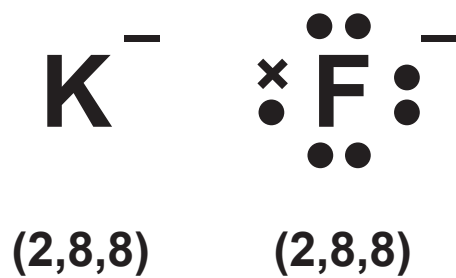


## DIAGRAM 1



## DIAGRAM 2

Student's answer



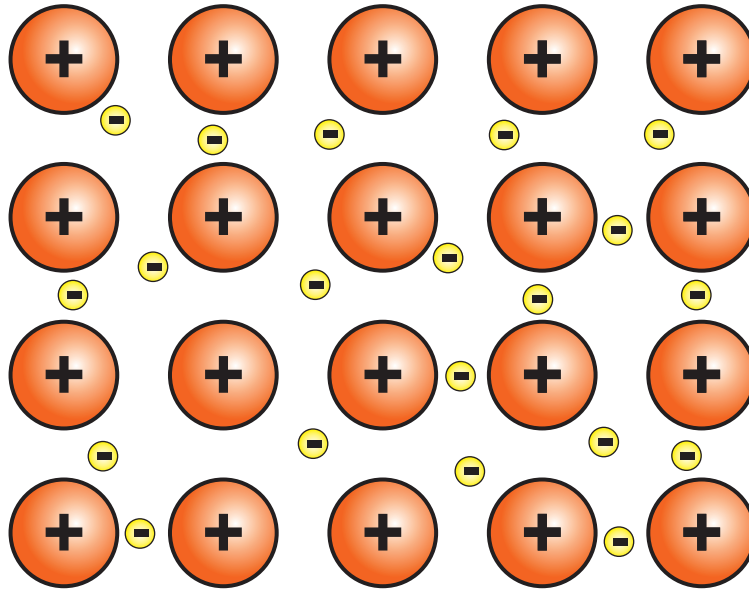


**THIS IS A BLANK PAGE**

**TURN OVER**

# DIAGRAM 3

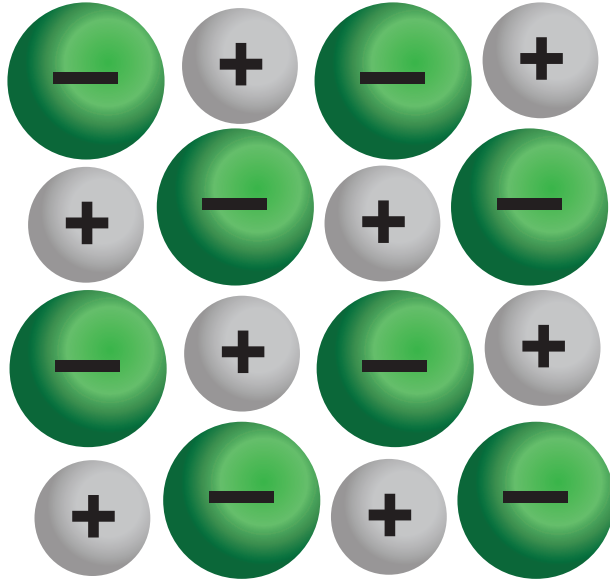
## A



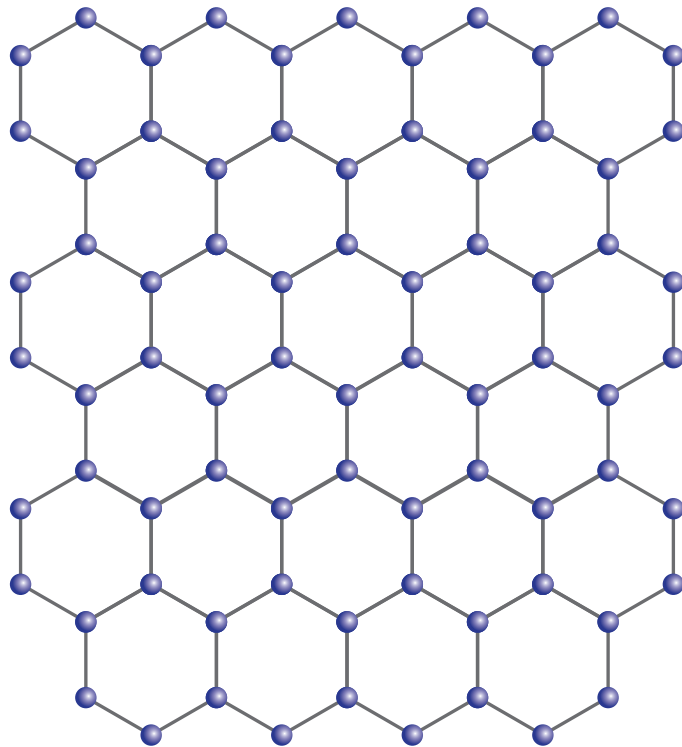
## B



C

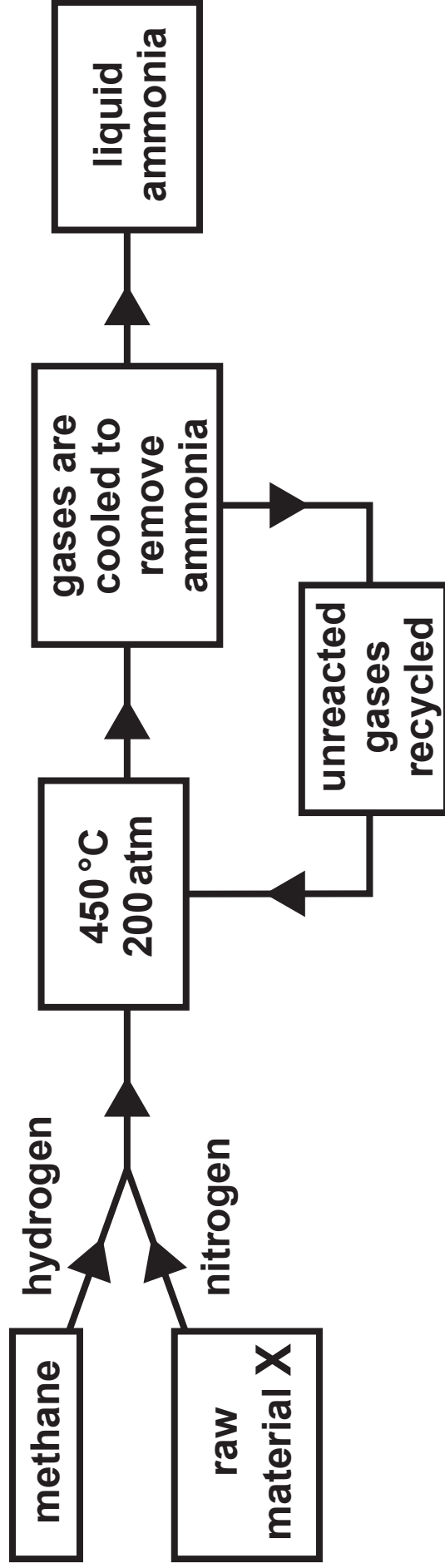


D



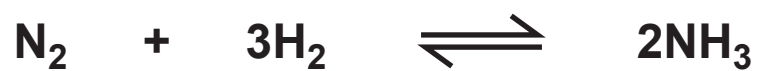


**DIAGRAM 4**





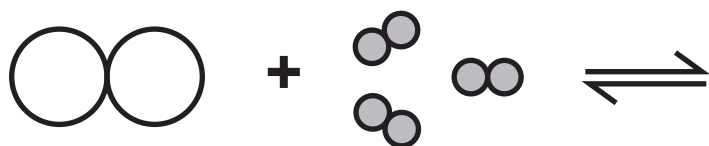
## DIAGRAM 5



## DIAGRAM 6

Key:  nitrogen gas, N<sub>2</sub>

 hydrogen gas, H<sub>2</sub>





6



+

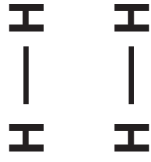
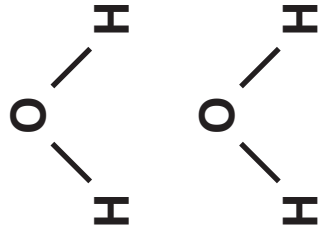
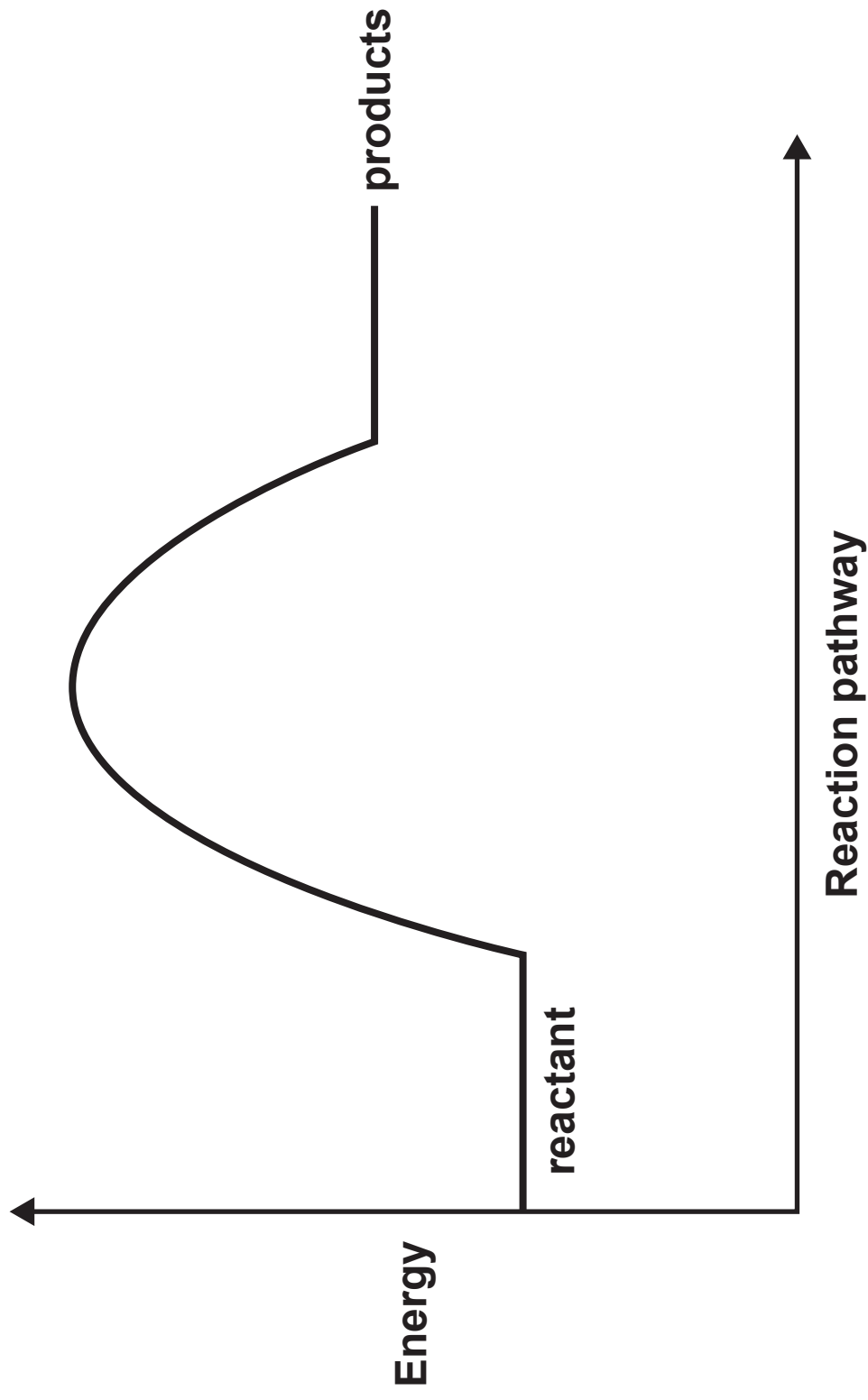


DIAGRAM 7





**DIAGRAM 8**



Energy

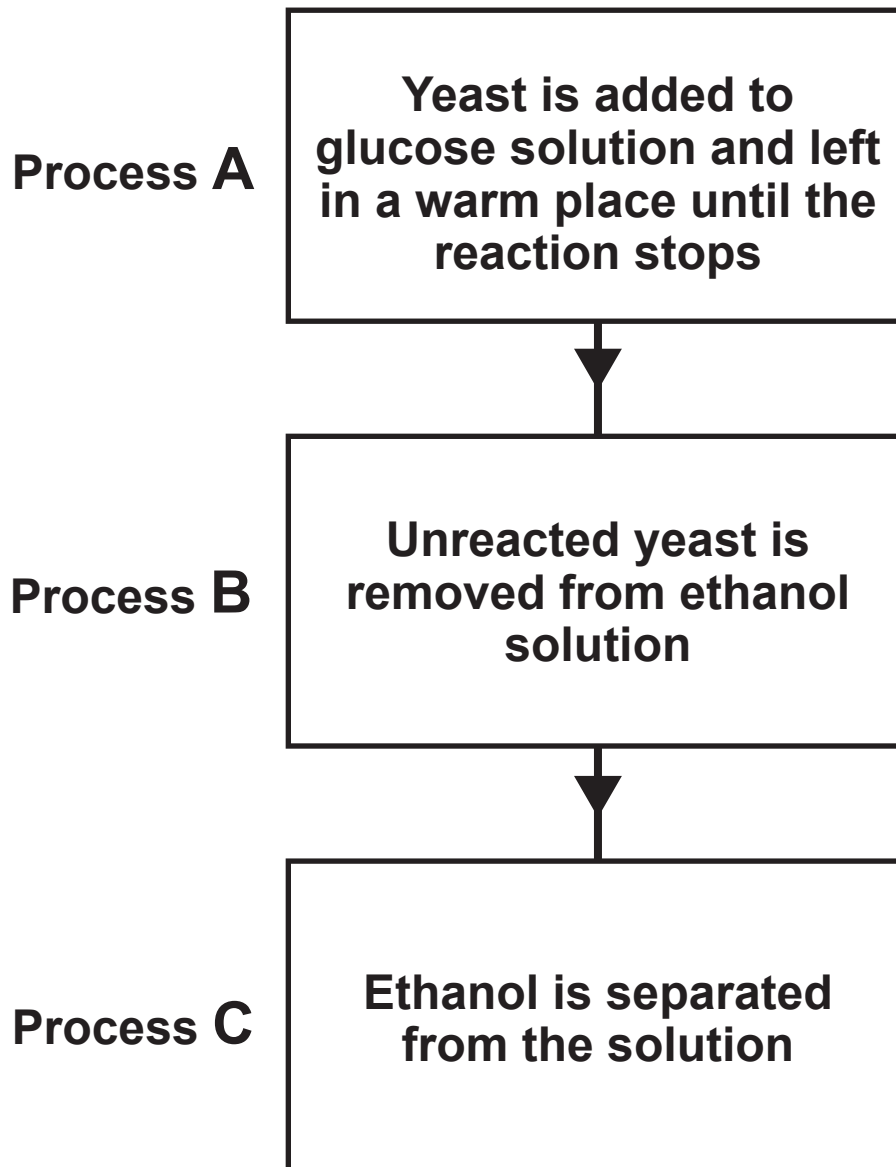
reactant

products

Reaction pathway

7



**DIAGRAM 9**



**THIS IS A BLANK PAGE**

**TURN OVER**

# DIAGRAM 10A

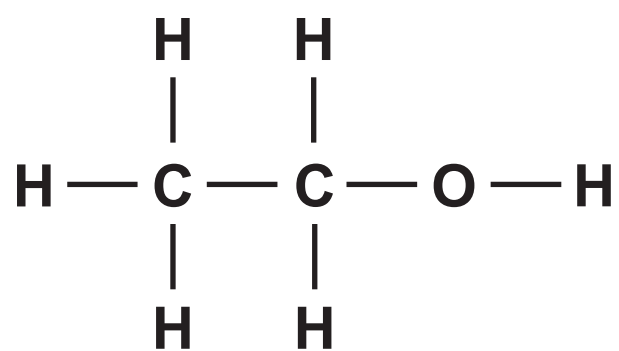
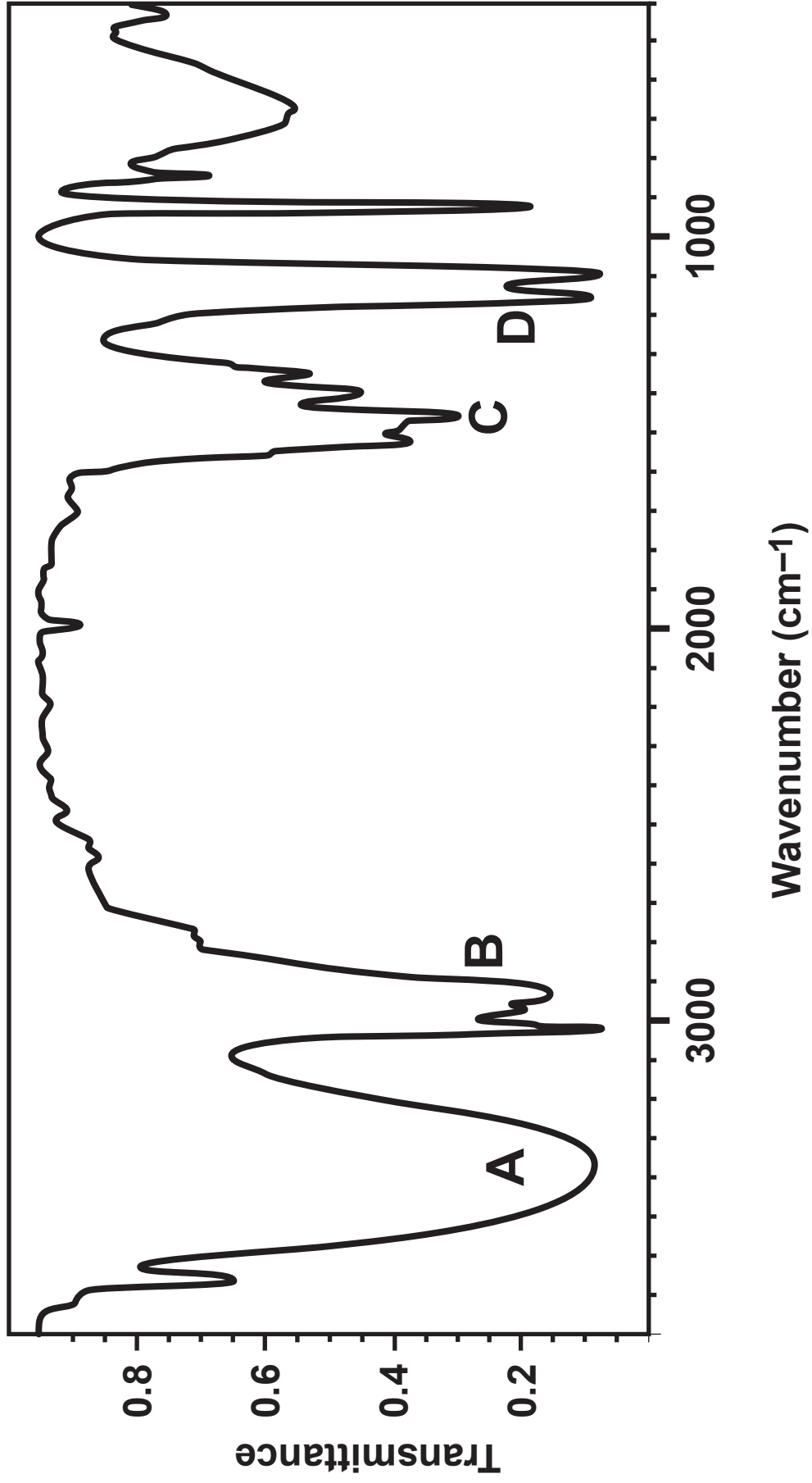


DIAGRAM 10B





**THIS IS A BLANK PAGE**

**TURN OVER**

# DIAGRAM 11A

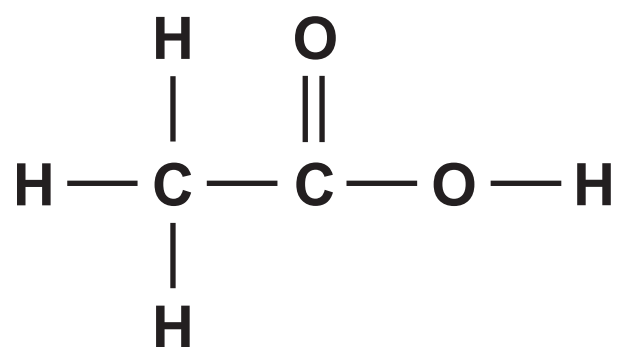
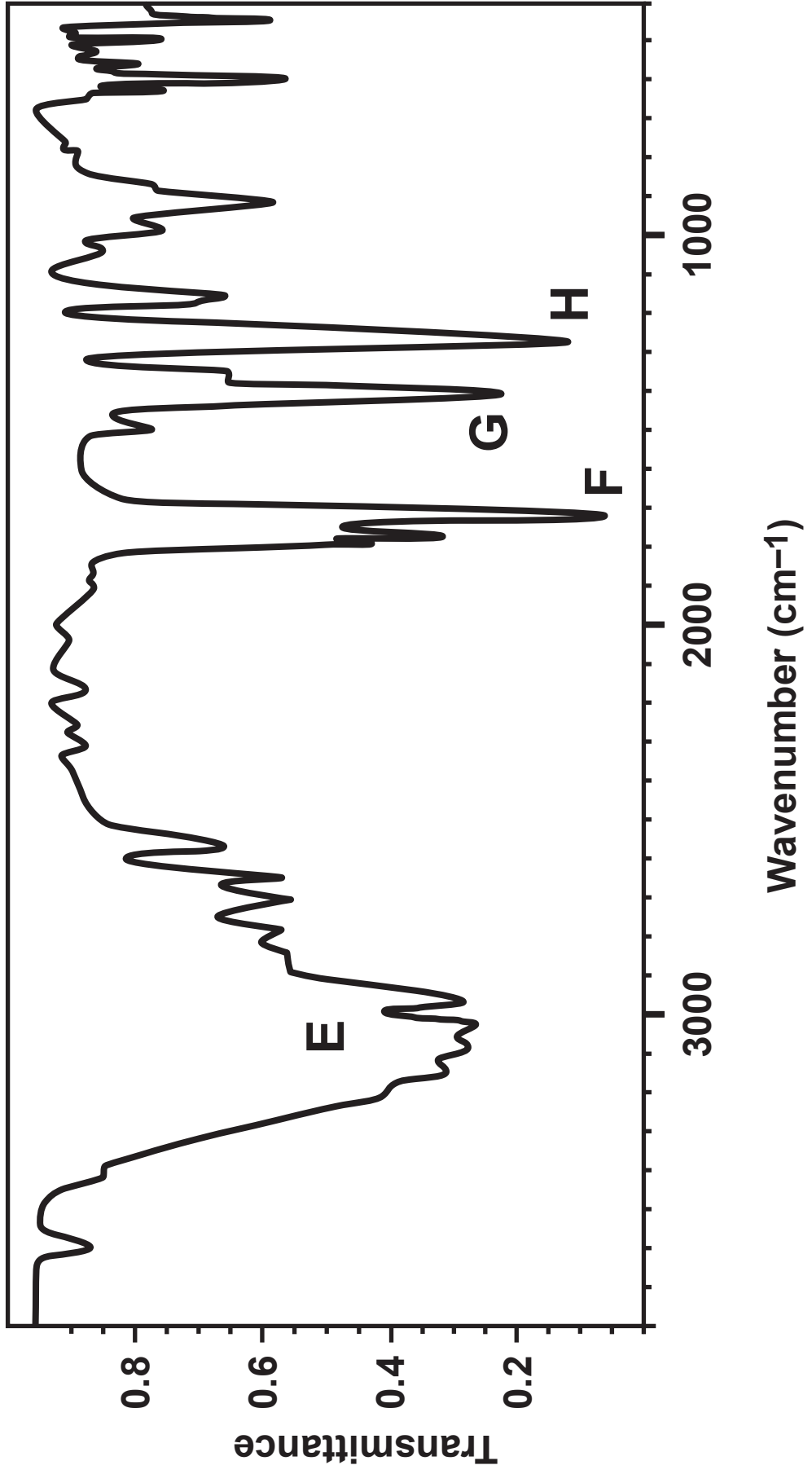


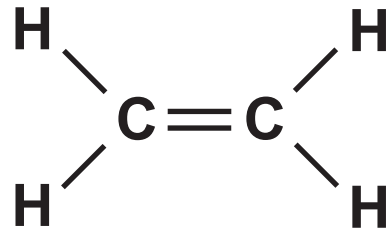
DIAGRAM 11B







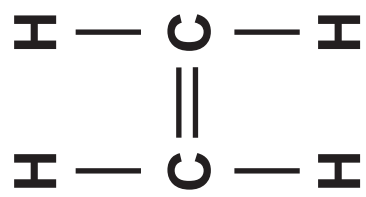


**DIAGRAM 13****ethene**

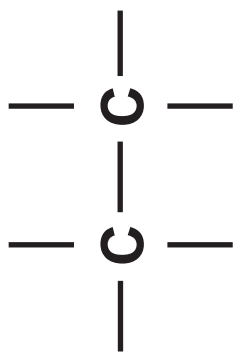
**repeating unit for polyethene**



DIAGRAM 14



+





**DIAGRAM 15**

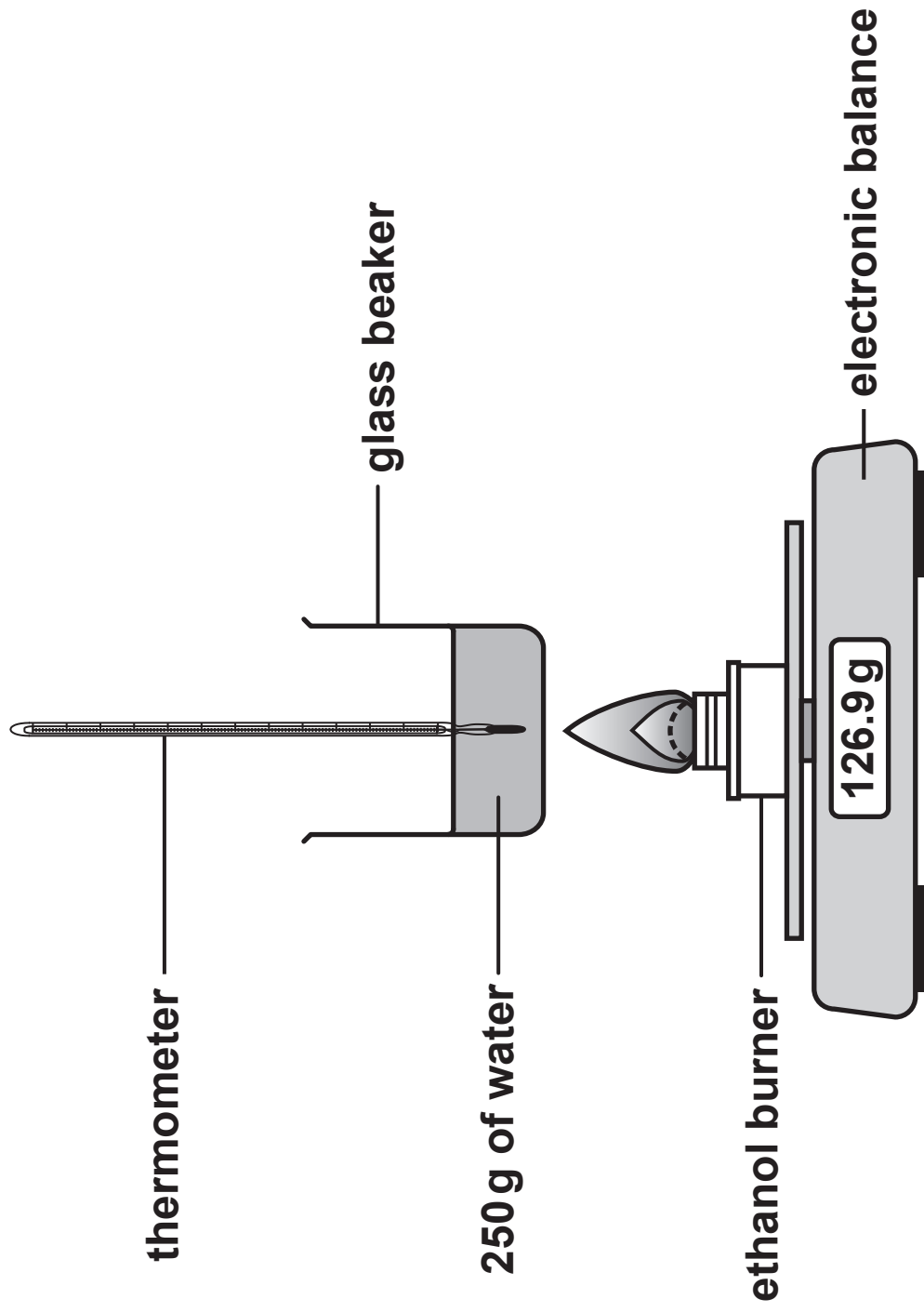
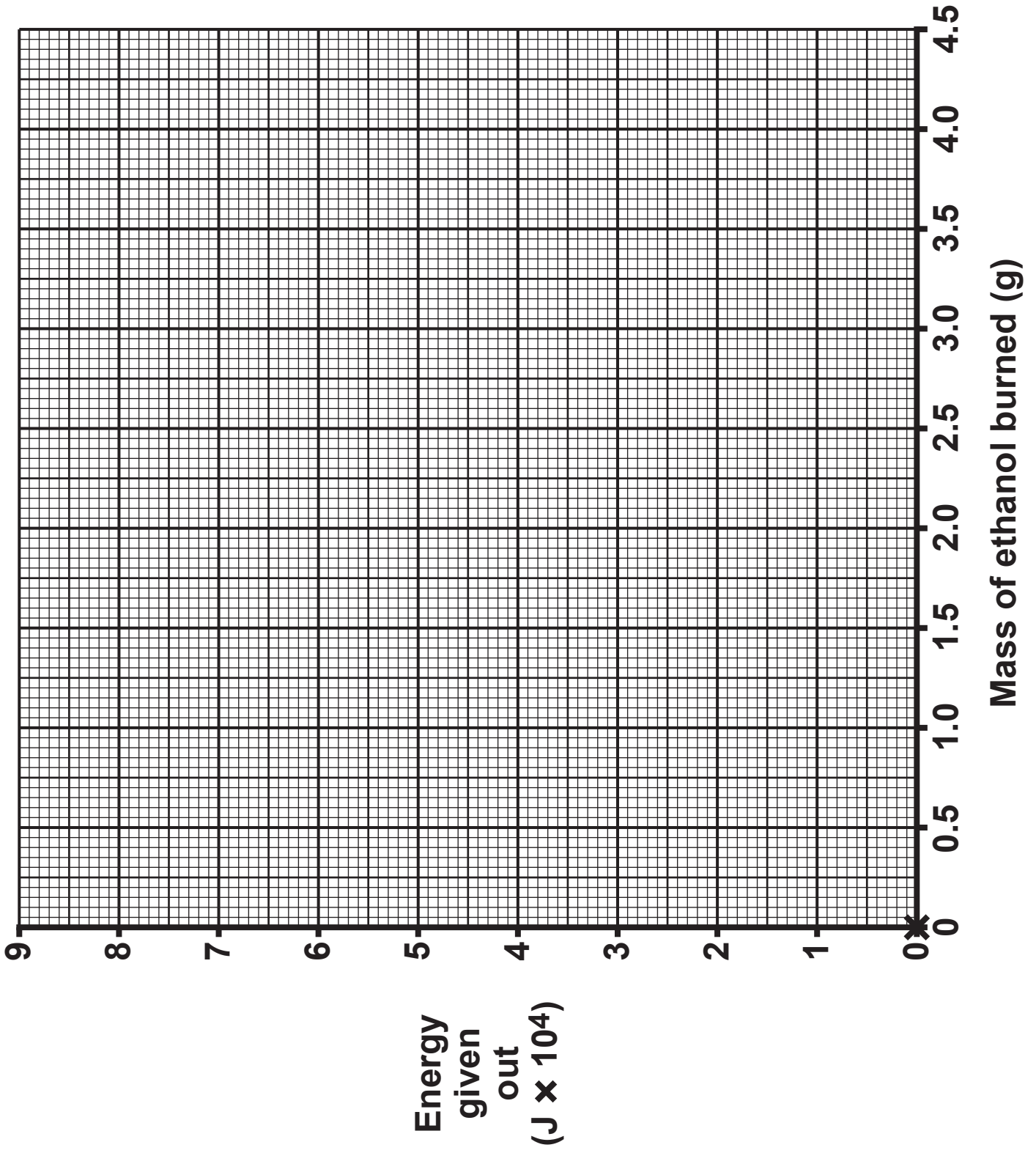




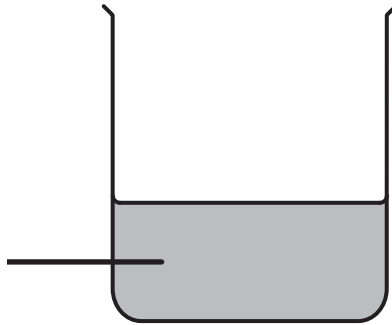
DIAGRAM 16





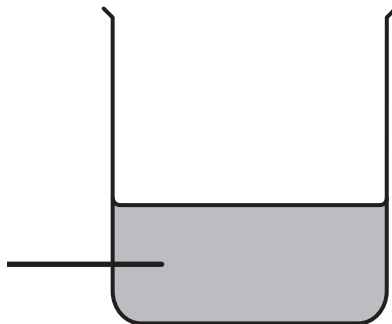
**DIAGRAM 17**

**freshly made  
iron(II) chloride  
solution**



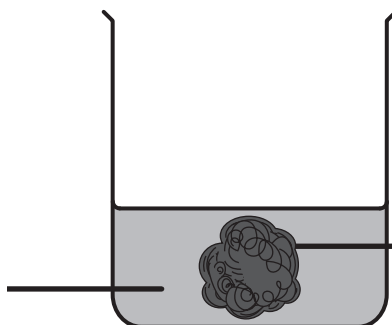
**REACTION 1**  
Iron(II) chloride solution  
is allowed to stand for  
2 hours

**iron(III)  
chloride  
solution**



**REACTION 2**  
Excess iron wool is added  
to iron(III) chloride solution

**iron(II)  
chloride  
solution**



**unreacted  
iron wool**



**DIAGRAM 18**

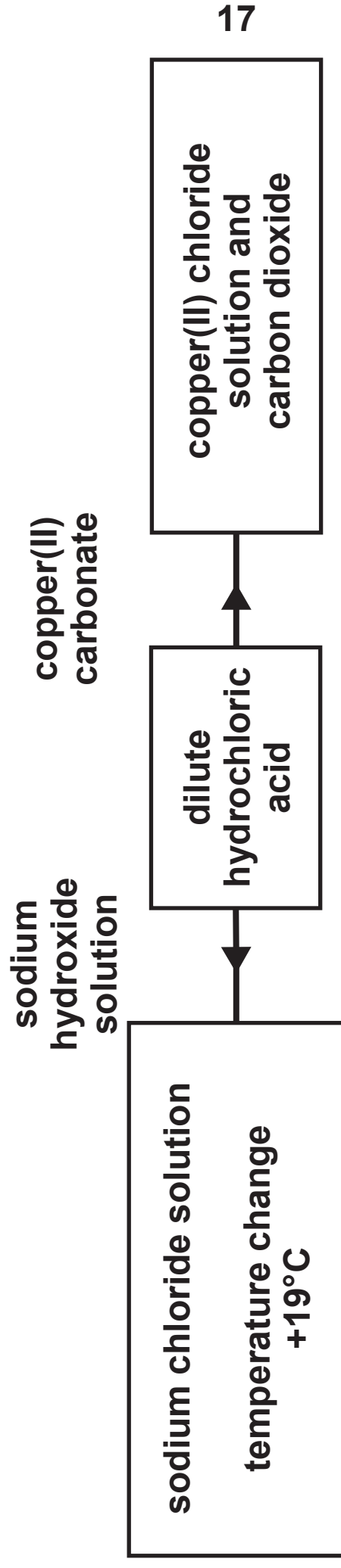




DIAGRAM 19

