

**GCSE 3300U40-1**



**MATHEMATICS**

**UNIT 2: CALCULATOR – ALLOWED**

**INTERMEDIATE TIER**

**THURSDAY, 6 JUNE**

**2019 – MORNING**

**1 hour 45 minutes**

**(plus your additional  
time allowance)**

**A CALCULATOR  
WILL BE REQUIRED  
FOR THIS PAPER**

For Examiner's use only		
Question	Maximum Mark	Mark Awarded
1.	6	
2.	5	
3.	4	
4.	5	
5.	7	
6.	4	
7.	5	
8.	4	
9.	8	
10.	4	
11.	2	
12.	3	
13.	4	
14.	3	
15.	5	
16.	4	
17.	3	
18.	4	
<b>Total</b>	<b>80</b>	

<b>Surname:</b>	
<b>Other Names:</b>	
<b>Centre Number:</b>	
<b>Candidate Number:</b>	<b>0</b>

**ADDITIONAL MATERIALS**

**A ruler, a protractor and a pair of compasses may be required.**

**ITEMS INCLUDED WITH QUESTION PAPER**

**A separate Formula List.**

**A separate Diagram Booklet.**

**A spare Diagram Booklet.**

**(Turn over)**

**INSTRUCTIONS TO CANDIDATES**

**Use black ink, black ball – point pen, black felt tip or your usual method.**

**Write your name, centre number and candidate number in the spaces on the front cover.**

**Answer ALL questions.**

**Write your answers in the spaces provided.**

**If you run out of space, use the continuation pages at the back of the booklet. Question numbers must be given for all work written on the continuation page(s).**

**Take  $\pi$  as 3.14 or use the  $\pi$  button on your calculator.**

**(Turn over)**

**INFORMATION FOR CANDIDATES**

**You should give details of your method of solution when appropriate.**

**Unless stated, diagrams are not drawn to scale.**

**Scale drawing solutions will not be acceptable where you are asked to calculate.**

**The number of marks is given in brackets at the end of each question or part – question.**

**In question 5, the assessment will take into account the quality of your linguistic and mathematical organisation, communication and accuracy in writing.**

**(Turn over)**

1. (a) Calculate each of the following.

(i)  $4.8^2 + \sqrt{28.09}$

---

---

---

---

---

---

---

---

[2 marks]

continued on the next page . . .

(Turn over)

**Question 1 (a) continued**

**1. (a) (ii)  $\frac{4}{9}$  of 78.3**

---

---

---

---

---

---

---

**[1 mark]**

**continued on the next page . . .**

**(Turn over)**

**Question 1 (a) continued**

**1. (a) (iii)  $1000 \times$  (the reciprocal of 8)**

---

---

---

---

---

---

---

---

**[2 marks]**

**continued on the next page . . .**

**(Turn over)**

**Question 1 continued**

- 1. (b) Write 437.6 correct to  
2 significant figures.**

---

---

---

**[1 mark]**

**(Turn over)**

2. (a) Find the value of  $5f + 7g$   
when  $f = 3.8$  and  $g = -2.6$

---

---

---

---

---

---

---

---

---

---

[2 marks]

continued on the next page . . .

(Turn over)

**Question 2 continued**

- 2. (b) Solve the following equation.  
Give your answer correct to  
1 decimal place.**

$$7x - 4 = 12$$

---

---

---

---

---

---

---

---

---

---

**(Turn over)**

---

---

---

---

**[3 marks]**

**(Turn over)**

3. (a) Circle the longest time period from the list given below.

180 minutes
4.5 hours
4 hours 45 minutes
$4\frac{1}{4}$ hours
$\frac{1}{6}$ th of a day

---

---

---

---

(Turn over)

---

---

[1 mark]

3. (b) Circle the longest distance from the list given below.

30 000 mm
250 m
2 km 70 m
4 000 cm
2.4 km

---

---

(Turn over)

---

---

---

---

**[1 mark]**

**continued on the next page . . .**

**(Turn over)**

**Question 3 continued**

**3. (c) Look at the statements for Question 3 (c) in the separate Diagram Booklet.**

**Circle either TRUE or FALSE for each statement given.**

---

---

---

---

---

---

---

---

**[2 marks]**

**(Turn over)**

4. **Catrin makes the following statement.**

**If you double the length of each side of a rectangle, you will double its perimeter and also double its area.**

**Is Catrin correct?**

**SHOW CLEARLY, using an example, how you came to your decision.**

**[5 marks]**

---

---

---

**(Turn over)**



---

---

---

---

---

---

---

---

---

---

---

---

---

---

---

---

---

---

---

---

---

---

---

---



**5. IN THIS QUESTION, YOU WILL BE ASSESSED ON THE QUALITY OF YOUR ORGANISATION, COMMUNICATION AND ACCURACY IN WRITING.**

**18% of £256 is shared in the ratio 2 : 1**

**Calculate the value of the larger share.**

**Give your answer to the nearest 10p.**

**You must show all your working.**

---

---

---

**(Turn over)**



---

---

---

---

---

---

---

---

---

---

---

---

---

---

---

---

**[5 marks + 2 marks OCW]**

**(Turn over)**

6. (a) Factorise  $7cd + 11c$

---

---

---

---

[1 mark]

(b) Factorise  $x^2 - 8x$

---

---

---

---

[1 mark]

(Turn over)

**Question 6 continued****6. (c) Expand  $4y(2 - 3y)$** 

---

---

---

---

**[2 marks]****(Turn over)**

7. (a) Look at the diagram for Question 7 (a) in the separate Diagram Booklet.

The diagram is NOT drawn to scale.

The diagram shows two congruent triangles.

The coordinates of each vertex are shown.

Find the value of  $e$  and the value of  $f$ .

---

---

---

---

(Turn over)

---

---

---

---

---

---

---

---

***e*** = \_\_\_\_\_

***f*** = \_\_\_\_\_

**[2 marks]**

**continued on the next page . . .**

**(Turn over)**

**Question 7 continued**

- 7. (b) On the grid provided for Question 7 (b) in the separate Diagram Booklet, draw an enlargement of the rectangle, using a scale factor of 3 and centre (1, 2)**

**[3 marks]**

**(Turn over)**

**8. Look at the diagram for Question 8 in the separate Diagram Booklet.**

**Alison and Sarfraz play a game.**

**They each have a different bag of cards.**

**Alison has cards spelling**

**C A E R N A R F O N** in her bag.

**Sarfraz has cards spelling**

**A B E R** in his bag.

**They each take a card at random from their own bag.**

**They make a note of the letter, and return the card to the bag.**

**They each do this 100 times.**

**(Turn over)**

**Question 8 continued**

**Who do you think is likely to choose the letter R more often?**

**Alison**

**Sarfraz**

**You must explain your decision and show all your working.**

---

---

---

---

---

---

---

---

**(Turn over)**



---

---

---

---

---

---

---

---

---

---

**[4 marks]**

**(Turn over)**

9. (a) Write down the  $n$ th term of the following sequence.

8, 11, 14, 17, .....

---

---

---

---

---

---

---

---

[2 marks]

continued on the next page . . .

(Turn over)



**Question 9 continued**

**9. (c) A rectangle has  
a length of  $(x + 5)$  cm and  
a width of  $(2x - 3)$  cm.  
Its perimeter is 46 cm.**

**Calculate the value of  $x$ .**

---

---

---

---

---

---

---

---

---

---

**(Turn over)**

---

---

---

---

---

---

---

---

**[4 marks]**

**(Turn over)**

**10. Look at the diagram for Question 10 in the separate Diagram Booklet.**

**The diagram is NOT drawn to scale.**

**In triangle  $XYZ$ ,**

$$XY = 25.6 \text{ cm}$$

$$XZ = 12.8 \text{ cm}$$

$$ZY = 22.7 \text{ cm}$$

**Is it possible to draw a  
RIGHT – ANGLED triangle with  
the measurements shown  
in the diagram?**

**You must use calculations  
(not a scale drawing) to support  
your answer.**

**You must show all your working.**

**(Turn over)**





---

---

---

**[4 marks]**

**(Turn over)**

11. (a) Look at the diagram for Question 11 (a) in the separate Diagram Booklet.

The diagram is a Venn Diagram.

Which of the following sets represents the SHADED area in the Venn Diagram shown?  
Circle your answer.

$A'$	$A \cup B$	$B'$
$A \cap B$	$A' \cap B$	$A \cup B'$

[1 mark]

continued on the next page . . .

(Turn over)

**Question 11 continued**

**11. (b) Look at the diagram for Question 11 (b) in the separate Diagram Booklet.**

**The diagram is a Venn Diagram.**

**Which of the following sets represents the SHADED area in the Venn Diagram shown?  
Circle your answer.**

$A'$	$A \cup B$	$B'$
$A \cap B$	$A' \cap B$	$A \cup B'$

**[1 mark]**

**(Turn over)**

**12. Look at the following set of four numbers.**

**5    8    10    13**

**Find another set of four numbers so that:**

- the range has increased by 2**
- the mean remains the same**
- the median has decreased by 1**

**You may use some of the numbers from the original set, but NOT exactly the same four numbers.**

---

---

---



---

---

---

---

---

---

---

---

---

---

---

---

---

---

---

---

**My four numbers are**

--	--	--	--

**[3 marks]**  
**(Turn over)**

**13. Look at the diagram for Question 13 in the separate Diagram Booklet.**

**The diagram shows two pie charts.**

**A company has 3 sites based in Wales. One is in Carno, one is in Holyhead and one is in Porth.**

**The pie charts show the distribution of its 128 female staff and 72 male staff.**

**A person is chosen at random from the company's 200 staff members.**

**What is the probability that this person works at the Porth site?**

---

---

**(Turn over)**



---

---

---

---

---

---

---

---

---

---

---

---

---

---

---

---

---

---

---

---

---

---

---

---

**[4 marks]**  
**(Turn over)**

**14. Look at the diagram for Question 14 in the separate Diagram Booklet. The diagram is NOT drawn to scale.**

***PQR* is a right – angled triangle.**

***PR* = 16.7 cm,**

***QR* = 9.6 cm.**

**Calculate the size of angle *QPR*.**

---

---

---

---

---

---

---

---

**(Turn over)**



**50**

---

---

---

**[3 marks]**

**(Turn over)**

**15. The Morgan family and the Smith family are on holiday in Aberystwyth. There are 7 adults and 2 children in the Morgan family. There are 4 adults and 3 children in the Smith family.**

**Both families visit a Craft Centre.**

**The entry price to the Craft Centre is £ $x$  for adults and £ $y$  for children.**

**The total cost for the**

**Morgan family is £41.50**

**The total cost for the**

**Smith family is £29.75**

**continued on the next page . . .**

**(Turn over)**

**Question 15 continued**

**Form two equations in terms of  $x$  and  $y$ .**

**Solve your equations, using an algebraic method, to find the entry price for adults and the entry price for children.**

---

---

---

---

---

---

---

---

**(Turn over)**

---

---

---

---

---

---

---

---

---

---

---

---

---

---

---

---

**(Turn over)**



---

---

---

---

---

---

---

---

**The adult entry price (£ $x$ ) =**

**£** \_\_\_\_\_

**The child entry price (£ $y$ ) =**

**£** \_\_\_\_\_

**[5 marks]**

**(Turn over)**

**16. A solution of the equation**

$$2x^3 + x - 10 = 0$$

**lies between 1 and 2**

**Use the method of trial and improvement to find this solution correct to 1 decimal place.**

**You must show all your working.**

**[4 marks]**

---

---

---

---

---

---

**(Turn over)**









**61**

---

---

---

**[3 marks]**

**(Turn over)**

18. Look at the diagram for Question 18 in the separate Diagram Booklet. The diagram is NOT drawn to scale.

***ABCD*** is a cyclic quadrilateral in a circle with centre ***O***.

Angle ***ABC*** =  $126^\circ$

Write down the size of each of the angles ***x*** and ***y***.

You must give a reason for each of your answers.

***x*** = \_\_\_\_\_<sup>o</sup>

Reason: \_\_\_\_\_

---

(Turn over)

---

---

$y =$  \_\_\_\_\_  $^{\circ}$

**Reason:** \_\_\_\_\_

---

---

---

**[4 marks]**

---

**END OF PAPER**

**TOTAL 80 MARKS**

---

**(Turn over)**







<b>Question number</b>	<b>Additional pages, if required. Write the question number(s) in the left - hand margin.</b>

**GCSE**

**3300U40-1**



**MATHEMATICS**

**UNIT 2: CALCULATOR – ALLOWED**

**INTERMEDIATE TIER**

**THURSDAY, 6 JUNE 2019 – MORNING**

# **Diagram Booklet**

<b>Surname:</b>	
<b>Other Names:</b>	
<b>Centre Number:</b>	
<b>Candidate Number:</b>	<b>0</b>

### Question 3 (c)

### Statements

<b>STATEMENT</b>		
<b>7 kilometres is less than 5 miles</b>	<b>TRUE</b>	<b>FALSE</b>
<b>1 kilogram is less than 2 pounds (lb)</b>	<b>TRUE</b>	<b>FALSE</b>
<b>1 litre is less than 1 pint</b>	<b>TRUE</b>	<b>FALSE</b>
<b>8 litres is less than 900 cm<sup>3</sup></b>	<b>TRUE</b>	<b>FALSE</b>

# Question 7 (a)

Diagram NOT drawn to scale

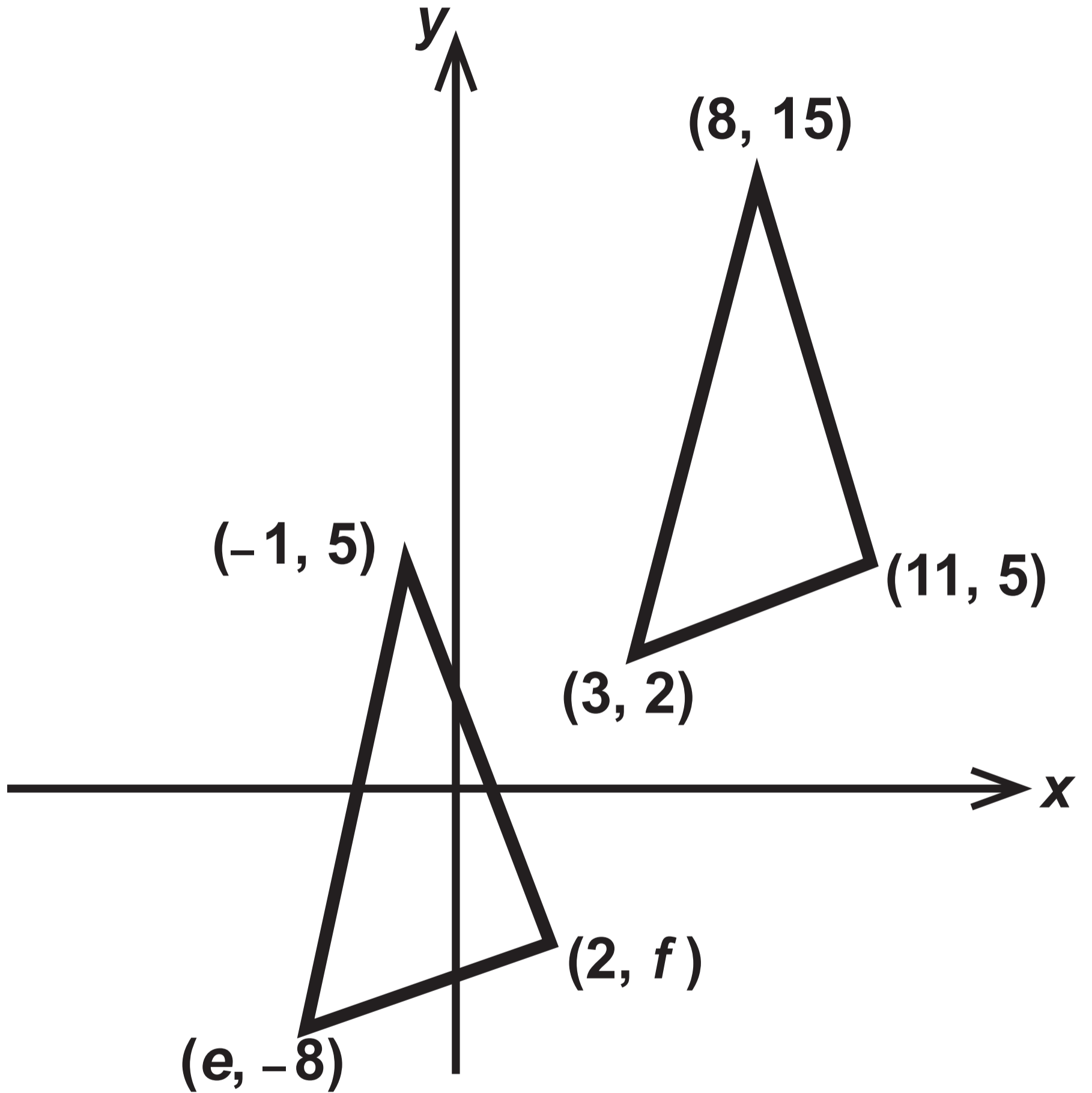

# Question 7 (b)

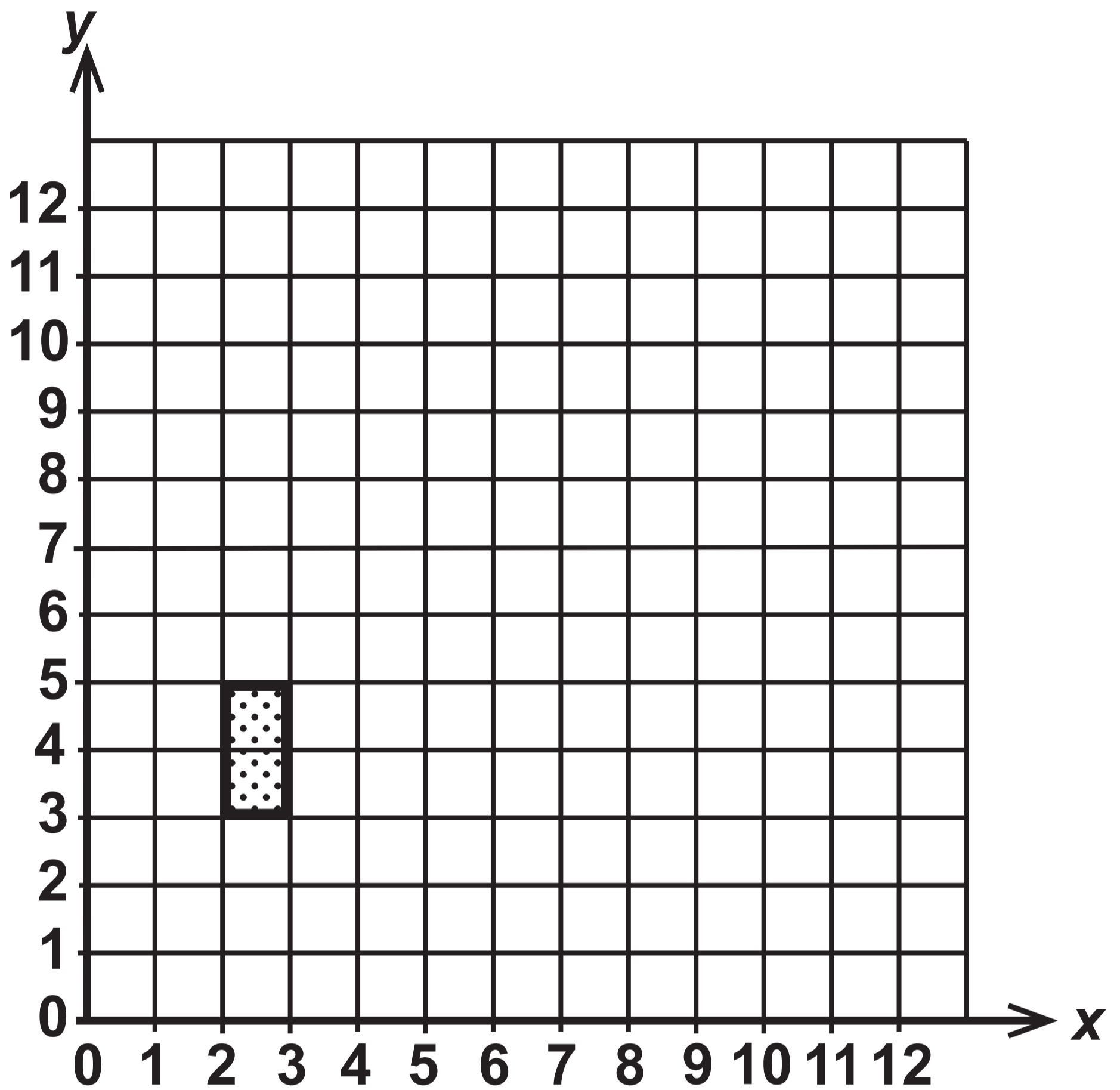

## Question 8

**Alison's cards**

**C A E R N A R F O N**

**Sarfraz's cards**

**A B E R**

## Question 10

Diagram NOT drawn to scale

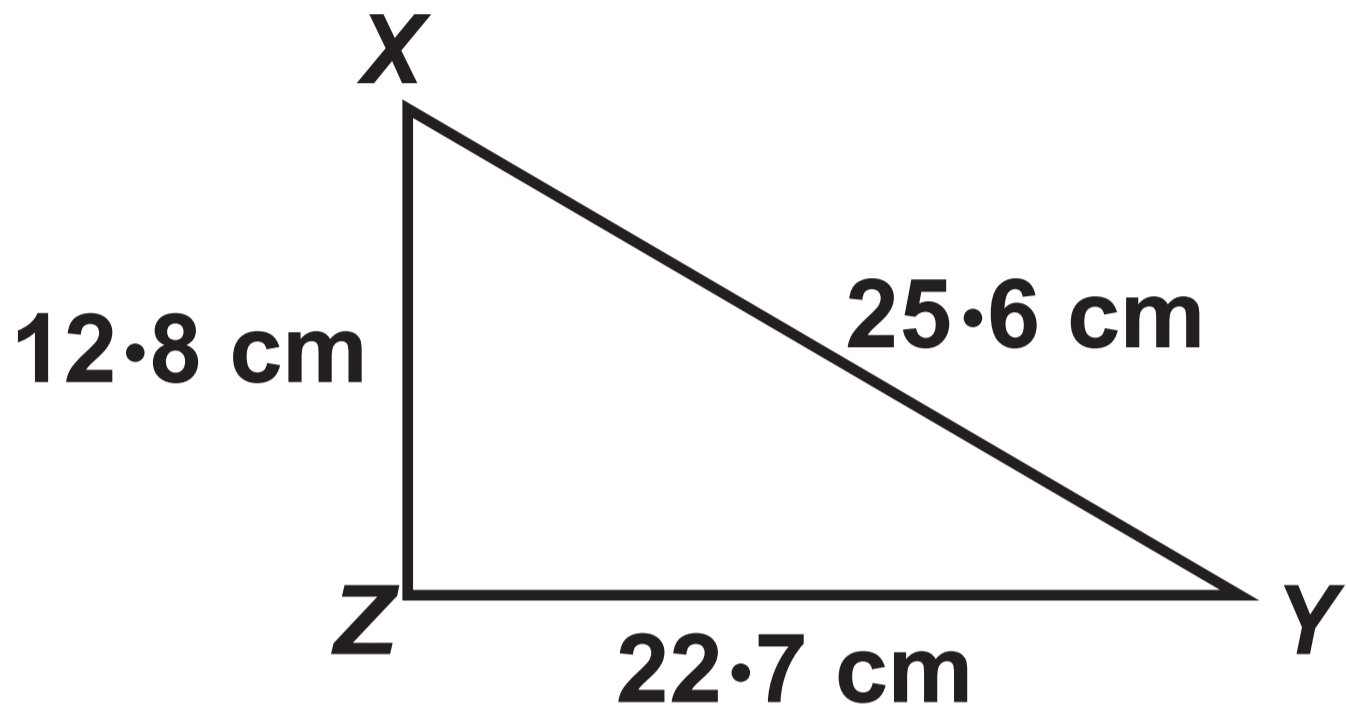

# Question 11 (a)

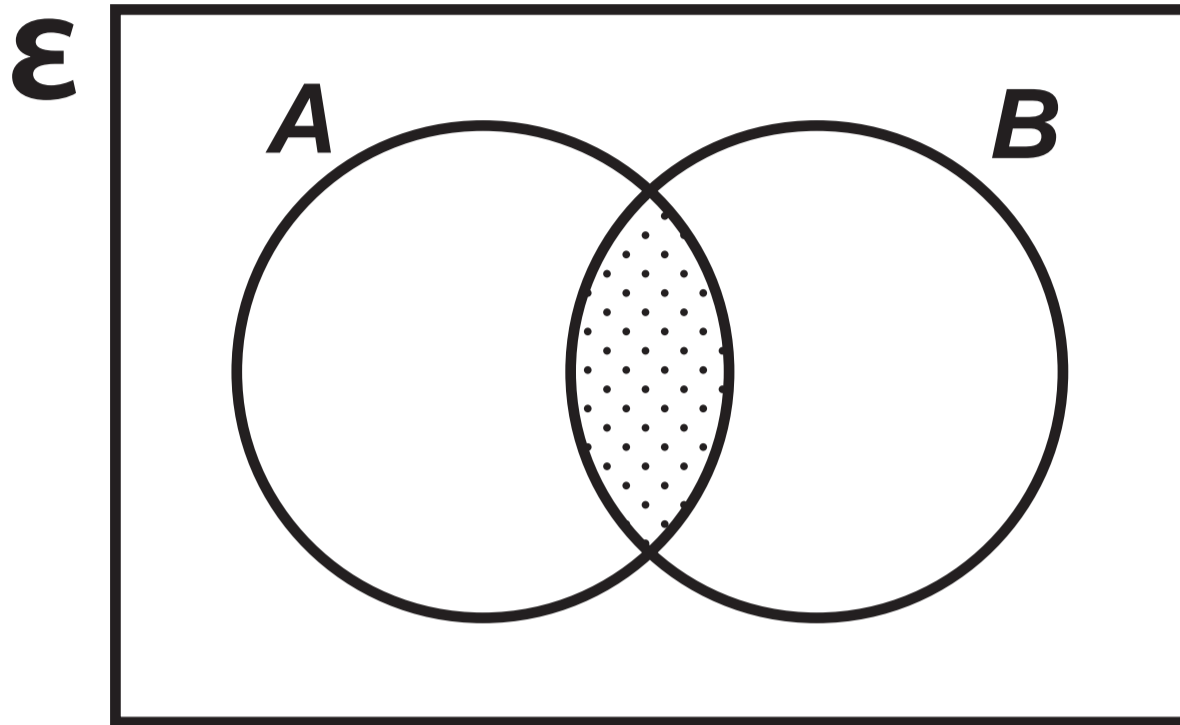

# Question 11 (b)

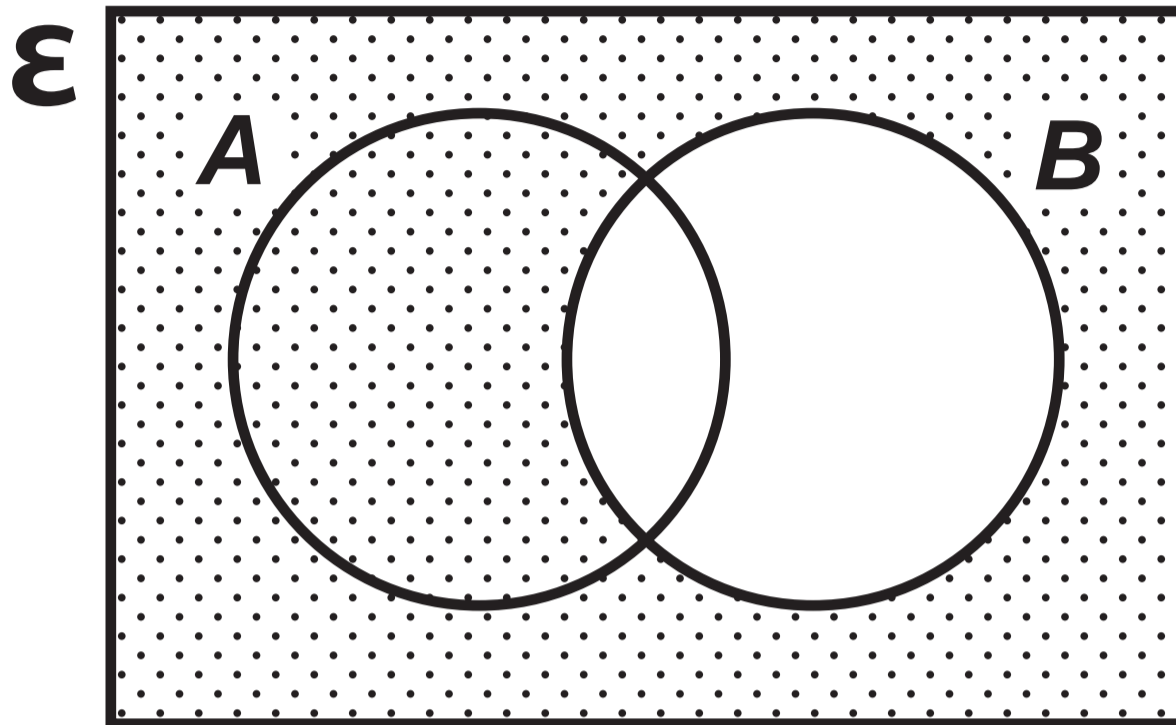

# Question 13

**Pie chart 1**  
**128 female staff**

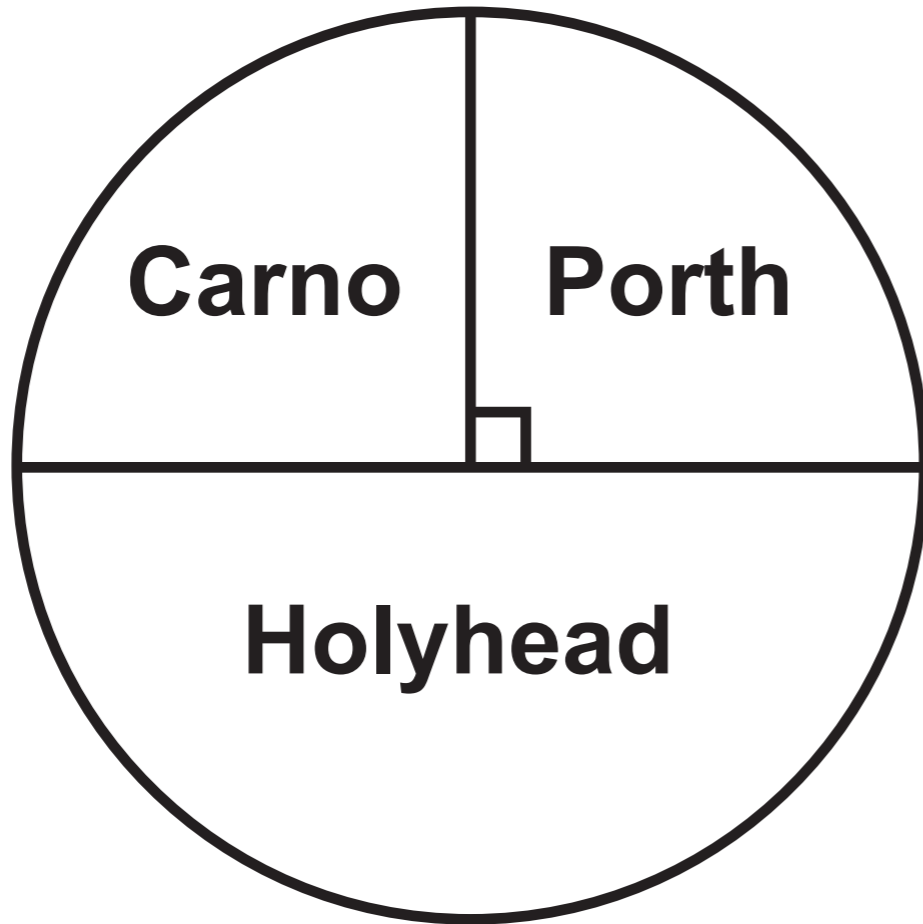

**Pie chart 2**  
**72 male staff**

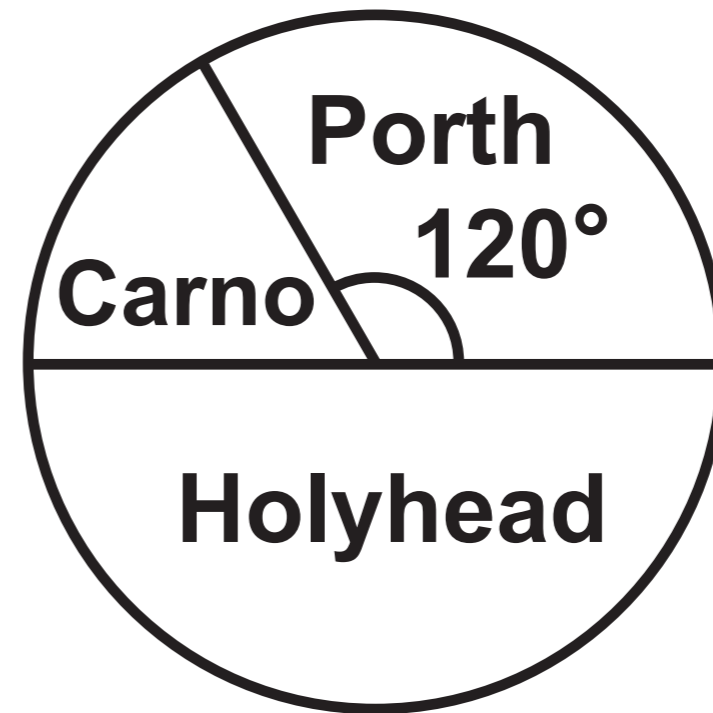

## Question 14

Diagram NOT drawn to scale

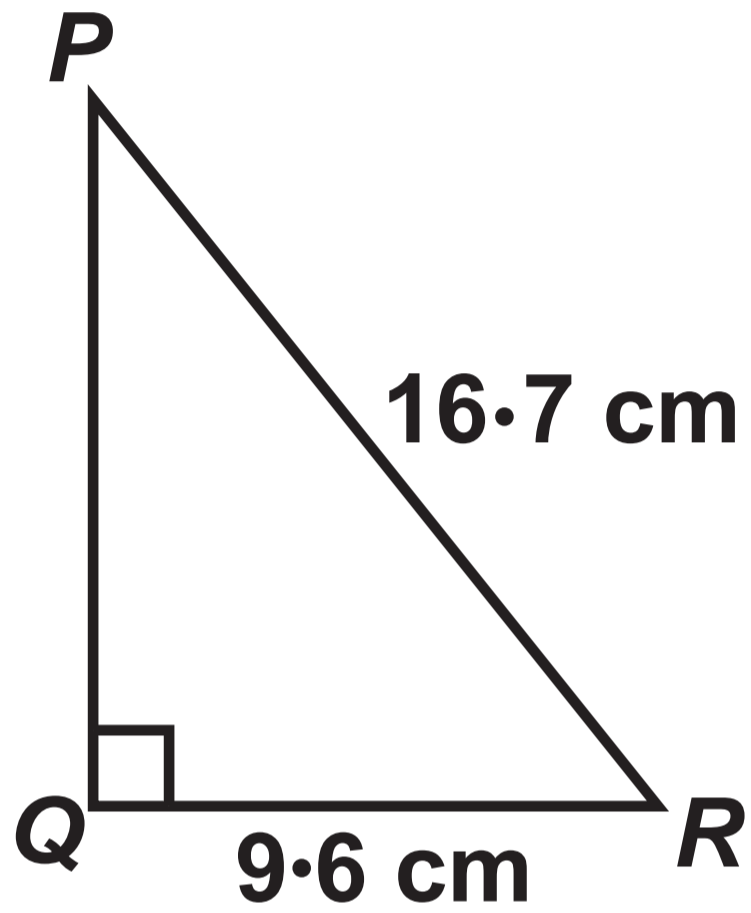

# Question 18

Diagram NOT drawn to scale

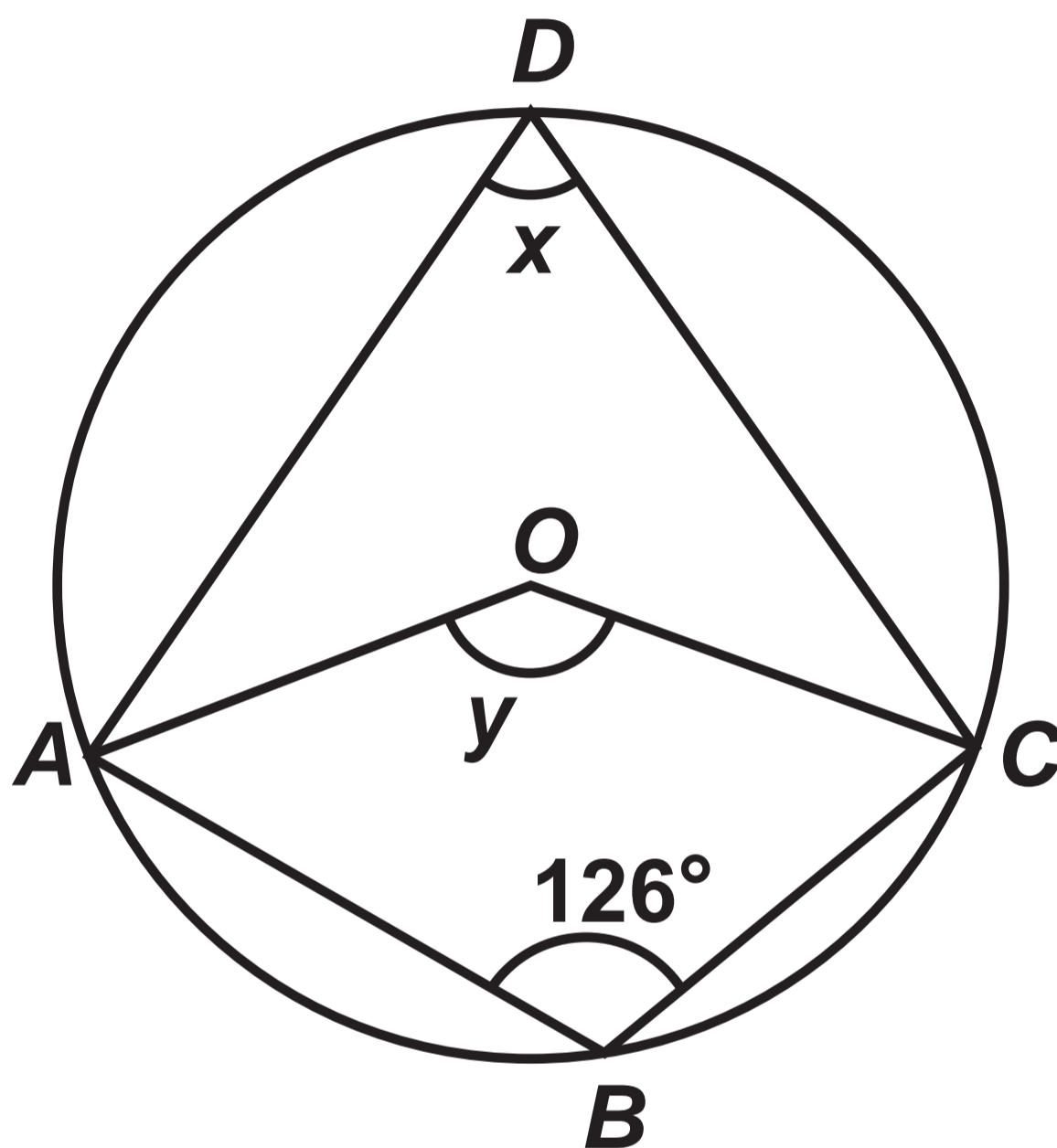

**GCSE**

**3300U40-1**



**MATHEMATICS**

**UNIT 2: CALCULATOR – ALLOWED**

**INTERMEDIATE TIER**

**THURSDAY, 6 JUNE 2019 – MORNING**

# **Spare Diagram Booklet**

<b>Surname:</b>	
<b>Other Names:</b>	
<b>Centre Number:</b>	
<b>Candidate Number:</b>	<b>0</b>

### Question 3 (c)

### Statements

<b>STATEMENT</b>		
<b>7 kilometres is less than 5 miles</b>	<b>TRUE</b>	<b>FALSE</b>
<b>1 kilogram is less than 2 pounds (lb)</b>	<b>TRUE</b>	<b>FALSE</b>
<b>1 litre is less than 1 pint</b>	<b>TRUE</b>	<b>FALSE</b>
<b>8 litres is less than 900 cm<sup>3</sup></b>	<b>TRUE</b>	<b>FALSE</b>

# Question 7 (a)

Diagram NOT drawn to scale

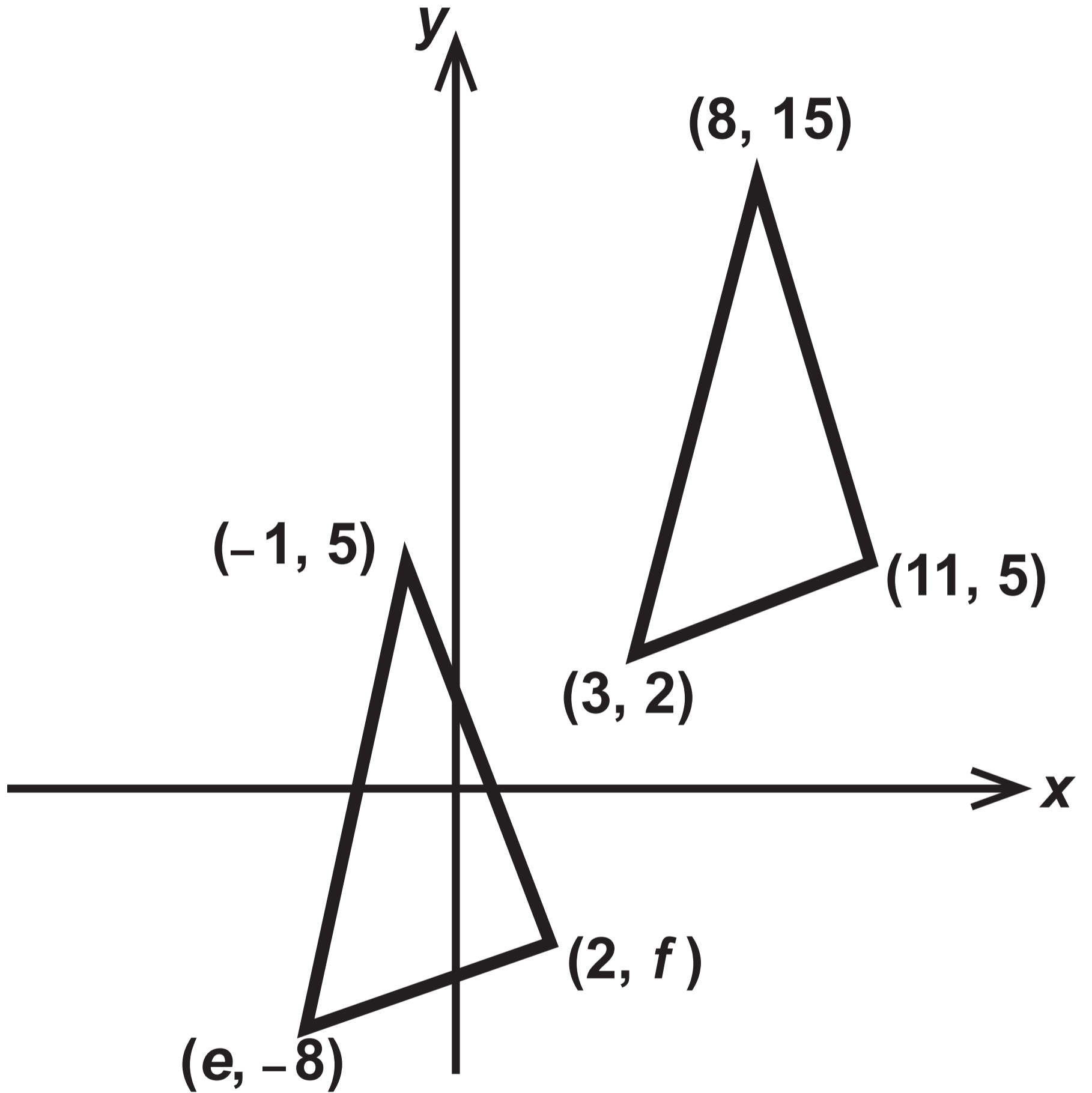

# Question 7 (b)

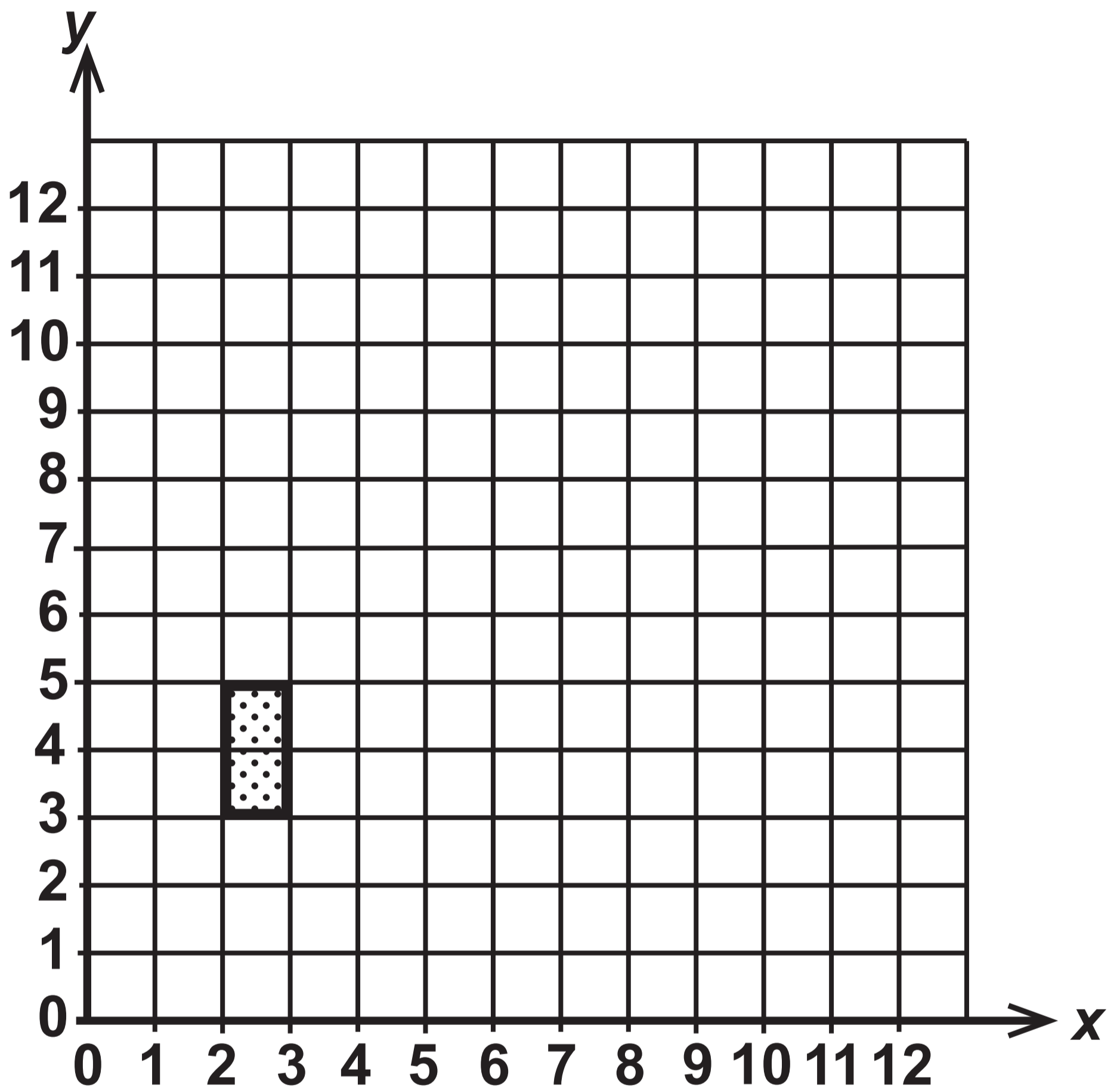

## Question 8

**Alison's cards**

**C A E R N A R F O N**

**Sarfraz's cards**

**A B E R**

## Question 10

Diagram NOT drawn to scale

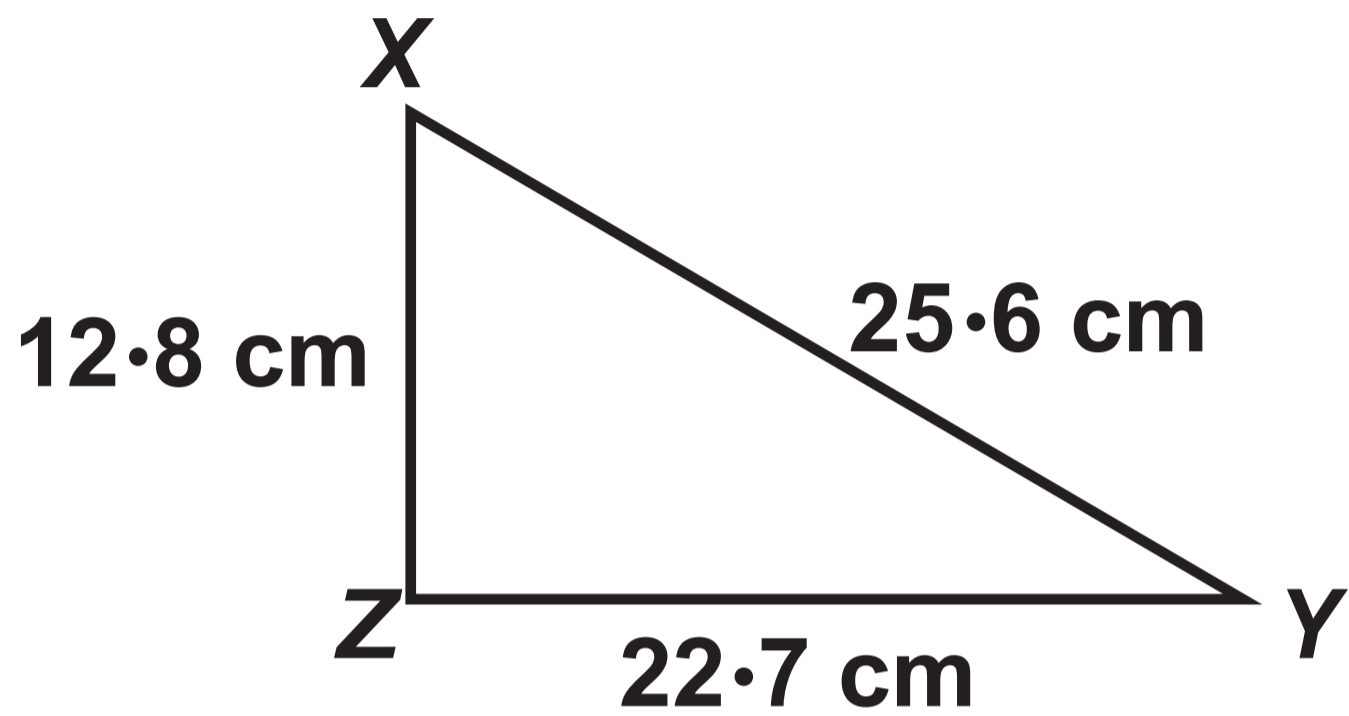

# Question 11 (a)

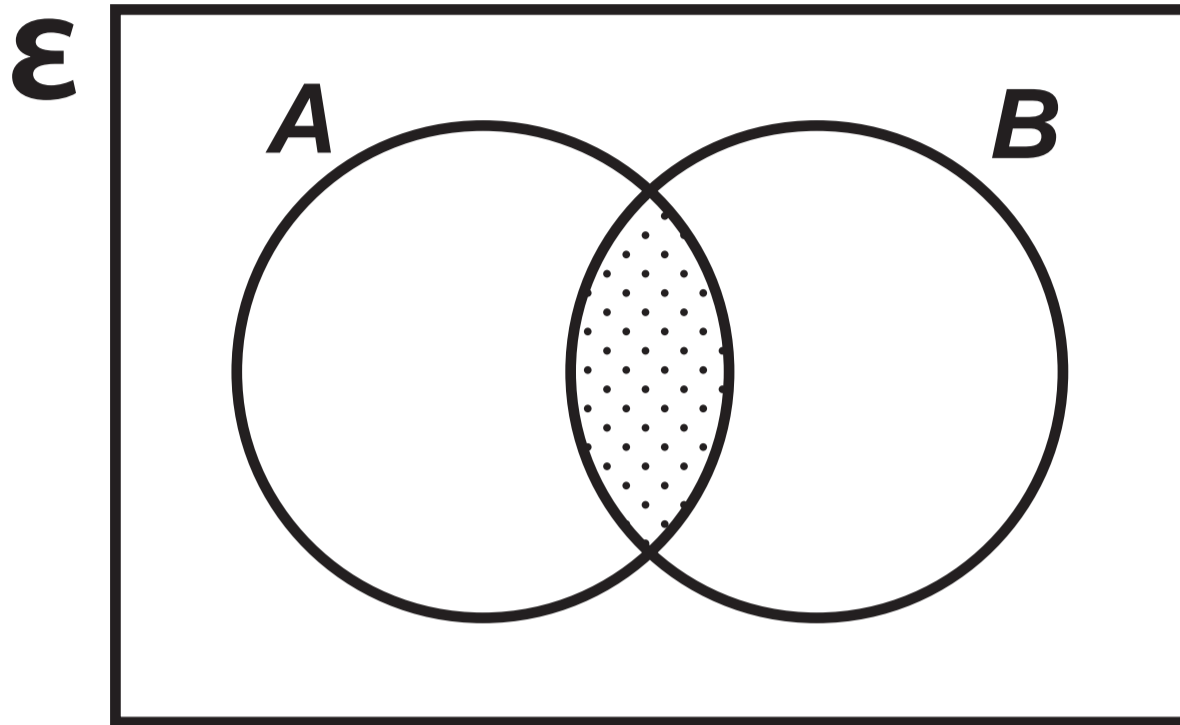

# Question 11 (b)

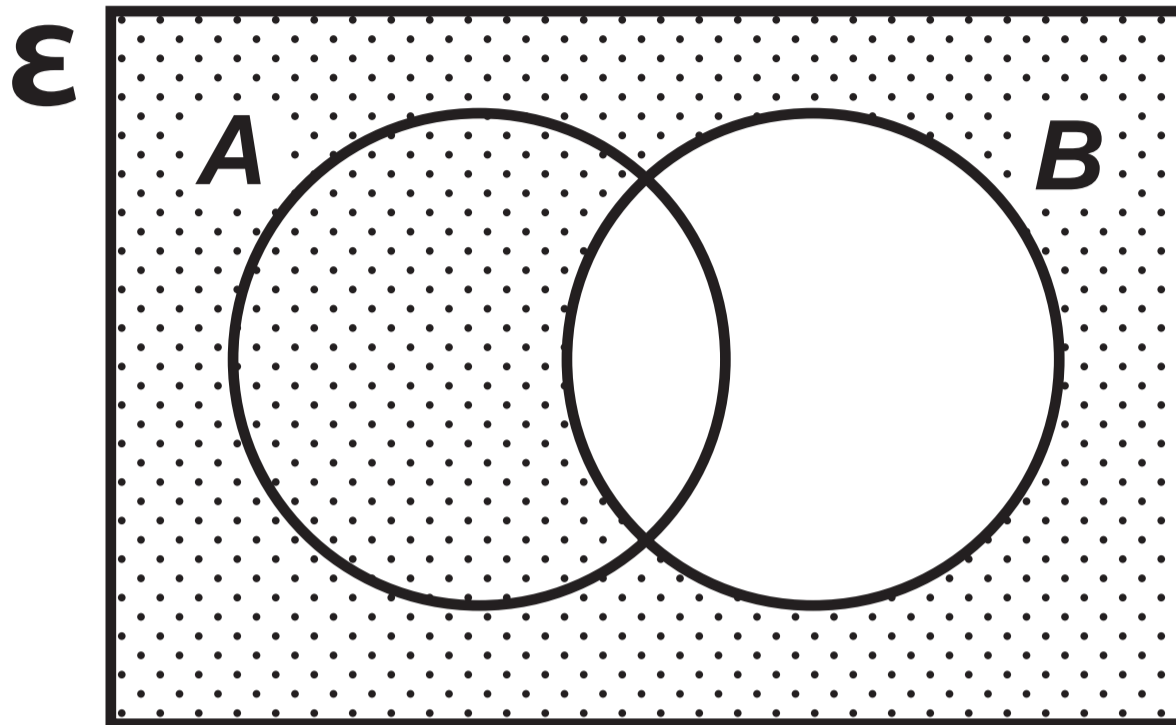

# Question 13

**Pie chart 1**  
**128 female staff**

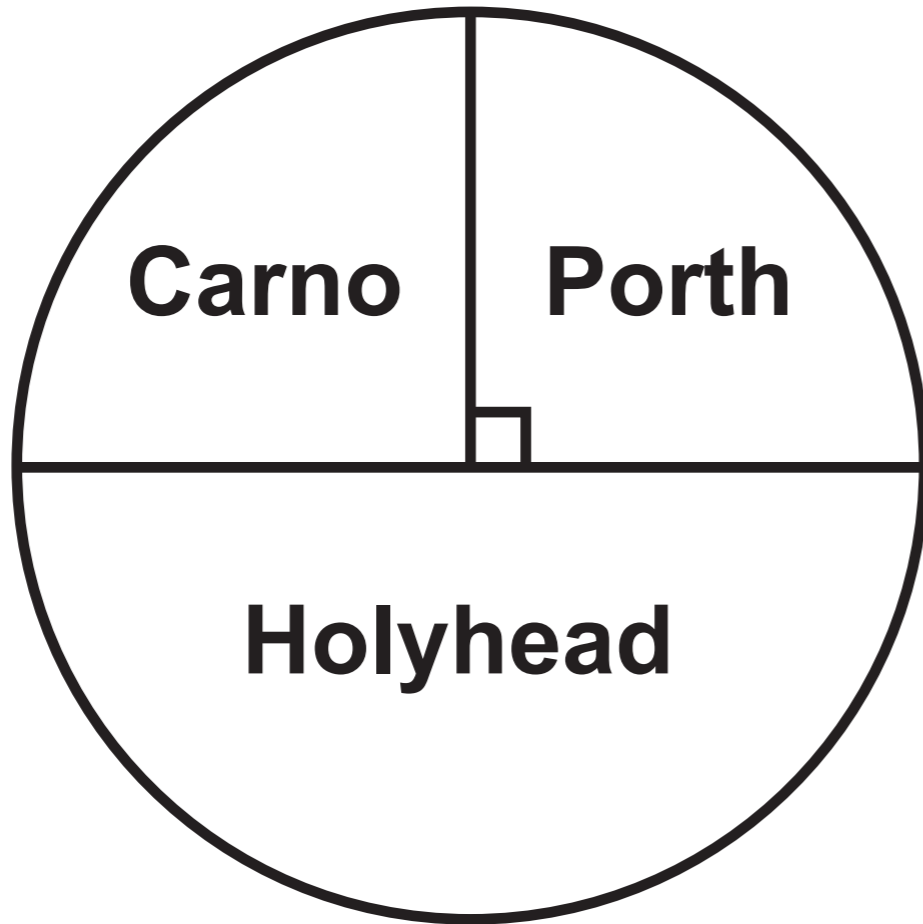

**Pie chart 2**  
**72 male staff**

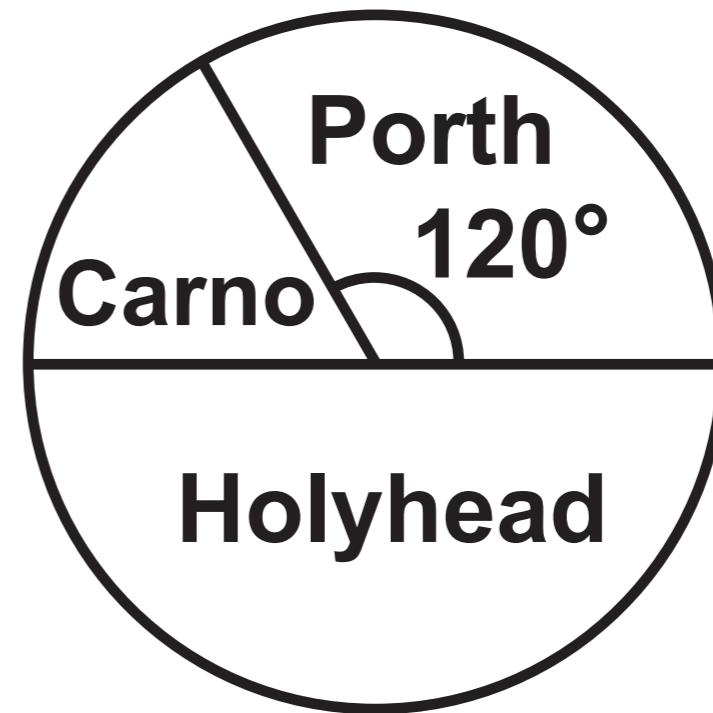

## Question 14

Diagram NOT drawn to scale

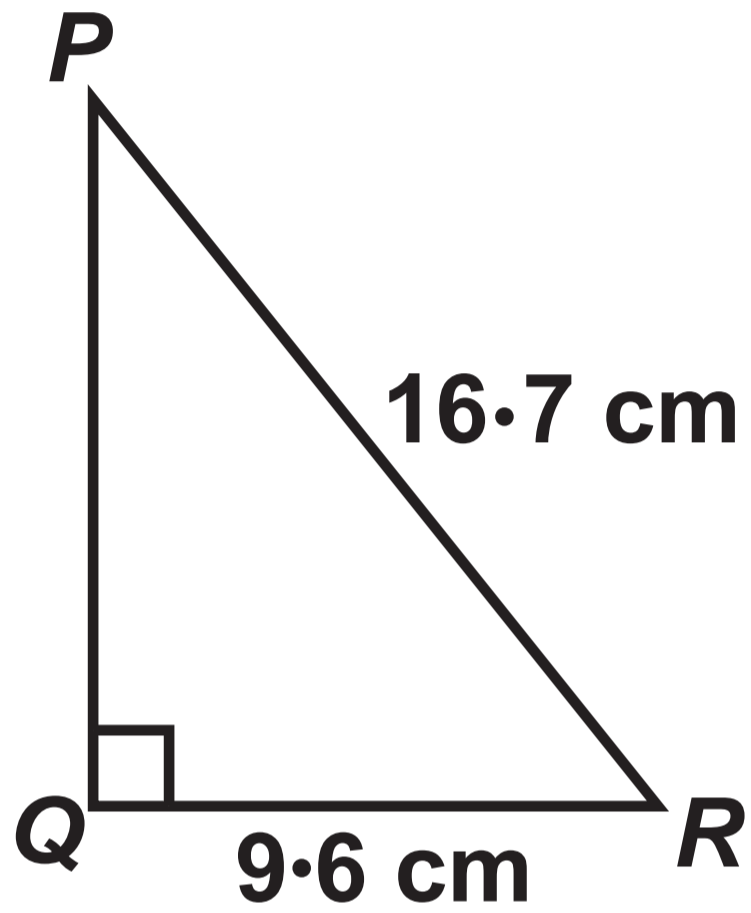

# Question 18

Diagram NOT drawn to scale

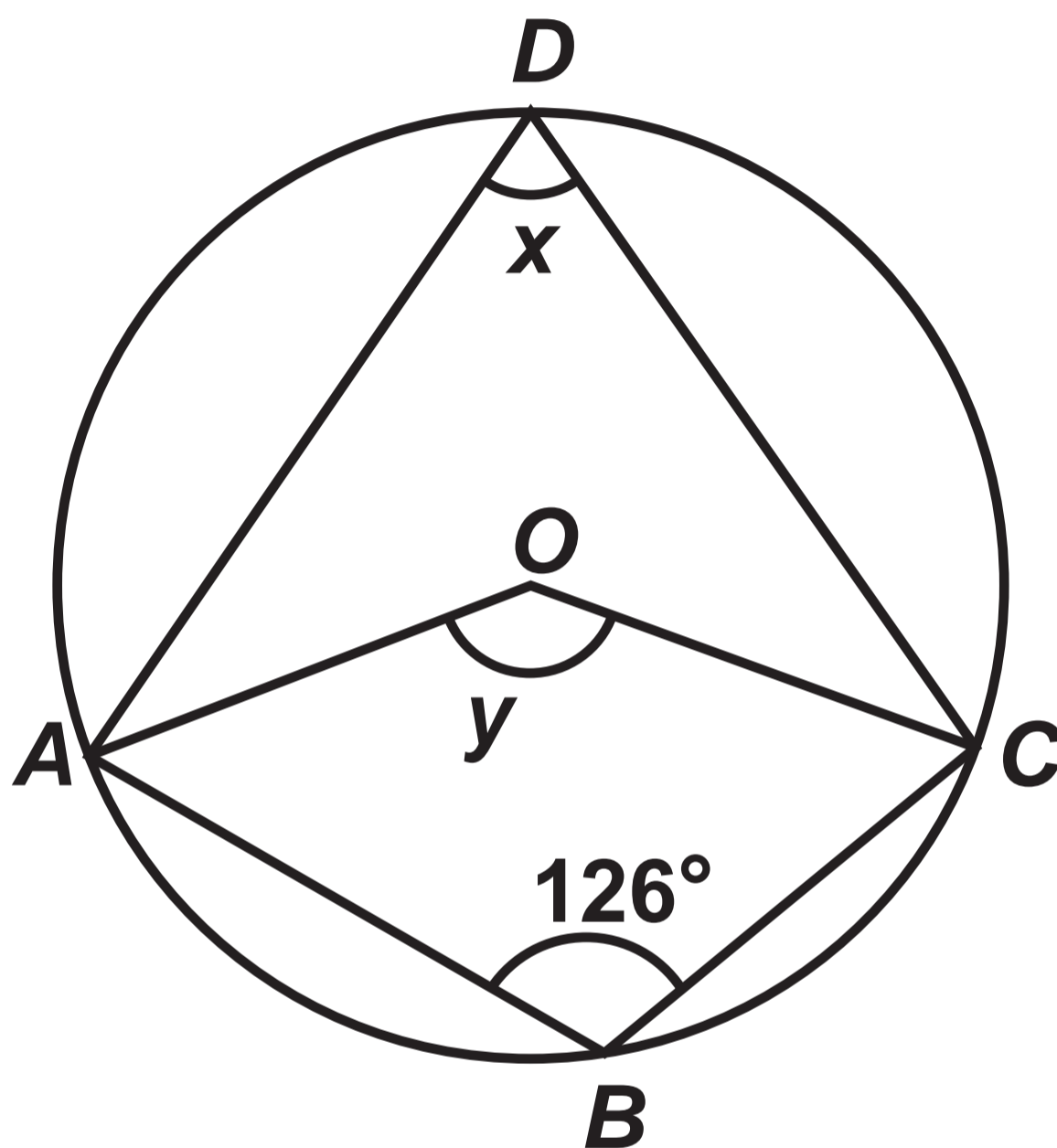

**GCSE  
MATHEMATICS  
and  
NUMERACY**



**FORMULA LIST  
INTERMEDIATE TIER  
GCSE**

**You must not write on these formula pages.**

**Anything you write on these formula pages will gain NO credit.**

## Formula List – Intermediate Tier

Area of trapezium  $= \frac{1}{2} (a + b) h$

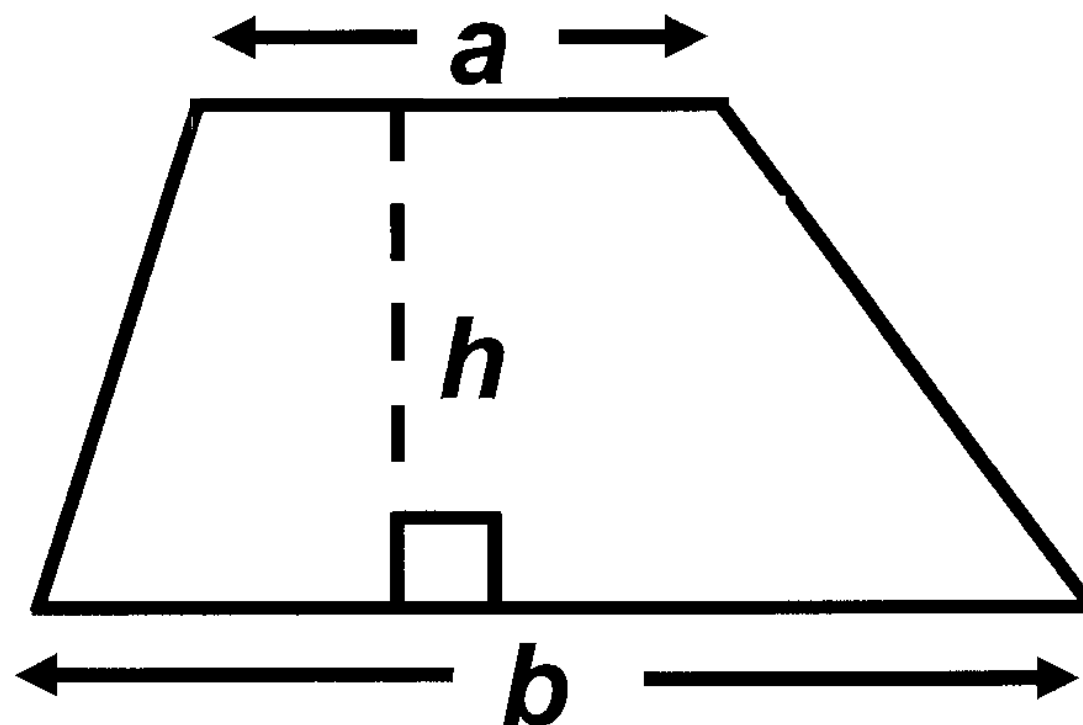

Volume of prism =  
area of cross – section  $\times$  length

