



GCSE

3420U10-1

FRIDAY, 14 JUNE 2019 – MORNING

PHYSICS – Unit 1:

Electricity, Energy and Waves

FOUNDATION TIER

1 hour 45 minutes plus your additional time allowance

Surname

Other Names

Centre Number

Candidate Number

0

ADDITIONAL MATERIALS

In addition to this paper you will require a calculator and a ruler.

INSTRUCTIONS TO CANDIDATES

Use black ink, black ball-point pen or your usual method.

Write your name, centre number and candidate number in the spaces on the previous page.

Answer ALL questions.

Write your answers in the spaces provided in this booklet. If you run out of space use the additional pages at the back of the booklet.

INFORMATION FOR CANDIDATES

The number of marks is given in brackets at the end of each question or part-question.

The assessment of the quality of extended response (QER) will take place in question 3(a).

Answer ALL questions.

1 Three types of wave spread from an earthquake. They are called P waves, S waves and surface waves. The diagram opposite shows waves spreading out from an earthquake at X to monitoring stations A, B and C on the Earth's surface.

(a) State TWO differences between P and S waves. [2]

- 1 (b) Put a tick (✓) in the correct boxes in the following table to show which type of wave is detected at each point. The first row has been completed for you. [3]

Monitoring stations	P wave	S wave	Surface wave
A	✓	✓	✓
B			
C			

5

- 2 A teacher places a wire in a magnetic field. A current is passed through the wire and a force makes it move downwards. The diagram opposite shows how the apparatus was set up to show this effect.
- A current is passed through the wire from W to X. A force makes the wire move **DOWNWARDS**.

(a) Tick (✓) the boxes alongside the **THREE** correct statements below. [3]

The direction of the magnetic field is from N to S in the diagram.

The direction of movement is given by Fleming's right hand rule.

A current from X to W makes the wire move upwards.

When two South poles face each other the wire moves upwards.

A stronger magnetic field makes the wire move upwards.

This effect is used in electric motors.

2 (b) A student suggests to the teacher that the effect could be investigated further. Explain how the teacher could make changes that would affect the SIZE of the force on the wire.

[3]

- 2 (c) In another experiment using the magnets, a single coil of wire WXYZ is placed between the magnets. A current is passed through the coil in the direction shown by the arrow in the diagram opposite.

Draw an arrow on the diagram opposite to show the direction of the current in YZ.

LABEL THE ARROW C. [1]

Draw a second arrow on the diagram to show the direction of the force on YZ.

LABEL THE ARROW F. [1]

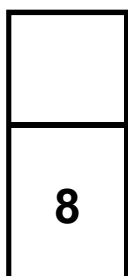

3 (b) The chart opposite shows the number of units of electricity used EACH DAY PER PERSON for the top twelve consuming nations in Europe for the year 2002.

(i) Name ONE country in which people use three times as much electrical energy as in Germany. [1]

(ii) Norway is closer than France to the Earth's North pole. Explain how this may account for the different amounts of electricity consumed in these countries. [2]

3 (b)(iii)

The cost of a unit of electricity in Norway is half of the U.K. cost. Ann suggests that a person's electricity bill in Norway would be half of that paid in the U.K.

Use information in the chart to explain whether you agree with this suggestion. [2]

3 (b)(iv)

In 2002, the average family in the U.K. consisted of three people.

- I. Calculate the number of units used by this family in ONE week. [2]

Units used = _____ kWh

- II. Use an equation from the insert to calculate how much this family would pay for electricity in a week in the U.K. in 2002.

The cost of one unit of electricity = 8 p. [2]

Cost = _____ p

15

4 Some pupils set up the circuit opposite to measure the current in a resistor (R) and the voltage across it. The circuit is used to give a number of readings.

(a)(i) LABEL the parts of the circuit diagram shown opposite. [3]

(ii) State the purpose of the variable resistor. [1]

- 4 (b) The circuit was used to obtain the following results.

Voltage (V)	Current (A)
0.0	0.0
2.0	0.8
4.0	1.6
6.0	2.4
10.0	4.0
12.0	4.8

- (i) Plot the data on the grid opposite and draw a suitable line. [3]
- (ii) Use your graph and the equation:

$$\text{resistance} = \frac{\text{voltage}}{\text{current}}$$

to calculate the resistance of the resistor at 8.0V. [2]

Resistance = _____ Ω

4 (b)(iii)

Complete the following sentence about the trend on the graph by underlining the correct word or phrase in each bracket. [3]

As the voltage increases, the current

(DECREASES / STAYS THE SAME / INCREASES)

at a (DECREASING / CONSTANT / INCREASING)

rate. As a result, the resistance

(DECREASES / STAYS CONSTANT / INCREASES).

4 (b)(iv)

One pupil in the group, Billy, made the statement that the power of the resistor increases as the voltage increases. By using an equation from the insert, explain whether you agree with Billy. [2]

(v) A second group of pupils use a resistor that has HALF the resistance of the one in this experiment.

DRAW A LINE ON THE ORIGINAL GRID opposite page 14 to show how the current through it would change with voltage. [2]

5 Satellites can be positioned in orbit to communicate with base stations on the ground. Messages can be relayed around the world in this way. The diagram opposite shows base stations A, B, C and D and four satellites.

(a) The diagram shows the path of a signal sent from base station A to base station B.

CONTINUE THE PATH OF THE SIGNAL so that it can be received at base station C. [1]

(b) The distance from a base station to a satellite is 36 000 km. Calculate the total distance travelled by the signal in going from A to C.

Give your answer in METRES. [3]

Total distance = _____ m

- 5 (c) The time taken for the signal to travel from A to C is 0.48 s. Use an equation from the insert to calculate the speed of the signal. [2]

Speed = _____ m/s

6

- 6 In a class experiment, the volumes of two different masses of trapped air (A and B) were measured as their temperature was increased from 0°C to 60°C . The results are shown in the graphs opposite.

- (a)(i) At what temperature is the volume of gas B equal to 22.0 cm^3 ? [1]

Temperature = _____ $^{\circ}\text{C}$

- (ii) The difference in the volumes of the two gases at 0°C is 4.2 cm^3 . Use the graph to calculate the difference in their volumes at 60°C . [1]

Difference in volumes = _____ cm^3

- (iii) Both graph lines are straight. Using your answer to (ii) above, compare their gradients. [1]

6 (b)(i)

If both lines are extended to lower temperatures, they would meet at -273°C . This temperature is zero on the Kelvin scale of temperature. State the name given to this temperature. [1]

(ii) Calculate the highest temperature **ON THE KELVIN SCALE** reached by the gases in this experiment.

[1]

Temperature = _____ K

(c) In another experiment, gas **B** is kept in a container of fixed volume. State what happens, if anything, to the pressure of the gas as its temperature is increased. [1]

6 (d)(i)

A gas exerts a force of 180 000 N on the walls of its container. The surface area of the container is 1.5 m².

Use an equation from the insert to calculate the pressure of the gas. [2]

Pressure = _____ Pa

6 (d)(ii)

The gas is kept in a container at constant pressure. Julia says that if the area is doubled, the force would halve. Explain whether Julia's statement is correct.

[2]

10

- 7 The Welsh Government Warm Homes Scheme, called Nest, aims to make Welsh homes warmer and more energy efficient places to live. Nest is accessible to all homeowners in Wales and provides advice on saving energy.**
- (a) Draughts, floors, windows, walls and the roof are the five ways energy is lost from a heated house. The pie chart opposite shows the percentages of energy loss by each of the five ways.**

Use the information below to COMPLETE THE LABELLING on the pie chart. [3]

One label has been completed already.

- The percentage energy loss through the walls is greatest.**
- Windows and draughts have equal percentage energy losses.**
- Windows and floor percentage losses add up to equal the percentage loss through the roof.**

7 (b) To reduce energy loss through the roof the Nest Scheme suggests the installation of fibre-glass insulation in the loft.

(i) Explain how fibre-glass reduces energy loss in the loft by convection. [2]

7 (b)(ii)

There are strict regulations about the minimum thickness of insulation that must be installed in the loft of a new house. The graph opposite shows how the required thickness of loft insulation has changed since 1960.

Use information from the graph to tick (✓) the **THREE** correct statements. [3]

Every five years the required thickness of loft insulation increases.

The required thickness of loft insulation in 2000 is 8 times thicker than in 1970.

In 1960 houses did not lose any energy through their roof.

A house built in 1980 needs 210 mm of loft insulation added to bring it up to 2015 standards.

The **GENERAL** trend of the graph indicates that the required thickness of loft insulation has increased at an increasing rate.

continued on the following page

The required thickness of loft insulation will remain constant after 2015.

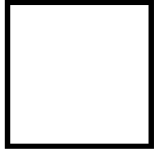

7 (b)(iii)

A homeowner must install loft insulation in a new extension. IT HAS A LOFT AREA OF 120 m^2 .

The insulation must be at least 270 mm thick to meet building regulations.

There is a selection of fibre-glass insulations available.

Study the table opposite.

Calculate the payback time if INSULATION 3 was installed in the 120 m^2 extension. [2]

Payback time = _____ years

7 (b)(iv)

The homeowner considers installing INSULATION 1 as it is cheapest but the builder says that INSULATION 2 should be installed as it will save more money over 40 years.

Explain, with calculations, whether the builder is correct. [2]

12

8 In class, a teacher demonstrates refraction using a ripple tank. The diagram opposite shows plane wavefronts travelling across a boundary between shallow and deep water. The frequency of the waves remains **CONSTANT** during refraction.

- (a) Using a ruler, students measure the distance between wavefronts **A** and **B**. This measurement is the wavelength of the water waves in deep water. The distance between wavefronts **C** and **D** is measured to obtain their wavelength in the shallow water. The results are shown below.

	Deep water (AB)	Shallow water (CD)
Wavelength (mm)	10	5

- (i) State how the measurement of wavelength could be improved. [1]

8 (a)(ii)

The wavelength in the deep water is twice the wavelength in the shallow water.

The teacher suggests, “the speed of the wavefronts in shallow water is double the speed of the wavefronts in the deep water.” Using information provided explain if the suggestion made by the teacher is correct. [2]

8 (b) An endoscope uses optical fibres. It can be used by doctors to produce medical images of a specific area inside a patient. A bundle of fibres is inserted into the body. Some of the fibres carry light into the body and others return the light reflected off internal surfaces.

The diagram opposite shows a ray of light passing through part of an optical fibre of an endoscope.

(i) State the name given to the change in direction of the signal at S. [1]

(ii) State the TWO conditions needed for the ray of light to change direction at S. [2]

8 (b)(iii)

Medical images can also be obtained from a computer tomography (CT) scan. This type of scan uses X-rays targeted at the patient from different positions outside the body. The information collected is processed by a computer to produce detailed 3D image segments of the patient.

Explain a disadvantage of using a CT scan to obtain medical information compared to using an endoscope. [2]

8

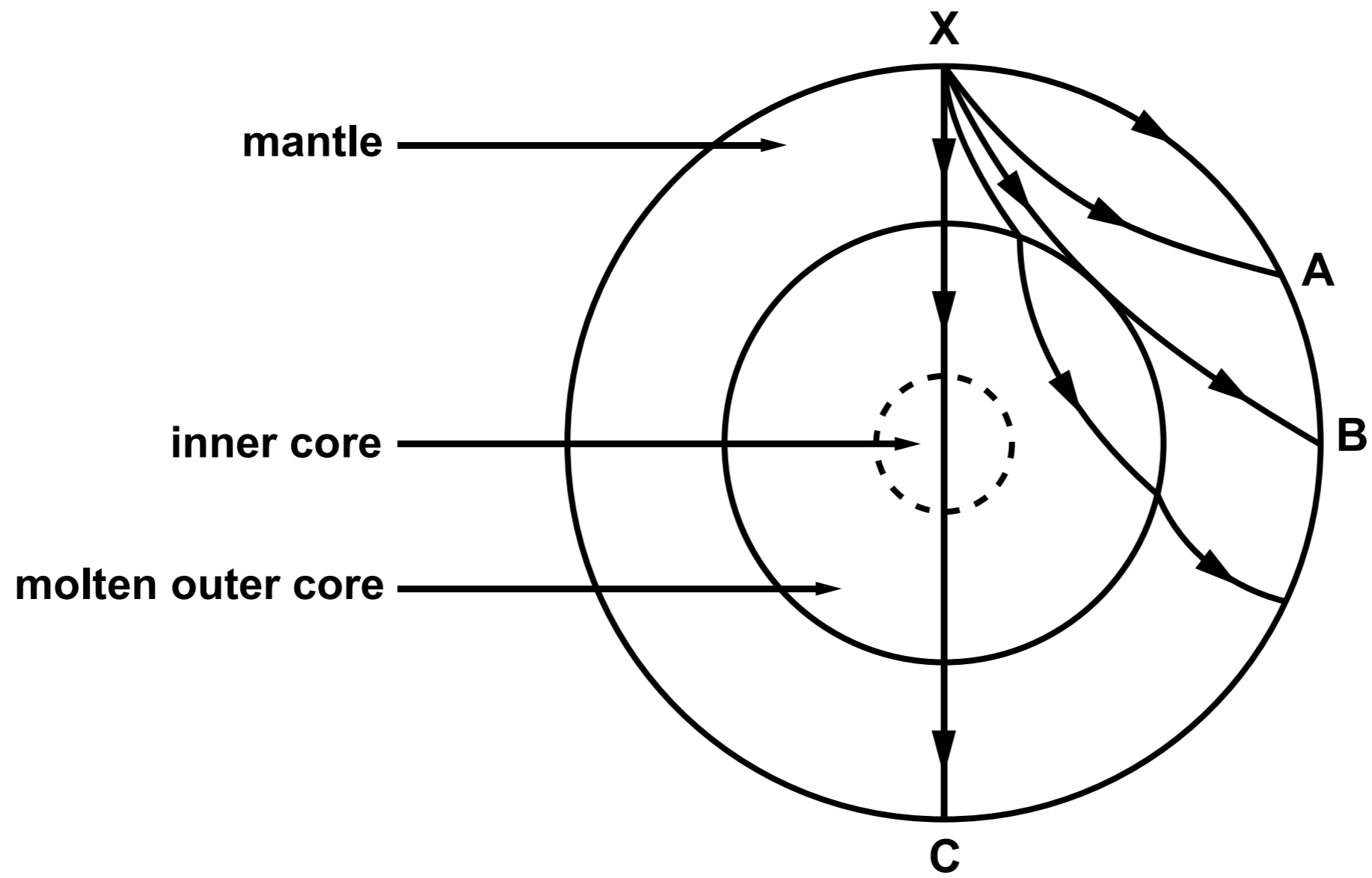

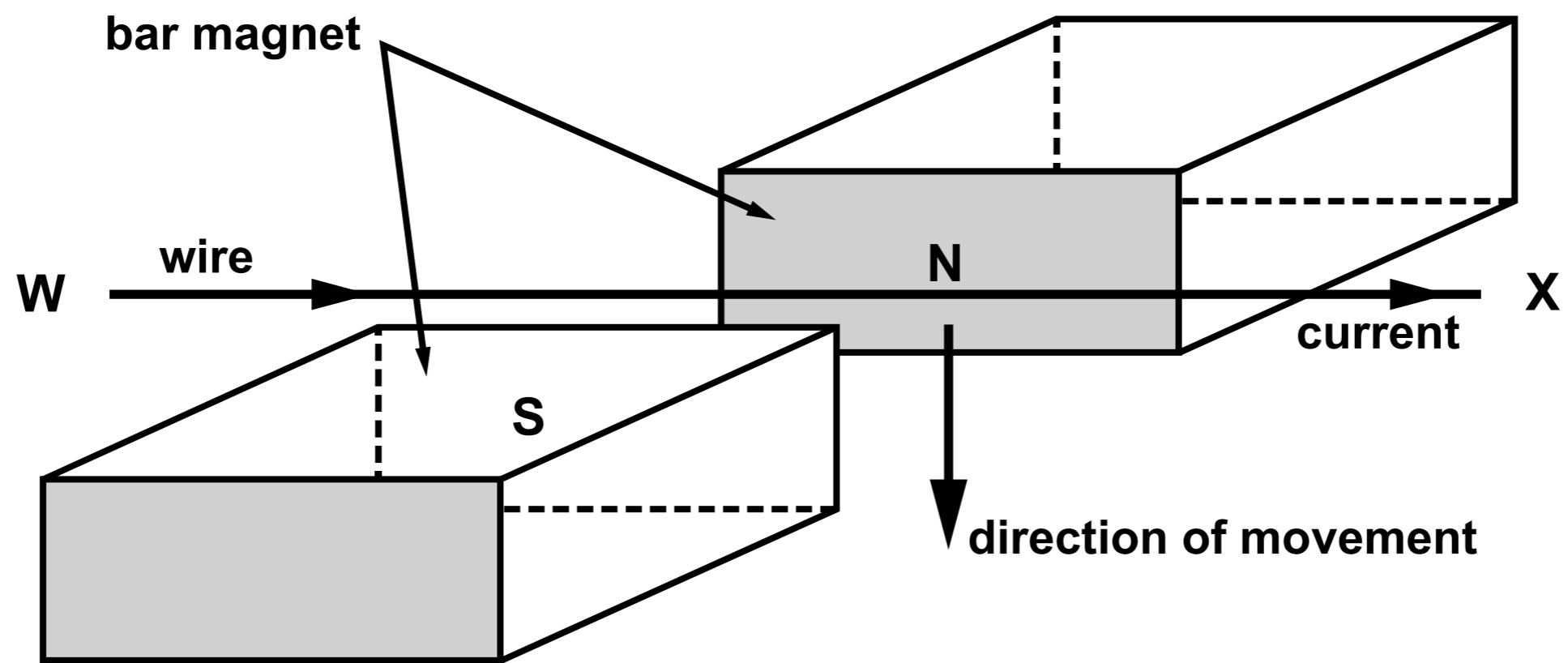

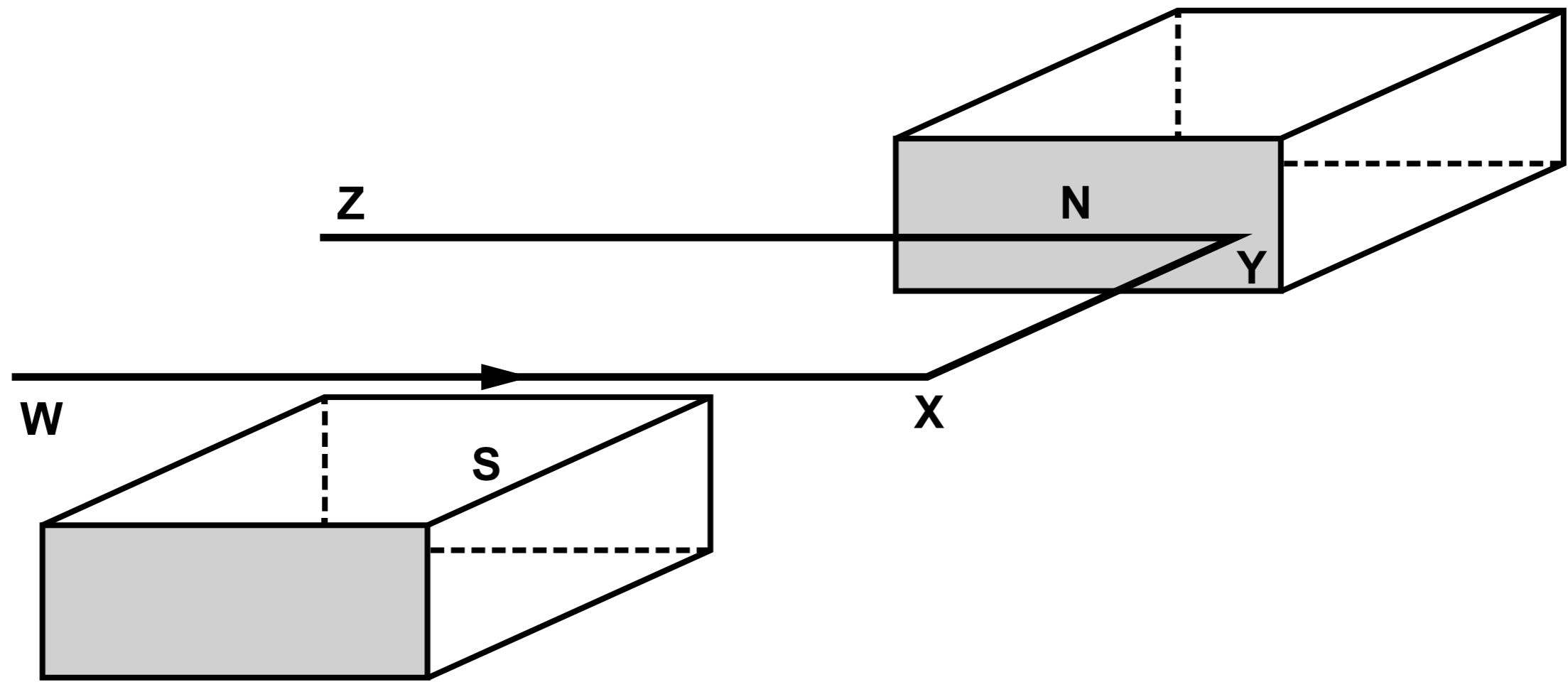

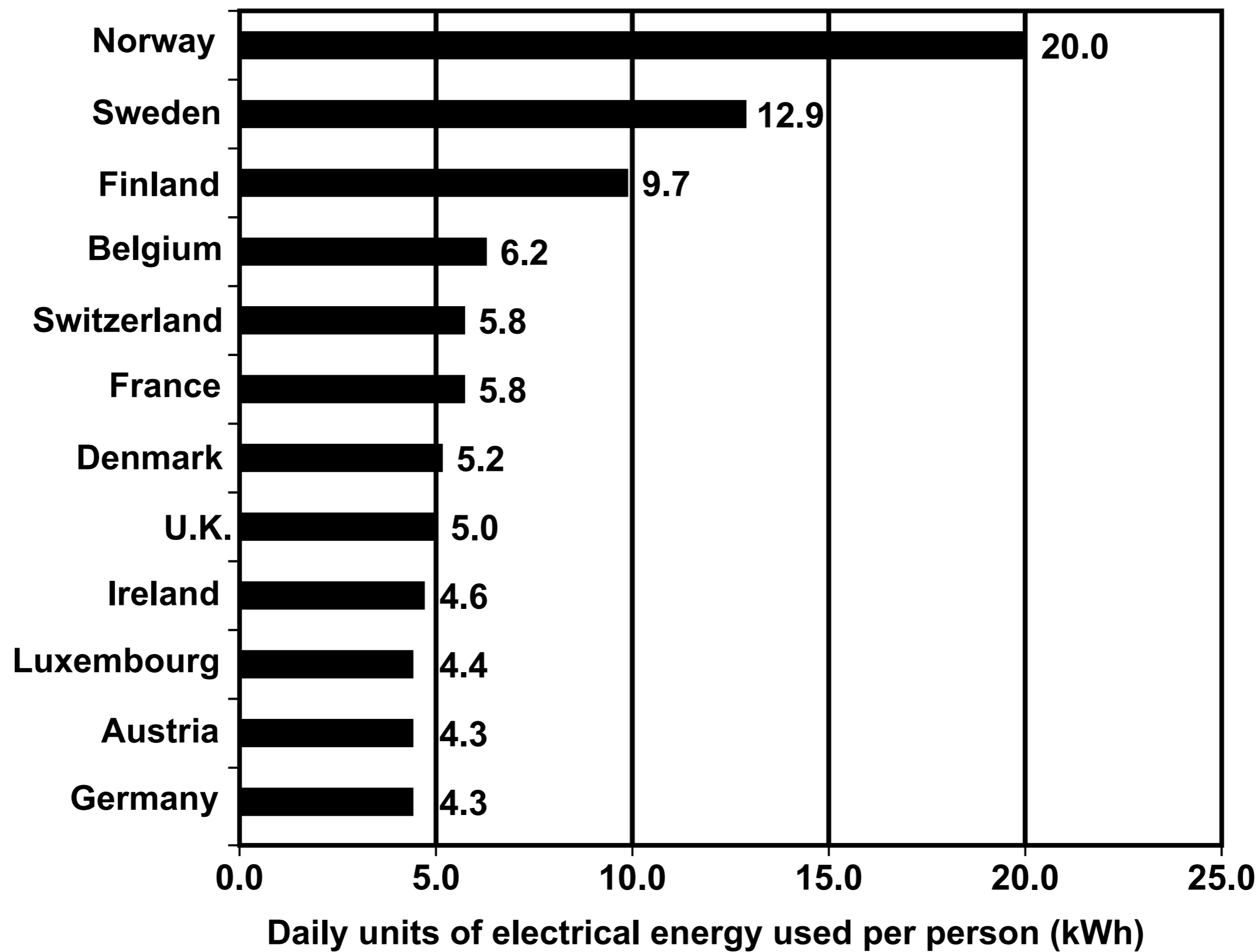

Source "Energy Powering Your World" EFDA - European Fusion Development Agreement (2002)

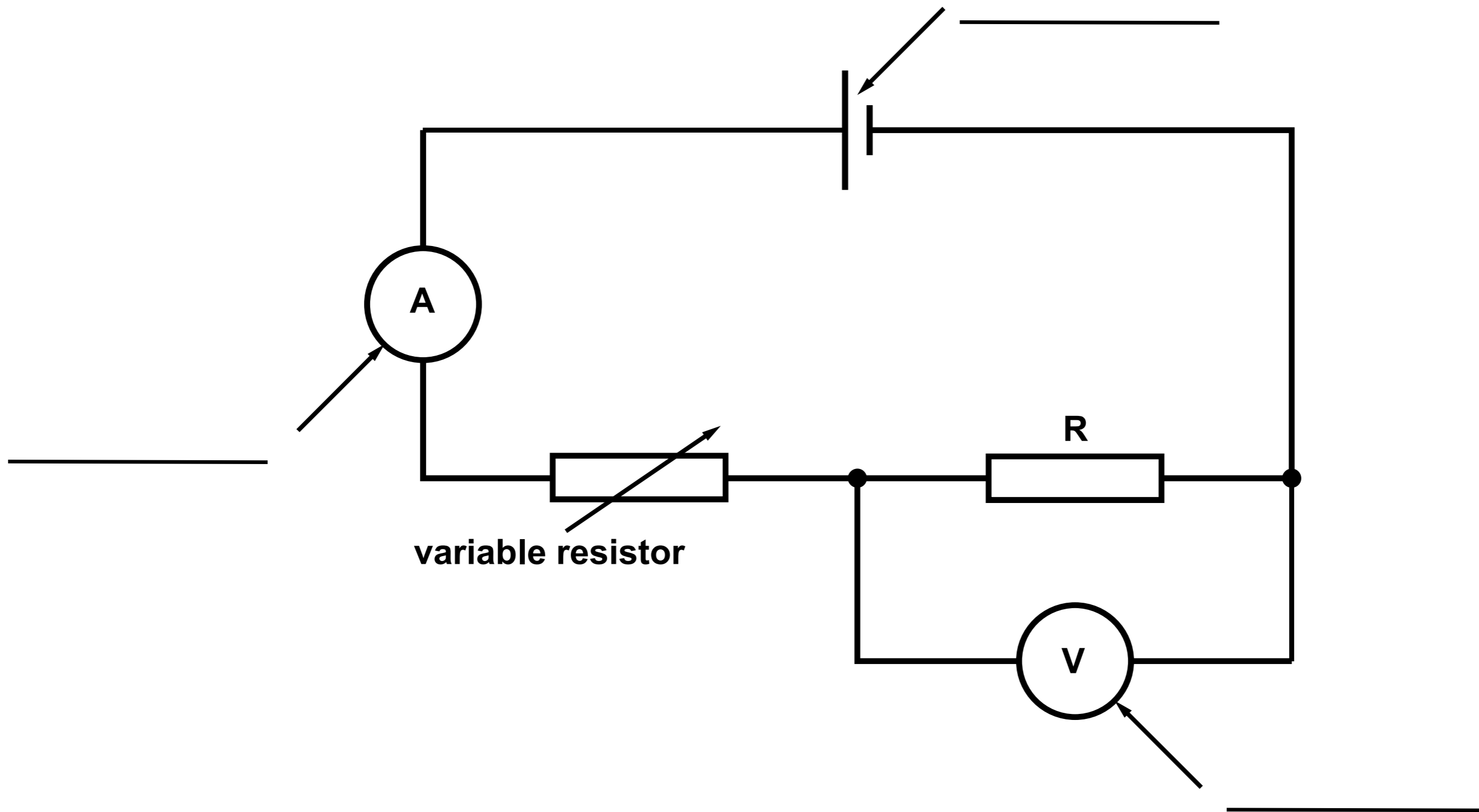

Current (A)

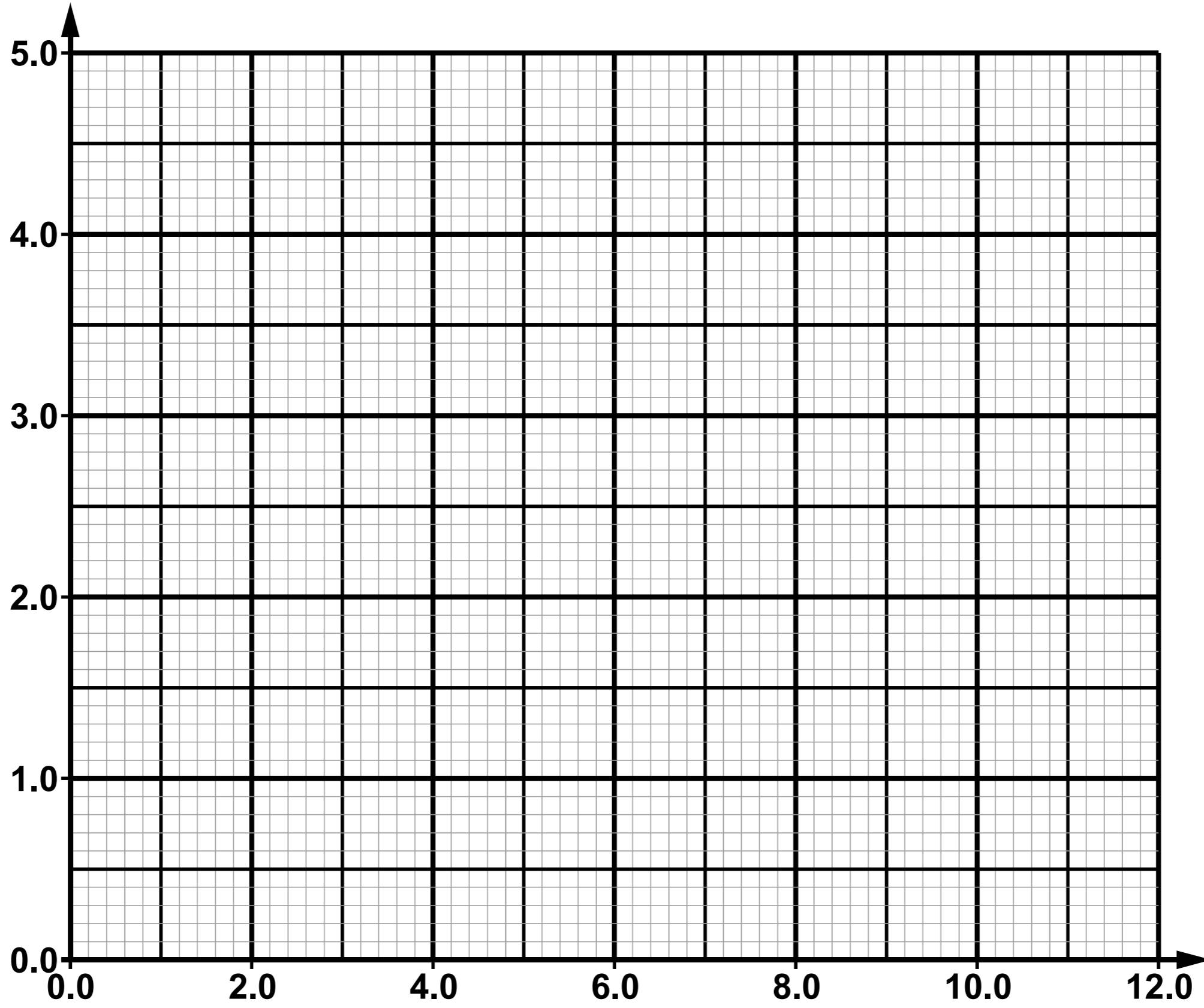

Voltage (V)

Diagram is not drawn to scale

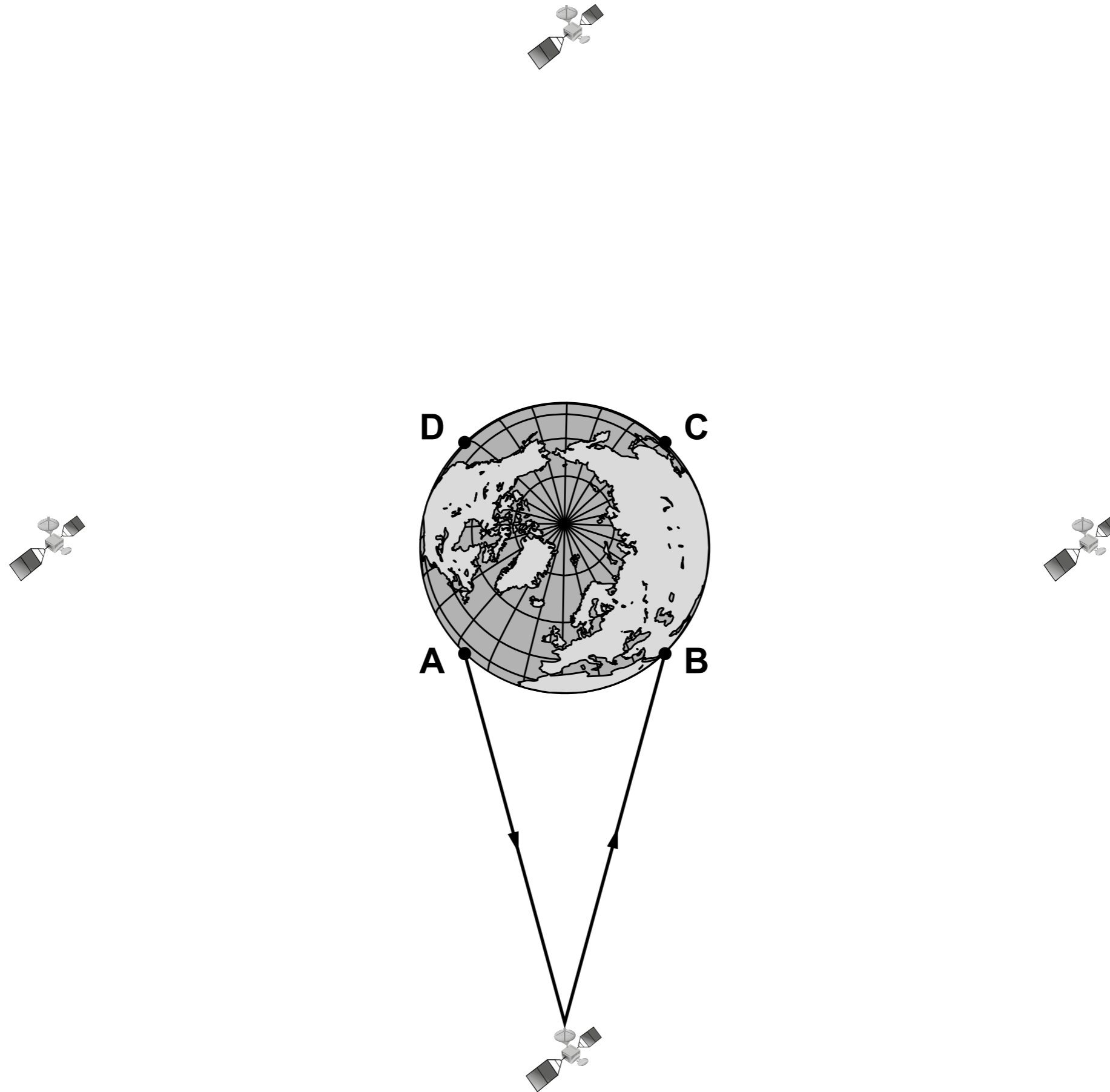

Volume (cm³)

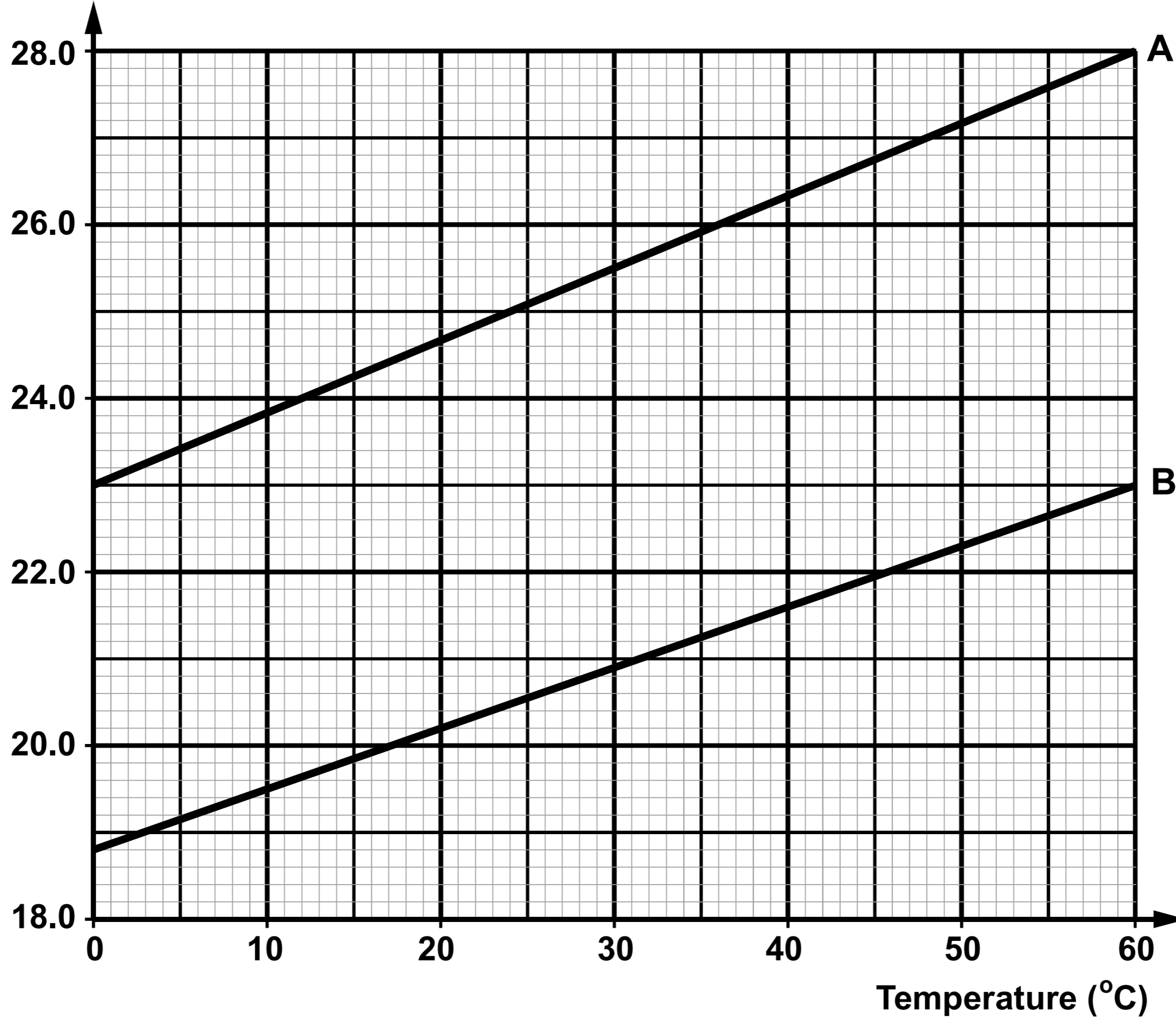

A

B

Temperature (°C)

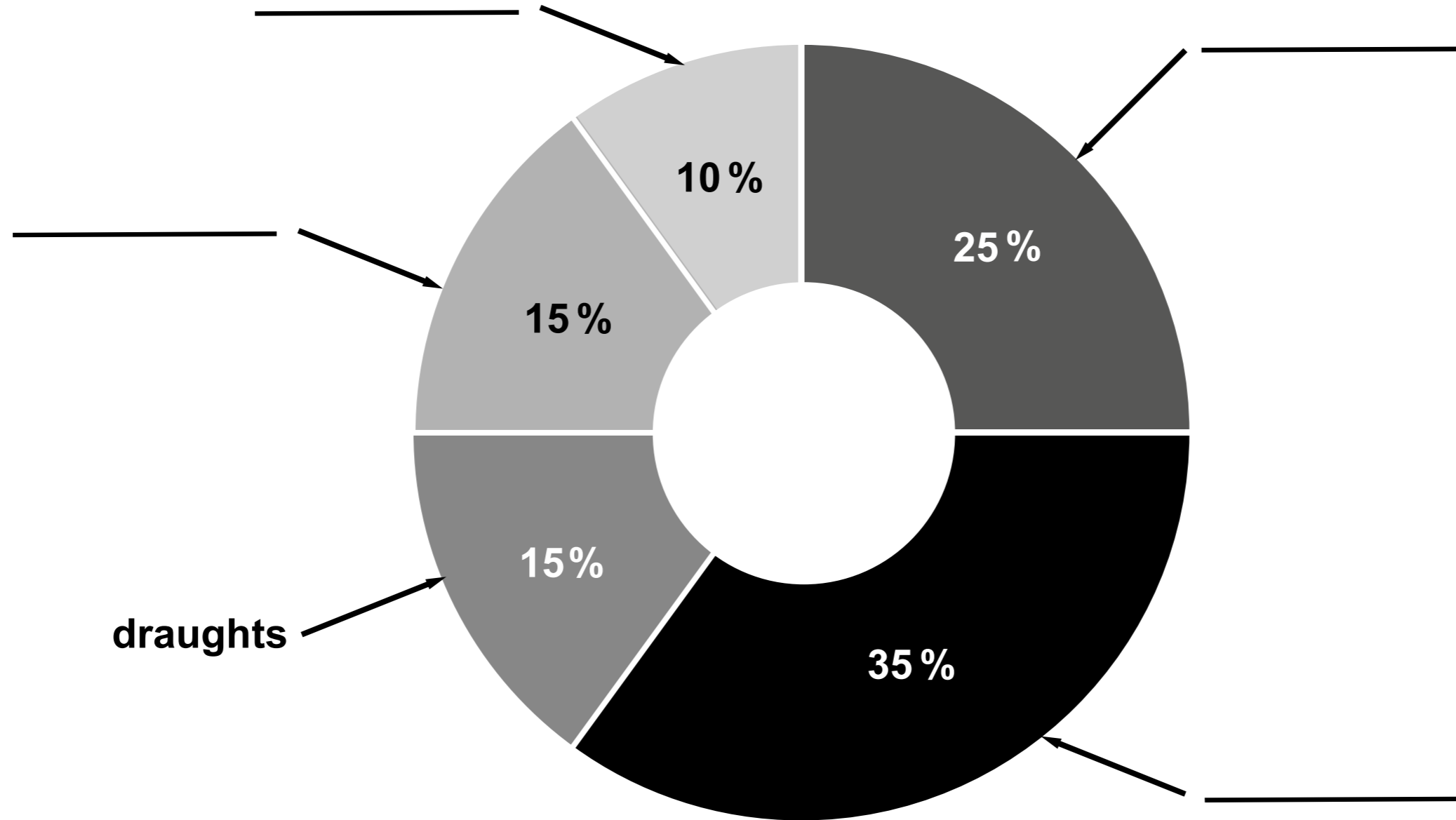

**Required thickness of
loft insulation (mm)**

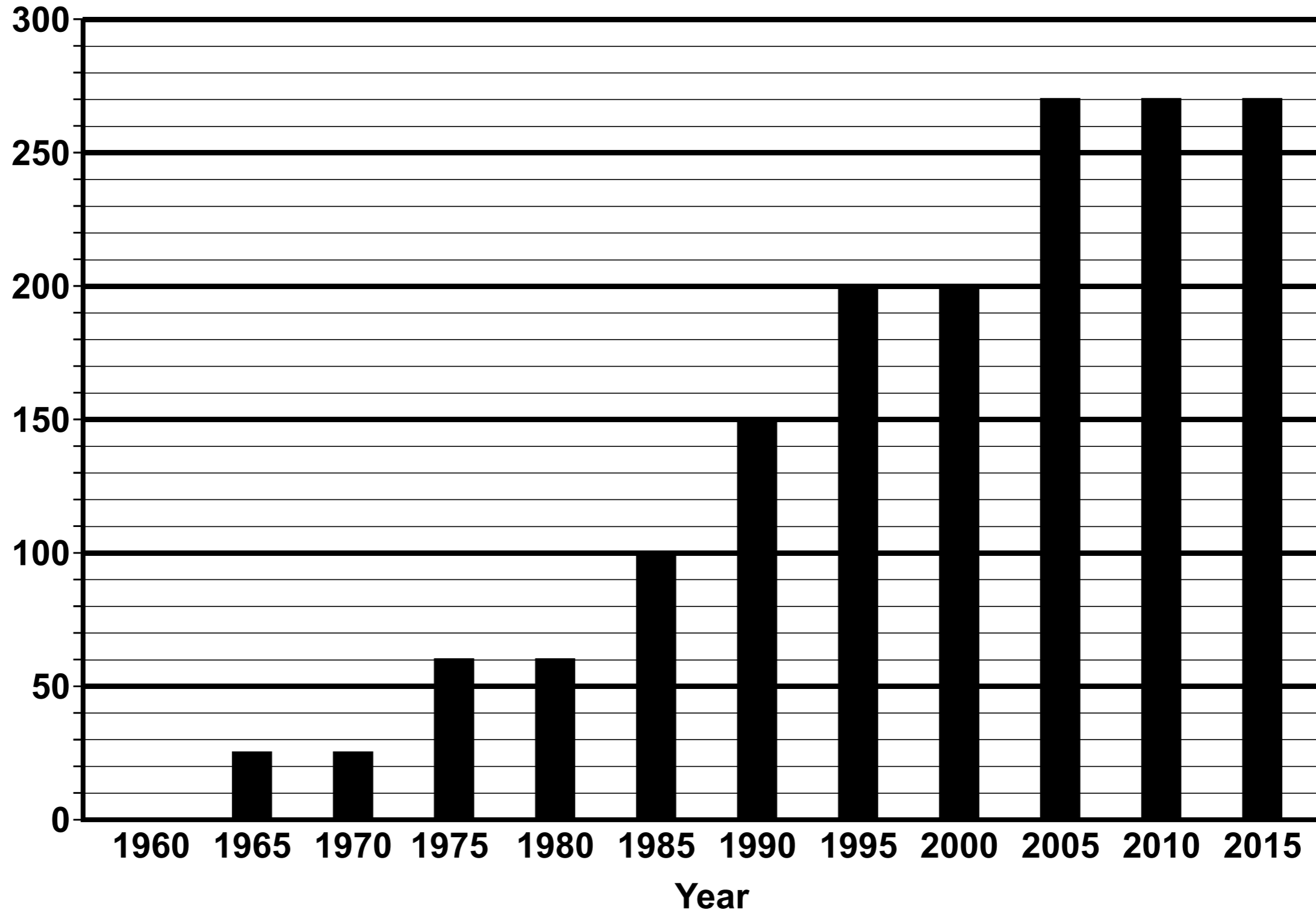

	Insulation 1 (270 mm thick)	Insulation 2 (350 mm thick)	Insulation 3 (300 mm thick)
Installation cost (£/m²)	3.50	5.55	4.50
Estimated saving per year (£)	84	111	98
Payback time (years)	5.0	6.0	

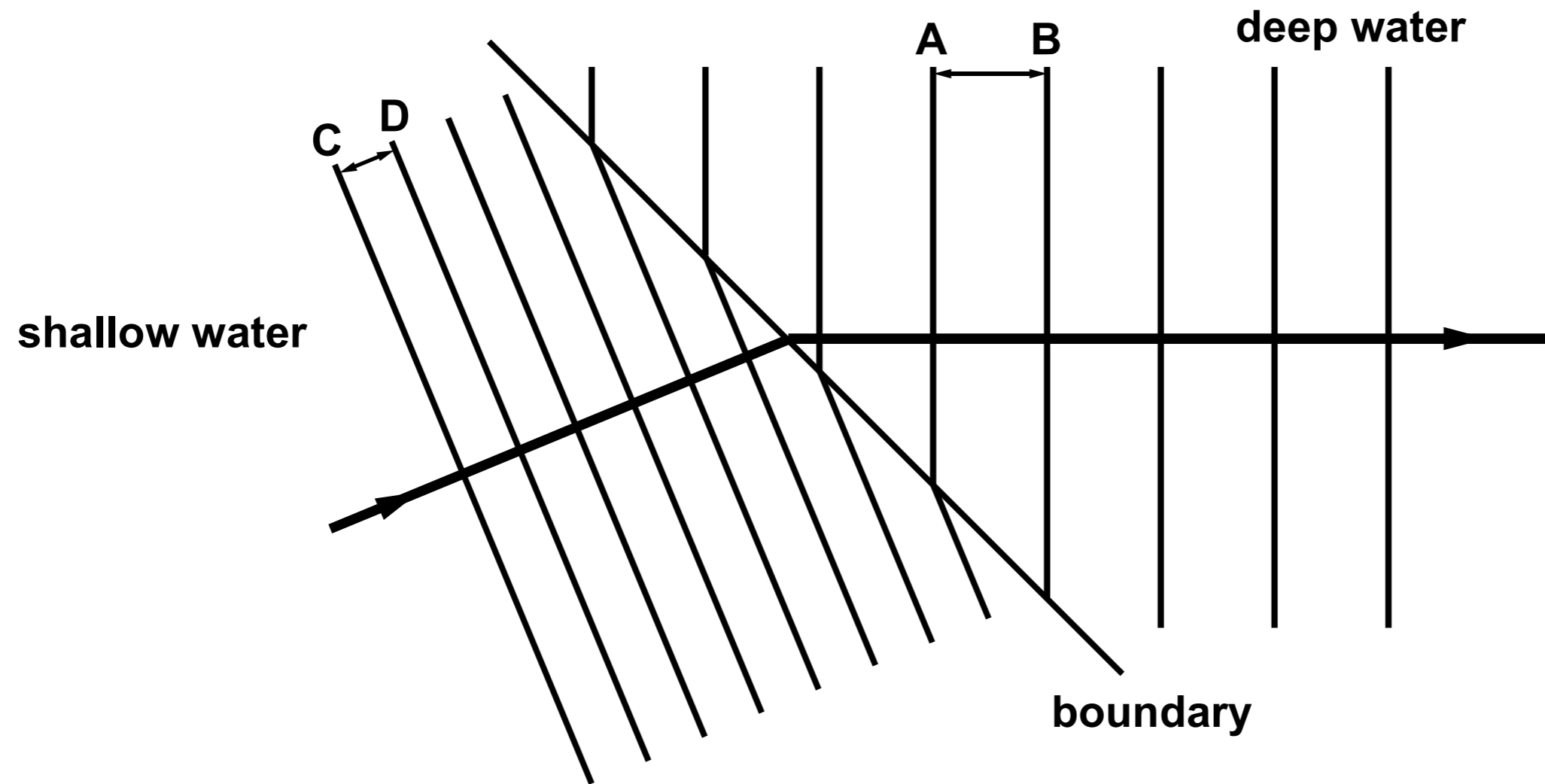

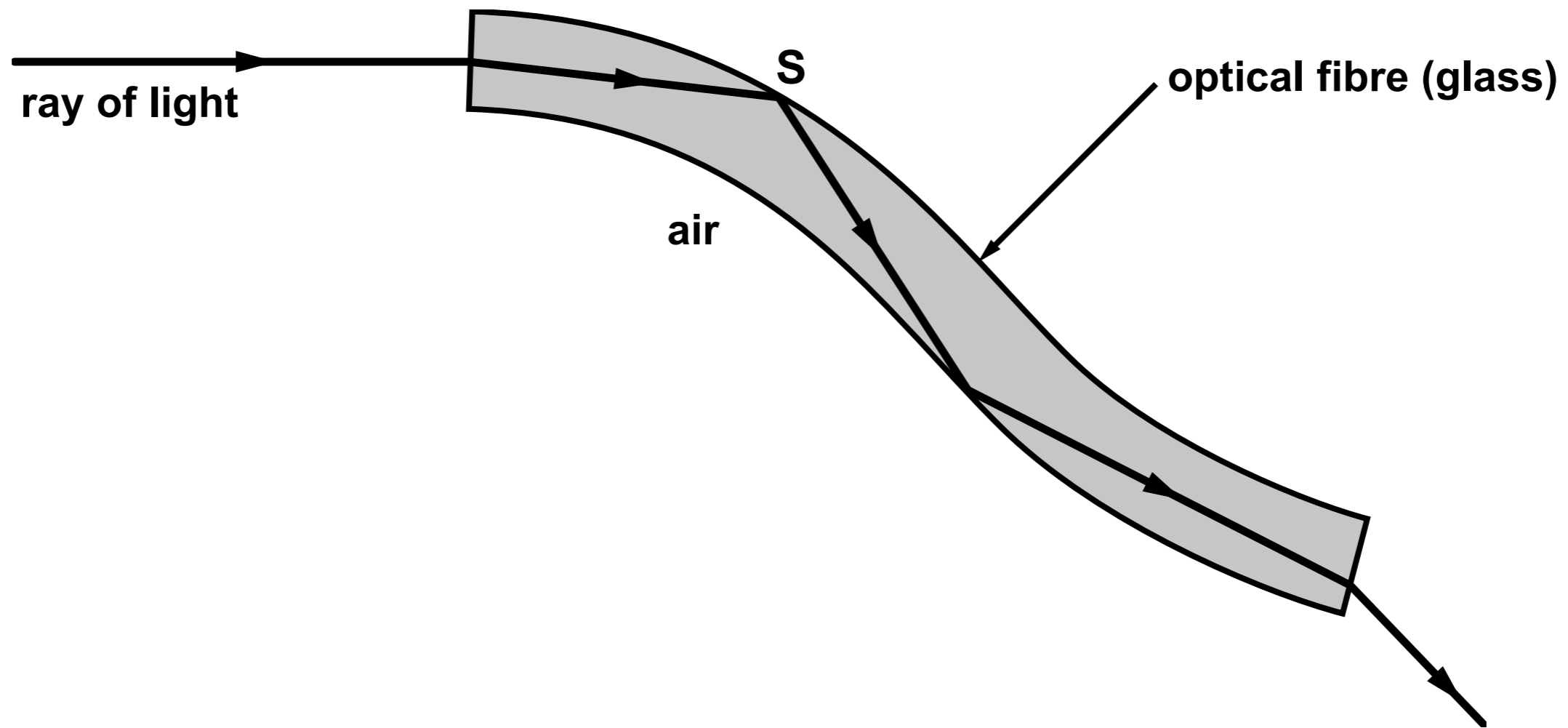



GCSE

3420U10-1

FRIDAY, 14 JUNE 2019 – MORNING

PHYSICS – Unit 1:

Electricity, Energy and Waves

FOUNDATION TIER

INSERT

EQUATIONS

current = $\frac{\text{voltage}}{\text{resistance}}$	$I = \frac{V}{R}$
total resistance in a series circuit	$R = R_1 + R_2$
energy transferred = power x time	$E = Pt$
power = voltage x current	$P = VI$
% efficiency = $\frac{\text{energy [or power] usefully transferred}}{\text{total energy [or power] supplied}} \times 100$	
density = $\frac{\text{mass}}{\text{volume}}$	$\rho = \frac{m}{V}$
units used (kWh) = power (kW) x time (h) cost = units used x cost per unit	
wave speed = wavelength x frequency	$v = \lambda f$
speed = $\frac{\text{distance}}{\text{time}}$	
pressure = $\frac{\text{force}}{\text{area}}$	$p = \frac{F}{A}$
change in thermal energy = mass x specific heat capacity x change in temperature	$\Delta Q = mc\Delta\theta$
thermal energy for a change of state = mass x specific latent heat	$Q = mL$
V_1 = voltage across the primary coil V_2 = voltage across the secondary coil N_1 = number of turns on the primary coil N_2 = number of turns on the secondary coil	$\frac{V_1}{V_2} = \frac{N_1}{N_2}$

SI MULTIPLIERS

Prefix	Multiplier
m	1×10^{-3}
k	1×10^3
M	1×10^6