



GCSE

**3420U20-1 PHYSICS - Unit 2:
Forces, Space and Radioactivity
FOUNDATION TIER**

**WEDNESDAY, 22 May 2019 –
AFTERNOON**

**1 hour 45 minutes plus your additional
time allowance**

Surname

Other Names

Centre Number

Candidate Number

0

ADDITIONAL MATERIALS

In addition to this paper you will require a calculator and a ruler.

INSTRUCTIONS TO CANDIDATES

Use black ink, black ball-point pen or your usual method.

Write your name, centre number and candidate number in the spaces on the previous page.

Answer ALL questions.

Write your answers in the spaces provided in this booklet. If you run out of space use the additional pages at the back of the booklet.

INFORMATION FOR ³CANDIDATES

The number of marks is given in brackets at the end of each question or part-question.

The assessment of the quality of extended response (QER) will take place in question 7(b).

Answer ALL questions.

1 Absorption spectra can be used to provide information about stars and galaxies.

The diagram opposite shows a simplified absorption spectrum from our Sun.

(a) Place a tick (✓) in the box next to the three correct statements below and on the following page. [3]

The dark lines in the spectra from distant galaxies are blue shifted.

The further away a galaxy is the longer the wavelength of the dark lines.

5

The dark lines in the spectra from distant galaxies are green shifted.

The dark lines can be used to identify the elements present in the star / galaxy.

The dark lines in the spectra from distant galaxies are red shifted.

The further away a galaxy is the shorter the wavelength of the dark lines.

1 (b) The shift of the absorption lines in spectra from distant galaxies provides evidence for the Big Bang model of the creation of the Universe.

State another piece of evidence supporting the Big Bang. [1]

4

7

2 A car is travelling at 10 m/s along a flat road. A driving force of 50 000 N acts on the car for a distance of 20 m causing it to accelerate.

(a)(i) Use an equation from the insert to calculate the work done by the 50 000 N force. [2]

Work done = _____ J

2 (a)(ii)

The car gains 600 000 J of kinetic energy as it accelerates. Calculate how much energy is transferred in other ways. [1]

Energy transfer = _____ J

2 (b) State TWO ways that the DESIGN of the car could be changed to improve its efficiency. [2]

1. _____

2. _____

5

3 Study the diagram opposite.

An ice skater of mass 50 kg and travelling with a velocity of 5 m/s to the right collides with a skater of mass 30 kg travelling with a velocity of 1 m/s TO THE LEFT.

- (a) Use an equation from the insert to calculate the total momentum of the skaters BEFORE the collision. [3]**

Total momentum = _____ kg m/s

3 (b) After they collide the skaters move off together with a common velocity to the right. Use the equation:

$$\text{velocity} = \frac{\text{momentum}}{\text{mass}}$$

to calculate their velocity. [2]

Velocity = _____ m/s

5

4 Some students are investigating the principle of moments. They use a metre ruler and some different weights. The ruler is pivoted at its centre. To begin with they set up their experiment as shown opposite . They vary the position of the 5 N weight until the ruler is balanced.

(a)(i) State the principle of moments. [1]

4 (a)(ii)

Use an equation from the insert to calculate the moment of the 2 N weight about the pivot.

Give your answer in N cm. [2]

Moment = _____ N cm

4 (a)(iii)

Use the equation:

$$\text{distance} = \frac{\text{moment}}{\text{force}}$$

to calculate the distance that the 5 N weight must be from the pivot in order to balance the ruler. [2]

Distance = _____ cm

4 (b) The students replace the 2 N weight with a 4 N weight. Jade suggests that to balance the ruler they will have to halve the distance that the 5 N weight is from the pivot. Explain whether you agree with her suggestion. [2]

7

- 5 Nuclear power in the U.K. provides around one sixth of our total electricity. It is important as it provides a constant and reliable source of electricity to help supply the base load demand for the National Grid. The incomplete nuclear equation shows one possible fission reaction of uranium, U.

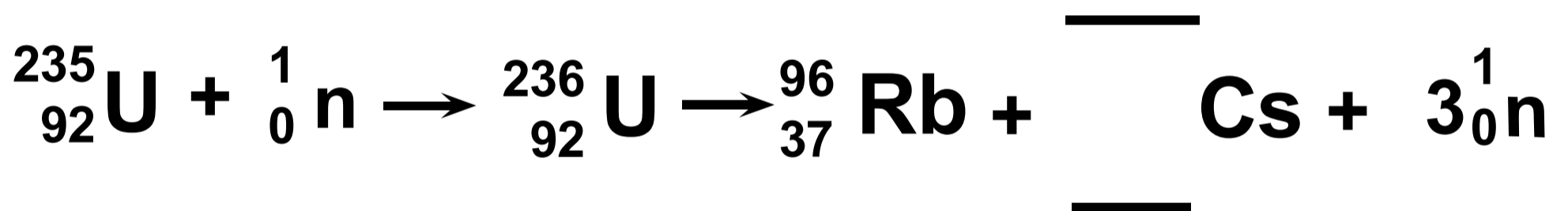

- (a) COMPLETE the nuclear equation above. [2]

5 (b)(i)

Name the particle that is absorbed by the uranium-235 nucleus. [1]

5 (b)(ii)

In a nuclear reactor on average two of the three particles, 1_0n , which are

produced in one fission are absorbed by the CONTROL RODS. Explain why this allows the nuclear reactor to operate safely. [2]

5 (c) The use of nuclear power is controversial and some people believe that we should not build any new nuclear power stations because of the radioactive waste that they produce.

State TWO properties of nuclear waste which makes storage a problem. [2]

1. _____

2. _____

5 (d) The pie chart opposite shows the sources of background radiation near a nuclear power station.

(i) State how the pie chart suggests that nuclear power is a safe source of electricity. [1]

5 (d)(ii)

Students measure the background radiation in counts per minute. One group takes a measurement for one minute. A second group measures the counts for 10 minutes and divide the value by 10. Explain which method is better. [2]

10

6 A group of students are investigating how a spring stretches when forces are applied to it. They measure the length of the spring and plot their results on a graph shown opposite.

(a)(i) Use the graph to determine the unstretched length of the spring.
[1]

Unstretched length = _____ cm

6 (a)(ii)

Use the graph and your answer to (i) to calculate the EXTENSION of the spring when a force of 2.5 N is applied to it.

[2]

Extension = _____ cm

6 (a)(iii)

Use YOUR ANSWER TO (ii) and the equation:

$$\text{spring constant} = \frac{\text{force}}{\text{extension}}$$

to calculate the spring constant in N/m. [2]

Spring constant = _____ N/m

6 (b) The students add another identical spring in parallel with the first one as shown in the diagram opposite.

They find that the spring constant is now doubled.

ADD A LINE ON THE GRAPH opposite page 22 to show their results. [2]

7

7 (a) Complete the following sentences below about the Sun by underlining the correct word or phrase in the brackets. [3]

The Sun produces heat and light by fusing

(HYDROGEN / CARBON / HELIUM)

to make

(HYDROGEN / CARBON / HELIUM).

The Sun is currently stable because the gravitational force is

(LESS THAN / BALANCED WITH /

GREATER THAN)

the combination of gas and radiation pressure.

8 Study the diagram opposite.

A class carries out an investigation into the relationship between the terminal speed of paper cake cases and their mass. They let the cake cases drop from about 20 cm above a pointer which is 1.5 m above the floor. They time how long they take to drop from the pointer to the floor. They assume that after 20 cm the cake cases will be travelling at terminal speed.

- (a) Explain, in terms of two named forces, why the cake cases travel at terminal speed. [2]**

8 (b) The students take some trial readings to help them determine the number of repeat readings they need to take.

Shown opposite are their results for 1 cake case.

(i) CIRCLE the anomalous result. [1]

(ii) Calculate the mean time. [2]

Mean time = _____ s

8 (b)(iii)

Use an equation from the insert to calculate the mean speed. [1]

Mean speed = _____ m/s

8 (c) The students then carry out their experiment. First they measure a height of 1.5 m with two metre rulers and set their pointer. They drop 1 cake case and record the time taken to drop using a stopwatch. This is repeated 5 times.

They then repeat the experiment with 2, 3, 4 and 5 cake cases in a stack to vary the mass of the cake cases.

(i) State the independent variable in this experiment. [1]

8 (c)(ii)

State ONE controlled variable in this experiment. [1]

(iii) Explain how the data could be measured more accurately. [2]

8 (d) The results from one group are shown on the graph opposite.

Angus concludes that when the mass doubles, the speed is always 1.5 times bigger. Explain whether the results support his conclusion.

Use data from the graph to support your answer. [3]

Space for calculations.

36

13

9 Study the diagram opposite.

The overall stopping distance of a car is made up of two parts:

- **the distance that the car travels when the driver is reacting (thinking distance)**
- **the distance that the car travels after the brakes have been applied (braking distance).**

continued on the following page

The graph opposite shows how the thinking distance and braking distance depend on the speed of a vehicle under good conditions.

The table below shows the conversion from mph into m/s.

Speed (mph)	20	40	60	70
Speed (m/s)	9	18	27	31

9 (a)(i)

It is suggested that both thinking distance and braking distance are directly proportional to speed.

Explain whether this suggestion is true. [2]

9 (a)(ii)

Use information on the previous pages and the equation:

$$\text{time} = \frac{\text{distance}}{\text{speed}}$$

to calculate the THINKING time of the driver when travelling at 40 mph. [3]

Thinking time = _____ s

9 (a)(iii)

Use the information on the graph opposite page 38 to complete the table opposite. [2]

(iv) Use the data in the table to PLOT the points on the grid opposite page 38 AND DRAW A LINE to show how the overall stopping distance depends on speed. [3]

- 9 (b) The speed limit along a road outside a school in Cardiff was 30 mph. The council decided to reduce this to 20 mph in 2017.

The entrance to the school is situated 15 m after a bend in the road as shown opposite.

Explain how the change in speed limit affects the chance of children getting knocked down as they cross the road outside the school entrance. Use data to support your answer. [3]

13

10 Read the information opposite.

(a) Explain why iodine-123 is unsuitable to treat prostate cancer. [2]

10 (b) Explain why iodine-131 is more suitable to treat thyroid cancer than iodine-128. [2]

10 (c) Patients are told that, after treatment with iodine-131, small amounts of radiation from their body may trigger radiation monitors until the activity has dropped to one thousandth

$\left(\frac{1}{1000}\right)$ of its initial value.

The patients are told this will occur 80 days after treatment.

Explain with the aid of a calculation whether 80 days is long enough. [3]

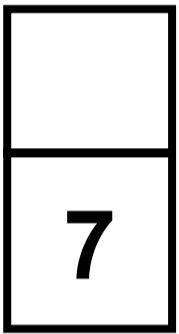
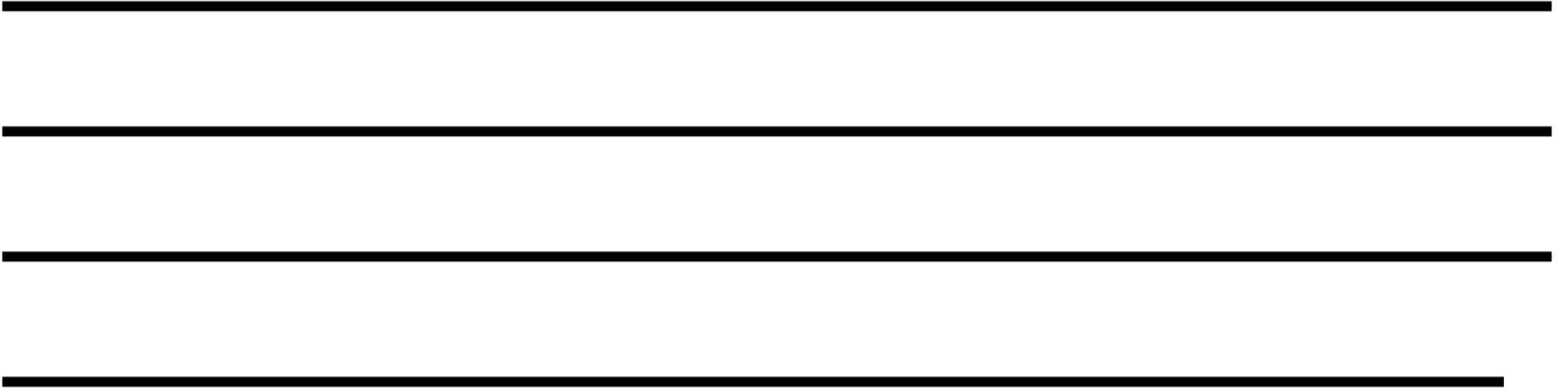

END OF PAPER

For Examiner's use only		
Question	Maximum Mark	Mark Awarded
1.	4	
2.	5	
3.	5	
4.	7	
5.	10	
6.	7	
7.	9	
8.	13	
9.	13	
10.	7	
Total	80	



Radiotherapy is used to treat cancer. Three types of radiotherapy are described below.

Brachytherapy is a type of internal radiotherapy. It involves putting a sealed radiation source inside the cancerous growth. The radioisotope used emits low energy gamma rays. An isotope of iodine (iodine-125) can be used to treat prostate cancer.

Unsealed source radiotherapy also uses radioactive substances to treat cancer. These are introduced into the body by injection or ingestion. Iodine-131 is injected into a patient to treat thyroid cancer.

External radiotherapy is different from the methods described above. It is given as a series of short, daily treatments in the radiotherapy department using high energy gamma rays.

Information about some isotopes of iodine is given below.

Iodine-123 has a half-life of 13 hours and emits gamma.

Iodine-125 has a half-life of 59 days and emits gamma.

Iodine-128 has a half-life of 25 minutes and emits beta.

Iodine-129 has a half-life of 15 000 000 years and emits beta and gamma.

Iodine-131 has a half-life of 8 days and emits beta and gamma.

Before collision

5 m/s



50 kg

1 m/s



30 kg

Direction of positive velocity

After collision

velocity



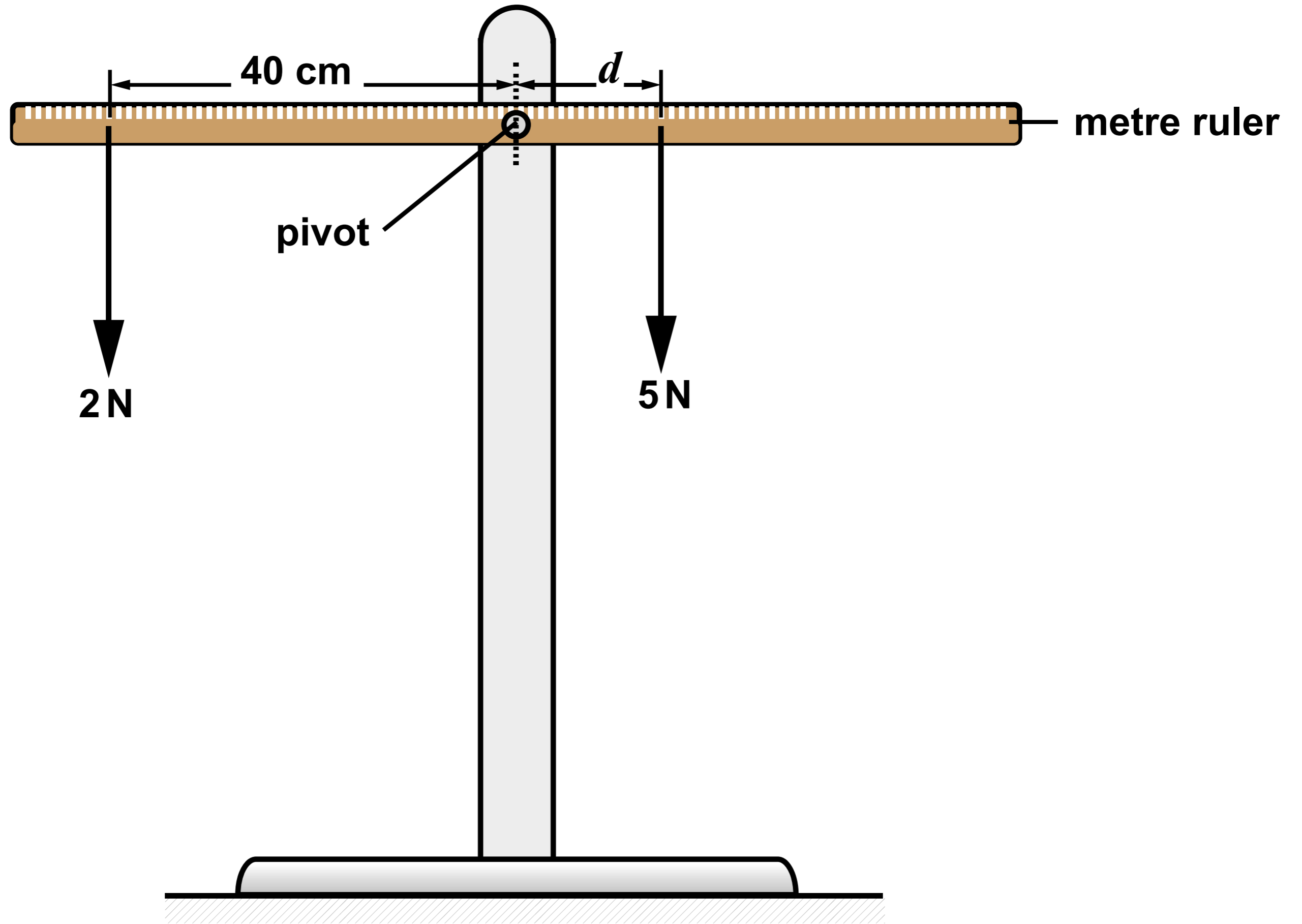

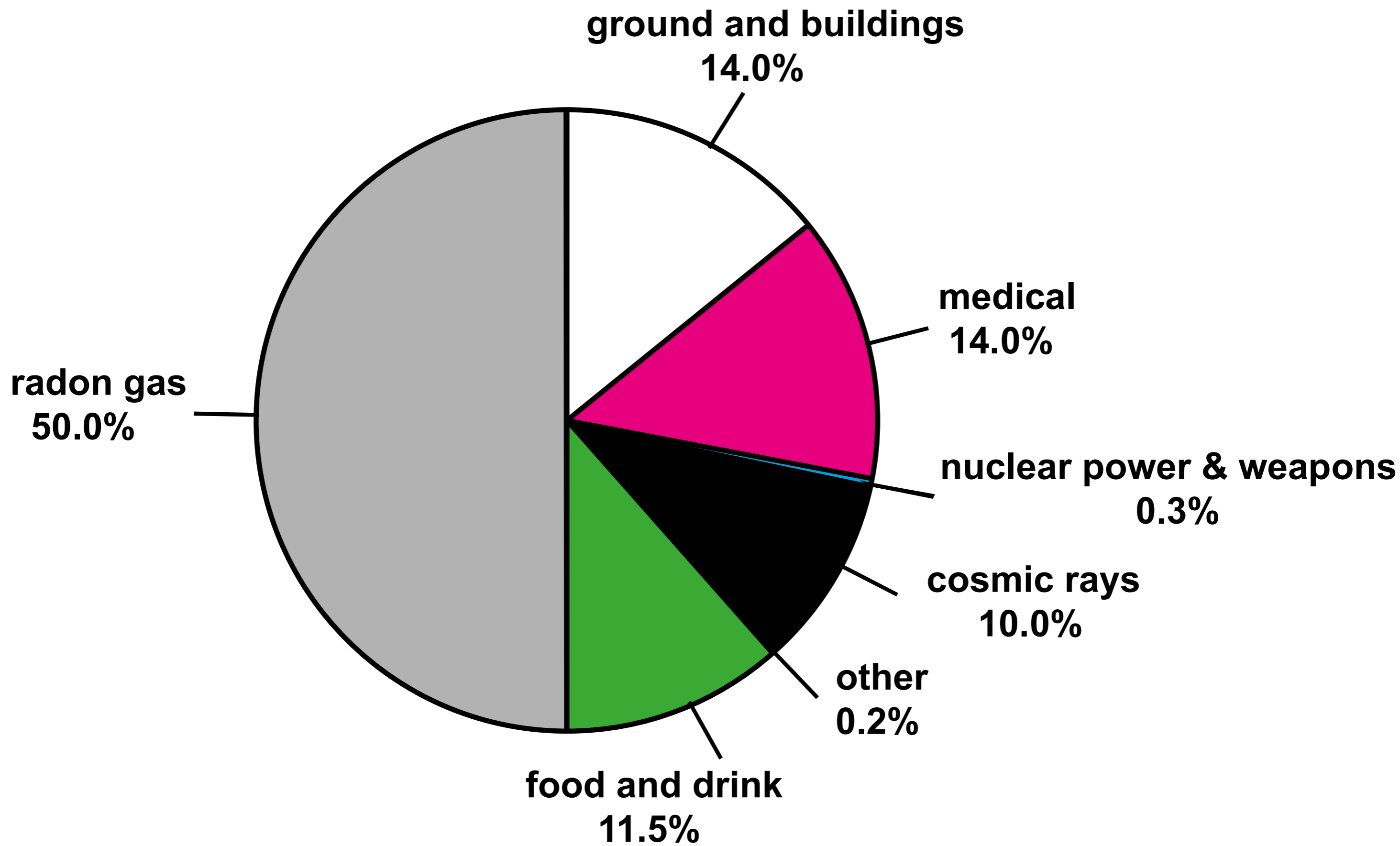

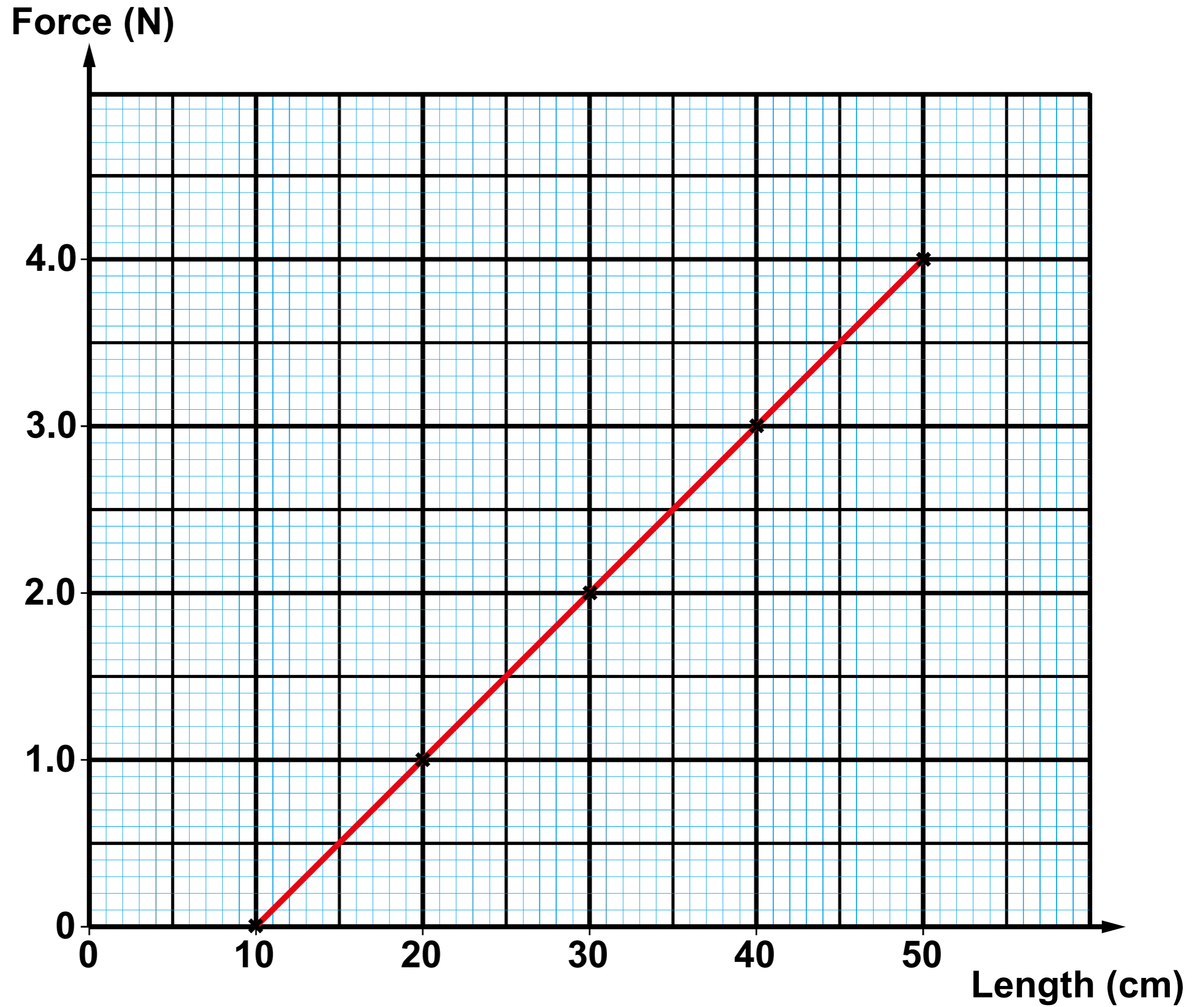
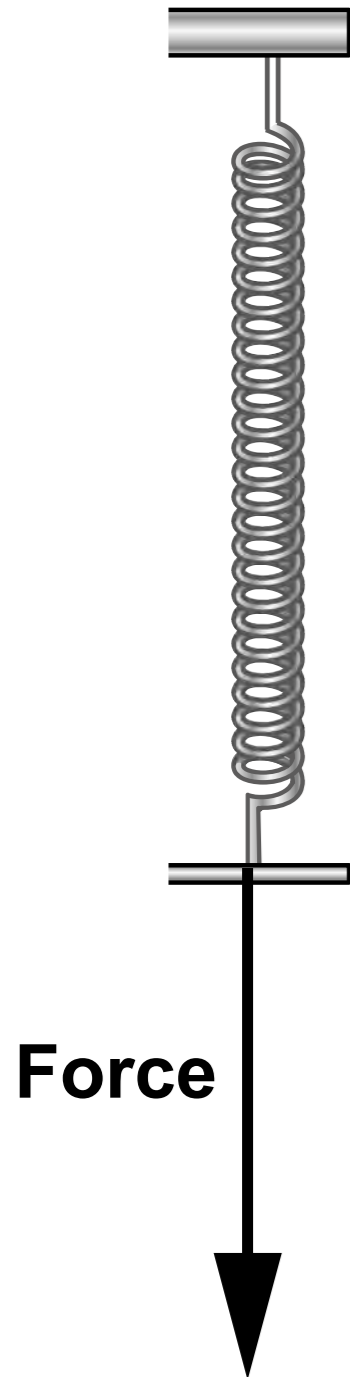

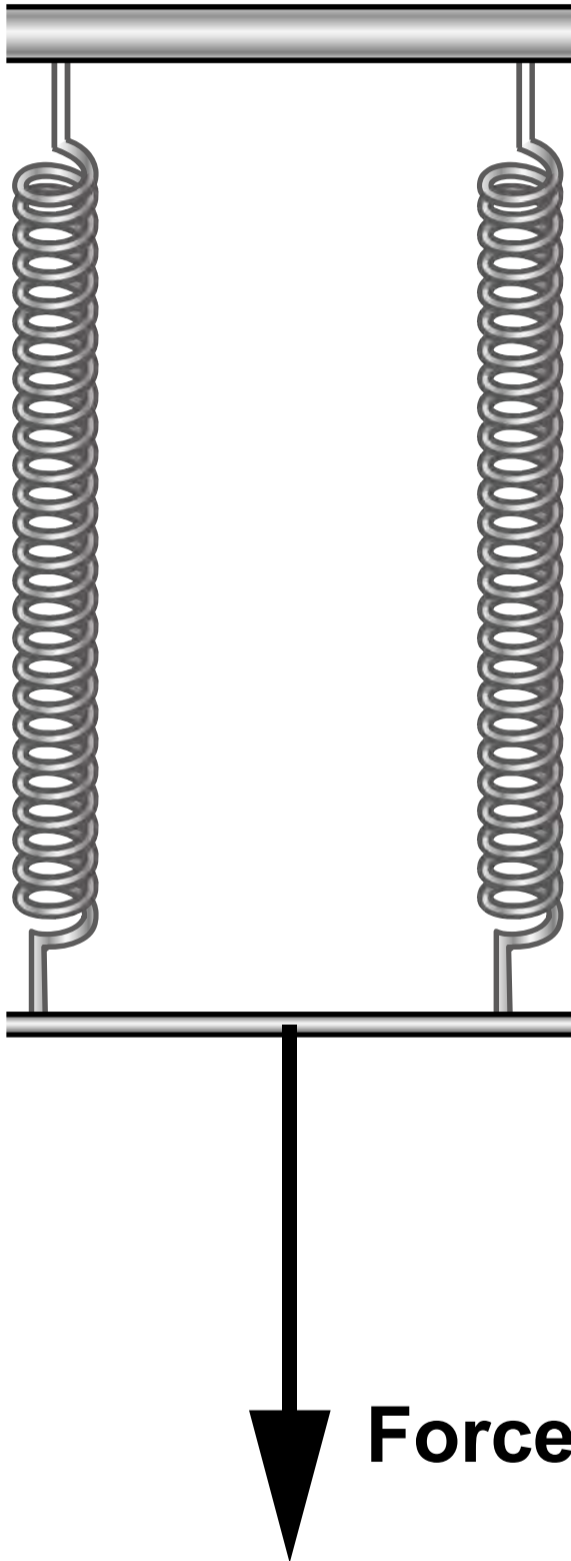

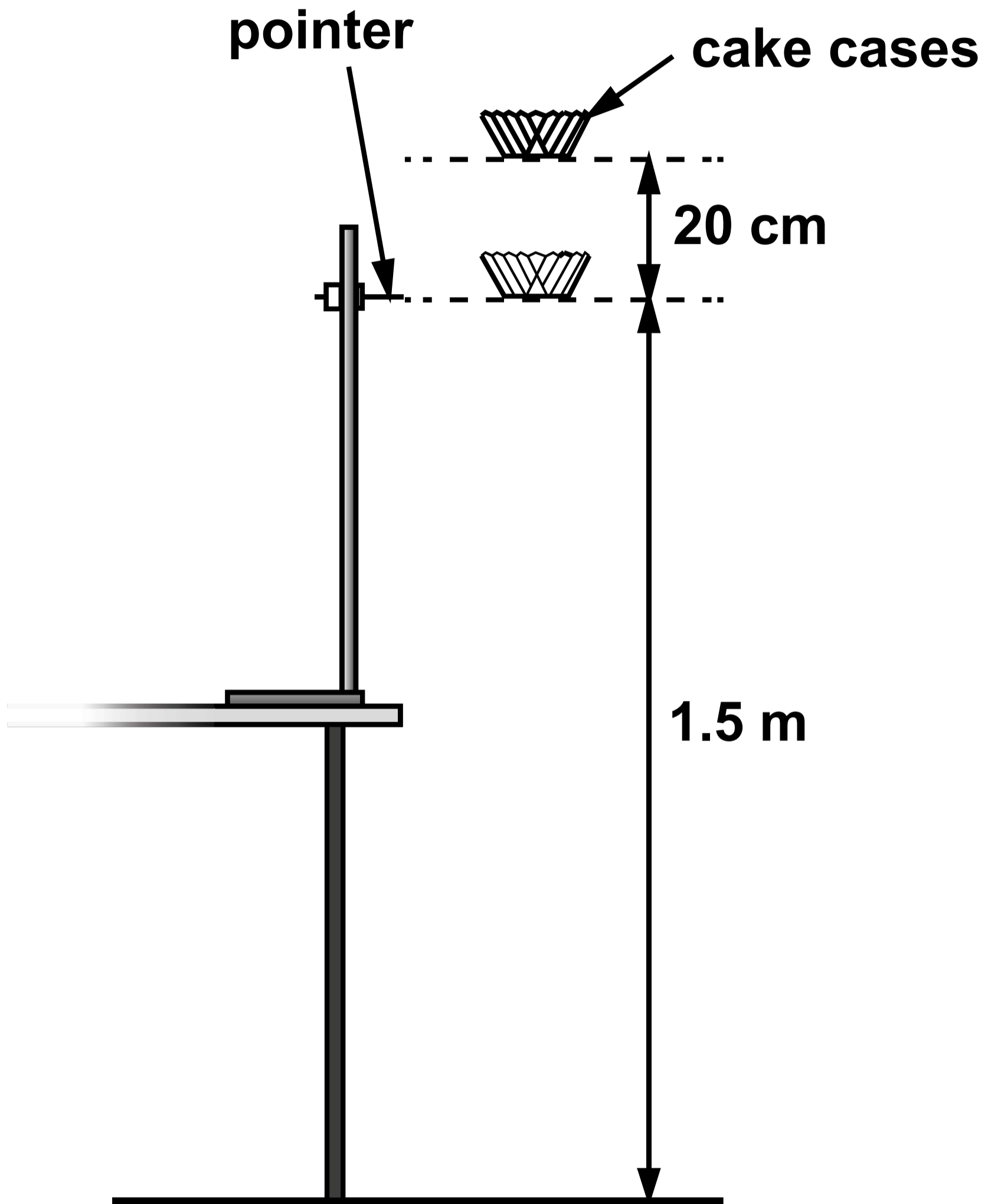

Mass (g)	Time for cake case to travel 1.5 m (s)							
	Trial 1	Trial 2	Trial 3	Trial 4	Trial 5	Trial 6	Trial 7	Trial 8
0.5	1.16	1.19	1.17	1.29	0.72	1.22	1.24	1.15

Speed (m/s)

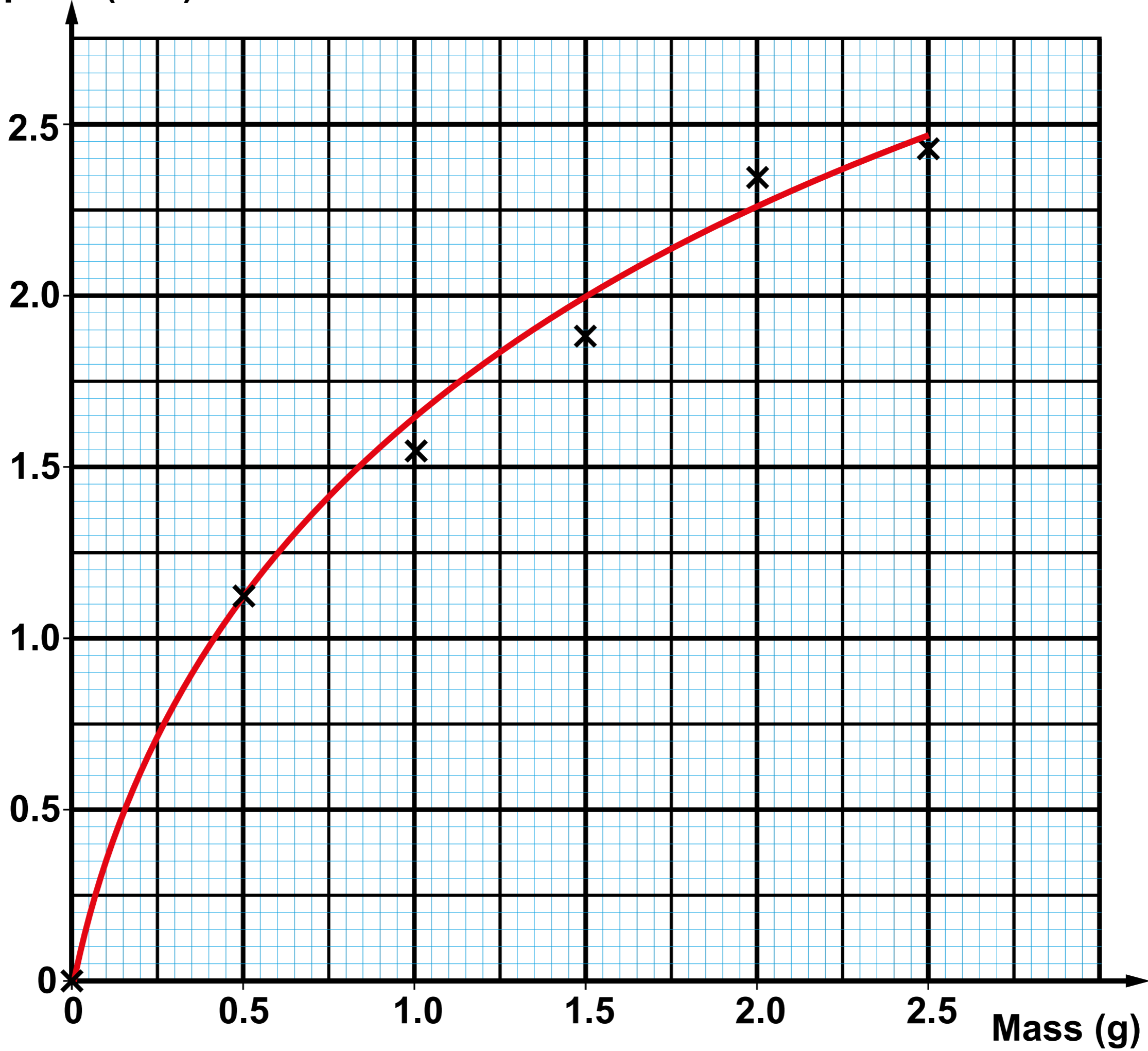

Mass (g)

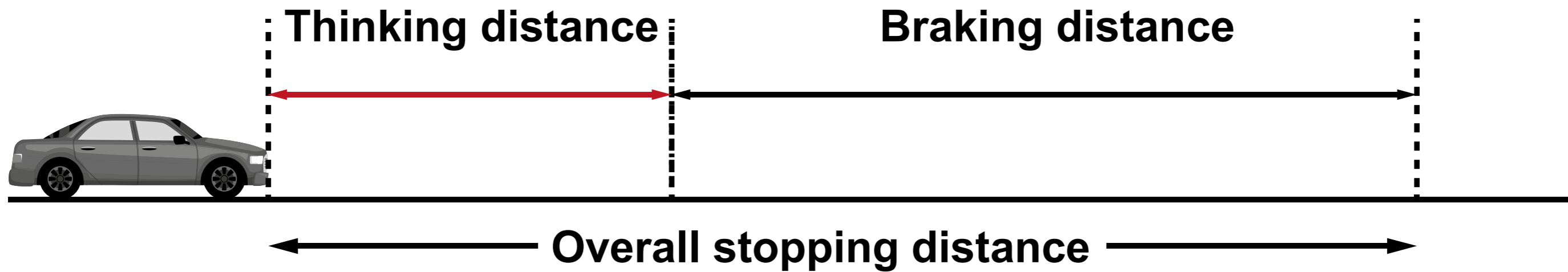

Speed (mph)	0	20	30	40	60	70
Overall stopping distance (m)	_____	_____	_____	_____	_____	_____

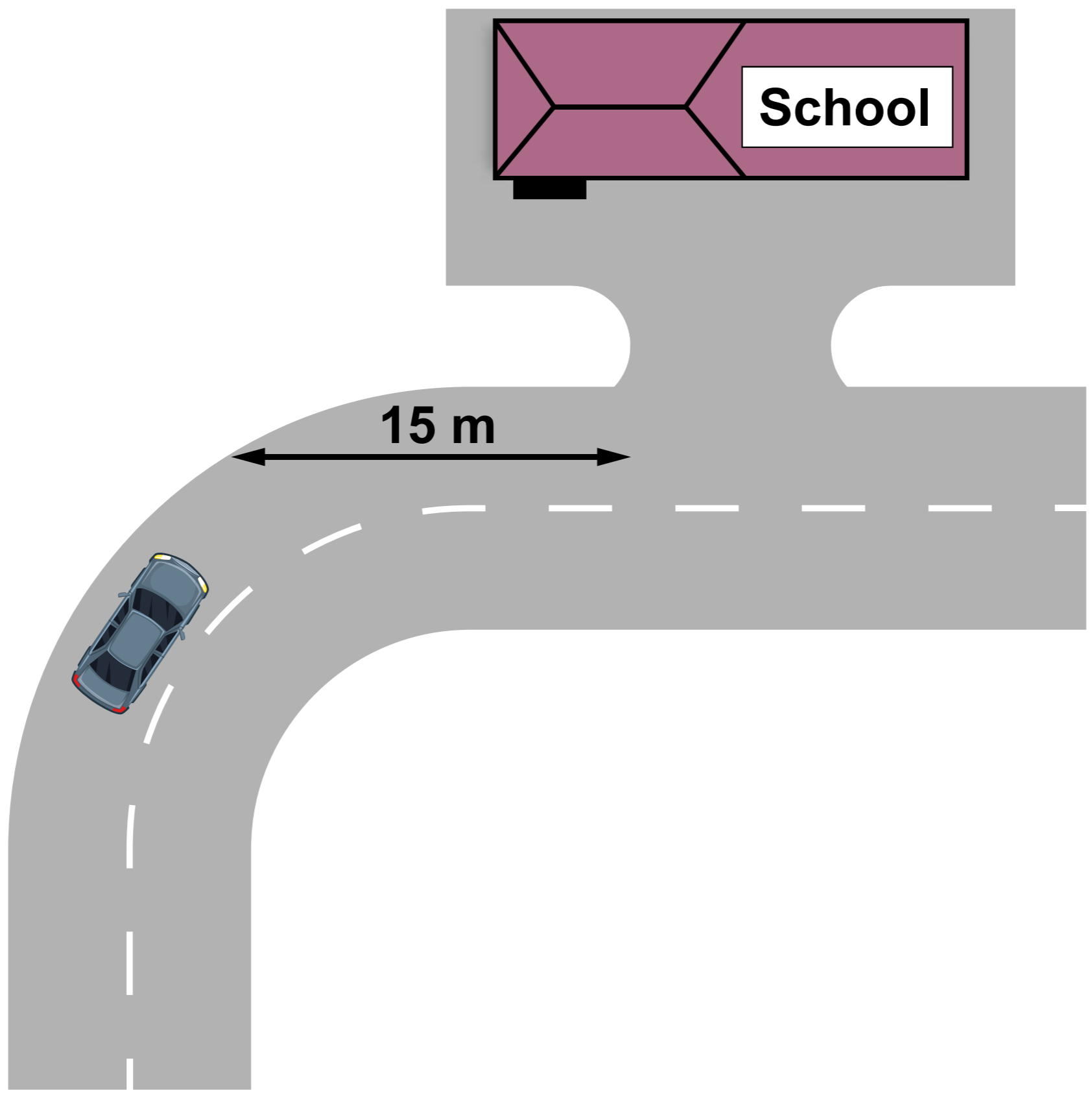

School

15 m

Distance (m)

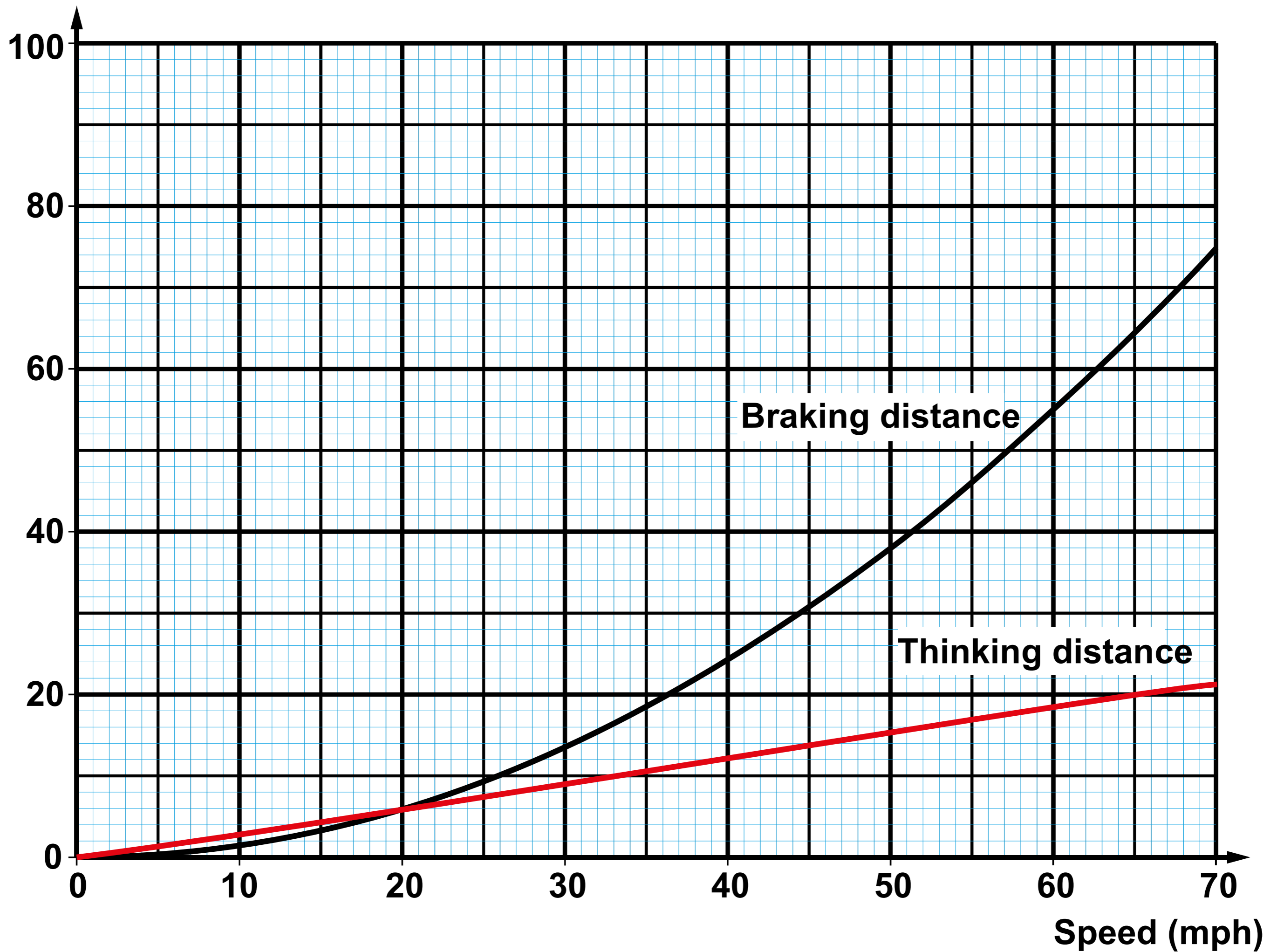

Braking distance

Thinking distance

Speed (mph)



GCSE

3420U20-1

PHYSICS – Unit 2

Forces, Space and Radioactivity

FOUNDATION TIER

WEDNESDAY, 22 MAY 2019 – AFTERNOON

INSERT

EQUATIONS

speed = $\frac{\text{distance}}{\text{time}}$	
acceleration [or deceleration] = $\frac{\text{change in velocity}}{\text{time}}$	$a = \frac{\Delta v}{t}$
acceleration = gradient of a velocity-time graph	
resultant force = mass x acceleration	$F = ma$
weight = mass x gravitational field strength	$W = mg$
work = force x distance	$W = Fd$
force = spring constant x extension	$F = kx$
momentum = mass x velocity	$p = mv$
force = $\frac{\text{change in momentum}}{\text{time}}$	$F = \frac{\Delta p}{t}$
<p>u = initial velocity v = final velocity t = time a = acceleration x = displacement</p>	<p>$v = u + at$ $x = \frac{u + v}{2} t$</p>
moment = force x distance	$M = Fd$

SI MULTIPLIERS

Prefix	Multiplier
m	1×10^{-3}
k	1×10^3
M	1×10^6