

FOR OFFICIAL USE



National
Qualifications
2025

Mark

X860/75/02

Practical Electronics

MONDAY, 12 MAY

1:30 PM – 2:30 PM



* X 8 6 0 7 5 0 2 *

Fill in these boxes and read what is printed below.

Full name of centre

Town

Forename(s)

Surname

Number of seat

Date of birth

Day

Month

Year

Scottish candidate number

Total marks — 60

Attempt ALL questions.

You may use a calculator.

Write your answers clearly in the spaces provided in this booklet. Additional space for answers is provided at the end of this booklet. If you use this space you must clearly identify the question number you are attempting.

Use **blue** or **black** ink.

Before leaving the examination room you must give this booklet to the Invigilator; if you do not, you may lose all the marks for this paper.





* X 8 6 0 7 5 0 2 0 1 *

Total marks — 60
Attempt ALL questions

1. The table below gives information about some circuit components.
 Some of the boxes have been left blank.

(a) Complete the table for the missing entries.

3

Component name	Symbol	Function
Bipolar transistor		electronic switch
Cell		
		measures voltage across a circuit
Lamp		converts electrical energy into light energy

1. (continued)

(b) A pupil selects a resistor with the colour coding as shown below.

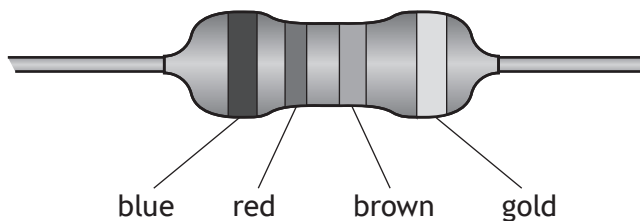

Use the information in the data sheet to answer the questions below.

(i) Determine the resistance of the resistor.

1

(ii) State the percentage tolerance of this resistor.

1

(iii) Determine the maximum and minimum resistance of this resistor in ohms.

2

[Turn over



2. The table below shows information about the resistance of a thermistor at different temperatures.

MARKS DO NOT WRITE IN THIS MARGIN

Temperature (°C)	Resistance (kΩ)
20	50.0
40	30.0
60	
80	10.0

Complete the table above to predict the resistance of the thermistor at 60 °C.

1

3. A circuit diagram is shown below.

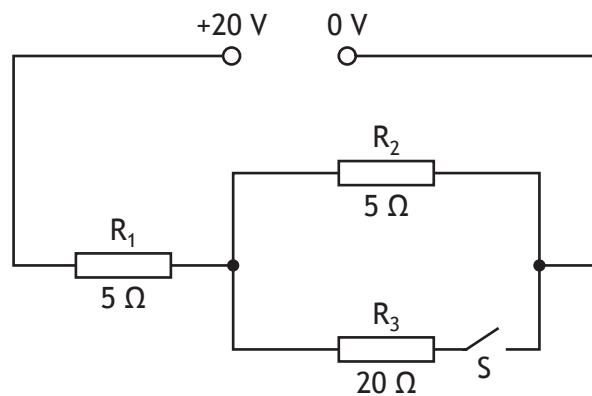

- (a) Switch S is open.

- (i) Calculate the total resistance of this circuit.

1

Space for working and answer

- (ii) Calculate the current in this circuit.

3

Space for working and answer



3. (a) (continued)

(iii) Calculate the power dissipated in resistor R_1 .

Space for working and answer

3

(b) Switch S is now closed.

(i) Calculate the effective resistance of R_2 and R_3 in parallel.

Space for working and answer

3

(ii) Calculate the overall circuit resistance.

Space for working and answer

1

[Turn over



4. There are many different types of logic gate used in electronics.

(a) Complete the truth table for an NOR gate.

1

A	B	Output
0	0	
0	1	
1	0	
1	1	

(An additional truth table, if required, can be found on page 20.)

(b) A logic gate is shown below, with given logic states.

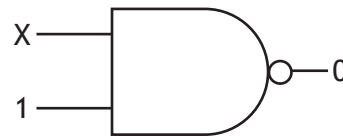

Determine the logic state of X that would produce the output shown.

1

4. (continued)

(c) Complete the truth table for the logic circuit shown below.

4

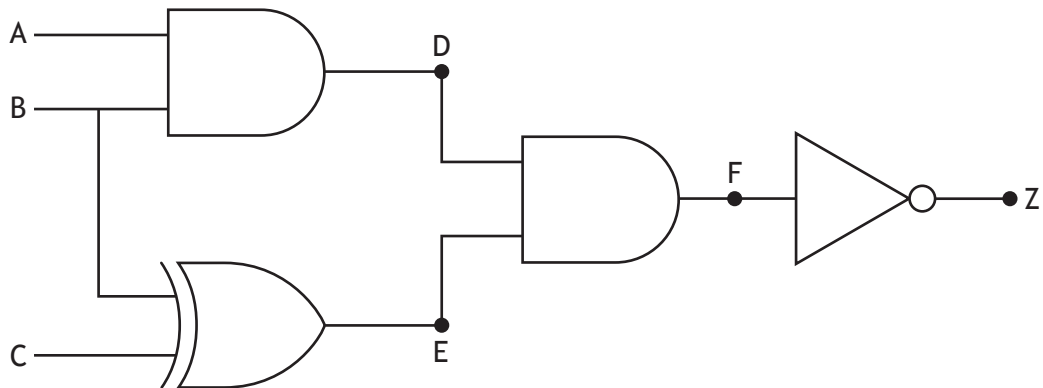

A	B	C	D	E	F	Z
0	0	0				
0	0	1				
0	1	0				
0	1	1				
1	0	0				
1	0	1				
1	1	0				
1	1	1				

(An additional truth table, if required, can be found on page 20.)

[Turn over

5. A student produces a simulation of a circuit that will turn on an LED when it gets too cold in a greenhouse.
 However, the simulation does not work as specified.
 Identify **four** errors in the student's simulation shown below.

4

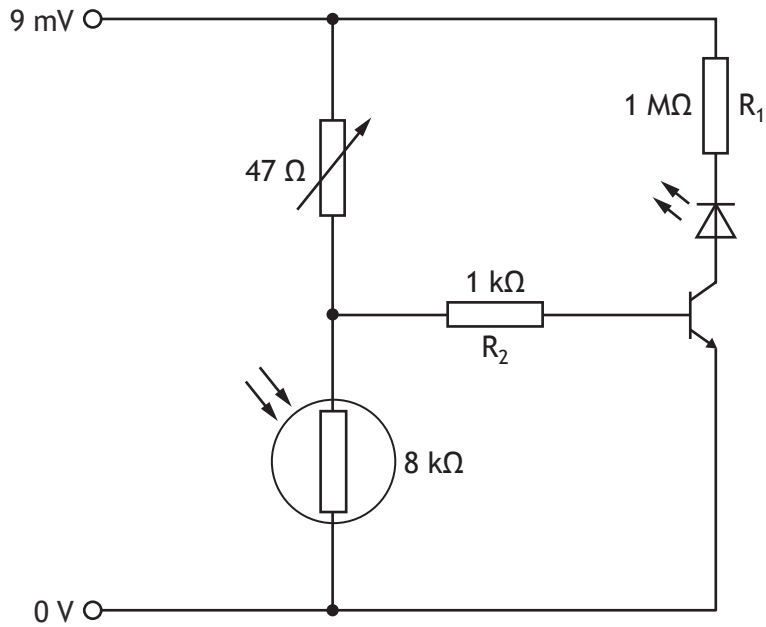

Error 1:

Error 2:

Error 3:

Error 4:



6. The image below shows the wiring connections between a stripboard and a motor for a circuit.

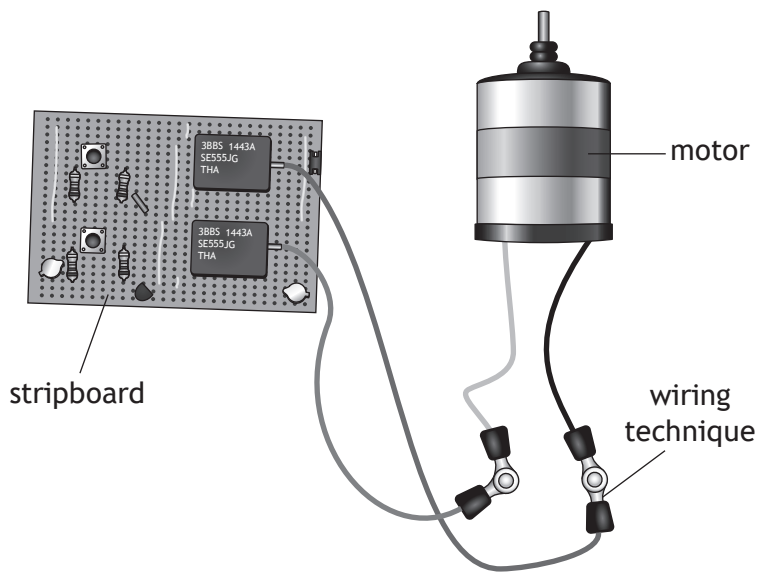

The wiring technique used in the photo is crimping.

(a) State another wiring technique that could have been used to secure the wires together.

1

(b) State one method that could be used to identify the correct wiring between the stripboard and motor.

1

[Turn over



7. A logic probe, shown below, is used to test the inputs and outputs of a 74 series logic chip.
The logic probe is set to TTL and pulse.

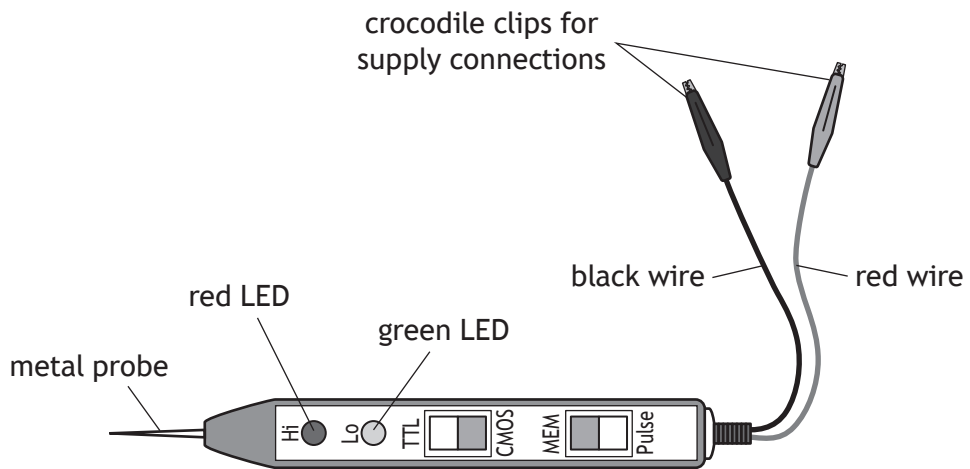

- (a) (i) State where the red and black wires should be connected.

1

- (ii) Describe how a logic 1 would be detected.

2

7. (continued)

(b) A student sets up a circuit on stripboard as shown below. IC₁ is a 74 series logic chip.

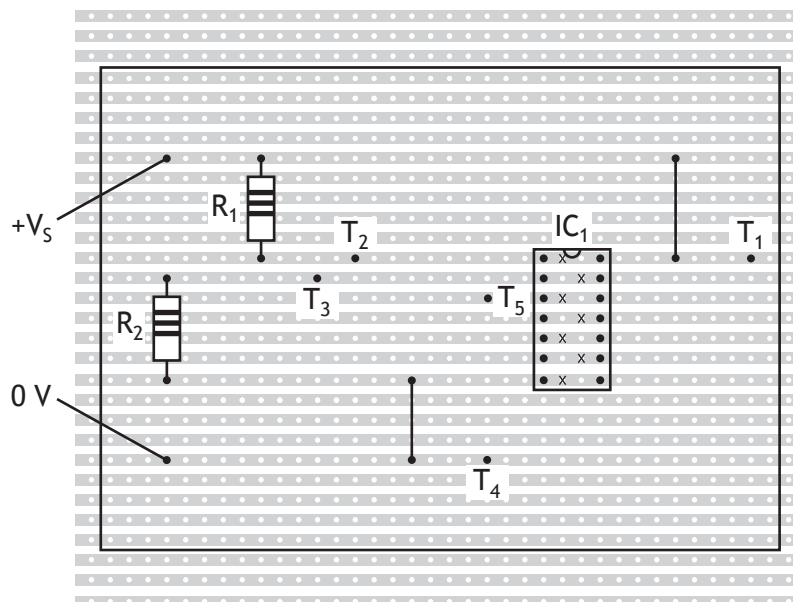

Test points T₁ to T₅ are marked on the stripboard.

(i) Identify two test points that are used to measure the voltage across R₂. 1

(ii) The logic probe is placed at pin 7 of the logic chip, IC₁.
Explain why the LED on the logic probe flashes green. 1

[Turn over

8. The output from a signal generator is connected to the input terminals of an oscilloscope.
 The trace is shown on the screen.
 The Y-gain and timebase settings are shown below.

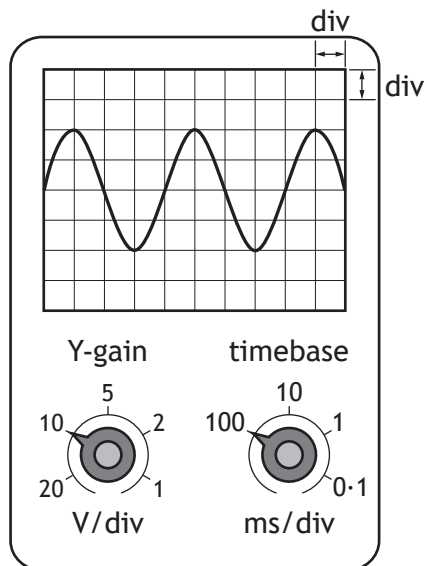

- (a) Determine the peak voltage of this signal.

1

- (b) Calculate the frequency of the signal.

3

Space for working and answer



[Turn over for next question

DO NOT WRITE ON THIS PAGE



* X 8 6 0 7 5 0 2 1 3 *

9. An LDR is used as a light sensor in a circuit to monitor and control the automatic mode setting of a car's headlights. Part of the circuit is shown below.

MARKS DO NOT WRITE IN THIS MARGIN

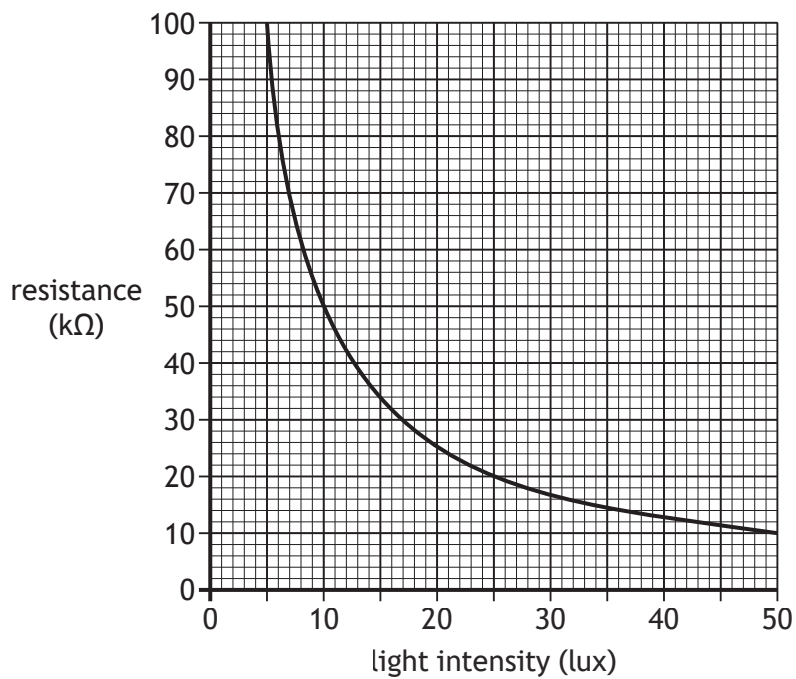
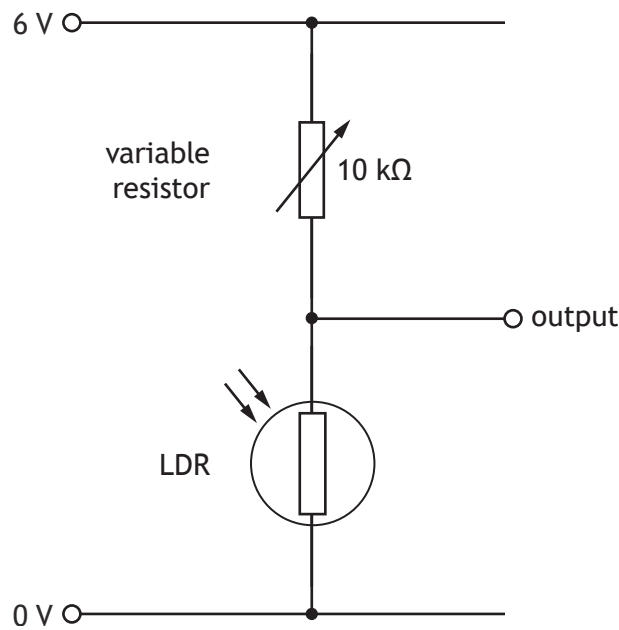

- (a) (i) The graph above shows how the resistance of the LDR varies with the light intensity, measured in lux.

Use the graph to determine the resistance of the LDR when the light intensity is 25 lux.

1



9. (a) (continued)

MARKS DO NOT WRITE IN THIS MARGIN

(ii) The variable resistor is now set at a resistance of $10\text{ k}\Omega$.

Calculate the voltage across the LDR when the light intensity is kept at 25 lux.

3

Space for working and answer

(b) The potential divider is now connected to a switching circuit via the car battery to operate the car lights, as shown below.

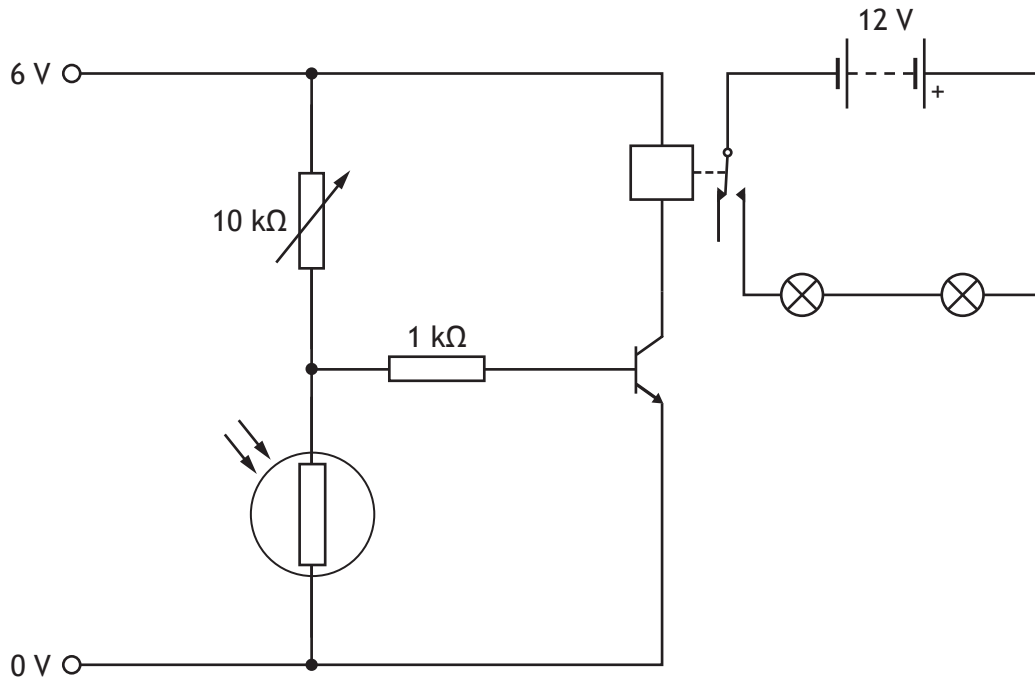

(i) Explain how the circuit operates in order to switch on the car lights when the light intensity falls below a certain value.

3



9. (b) (continued)

- (ii) The operation of the circuit can be improved by the addition of one component connected in parallel with the relay.

Name this component.

1



* X 8 6 0 7 5 0 2 1 6 *

10. A gas pipeline mechanism is required to detect gas leaks.

When a leak is detected, the gas should be switched off by a motor.

The system must include a gas sensor to monitor for any leaks.

The gas can be switched off when either an engineer presses an emergency switch or when the gas sensor detects gas.

If the gas is switched off, an audible alert should also be sounded.

Selecting from the elements given below, draw a block diagram of an electronic solution for this system.

On your diagram, clearly indicate the input, process and output sections of your solution.

6

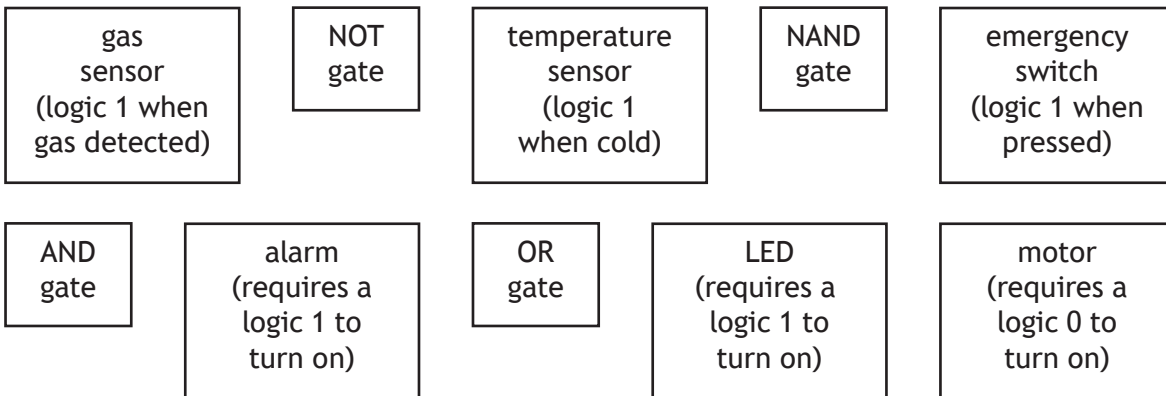

11. The stripboard plan below shows a **component (top) view** of a circuit with the following layout.

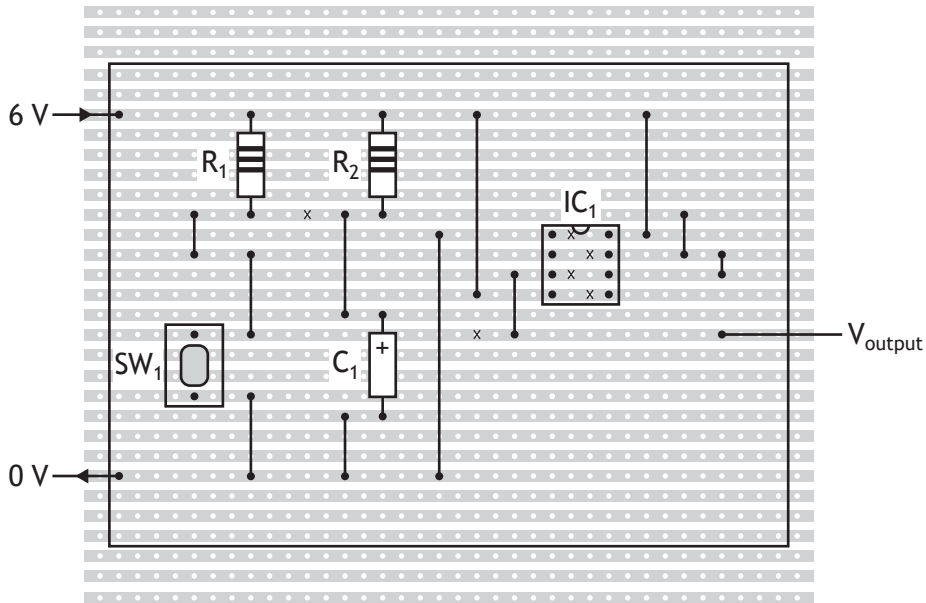

Component data

IC₁ — NE555

R₁ and R₂ — carbon film 10 KΩ 0.25 W

C₁ — 1000 μF 16 V **electrolytic** capacitor

SW₁ — push-to-make switch

X shows where a track has been cut.

Circuit symbol for IC₁

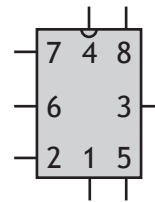

Circuit symbol for SW₁

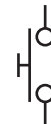

11. (continued)

For the stripboard layout diagram, complete the circuit diagram below.

Each component must be labelled.

(An additional circuit diagram template, if required, can be found on *page 21*.)

6

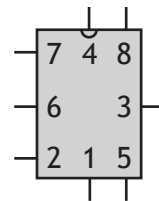

[END OF QUESTION PAPER]



ADDITIONAL SPACE FOR ANSWERS

Additional truth table for question 4(a)

A	B	Output
0	0	
0	1	
1	0	
1	1	

Additional truth table for question 4(c)

A	B	C	D	E	F	Z
0	0	0				
0	0	1				
0	1	0				
0	1	1				
1	0	0				
1	0	1				
1	1	0				
1	1	1				

ADDITIONAL SPACE FOR ANSWERS

Additional circuit diagram template for question 11

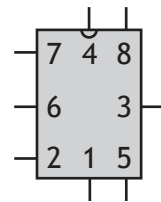

MARKS DO NOT
WRITE IN
THIS
MARGIN

ADDITIONAL SPACE FOR ANSWERS



MARKS DO NOT
WRITE IN
THIS
MARGIN

ADDITIONAL SPACE FOR ANSWERS



[BLANK PAGE]

DO NOT WRITE ON THIS PAGE

