



National
Qualifications
2025

X840/76/12

**Human Biology
Paper 1 — Multiple choice**

TUESDAY, 27 MAY

9:00 AM – 9:40 AM

Total marks — 25

Attempt ALL questions.

You may use a calculator.

Instructions for the completion of Paper 1 are given on *page 02* of your answer booklet X840/76/02.

Record your answers on the answer grid on *page 03* of your answer booklet.

Space for rough work is provided at the end of this booklet.

Before leaving the examination room you must give your answer booklet to the Invigilator; if you do not, you may lose all the marks for this paper.



* X 8 4 0 7 6 1 2 *

Total marks — 25
Attempt ALL questions

1. The diagram shows part of a DNA molecule.

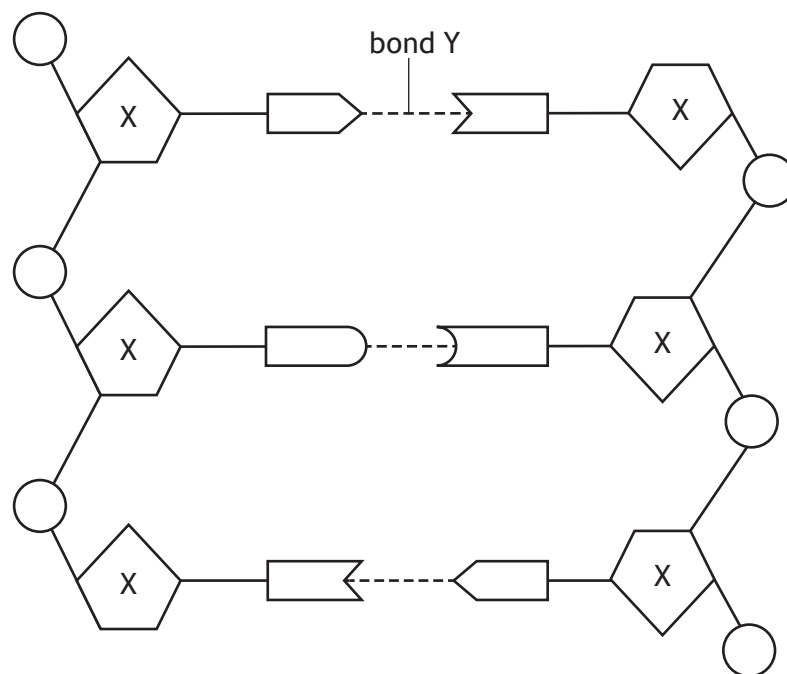

Which row in the table identifies sugar X and bond Y?

	Sugar X	Bond Y
A	deoxyribose	hydrogen
B	ribose	peptide
C	deoxyribose	peptide
D	ribose	hydrogen

2. The role of DNA polymerase is to

- A remove introns from a primary mRNA transcript
- B add DNA nucleotides to a new DNA strand being formed
- C synthesise a primary mRNA transcript during transcription
- D join DNA fragments together during replication of the lagging strand.

3. The graph shows the percentage of new cases of testicular cancer and the percentage survival rate across a range of age groups.

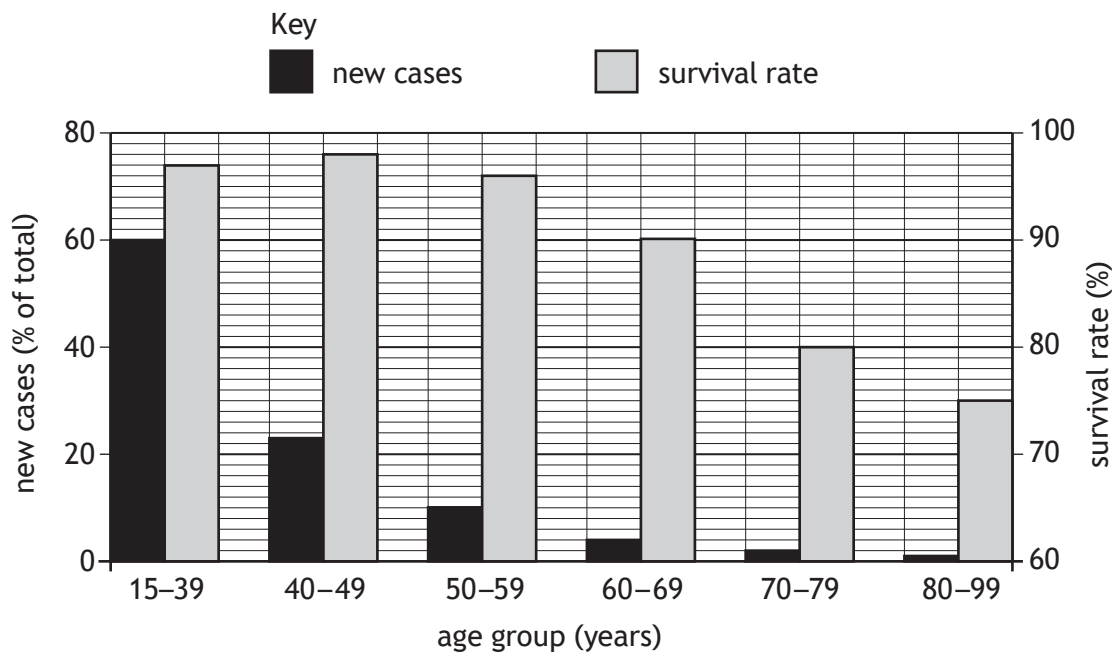

Which of the following is correct for this data?

- A The ratio of survival rate to new cases for age group 50–59 is 48:5.
- B The difference in survival rate between age groups 60–69 and 70–79 is 20%.
- C The percentage of new cases at age group 40–49 is double that of age group 50–59.
- D The age group with the highest percentage of new cases has the highest survival rate.
4. Which types of RNA can be found in the cytoplasm?
- A mRNA only
- B tRNA and rRNA only
- C mRNA and rRNA only
- D mRNA, tRNA and rRNA
5. The nucleic acids involved in gene expression are listed.

1. DNA
2. mRNA
3. tRNA
4. rRNA

Which nucleic acids are involved in the transcription stage of gene expression?

- A 1 only
- B 1 and 2 only
- C 1, 2 and 3 only
- D 1, 2, 3 and 4

6. PCR is a reaction that amplifies a section of DNA and involves several temperature changes per cycle.

The reaction stays at each temperature for 2 minutes.

Calculate the total number of minutes taken to produce 128 copies of one DNA section.

- A 14
B 21
C 42
D 64
7. Pharmacogenetics is the use of
- A gene sequences to assess the likelihood of passing on a disease
B computer programs to assess the likelihood of passing on a disease
C gene sequences to select appropriate drug and dosage to treat a disease
D computer programs to identify base sequences of known genetic diseases.
8. The diagram shows the metabolic pathway that converts the amino acid threonine into isoleucine.

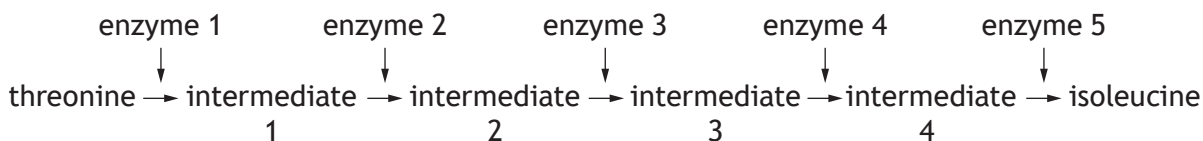

An increased production of isoleucine would be caused by

- A isoleucine acting as a competitive inhibitor of enzyme 2
B negative feedback inhibition of threonine by isoleucine
C an increased concentration of isoleucine
D an increased concentration of threonine.
9. During vigorous exercise not enough oxygen is delivered to cells to support the electron transport chain.
- To allow glycolysis to continue, pyruvate is converted to
- A acetyl, generating NAD
B lactate, generating NAD
C acetyl, generating NADH
D lactate, generating NADH.

10. A typical slow-twitch muscle fibre that took 100 milliseconds (ms) to complete one contraction was compared to a fast-twitch muscle fibre that took 75 ms.
Calculate how many more times a fast-twitch muscle fibre can contract in one minute compared to a slow-twitch muscle fibre.

(1000 ms = 1 second)

- A 25
- B 200
- C 800
- D 1500

11. A sample of muscle fibres from the thigh of an Olympic sprinter was analysed and compared to a sample from an elite long-distance runner.

Which row in the table shows the expected results?

	Myoglobin concentration	Glycogen concentration	Number of mitochondria
A	lower	higher	lower
B	higher	lower	higher
C	lower	higher	higher
D	higher	lower	lower

[Turn over

12. The graph shows the changes in the average sperm count of males in a country.

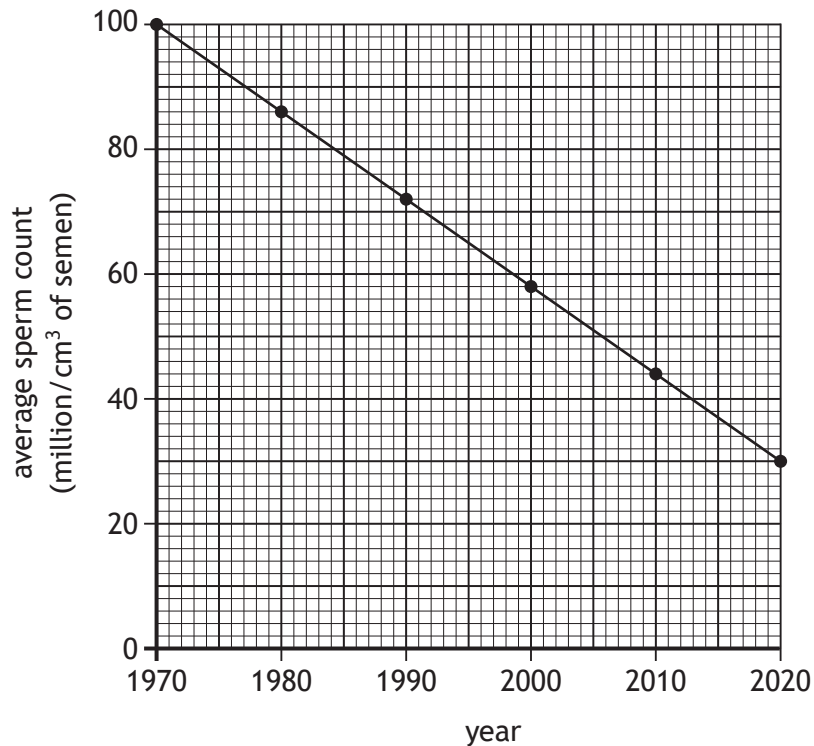

Which of the following statements is correct?

- A The average sperm count decreased by 14% between 1980 and 1990.
- B The average sperm count decreased by 60 million/cm³ between 1970 and 2010.
- C The average sperm count will be 16 million/cm³ in 2025 if the current trend continues.
- D The average sperm count has decreased by 1.4 million/cm³/year between 1970 and 2020.

13. A study was carried out to investigate the effects of different fertility drugs on sperm count. 12 000 males participated and they were randomly split into three groups of 4000.

Each group was given a different fertility drug.

It was discovered that many participants had also taken additional fertility supplements during the study.

From the information given, it was expected that the study would be

- A valid and reliable
- B valid but not reliable
- C not valid but reliable
- D not valid and not reliable.

14. Which row in the table identifies a type of routine ultrasound scan and the stage in pregnancy when it is normally carried out?

	Scan	Stage in pregnancy (weeks)
A	anomaly	8–14
B	dating	14–18
C	anomaly	18–20
D	dating	18–20

15. The diagram shows the inheritance of sickle cell in three generations of a family.

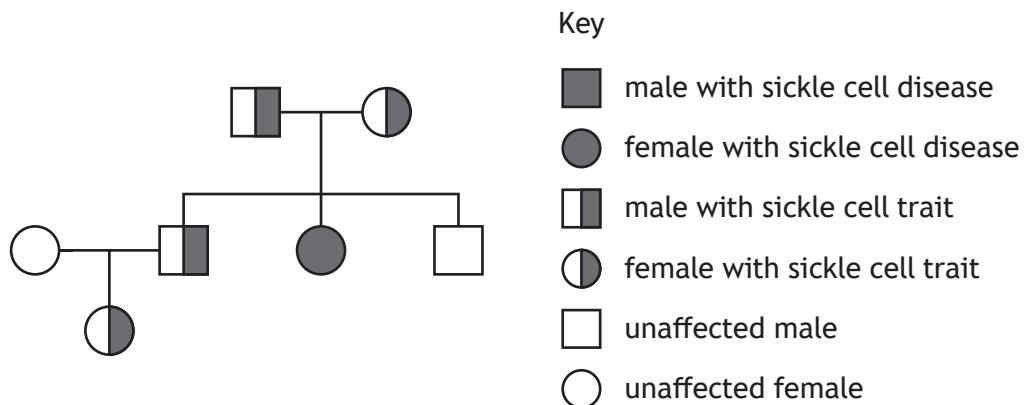

Identify the type of inheritance for sickle cell.

- A Autosomal recessive
- B Sex-linked recessive
- C Autosomal dominant
- D Incomplete dominance

[Turn over

16. The diagram shows a blood capillary, tissue cells and a lymphatic vessel.

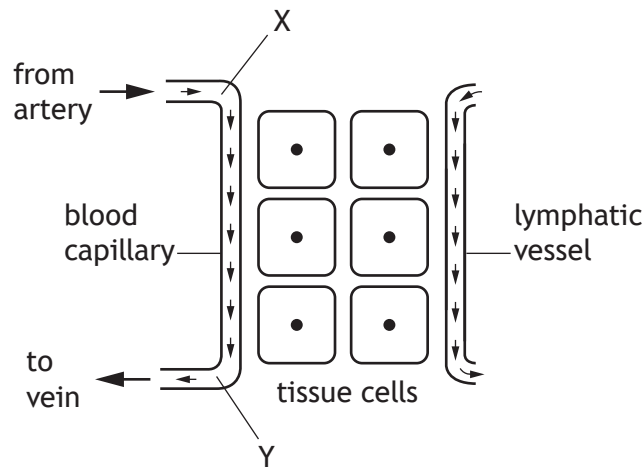

Which of the following statements explains the difference in blood pressure between points X and Y?

- A Blood pressure is higher at Y than X as plasma enters the blood between X and Y.
- B Blood pressure is higher at X than Y as plasma leaves the blood between X and Y.
- C Blood pressure is lower at X than Y as tissue fluid leaves the blood between X and Y.
- D Blood pressure is lower at Y than X as lymph enters the blood between X and Y.

17. The diagram shows some stages that occur during the control of blood glucose levels. Identify the stage that may **not** occur in an individual with type 2 diabetes.

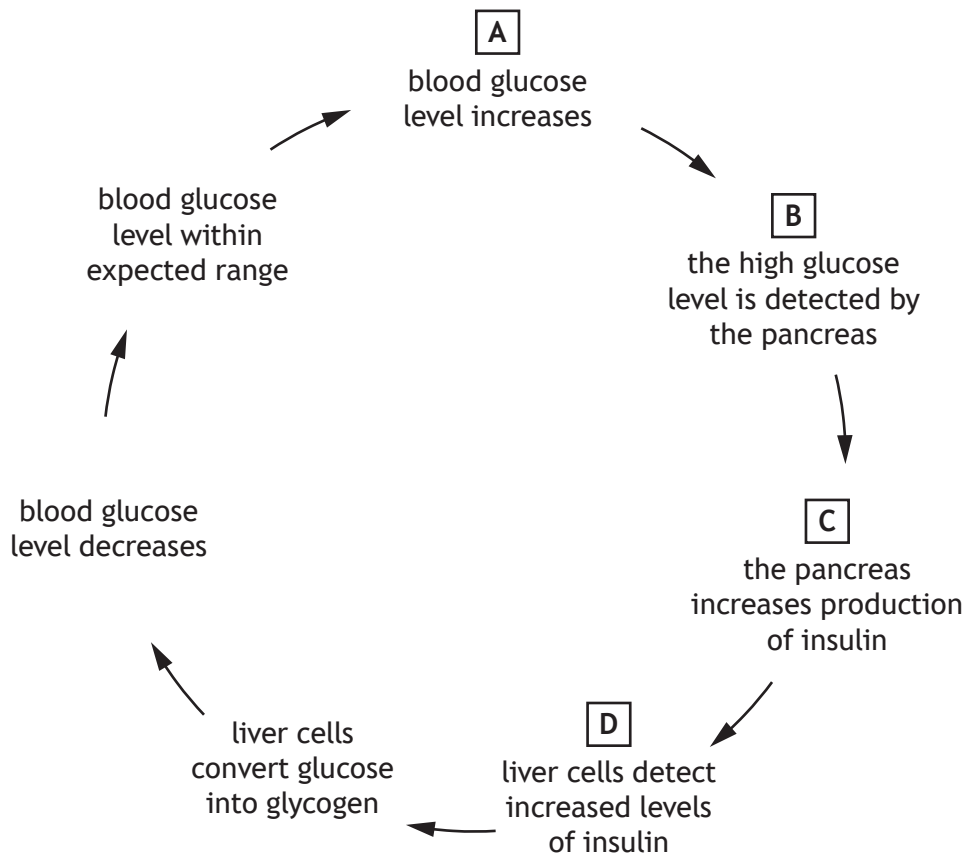

18. The diagram shows the direction of impulse transmission through a hand when the fingers are being used to type on a keyboard.

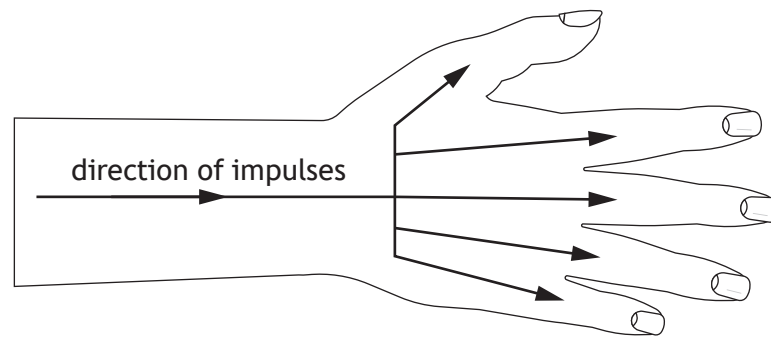

The fine motor control of the fingers occurs because of

- A summation of weak stimuli
 - B diverging neural pathways
 - C converging neural pathways
 - D reverberating neural pathways.
19. The table shows the number of individuals of different age groups diagnosed with dementia in a country over 4 years.

		Number of individuals diagnosed with dementia		
		51–65	66–80	Over 80
Year	Age group			
2016		4421	5210	3256
2017		4821	4925	3111
2018		5012	5222	2965
2019		5123	5600	2709

Which of the following statements is correct?

- A The total number of individuals diagnosed with dementia increased every year.
- B More individuals were diagnosed with dementia in 2016 than in any other year.
- C More individuals aged 51–80 were diagnosed with dementia in 2019 compared to 2016.
- D More individuals were diagnosed with dementia between the ages of 51–65 than other age categories.

[Turn over

20. The table shows the concentration of a drug measured in the blood of an individual every hour for 4 hours after the drug was taken.

Time since taken (hours)	Concentration of drug in blood (mg/L)
0	36
1	34
2	30
3	24
4	16

Predict the concentration of the drug remaining in the blood at 5 hours.

- A 6
 - B 8
 - C 10
 - D 16
21. The role of mast cells is to
- A engulf pathogens
 - B release histamine
 - C produce antibodies
 - D cause vasoconstriction.

22. An individual's white blood cell count was measured during the course of an infection. Initially the white blood cell count was within the normal range of 5000–10 000 cells/mm³. Two days later it had increased to 15 000 cells/mm³. After four days it fell to 3000 cells/mm³ before gradually increasing to within the normal range over the next six days.

Which graph shows these changes in the individual's white blood cell count?

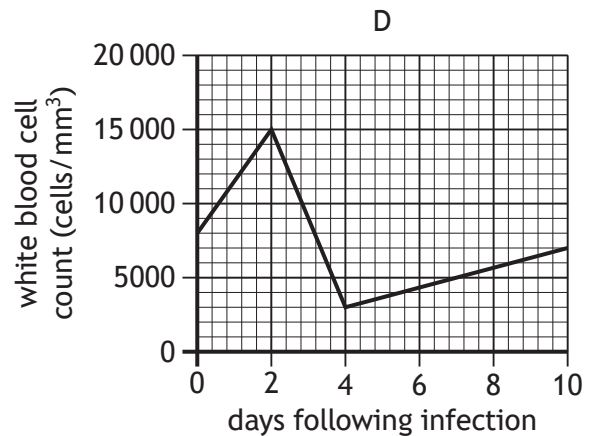
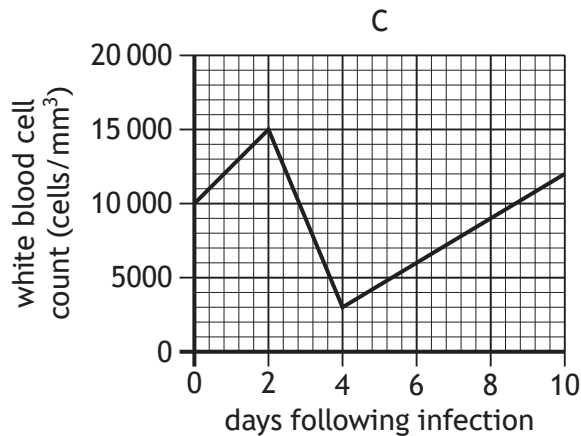
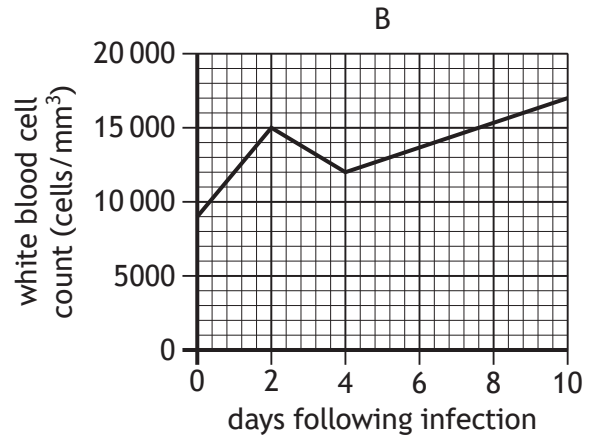
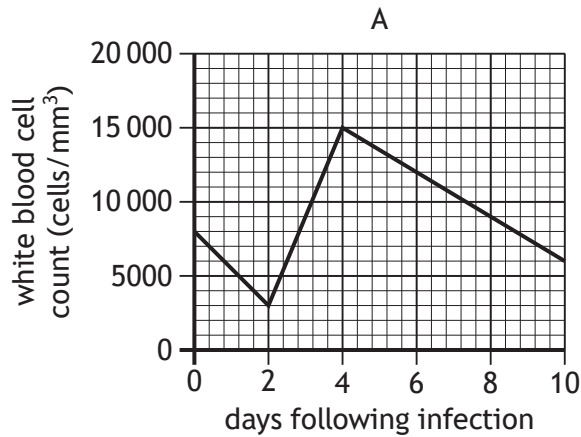

[Turn over

23. The graph shows concentrations of T lymphocytes and HIV in the blood of an individual following infection with HIV.

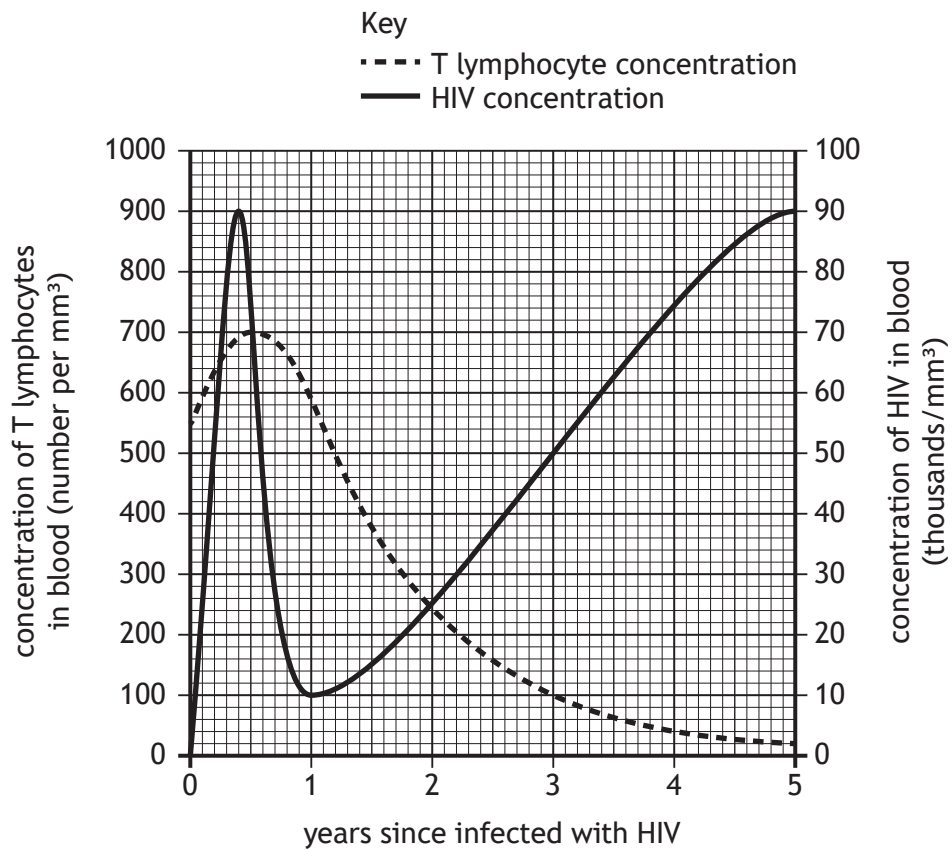

Which row in the table shows the concentration of T lymphocytes and HIV in the blood of the individual, three years since they were infected with HIV?

	Concentration of T lymphocytes in blood (number per mm ³)	Concentration of HIV in blood (thousands/mm ³)
A	100	50
B	500	10
C	100	500
D	10	50

24. A patient was found to have a white blood cell count of 7000 cells/cm³ of blood.

The ratio of phagocytes to lymphocytes was 7:3.

Which row in the table shows the number of phagocytes and lymphocytes in a 10 cm³ sample of this patient's blood?

	Phagocytes	Lymphocytes
A	4900	2100
B	2100	4900
C	49 000	21 000
D	21 000	49 000

25. Influenza is a public health problem every winter.

This is due to changes that occur in the

- A antigens of the virus
- B vaccine given to patients
- C antibodies produced by the body
- D memory cells present in the blood.

[END OF QUESTION PAPER]

SPACE FOR ROUGH WORK

SPACE FOR ROUGH WORK

[BLANK PAGE]

DO NOT WRITE ON THIS PAGE