

GCSE (9–1) Mathematics J560/01 Paper 1 (Foundation Tier) Sample Question Paper

F

Date – Morning/Afternoon

Version 1.2

Time allowed: 1 hour 30 minutes



You may use:

- A scientific or graphical calculator
- Geometrical instruments
- Tracing paper



First name										
Last name										
Centre number										
Candidate number										

INSTRUCTIONS

- Use black ink. You may use an HB pencil for graphs and diagrams.
- Complete the boxes above with your name, centre number and candidate number.
- Answer **all** the questions.
- Read each question carefully before you start to write your answer.
- Where appropriate, your answers should be supported with working. Marks may be given for a correct method even if the answer is incorrect.
- Write your answer to each question in the space provided.
- Additional paper may be used if required but you must clearly show your candidate number, centre number and question number(s).
- Do **not** write in the bar codes.

INFORMATION

- The total mark for this paper is **100**.
- The marks for each question are shown in brackets [].
- Use the π button on your calculator or take π to be 3.142 unless the question says otherwise.
- This document consists of **20** pages.

Answer **all** the questions

- 1 (a) Write 40 : 2000 as a ratio in its simplest form.

(a) : [2]

- (b) Two people share £350 in the ratio 1 : 6.
Calculate each share.

(b) £ £ [2]

- (c) Find 20% of 450.

(c) [2]

- 2 Write these in order, smallest first.

0.34 $\frac{1}{3}$ 3.5%

..... [2]
smallest

- 3 Colin drinks $\frac{3}{8}$ of a litre of milk each day.

Milk costs 89p for a 2-litre carton and 49p for a 1-litre carton.

What is the smallest amount that Colin would have to spend to buy milk for one week?
Show your working.

£ [3]

- 4 An unbiased spinner is shown below.

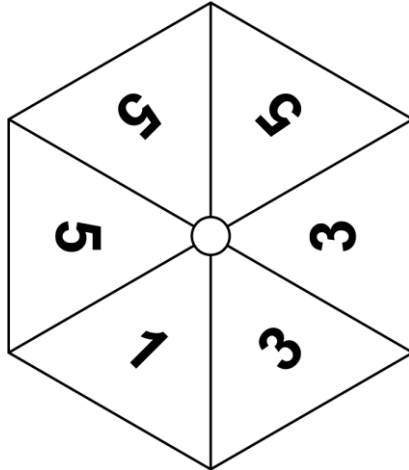

- (a) Write a number to make each sentence true.

(i) It is **evens** that the spinner will land on number [1]

(ii) There is a probability of $\frac{1}{6}$ that the spinner will land on number [1]

(iii) It is **impossible** that the spinner will land on number [1]

- (b) The spinner below has the following properties.

- There are eight equal sections, each showing one number.
- There are three different numbers on the spinner.
- The probability of the spinner landing on an even number is greater than the probability of it landing on an odd number.
- It is more likely that the spinner will land on a 6 than either of the other numbers.

Complete the spinner to show one possible arrangement of numbers.

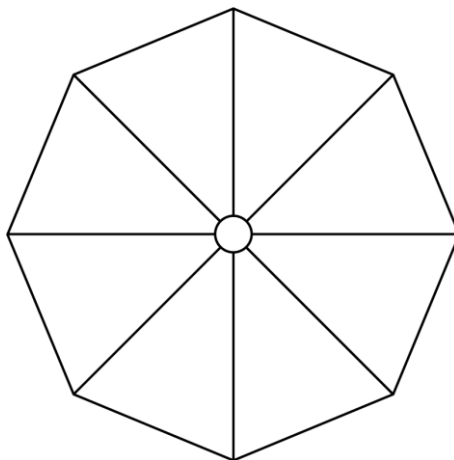

[3]

5 This shape is made from three congruent right-angled triangles.

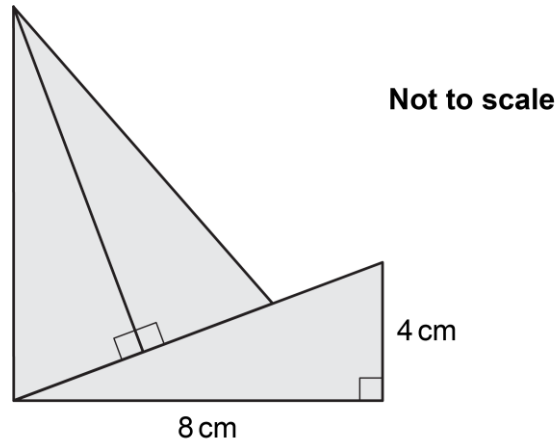

Find the total area of the shape.

..... cm² [3]

6 Here is a Venn diagram.

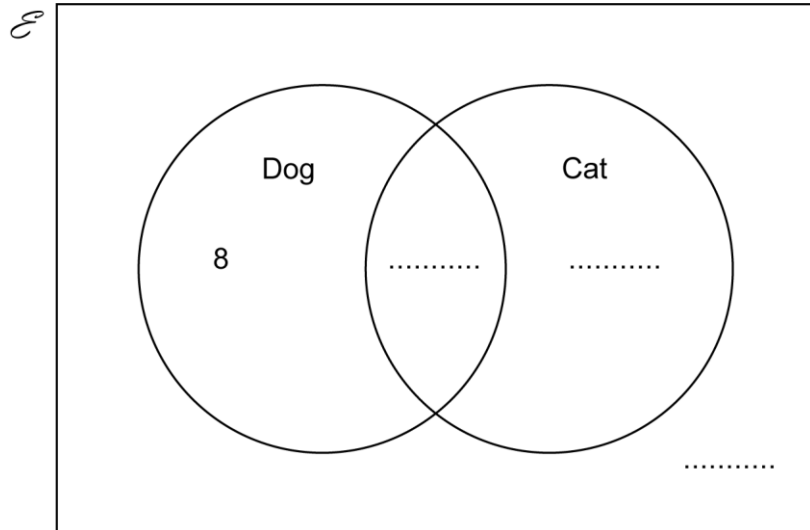

30 students are asked if they have a dog or cat.

- 21 have a dog.
- 16 have a cat.
- 8 have a dog, but not a cat.

Complete the Venn diagram.

[3]

- 7 (a) Write numbers in the boxes below to make the statement true.

$$15 \times 20 = 5 \times \square = 6 \times \square$$

[2]

- (b) Angus thinks of a number.
If he cubes his number and then adds 9, he gets 17.

What number is he thinking of?

(b) [2]

- 8 The diagram shows a triangle.

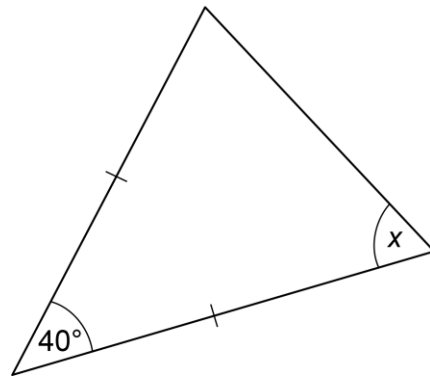



Not to scale

Find the value of x .
Give a reason for each step of your working.

$x = \dots\dots\dots^\circ$ [3]

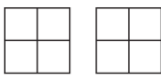
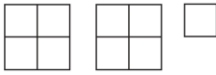
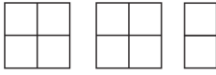
- 9 The pictogram shows how some passengers spent most of their time on a flight.

Reading	
Watching films	
Listening to music	
Playing games	
Other	

Key:  represents 40 people

- (a) How many passengers spent most of their time playing games?

(a) [1]

- (b) How many **more** passengers spent most of their time watching films than reading?

(b) [1]

- (c) There were 360 passengers on the plane.

Complete the pictogram for listening to music.

[3]

10 (a) Insert one of $<$, $>$ or $=$ to make each statement true.

(i) -5 -7 [1]

(ii) 0.09 0.8 [1]

(iii) 6^2 12 [1]

(b) Work out the value of $5^2 \times 10^2$.

(b) [2]

11 Show that $4(a + 3) - 3(a - 2) = a + 18$. [2]

12 Here are the first three patterns in a sequence.

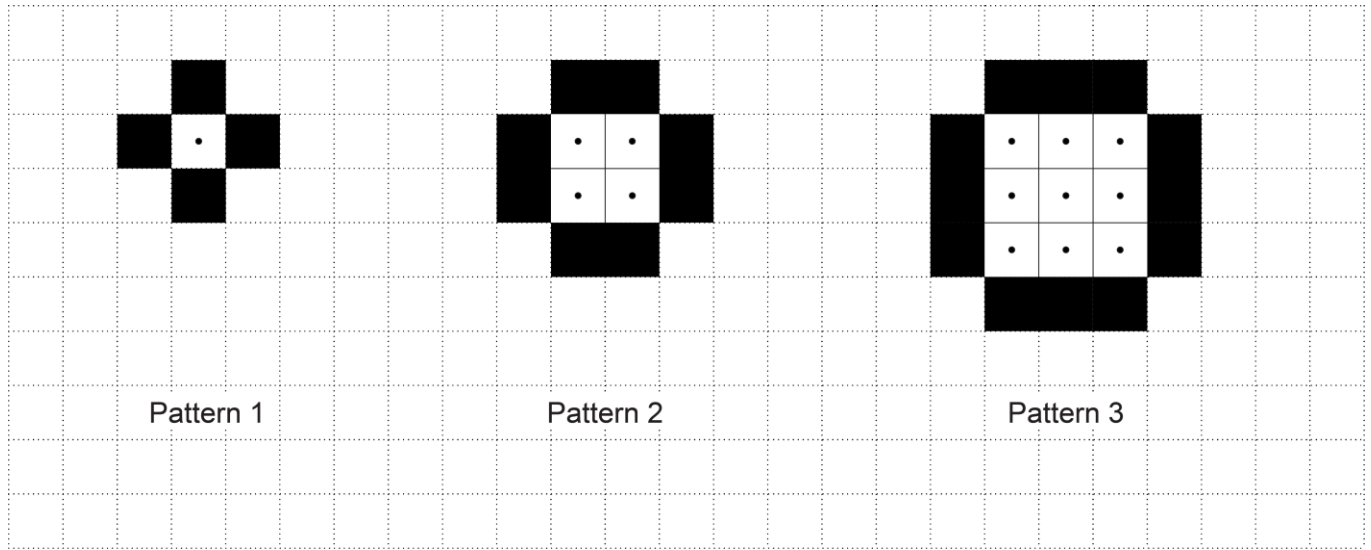

(a) Draw Pattern 4 in this sequence on the grid below.



[2]

(b) Pattern 3 has 9 dotted squares and 12 black squares.

How many **dotted** squares will there be in Pattern 8?

(b) [2]

(c) Write an expression for the number of **black** squares in the n th pattern.

(c) [2]

(d) Sally looks at the patterns.
She says

If the pattern number is odd, the total number of squares will be odd.
If it is even, the total number of squares will be even.

Explain clearly why Sally is right for **all** patterns in the sequence.

.....
.....
.....
.....
..... [6]

- 13 (a) (i) Sketch a graph on the axes below that shows that y is directly proportional to x .

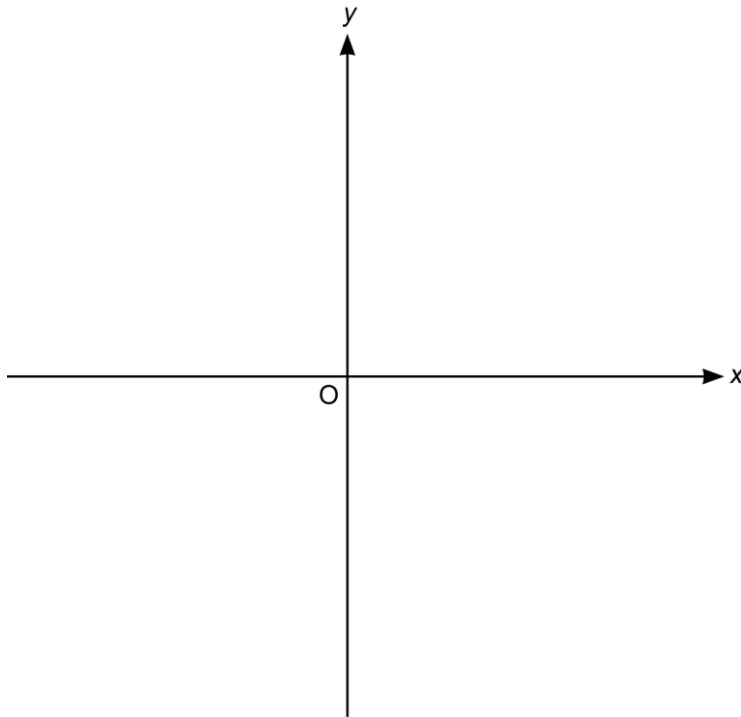

[2]

- (ii) Sketch a graph on the axes below that shows $y = x^3$.

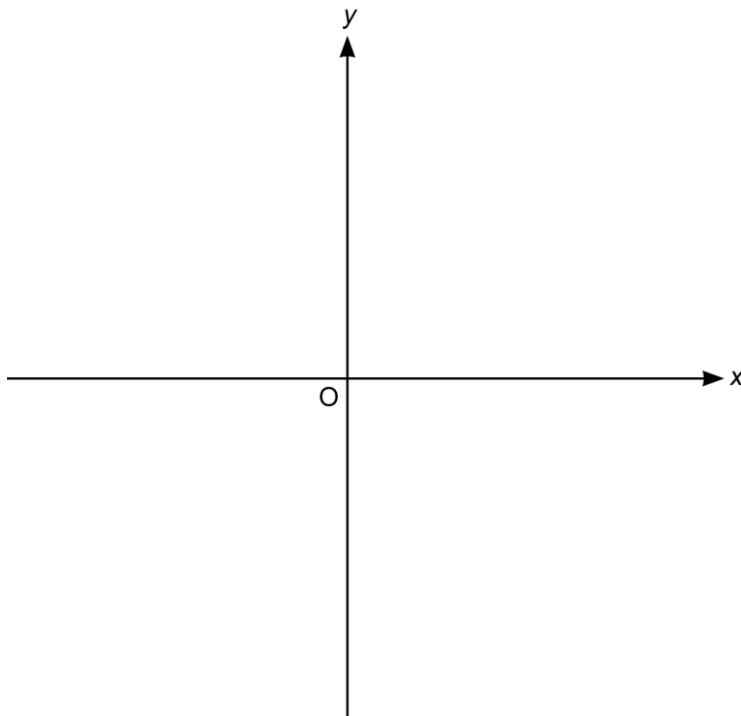

[2]

- (b) It is possible to draw many rectangles that have area 24cm^2 . Here are two of them.

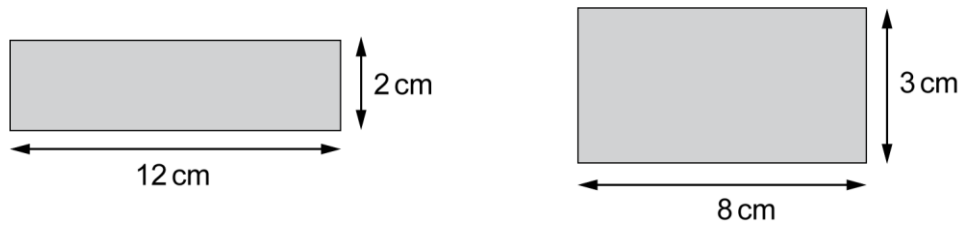

Not to scale

- (i) Plot the dimensions of these two rectangles on the grid below. [1]
- (ii) Complete the graph to show the relationship between length and width for rectangles with area 24cm^2 . [3]

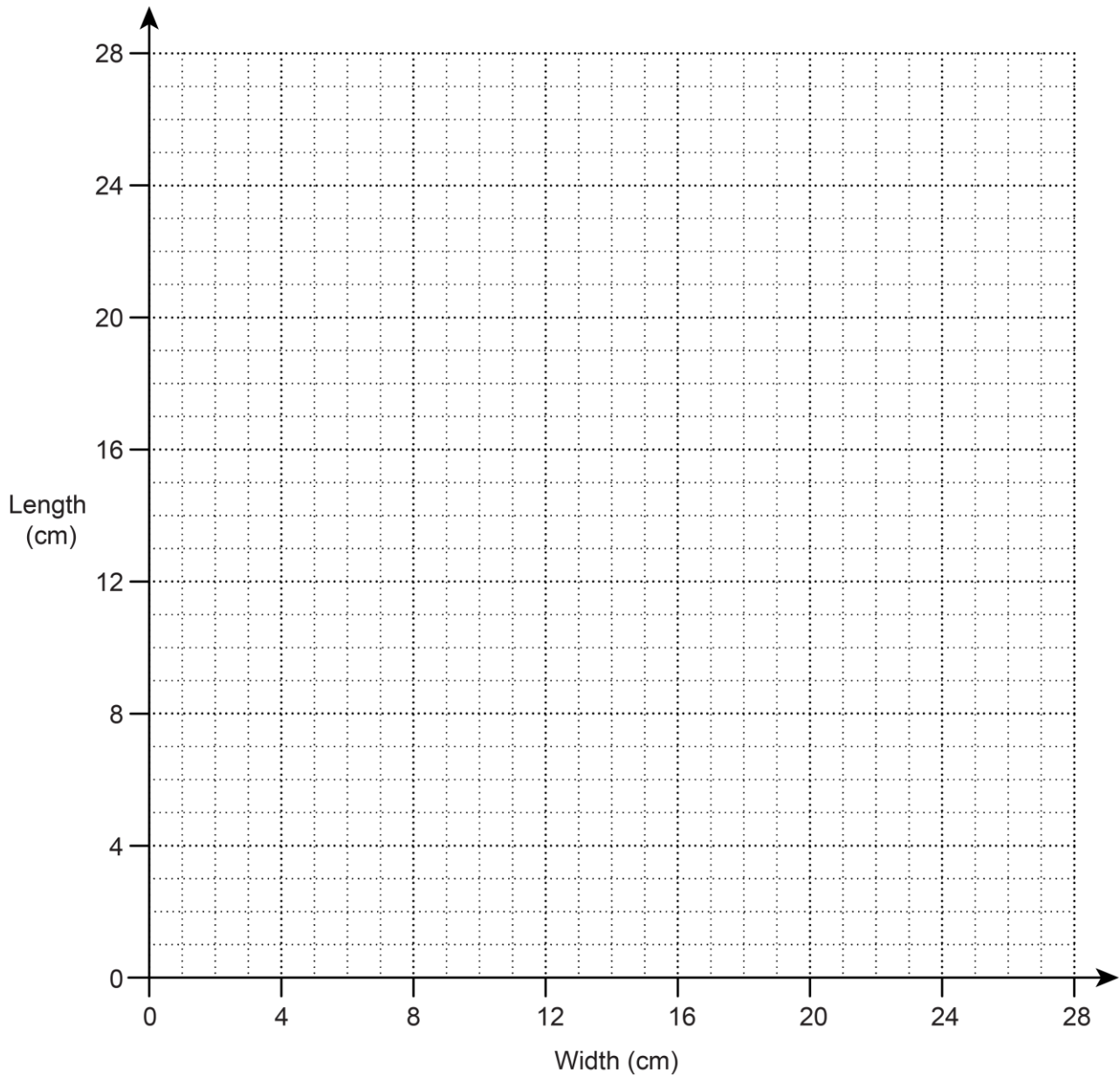

14 The value of a car £ V is given by

$$V = 20\,000 \times 0.9^t$$

where t is the age of the car in complete years.

(a) Write down the value of V when $t = 0$.

(a) £ [1]

(b) What is the value of V when $t = 3$?

(b) £ [2]

(c) After how many complete years will the car's value drop below £10 000?

(c) [2]

15 Kieran, Jermaine and Chris play football.

- Kieran has scored 8 more goals than Chris.
- Jermaine has scored 5 more goals than Kieran.
- Altogether they have scored 72 goals.

How many goals did they each score?
You must show your working.

Kieran

Jermaine

Chris

[5]

- 16 Otis keeps bees in two beehives. They are marked P and Q in the scale drawing below.

Scale: 1 cm represents 50 metres

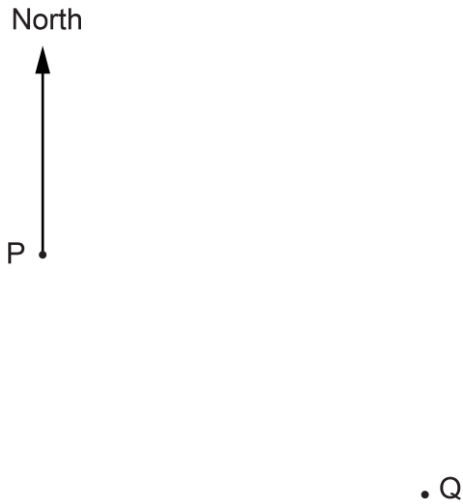

- (a) If Otis walks at about 2 m/s, estimate how long it takes him to walk from beehive P to beehive Q.

(a) [3]

(b) Bees can indicate to other bees where flowers are.

A bee indicates that there are flowers

- on a bearing of 055° from P
- at a distance of 400 m from P.

On the scale drawing, show the point where the flowers are.
Label this point F.

[2]

(c) Otis plants some fruit trees, which are

- the same distance from P and from Q
- 200 m or less from P.

Indicate on the scale drawing where Otis plants the trees.
You must show all your construction lines.

[4]

17 Six equations are shown below, each labelled with a letter.

A
$y = -6x$

B
$x = \frac{1}{6}y$

C
$y = \frac{-3}{x}$

D
$x = \frac{6}{y}$

E
$y = 6x$

F
$y = \frac{2}{x} + 2$

Choose the correct letters to make each statement true.

(a) Equation **B** and equation are equivalent. [1]

(b) Equation and equation each show x is inversely proportional to y . [2]

18 Jo went for a bike ride one evening.

She travelled x kilometres in 5 hours.

Show that her average speed can be written as $\frac{x}{18}$ m/s. [4]

- 19 Peter makes a large amount of pink paint by mixing red and white paint in the ratio 2 : 3.

Red paint costs £80 per 10 litres.

White paint costs £5 per 10 litres.

Peter sells his pink paint in 10-litre tins for £60 per tin.

Calculate how much **profit** he makes for each tin he sells.
You must show your working.

£ [5]

- 20 The diagram shows a right-angled triangle.

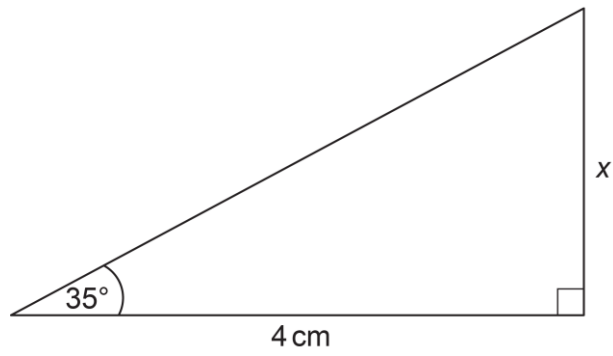

Not to scale

Calculate x .

..... cm [3]

- 21 Louise travels to work and home again by train.
The probability that her train to work is late is 0.7.
The probability that her train home is late is 0.4.

What is the probability that **at least** one of her trains is late?

..... [4]

Summary of updates

Date	Version	Details
February 2024	1.1	Insertion of “You must show your working” to questions 15 and 19
March 2025	1.2	Amendment to wording of section 13 of the mark scheme

Copyright Information

OCR is committed to seeking permission to reproduce all third-party content that it uses in the assessment materials. OCR has attempted to identify and contact all copyright holders whose work is used in this paper. To avoid the issue of disclosure of answer-related information to candidates, all copyright acknowledgements are reproduced in the OCR Copyright Acknowledgements Booklet. This is produced for each series of examinations and is freely available to download from our public website (www.ocr.org.uk) after the live examination series.

If OCR has unwittingly failed to correctly acknowledge or clear any third-party content in this assessment material, OCR will be happy to correct its mistake at the earliest possible opportunity.

For queries or further information please contact OCR, The Triangle Building, Shaftesbury Road, Cambridge CB2 8EA.

OCR is part of the Cambridge Assessment Group; Cambridge Assessment is the brand name of University of Cambridge Local Examinations Syndicate (UCLES), which is itself a department of the University of Cambridge.

OCR

Oxford Cambridge and RSA

F

Date – Morning/Afternoon

GCSE (9–1) Mathematics

J560/01 Paper 1 (Foundation Tier)

SAMPLE MARK SCHEME

Duration: 1 hour 30 minutes

MAXIMUM MARK 100

This document consists of 15 pages

Subject-Specific Marking Instructions

1. **M** marks are for using a correct method and are not lost for purely numerical errors.
A marks are for an accurate answer and depend on preceding **M** (method) marks. Therefore **M0 A1** cannot be awarded.
B marks are independent of **M** (method) marks and are for a correct final answer, a partially correct answer, or a correct intermediate stage.
SC marks are for special cases that are worthy of some credit.
2. Unless the answer and marks columns of the mark scheme specify **M** and **A** marks etc, or the mark scheme is 'banded', then if the correct answer is clearly given and is not from wrong working **full marks** should be awarded.

Do not award the marks if the answer was obtained from an incorrect method, i.e. incorrect working is seen and the correct answer clearly follows from it.

3. Where follow through (**FT**) is indicated in the mark scheme, marks can be awarded where the candidate's work follows correctly from a previous answer whether or not it was correct.

Figures or expressions that are being followed through are sometimes encompassed by single quotation marks after the word *their* for clarity, e.g. FT $180 \times (\textit{their} '37' + 16)$, or FT $300 - \sqrt{(\textit{their} '5^2 + 7^2')}$. Answers to part questions which are being followed through are indicated by e.g. FT $3 \times \textit{their} (a)$.

For questions with FT available you must ensure that you refer back to the relevant previous answer. You may find it easier to mark these questions candidate by candidate rather than question by question.

4. Where dependent (**dep**) marks are indicated in the mark scheme, you must check that the candidate has met all the criteria specified for the mark to be awarded.
5. The following abbreviations are commonly found in GCSE Mathematics mark schemes.
 - **figs 237**, for example, means any answer with only these digits. You should ignore leading or trailing zeros and any decimal point e.g. 237000, 2.37, 2.370, 0.00237 would be acceptable but 23070 or 2374 would not.
 - **isw** means **ignore subsequent working** after correct answer obtained and applies as a default.
 - **nfw** means **not from wrong working**.
 - **oe** means **or equivalent**.
 - **rot** means **rounded or truncated**.
 - **seen** means that you should award the mark if that number/expression is seen anywhere in the answer space, including the answer line, even if it is not in the method leading to the final answer
 - **soi** means **seen or implied**.

6. In questions with no final answer line, make no deductions for wrong work after an acceptable answer (ie **isw**) unless the mark scheme says otherwise, indicated by the instruction 'mark final answer'.
7. In questions with a final answer line following working space:
- (i) If the correct answer is seen in the body of working and the answer given on the answer line is a clear transcription error allow full marks unless the mark scheme says 'mark final answer'. Place the annotation ✓ next to the correct answer.
 - (ii) If the correct answer is seen in the body of working but the answer line is blank, allow full marks. Place the annotation ✓ next to the correct answer.
 - (iii) If the correct answer is seen in the body of working but a completely different answer is seen on the answer line, then accuracy marks for the answer are lost. Method marks could still be awarded. Use the M0, M1, M2 annotations as appropriate and place the annotation ✕ next to the wrong answer.
8. In questions with a final answer line:
- (i) If one answer is provided on the answer line, mark the method that leads to that answer.
 - (ii) If more than one answer is provided on the answer line and there is a single method provided, award method marks only.
 - (iii) If more than one answer is provided on the answer line and there is more than one method provided, award zero marks for the question unless the candidate has clearly indicated which method is to be marked.
9. In questions with no final answer line:
- (i) If a single response is provided, mark as usual.
 - (ii) If more than one response is provided, award zero marks for the question unless the candidate has clearly indicated which response is to be marked.
10. When the data of a question is consistently misread in such a way as not to alter the nature or difficulty of the question, please follow the candidate's work and allow follow through for **A** and **B** marks. Deduct 1 mark from any **A** or **B** marks earned and record this by using the MR annotation. **M** marks are not deducted for misreads.

11. Unless the question asks for an answer to a specific degree of accuracy, always mark at the greatest number of significant figures even if this is rounded or truncated on the answer line. For example, an answer in the mark scheme is 15.75, which is seen in the working. The candidate then rounds or truncates this to 15.8, 15 or 16 on the answer line. Allow full marks for the 15.75.
12. Ranges of answers given in the mark scheme are always inclusive.
13. For methods not provided for in the mark scheme (including visual representations such as bar models, ratio tables, etc) give as far as possible equivalent marks for equivalent work. If in doubt, consult your Team Leader.
14. Anything in the mark scheme which is in square brackets [...] is not required for the mark to be earned, but if present it must be correct.

Question		Answer	Marks	Part marks and guidance	
1	(a)	1 : 50	2 2 A01.3a	M1 shows a partial simplification	e.g. 4 : 200
	(b)	50 300	2 2 A01.3a	M1 for $350 \div (1 + 6)$	
	(c)	90	2 2 A01.3a	M1 for $10\% = 45$ soi or M1 for 450×0.2	
2		3.5%, $\frac{1}{3}$, 0.34	2 2 A01.3a	B1 for $\frac{1}{3} = 0.33\dots$ or 33. ...% or B1 for $0.34 = 34\%$ or B1 for changing 3.5% to 0.035 or SC1 for $\frac{1}{3}$, 0.34, 3.5%	Accept correct order with equivalent values
3		£1.38 with working shown	3 1 A01.3a 1 A03.1d 1 A03.3	M1 for $7 \times \frac{3}{8}$ M1 for $89p + 49p$ or $3 \times 49p$ or $2 \times 49p > 89p$ OR B1 for £1.38 without working	Condone 138p

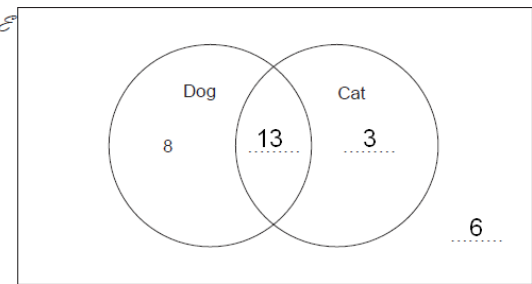
Question			Answer	Marks	Part marks and guidance
4	(a)	(i)	5	1 1 AO1.1	
		(ii)	1	1 1 AO1.1	
		(iii)	Any number apart from 1, 3 or 5	1 1 AO1.1	
	(b)		Three different numbers only 6 appears most More even numbers than odd	3 3 AO2.1a	B1 for each of the three properties
5			48 (cm ²)	3 1 AO1.3a 2 AO3.1b	M1 for $\frac{1}{2} \times 8 \times 4 = 16$ M1 for <i>their</i> '16' $\times 3$
6				3 3 AO1.3b	B1 for 13 in 'intersection' B1 for (16 – <i>their</i> '13') in 'Cat' B1 for sum of 8 + <i>their</i> three numbers = 30
7	(a)		60 50	2 1 AO1.3a 1 AO3.1a	B1 for each
	(b)		2	2 1 AO1.3a 1 AO3.1a	M1 for 8 seen

Question			Answer	Marks	Part marks and guidance
8			70 The triangle is isosceles so the missing angle is x (may be on diagram) oe Angles in a triangle sum to 180° oe (may be indicated by summing of angles to 180 oe)	3 1 AO1.3a 1 AO2.4a 1 AO3.1b	B1 for each
9	(a)		100	1 1 AO2.1a	
	(b)		10	1 1 AO2.1a	
	(c)		One and a quarter boxes drawn	3 1 AO1.3a 1 AO2.3b 1 AO3.1c	M2 for 50 or M1 for 310 or M1 FT from subtraction
10	(a)	(i)	>	1 1 AO1.2	
		(ii)	<	1 1 AO1.2	
		(iii)	>	1 1 AO1.2	
	(b)		2500 oe	2 1 AO1.2 1 AO1.3a	M1 for 25 or 100
11			Correct reasoning	2 1 AO1.3a 1 AO2.2	M1 for $4a + 12 - 3a \pm 6$

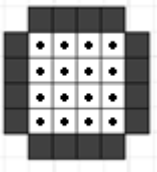
Question		Answer	Marks	Part marks and guidance
12	(a)		<p>2</p> <p>1 A02.1a 1 A02.3b</p>	<p>B1 for 4×4 dotted squares correct</p> <p>B1 for 4 blocks of 4 black squares correct</p>
	(b)	64	<p>2</p> <p>1 A01.3a 1 A02.1a</p>	<p>M1 for 8×8 or 8^2 or 8 squared</p>
	(c)	$4n$	<p>2</p> <p>1 A01.3a 1 A02.3a</p>	<p>M1 for 4 8 12 seen</p>
	(d)	<p>Number of blacks is always even oe and reason</p> <p>Number of dots alternates between odd and even oe and reason</p> <p>even + even = even</p> <p>odd + even = odd</p>	<p>B1</p> <p>B1</p> <p>B1</p> <p>B1</p> <p>B1</p> <p>B1</p> <p>2 A02.2 4 A02.4b</p>	<p>Accept 4 times table or 4 is even</p> <p>Accept any reason that has explanatory value e.g. $\text{odd}^2 = \text{odd}$</p> <p>If 0 scored, instead award B1 shows true for patterns 1, 2 and 3 B1 shows true for at least two more patterns</p>

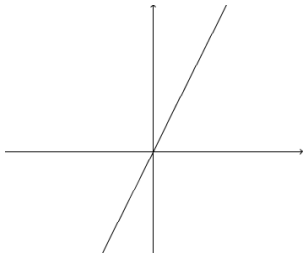
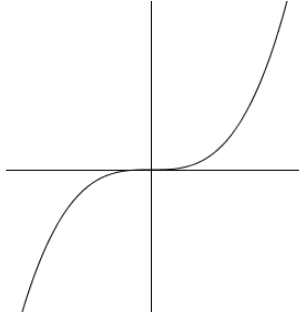
Question			Answer	Marks	Part marks and guidance
13	(a)	(i)	Any straight line through the origin e.g. 	2 1 AO1.1 1 AO2.3b	B1 for a straight line
		(ii)		2 1 AO1.1 1 AO2.3b	B1 for a cubic with two turning points
	(b)	(i)	At least one point plotted correctly	1 1 AO2.3b	

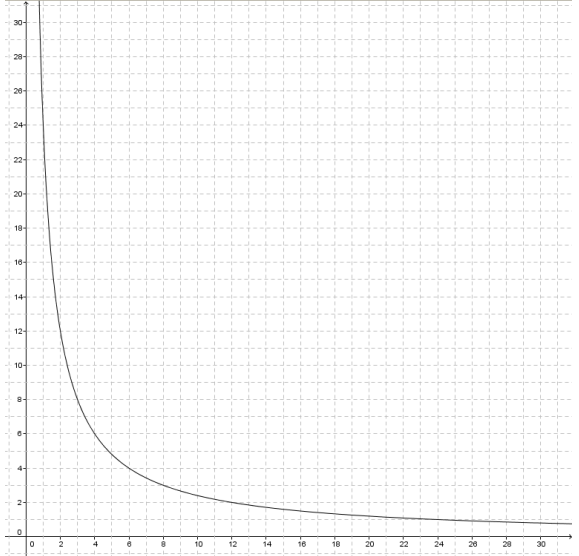
Question		Answer	Marks	Part marks and guidance	
	(ii)		3 1 A02.3b 1 A03.1b 1 A03.2	B2 for at least 5 points correctly plotted OR B1 for at least 3 points correctly plotted AND B1 for <u>curve</u> drawn through <i>their</i> points	
14	(a)	£20 000	1 1 A01.3a		
	(b)	£14 580 or £14 600	2 2 A01.3a	M1 for $20\,000 \times 0.9^3$	
	(c)	7 years	2 1 A01.3a 1 A03.1c	M1 for 2 trials shown	

15			<p>25 30 17 with correct working</p>	<p>5 2 AO1.3a 2 AO3.1d 1 AO3.3</p>	<p>M1 for $x - 8 + x + x + 5 = 72$ M1FT for $3x - 3 = 72$ M1FT for $3x = 75$ implied by $x = 25$</p> <p>AND</p> <p>M1 for substituting <i>their</i> 25 into $x - 8$ and $x + 5$</p> <p><u>Alternative method using trials</u> M3 for a correctly evaluated trial of $x - 8 + x + x + 5$ with $x = 25$ Or M2 for at least two complete correct evaluations of $x - 8 + x + x + 5$ Or M1 for at least one complete correct evaluation of $x - 8 + x + x + 5$</p> <p>AND</p> <p>M1 for substituting <i>their</i> 25 into $x - 8$ and $x + 5$</p> <p>If 0 or 1 scored, instead award SC2 for 25, 30, 17 with no working or insufficient working</p> <p>If 0 scored, instead award SC1 for $x = 25$ with no working or insufficient working</p>	<p>“Correct working” requires evidence of at least M1M1M1 or M3</p> <p>Methods shown use Kieran as x; apply similar schemes if using Jermaine or Chris as the subject</p> <p>Note: $x = 25$ scores M1M1M1 if there is some supporting work but on its own scores SC1</p>
----	--	--	--	--	---	--

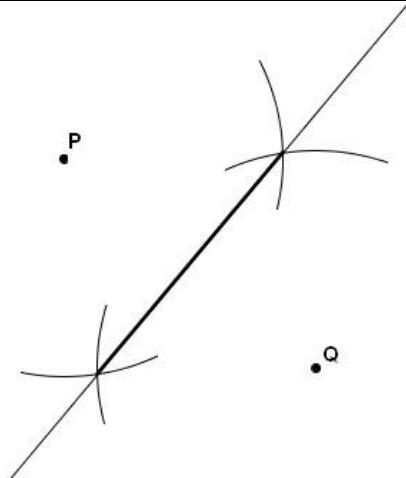
Question		Answer	Marks	Part marks and guidance	
16	(a)	140 – 160 (s)	3 1 A01.3a 1 A03.1d 1 A03.2	B1 for 300 ± 20 (m) M1 for $\frac{\text{their '300'}}{2}$	
	(b)	Correct location for F	2 1 A01.3a 1 A03.1d	B1 for angle $55^\circ \pm 2^\circ$ B1 for distance $8 \text{ cm} \pm 0.2$	
	(c)		4 1 A01.3b 1 A02.3b 2 A03.1d	B1 for perpendicular bisector of PQ drawn $\pm 2^\circ$ B1 for arcs seen B1 arc centre P, radius 4 ± 0.2 cm B1 for correct line segment marked FT <i>their</i> constructions	Arcs must be fit for purpose May be the same arcs as used for perpendicular bisector as shown
17	(a)	E	1 1 A01.3a		
	(b)	C and D	2 2 A01.3a	B1 for each	

Question	Answer	Marks	Part marks and guidance
18	$\text{Average speed} = \frac{\text{Distance}}{\text{Time}} = \frac{x}{5} \text{ km/h}$ $= \frac{1000x}{60^2 \times 5} \text{ m/s}$ $= \frac{1000x}{18000} \text{ m/s oe}$ $= \frac{x}{18} \text{ m/s}$	<p>4 2 AO1.3a 2 AO2.2</p>	<p>B1 for $x \text{ km} = 1000xm$</p> <p>B1 for 5 hours = $60^2 \times 55 \text{ s}$</p> <p>B1 for working to given answer without intermediate expression or statement of formula</p>
19	25 with correct working	<p>5 2 AO1.3b 3 AO3.1d</p>	<p>“Correct working” requires evidence of at least M1M1</p> <p><u>Alternative method</u> M1 for $2 : 3 = 20 \text{ litres red} : 30 \text{ litres white}$ M1 for $2 \times \text{£}80 + 3 \times \text{£}5 = \text{£}175$ M1 for $\frac{\text{their } 175}{5} = 35$ M1 for $60 - \text{their } 35$</p> <p>M1 for red costs £8 per litre or for white costs £0.50 per litre</p> <p>M1 for cost of one 10-litre can is $\text{their } 4 \times \text{their } 8 + \text{their } 6 \times \text{their } 0.5$</p> <p>M1 for $60 - \text{their } 35$</p> <p>If 0 or 1 scored, instead award SC2 for answer 25 with no working or insufficient working</p>
20	2.8(0...)	<p>3 1 AO1.1 2 AO1.3a</p>	<p>B1 for $\tan \theta = \frac{\text{opp}}{\text{adj}}$</p> <p>M1 for $4 \times \tan 35$</p>

Question			Answer	Marks	Part marks and guidance
21			0.82 oe	4 1 AO1.3a 3 AO3.1d	M3 for $0.7 \times 0.4 + 0.7 \times 0.6 + 0.3 \times 0.4$ or $1 - 0.18$ Or M2 for two correct products Or M1 for one correct product or 0.3 and 0.6 seen (may be on a tree diagram or equivalent)

**Assessment Objectives (AO)
Grid**

Question	AO1	AO2	AO3	Total
1(a)	2			2
1(b)	2			2
1(c)	2			2
2	2			2
3	1		2	3
4(a)(i)	1			1
4(a)(ii)	1			1
4(a)(iii)	1			1
4(b)		3		3
5	1		2	3
6	3			3
7(a)	1		1	2
7(b)	1		1	2
8	1	1	1	3
9(a)		1		1
9(b)		1		1
9(c)	1	1	1	3
10(a)(i)	1			1
10(a)(ii)	1			1
10(a)(iii)	1			1
10(b)	2			2
11	1	1		2
12(a)		2		2
12(b)	1	1		2
12(c)	1	1		2
12d		6		6
13(a)(i)	1	1		2
13(a)(ii)	1	1		2
13(b)(i)		1		1
13(b)(ii)		1	2	3
14(a)	1			1
14(b)	2			2
14(c)	1		1	2
15	2		3	5
16(a)	1		2	3
16(b)	1		1	2
16(c)	1	1	2	4
17(a)	1			1
17(b)	2			2
18	2	2		4
19	2		3	5
20	3			3
21	1		3	4
Totals	50	25	25	100

GCSE (9–1) Mathematics J560/02 Paper 2 (Foundation Tier) Sample Question Paper

F

Date – Morning/Afternoon

Version 1.2

Time allowed: 1 hour 30 minutes

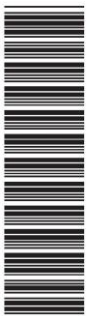

You may use:

- Geometrical instruments
- Tracing paper

Do not use:

- A calculator



First name										
Last name										
Centre number						Candidate number				

INSTRUCTIONS

- Use black ink. You may use an HB pencil for graphs and diagrams.
- Complete the boxes above with your name, centre number and candidate number.
- Answer **all** the questions.
- Read each question carefully before you start to write your answer.
- Where appropriate, your answers should be supported with working. Marks may be given for a correct method even if the answer is incorrect.
- Write your answer to each question in the space provided.
- Additional paper may be used if required but you must clearly show your candidate number, centre number and question number(s).
- Do **not** write in the bar codes.

INFORMATION

- The total mark for this paper is **100**.
- The marks for each question are shown in brackets [].
- This document consists of **20** pages.

Answer **all** the questions

- 1 (a) Work out.

$$4 \times 2 - 1$$

(a) [1]

- (b) Find $\frac{1}{4}$ of 16.

(b) [1]

- 2 A tin contains four different types of sweet.
A sweet is taken from the tin at random.
The table below shows some of the probabilities of taking each type of sweet.

Sweet	Toffee	Fudge	Jelly	Mint
Probability	0.4	0.2		0.3

- (a) Complete the table. [2]

- (b) What is the probability that a toffee or a mint is taken from the tin?

(b) [2]

3 Peter says

The sum of an odd number and an even number is even.

The example $3 + 4 = 7$ shows that Peter is **not** correct.

Write an example to show that each of these statements is **not** correct.

(a) The sum of two prime numbers is always odd.

..... [1]

(b) Squaring a whole number always results in an even number.

..... [1]

4 Charlie, Mo and Andrzej share a flat.

- Charlie pays 25% of the rent.
- Mo pays $\frac{1}{2}$ of the rent.
- Andrzej pays £450.

How much do they pay altogether for the rent?

£ [4]

- 5 The table below shows the number of tonnes of rice produced in a year in five countries.

Country	Rice produced (tonnes)
China	1.43×10^8
India	9.9×10^7
Vietnam	2.71×10^7
Thailand	2.05×10^7
Brazil	7.82×10^6

- (a) Which country produced the most rice?

(a) [1]

- (b) Write 2.71×10^7 as an ordinary number.

(b) [1]

- (c) One tonne is equal to 1000 kilograms.

Change 7.82×10^6 tonnes to kilograms.
Give your answer in standard form.

(c) kg [2]

- (d) How many **more** tonnes of rice did India produce than Thailand?
Give your answer in standard form.

(d) tonnes [2]

- 6 (a) A square has an area of 100 cm^2 .
Find its perimeter.

(a) cm [2]

- (b) The area of the parallelogram is **three** times the area of the triangle.

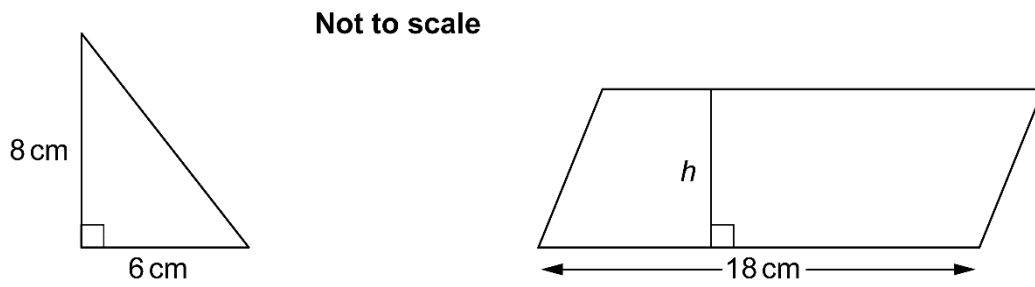

Show that the perpendicular height h of the parallelogram is 4 cm.

[4]

7 Here are six numbers.

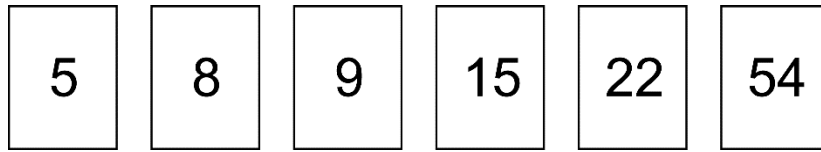

From these numbers, find a number that is

(a) a multiple of two and a multiple of three,

(a) [1]

(b) a factor of 30 and a factor of 40.

(b) [2]

8 (a) The product of three numbers is 312.
Two of the numbers are 3 and 13.

What is the third number?

(a) [3]

(b) Find **three different** numbers that are each

- a prime number
- two less than a square number.

(b) [3]

9 These prisms have different shapes as end faces.

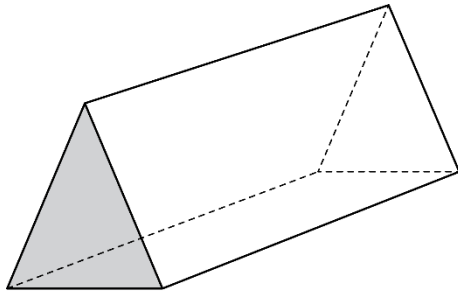

Triangle

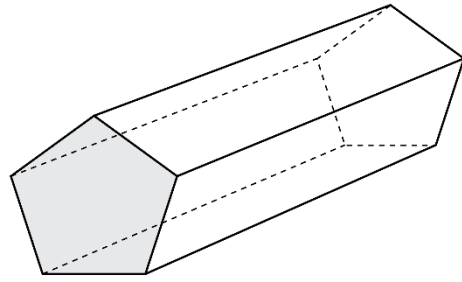

Pentagon

(a) Complete this table.

Shape of end face	Number of faces	Number of edges	Number of vertices
Triangle (3 sides)	5	9	6
Rectangle (4 sides)	8
Pentagon (5 sides)	15	10
Hexagon (6 sides)	8	18

[2]

(b) How many edges and vertices does a prism with a 100-sided end face have?

(b) edges

vertices

[2]

(c) F is the number of faces in a prism.
 N is the number of sides of its end face.

Write down a formula connecting F and N .

(c) [2]

- 10 The graph shows the number of ice creams sold in a shop each day against the temperature at midday that day.

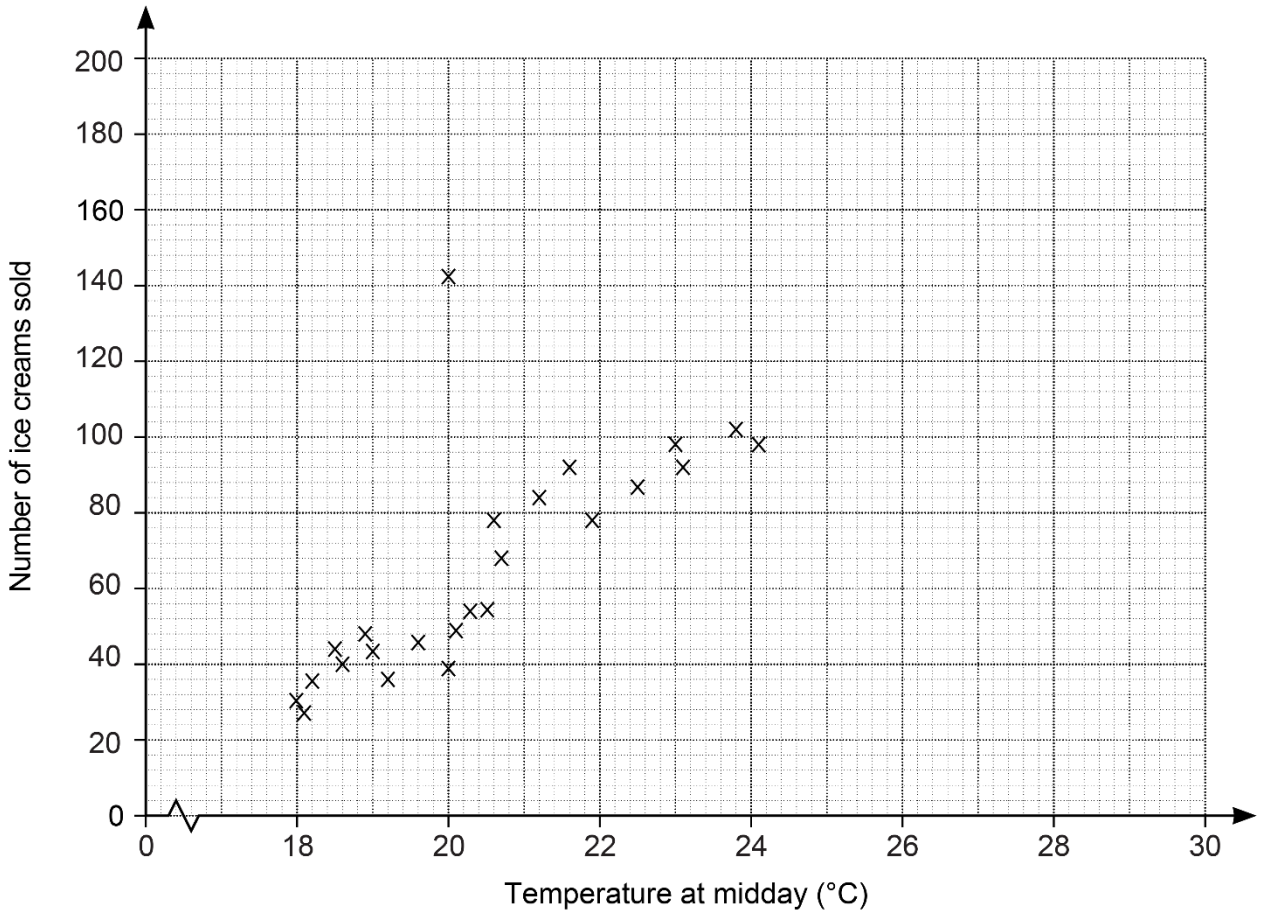

- (a) (i) Describe the relationship between the temperature at midday and the number of ice creams sold.
 [1]
- (ii) One data point is an outlier.
 Give a reason why this does not fit the rest of the data.
 [1]

(b) Use the scatter graph to predict the number of ice creams sold on a day when the temperature at midday was

(i) 22°C

(b)(i) [1]

(ii) 28°C.

(ii) [1]

(iii) Explain which of these two predictions is more reliable.

.....
.....
..... [2]

(c) A newspaper headline reads

High temperatures make more people buy ice cream!

Does the graph above prove this claim?

Give a reason for your decision.

.....
.....
..... [2]

- 11 (a) A shop sold goods worth a total of £50 000 in January.
The value of goods sold in February was 10% lower than in January.

Calculate the value of goods sold in February.

(a) £ [2]

- (b) Each month, the value of goods sold continued to be 10% lower than the previous month.
When the value of goods sold was less than £35 000, the shop closed at the end of that month.

Show that the store closed at the end of May. [3]

- (c) The store reopens under new management and sells goods worth £100 000 in the first month.
- The value of goods sold in the second month is 20% more than the first month.
 - The value of goods sold in the third month is 10% less than the second month.

Find the percentage increase in the total value of goods sold from the first month to the third month. You must show your working.

(c)% [5]

- 12 (a) Solve.

$$5x = 2x + 18$$

(a) $x =$ [2]

- (b) Solve by factorising.

$$x^2 + 8x + 15 = 0$$

(b) $x =$ [3]

- 13** Eva's camera takes photos with width and height in the ratio 3 : 2.
Photos can be printed in the following sizes.

20 cm by 16 cm

14 cm by 10 cm

24 cm by 16 cm

12 cm by 8 cm

Eva says

Only two of these sizes have the same ratio as my photos!

- (a)** Which sizes have the same ratio as her photos?

..... [2]

- (b)** Eva has a display board measuring 45 cm by 60 cm.
She wants to display postcards, each measuring 9 cm by 6 cm.

If no postcards overlap, find the maximum number of postcards she can display on the board.

(b) [3]

14 (a) Here is a coordinate grid.

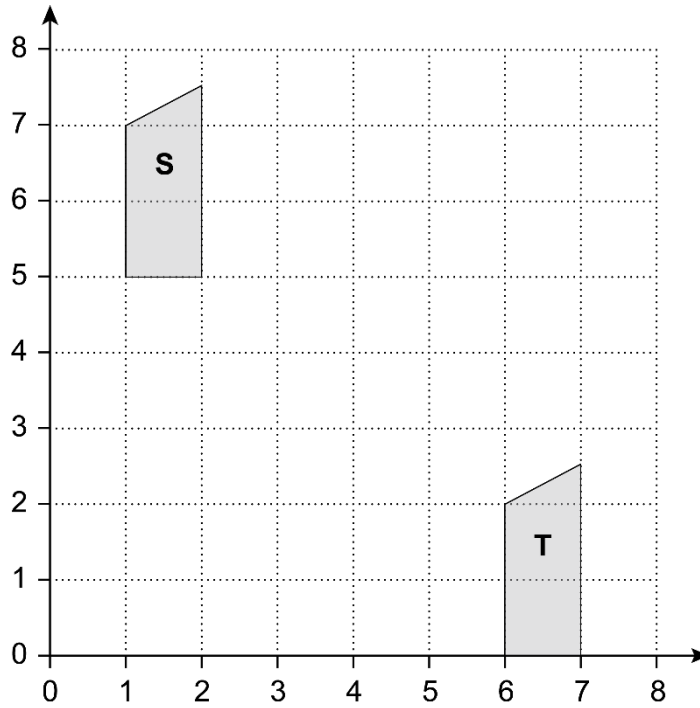

Shape S is translated to Shape T using vector $\begin{pmatrix} p \\ q \end{pmatrix}$.

Write down the values of p and q .

(a) $p = \dots\dots\dots$
 $q = \dots\dots\dots$ [2]

(b) Vectors **a**, **b**, **c**, **d** and **e** are drawn on an isometric grid.

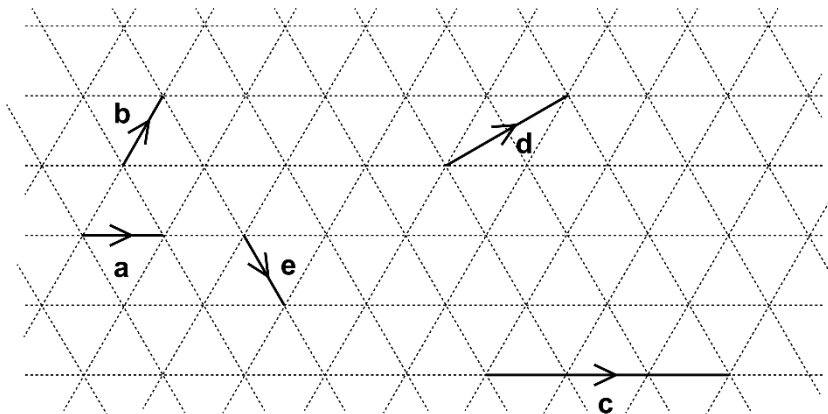

Write each of the vectors **c**, **d** and **e** in terms of **a** and/or **b**.

c = $\dots\dots\dots$
d = $\dots\dots\dots$
e = $\dots\dots\dots$

[3]

15 Sam and two friends put letters in envelopes on Monday.
The three of them take two hours to put 600 letters in envelopes.

(a) On Tuesday Sam has three friends helping.

Working at the same rate, how many letters should the **four** of them be able to put in envelopes in two hours?

(a) [2]

(b) Working at the same rate, how much longer would it take **four** people to put 1000 letters in envelopes than it would take **five** people?

(b) [4]

(c) Sam says

It took two hours for three people to put 600 letters in envelopes.
If I assume they work all day, then in one day three people will put 7200 letters in envelopes because $600 \times 12 = 7200$.

Why is Sam's assumption not reasonable?
What effect has Sam's assumption had on her answer?

.....
..... [2]

16 Abi, Ben and Carl each drop a number of identical drawing pins, and count how many land with the pin upwards. The table shows some of their results.

	Number of pins dropped	Number landing 'pin up'
Abi	10	4
Ben	30	9
Carl	100	35

(a) Abi says

As a drawing pin can only land with its pin up or with its pin down, the probability of a drawing pin landing 'pin up' is $\frac{1}{2}$.

Criticise her statement.

.....
 [1]

(b) Carl's results give the best estimate of the probability of a drawing pin landing 'pin up'. Explain why.

.....
 [1]

(c) Two pins are dropped.

Estimate the probability that both pins land 'pin up'.

(c) [2]

17 In this row of boxes, you start with 5 and 7.

5	7			
---	---	--	--	--

You add 5 and 7 to get 12 to go in the third box.

You add 7 and 12 to get 19 to go in the fourth box.

You add 12 and 19 to get 31 to go in the fifth box.

5	7	12	19	31
---	---	----	----	----

Complete these rows of boxes using the rule shown above.

(a)

4	6			
---	---	--	--	--

[1]

(b)

			34	55
--	--	--	----	----

[2]

(c) Complete this row of boxes, writing your expressions in their simplest form.

a	b			
-----	-----	--	--	--

[2]

(d) Use your answer to (c) to help you fill in the missing numbers in this row of boxes.

6				57
---	--	--	--	----

[3]

- 18 Amin is attempting to solve the following equation.

$$(x + 1)(x + 4) = (x - 2)(x - 3)$$

His **incorrect** solution is shown below.

$$(x + 1)(x + 4) = (x - 2)(x - 3)$$

Step 1 $x^2 + 4x + x + 4 = x^2 - 3x - 2x + 6$

Step 2 $x^2 + 5x + 4 = x^2 - x + 6$

Step 3 $5x + 4 = -x + 6$

Step 4 $6x + 4 = 6$

Step 5 $6x = 2$

Step 6 $x = \frac{1}{3}$

- (a) Identify the step in which Amin made his first error and explain why this step is incorrect.

.....

.....

.....

..... [2]

- (b) Write out a correct solution to the equation. [2]

- 19 The perimeter of the triangle is the same length as the perimeter of the square.

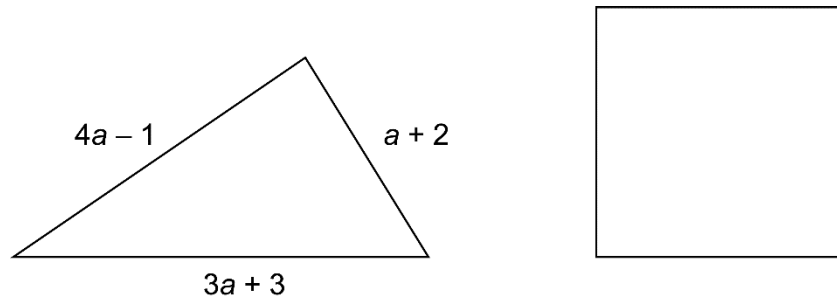

Find an expression for the length of one side of the square in terms of a .
Give your answer in its simplest form.

..... [4]

Summary of updates

Date	Version	Details
February 2024	1.1	Insertion of “You must show your working” to question 11 c
March 2025	1.2	Amendment to wording of section 13 of the mark scheme

Copyright Information

OCR is committed to seeking permission to reproduce all third-party content that it uses in the assessment materials. OCR has attempted to identify and contact all copyright holders whose work is used in this paper. To avoid the issue of disclosure of answer-related information to candidates, all copyright acknowledgements are reproduced in the OCR Copyright Acknowledgements Booklet. This is produced for each series of examinations and is freely available to download from our public website (www.ocr.org.uk) after the live examination series.

If OCR has unwittingly failed to correctly acknowledge or clear any third-party content in this assessment material, OCR will be happy to correct its mistake at the earliest possible opportunity.

For queries or further information please contact OCR, The Triangle Building, Shaftesbury Road, Cambridge CB2 8EA.

OCR is part of the Cambridge Assessment Group; Cambridge Assessment is the brand name of University of Cambridge Local Examinations Syndicate (UCLES), which is itself a department of the University of Cambridge.

OCR

Oxford Cambridge and RSA

F

Date – Morning/Afternoon

GCSE (9–1) Mathematics

J560/02 Paper 2 (Foundation Tier)

SAMPLE MARK SCHEME

Duration: 1 hour 30 minutes

MAXIMUM MARK 100

This document consists of 13 pages

Subject-Specific Marking Instructions

1. **M** marks are for using a correct method and are not lost for purely numerical errors.
A marks are for an accurate answer and depend on preceding **M** (method) marks. Therefore **M0 A1** cannot be awarded.
B marks are independent of **M** (method) marks and are for a correct final answer, a partially correct answer, or a correct intermediate stage.
SC marks are for special cases that are worthy of some credit.
2. Unless the answer and marks columns of the mark scheme specify **M** and **A** marks etc, or the mark scheme is 'banded', then if the correct answer is clearly given and is not from wrong working **full marks** should be awarded.

Do not award the marks if the answer was obtained from an incorrect method, ie incorrect working is seen and the correct answer clearly follows from it.

3. Where follow through (**FT**) is indicated in the mark scheme, marks can be awarded where the candidate's work follows correctly from a previous answer whether or not it was correct.

Figures or expressions that are being followed through are sometimes encompassed by single quotation marks after the word *their* for clarity, e.g. FT $180 \times (\textit{their} '37' + 16)$, or FT $300 - \sqrt{(\textit{their} '5^2 + 7^2')}$. Answers to part questions which are being followed through are indicated by e.g. FT $3 \times \textit{their} (a)$.

For questions with FT available you must ensure that you refer back to the relevant previous answer. You may find it easier to mark these questions candidate by candidate rather than question by question.

4. Where dependent (**dep**) marks are indicated in the mark scheme, you must check that the candidate has met all the criteria specified for the mark to be awarded.
5. The following abbreviations are commonly found in GCSE Mathematics mark schemes.
 - **figs 237**, for example, means any answer with only these digits. You should ignore leading or trailing zeros and any decimal point e.g. 237000, 2.37, 2.370, 0.00237 would be acceptable but 23070 or 2374 would not.
 - **isw** means **ignore subsequent working** after correct answer obtained and applies as a default.
 - **nfw** means **not from wrong working**.
 - **oe** means **or equivalent**.
 - **rot** means **rounded or truncated**.
 - **seen** means that you should award the mark if that number/expression is seen anywhere in the answer space, including the answer line, even if it is not in the method leading to the final answer
 - **soi** means **seen or implied**.

6. In questions with no final answer line, make no deductions for wrong work after an acceptable answer (ie **isw**) unless the mark scheme says otherwise, indicated by the instruction 'mark final answer'.
7. In questions with a final answer line following working space:
- (i) If the correct answer is seen in the body of working and the answer given on the answer line is a clear transcription error allow full marks unless the mark scheme says 'mark final answer'. Place the annotation ✓ next to the correct answer.
 - (ii) If the correct answer is seen in the body of working but the answer line is blank, allow full marks. Place the annotation ✓ next to the correct answer.
 - (iii) If the correct answer is seen in the body of working but a completely different answer is seen on the answer line, then accuracy marks for the answer are lost. Method marks could still be awarded. Use the M0, M1, M2 annotations as appropriate and place the annotation ✕ next to the wrong answer.
8. In questions with a final answer line:
- (i) If one answer is provided on the answer line, mark the method that leads to that answer.
 - (ii) If more than one answer is provided on the answer line and there is a single method provided, award method marks only.
 - (iii) If more than one answer is provided on the answer line and there is more than one method provided, award zero marks for the question unless the candidate has clearly indicated which method is to be marked.
9. In questions with no final answer line:
- (i) If a single response is provided, mark as usual.
 - (ii) If more than one response is provided, award zero marks for the question unless the candidate has clearly indicated which response is to be marked.
10. When the data of a question is consistently misread in such a way as not to alter the nature or difficulty of the question, please follow the candidate's work and allow follow through for **A** and **B** marks. Deduct 1 mark from any **A** or **B** marks earned and record this by using the MR annotation. **M** marks are not deducted for misreads.

11. Unless the question asks for an answer to a specific degree of accuracy, always mark at the greatest number of significant figures even if this is rounded or truncated on the answer line. For example, an answer in the mark scheme is 15.75, which is seen in the working. The candidate then rounds or truncates this to 15.8, 15 or 16 on the answer line. Allow full marks for the 15.75.
12. Ranges of answers given in the mark scheme are always inclusive.
13. For methods not provided for in the mark scheme (including visual representations such as bar models, ratio tables, etc) give as far as possible equivalent marks for equivalent work. If in doubt, consult your Team Leader.
14. Anything in the mark scheme which is in square brackets [...] is not required for the mark to be earned, but if present it must be correct.

Question		Answer	Marks	Part marks and guidance	
1	(a)	7	1 1 A01.3a		
	(b)	4	1 1 A01.3a		
2	(a)	0.1	2 2 A01.3a	M1 for 0.4 + 0.2 + 0.3 soi or 1 – <i>their</i> '0.9'	
	(b)	0.7	2 2 A01.3a	M1 for 0.4 and 0.3 identified	
3	(a)	Any two odd primes added correctly	1 1 A02.1a	e.g. 3 + 5 = 8	
	(b)	An odd integer squared with correct result	1 1 A02.1a	e.g. 5 ² = 25	
4		[£]1800	4 2 A01.3b 2 A03.1d	M1 for $\frac{1}{4} + \frac{1}{2} = \frac{3}{4}$ soi M1 for $\frac{1}{4}$ (of the rent) = 450 M1 for 450 × 4	oe using percentages or decimals
5	(a)	China	1 1 A02.3a		
	(b)	27 100 000	1 1 A01.3a		
	(c)	7.82×10^9	2 1 A01.2 1 A01.3a	M1 for attempting to multiply by 1000	
	(d)	7.85×10^7	2 2 A01.3a	M1 for 9.9 – 2.05 soi	

Question		Answer	Marks	Part marks and guidance																					
6	(a)	40 (cm)	2 1 AO1.3a 1 AO3.1a	M1 for $4 \times \text{their } \sqrt{100}$																					
	(b)	Correct working leading to 4 cm	4 1 AO1.3b 2 AO2.2 1 AO2.4a	B1 for area of triangle is 24 B1 for $\text{their } '24' \times 3$ B1 for $\text{their } '72' \div 18$ or area of parallelogram = $18h$																					
7	(a)	54	1 1 AO3.1a																						
	(b)	5	2 1 AO1.1 1 AO3.1a	M1 for a complete factor tree oe																					
8	(a)	8	3 2 AO1.3a 1 AO3.1b	M1 for dividing by 3 or 13 M1 for dividing by remaining factor																					
	(b)	Any three valid answers e.g. 2, 7, 23	3 1 AO1.1 2 AO3.1a	M1 for multiplying 3 by 13 M1 for dividing by 39 or listing multiples of 39																					
	(b)	Any three valid answers e.g. 2, 7, 23	3 1 AO1.1 2 AO3.1a	B1 for each If 0 scored, instead award SC1 for at least 3 primes and 3 squares seen																					
9	(a)	<table border="1"> <thead> <tr> <th>Prism</th> <th>Number of faces</th> <th>Number of edges</th> <th>Number of vertices</th> </tr> </thead> <tbody> <tr> <td>Triangular (3 sides)</td> <td>5</td> <td>9</td> <td>6</td> </tr> <tr> <td>Rectangular (4 sides)</td> <td>6</td> <td>12</td> <td>8</td> </tr> <tr> <td>Pentagonal (5 sides)</td> <td>7</td> <td>15</td> <td>10</td> </tr> <tr> <td>Hexagonal (6 sides)</td> <td>8</td> <td>18</td> <td>12</td> </tr> </tbody> </table>	Prism	Number of faces	Number of edges	Number of vertices	Triangular (3 sides)	5	9	6	Rectangular (4 sides)	6	12	8	Pentagonal (5 sides)	7	15	10	Hexagonal (6 sides)	8	18	12	2 1 AO1.1 1 AO2.1a	B1 for 2 correct	
Prism	Number of faces	Number of edges	Number of vertices																						
Triangular (3 sides)	5	9	6																						
Rectangular (4 sides)	6	12	8																						
Pentagonal (5 sides)	7	15	10																						
Hexagonal (6 sides)	8	18	12																						
	(b)	300 (edges) 200 (vertices)	1 1 2 AO2.1a																						

Question		Answer	Marks	Part marks and guidance	
	(c)	$F = N + 2$ oe	2 1 A02.3a 1 A02.3b	B1 for $N + 2$ (without a subject)	Condone for B1 a correct word formula
10	(a)	(i)	Positive correlation	1 1 A01.1	Condone 'positive' or correct description, e.g. 'As the temperature increases, more ice creams are sold'
		(ii)	Correct reason, e.g. 'He sold far more ice creams than you would expect him to for a 20°C day'	1 1 A02.3a	
	(b)	(i)	75-95	1 1 A01.3a	
		(ii)	140-170	1 1 A01.3a	
		(iii)	The (b)(i) prediction is more reliable, as it is within the range of the given data	2 1 A02.1b 1 A02.4a	B1 for (b)(i) prediction identified with partial reason
	(c)		No, because there may be other factors involved	2 1 A02.5a 1 A03.4b	B1 for 'No', with partial reason
11	(a)		45 000	2 2 A01.3a	M1 for $50\,000 \times 0.9$ soi or $50\,000 - 5000$
	(b)		Total value of goods sold in May was £32 805, which is less than £35 000	3 3 A02.2	M2 for $50\,000$ (or $45\,000$) $\times 0.9$ used three times (or two times) soi or decreasing by 10% three times Or M1 for $45\,000 \times 0.9$ or $45\,000 - 4500$
					Implied by 36 450 and 32 805 Implied by 40 500

Question		Answer	Marks	Part marks and guidance	
	(c)	8[%] with correct working	5 3 AO1.3b 2 AO3.1d	B4 for answer 108[%] or 1.08 or [0].08 with correct working or M3 for $1.2 \times [0].9$ oe or for $\frac{100\,000 \times 1.2 \times [0].9[-100\,000]}{100\,000}$ or M2 for 1.2 and [0].9 or M1 for 1.2 or [0].9 If 0 or 1 scored, instead award SC2 for answer 8[%] with no working or insufficient working If 0 scored, instead award SC1 for 108[%] or 1.08 or [0].08 with no working or insufficient working	“Correct working” requires evidence of at least M3 or alternative convincing approach Throughout, percentage calculations may be performed in stages e.g. 120% by adding 20% e.g. $100\,000 \times 1.2 \times [0].9$ or $120\,000 \times [0].9$ e.g. $100\,000 \times 1.2$ implied by 120 000
12	(a)	6	2 2 AO1.3a	M1 for $3x = 18$	

Question		Answer	Marks	Part marks and guidance	
	(b)	-3 -5	3 3 A01.3a	M2 for $(x + 3)(x + 5)$ seen or implied in table Or M1 for $(x \pm 3)(x \pm 5)$ seen or pair of factors giving two correct terms seen or implied in table And B1 for correct solutions FT <i>their</i> quadratic factors	
13	(a)	24 cm by 16 cm 12 cm by 8 cm	2 1 A01.3a 1 A03.1c	B1 for each	Answers may be indicated on the list in the question

Question		Answer	Marks	Part marks and guidance
	(b)	50	3 1 AO1.3b 2 AO3.1d	M1 for $\frac{45}{9}$ or $\frac{60}{6}$ M1 for <i>their</i> '5' \times <i>their</i> '10' SC2 for 42 or for area calculation leading to incorrect answer
14	(a)	[p =] 5 [q =] -5	2 1 AO1.2 1 AO1.3a	B1 for each
	(b)	c = 3a d = a + b e = a - b	3 3 AO1.3a	B1 for each
15	(a)	800	2 1 AO1.3b 1 AO3.1c	M1 for unitary work, e.g. 1 person does 200 letters in 2 hours
	(b)	30 minutes oe	4 2AO2.1a 2 AO3.1d	M1 for 1 person does 100 letters in 1 hour M1 for 5 people do 1000 letters in 2 hours M1 for 4 people do 1000 letters in 2.5 hours FT from <i>their</i> rate in (a) throughout

Question		Answer	Marks	Part marks and guidance	
	(c)	Correct comment on the reasonableness of her assumption e.g. 'She has assumed that 'all day' means 'for 24 hours', but it is not reasonable for them to work without a break.' Correct comment on the effect it will have on the answer e.g. 'They can't work at that rate for that long, so her answer is an over-estimate.'	2 1 AO3.4a 1 AO3.5	B1 for each	
16	(a)	Outcomes not equally likely oe	1 1 AO3.4b		
	(b)	Larger number of trials	1 1 AO3.4a		
	(c)	0.09 – 0.16	2 1 AO1.3a 1 AO2.1b	M1 for $\left(\frac{48}{150}\right)^2$ or 0.35^2 or any reasonable estimate (FT their (b))	
17	(a)	10, 16, 26	1 1 AO1.3a		
	(b)	8, 13, 21	2 1 AO1.3a 1 AO3.1a	M1 for one correct subtraction of two boxes	
	(c)	$a + b$, $a + 2b$, $2a + 3b$	2 2 AO1.3a	M1 for two expressions correct	
	(d)	15, 21, 36	3 1 AO1.3a 2 AO2.1a	M1 for <i>their</i> ' $2a + 3b = 57$ M1 for substituting $a = 6$ into <i>their</i> final expression and solving for b	
18	(a)	The first error is in step 2 $-3x - 2x = -5x$, not $-x$ as given	2 2 AO2.5a	B1 for identifying step 2 B1 for explaining the error	

Question		Answer	Marks	Part marks and guidance	
	(b)	$[x^2 + 4x + x + 4 = x^2 - 3x - 2x + 6]$ $x^2 + 5x + 4 = x^2 - 5x + 6$ $5x + 4 = -5x + 6$ $10x + 4 = 6$ $10x = 2$ $x = \frac{1}{5}$	2 2 AO1.3a	M1 for an attempt to correct the solution in line with <i>their</i> answer to (a)	
19		$2a + 1$	4 1 AO1.3b 2 AO3.1b 1 AO3.2	M1 for $a + 2 + 3a + 3 + 4a - 1$ M1 for collecting terms M1 for dividing <i>their</i> '8a + 4' by 4	

Assessment Objectives (AO) Grid

Question	AO1	AO2	AO3	Total
1(a)	1			1
1(b)	1			1
2(a)	2			2
2(b)	2			2
3(a)		1		1
3(b)		1		1
4	2		2	4
5(a)		1		1
5(b)	1			1
5(c)	2			2
5(d)	2			2
6(a)	1		1	2
6(b)	1	3		4
7(a)			1	1
7(b)	1		1	2
8(a)	2		1	3
8(b)	1		2	3
9(a)	1	1		2
9(b)		2		2
9(c)		2		2
10(a)(i)	1			1
10(a)(ii)		1		1
10(b)(i)	1			1
10(b)(ii)	1			1
10(b)(iii)		2		2
10(c)		1	1	2
11(a)	2			2
11(b)		3		3
11(c)	3		2	5
12(a)	2			2
12(b)	3			3
13(a)	1		1	2
13(b)	1		2	3
14(a)	2			2
14(b)	3			3
15(a)	1		1	2
15(b)		2	2	4
15(c)			2	2
16(a)			1	1
16(b)			1	1
16(c)	1	1		2
17(a)	1			1
17(b)	1		1	2
17(c)	2			2
17(d)	1	2		3
18(a)		2		2
18(b)	2			2
19	1		3	4
Totals	50	25	25	100

GCSE (9–1) Mathematics J560/03 Paper 3 (Foundation Tier) Sample Question Paper

F

Date – Morning/Afternoon

Version 1.2

Time allowed: 1 hour 30 minutes



You may use:

- A scientific or graphical calculator
- Geometrical instruments
- Tracing paper



First name										
Last name										
Centre number						Candidate number				

INSTRUCTIONS

- Use black ink. You may use an HB pencil for graphs and diagrams.
- Complete the boxes above with your name, centre number and candidate number.
- Answer **all** the questions.
- Read each question carefully before you start to write your answer.
- Where appropriate, your answers should be supported with working. Marks may be given for a correct method even if the answer is incorrect.
- Write your answer to each question in the space provided.
- Additional paper may be used if required but you must clearly show your candidate number, centre number and question number(s).
- Do **not** write in the bar codes.

INFORMATION

- The total mark for this paper is **100**.
- The marks for each question are shown in brackets [].
- Use the π button on your calculator or take π to be 3.142 unless the question says otherwise.
- This document consists of **20** pages.

Answer **all** the questions

1 (a) Solve.

(i) $2x = 18$

(a)(i) $x = \dots\dots\dots$ [1]

(ii) $x + 2 = 5$

(ii) $x = \dots\dots\dots$ [1]

(iii) $\frac{x}{3} = 15$

(iii) $x = \dots\dots\dots$ [1]

(b) (i) Find the value of t when $g = 4$ and $h = 7$.

$$t = 12g - 5h$$

(b)(i) $t = \dots\dots\dots$ [2]

(ii) Rearrange to make r the subject.

$$4r - p = q$$

(ii) $\dots\dots\dots$ [2]

- 2 Cambury Council asked 60 customers what they thought of the local leisure centre. The results are shown in this bar chart.

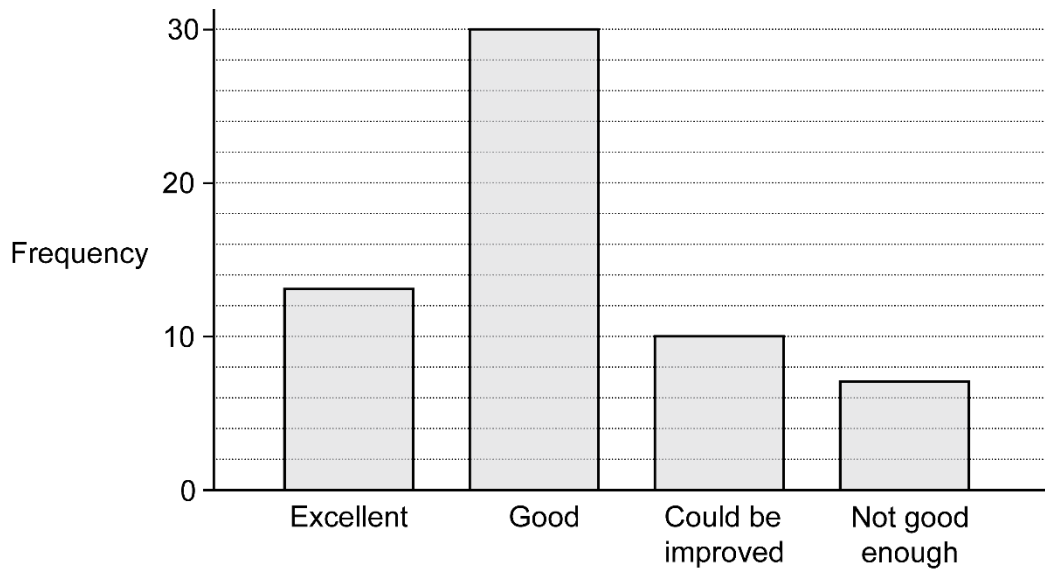

Draw and label a pie chart to represent this data.

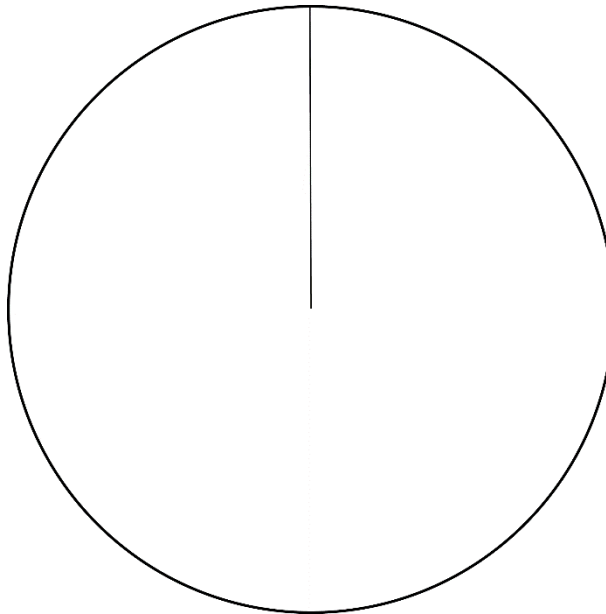

[5]

3 (a) How many 20p coins would you need to make up £7000?

(a) [2]

(b) Each 20p coin weighs 5g.

Lizzie says

I can lift £7000 worth of 20p coins.

Is Lizzie's claim reasonable?

Show your working and state any assumptions you have made.

..... because
..... [4]

(c) How have any assumptions you have made affected your answer to part (b)?

..... [1]

4 Antonio works Monday, Tuesday and Wednesday.

He starts work at 4.00 pm and finishes at 10.30 pm.
Antonio is paid £10 per hour on weekdays.

One week, he also works for 4 hours on Sunday.
He is paid 50% more on Sundays.

How much does Antonio earn altogether this week?
You must show your working.

£ [6]

5 Darren says

I can run 100 m in 15 seconds, so I should be able to run 800 m in 120 seconds.

Do you think that he would take more or less than 120 seconds to run 800 m? Explain your answer, with reference to any assumptions Darren has made.

..... because

.....

.....

..... [3]

- 6 Jo makes a pendant from a rectangular piece of silver.

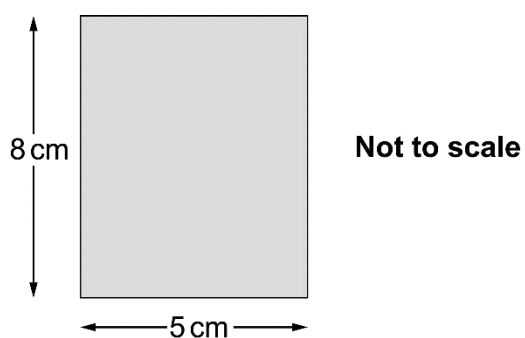

- (a) Work out the area of this rectangle.

(a) cm^2 [1]

- (b) To complete the pendant, Jo cuts two semicircles of radius 1 cm from the rectangle, as shown below.

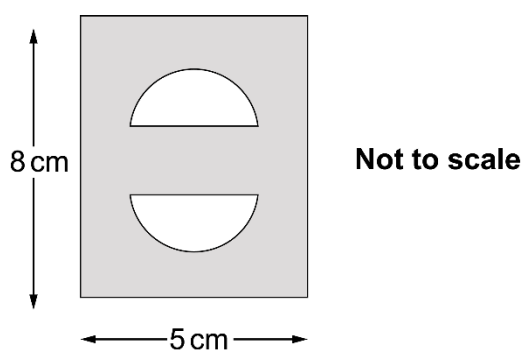

Show that the shaded area is 36.9 cm^2 correct to three significant figures.

[4]

(c) The silver Jo uses is 2 mm thick.

Find the volume of silver in the pendant.
Give your answer in cm^3 .

(c) cm^3 [3]

- 7 PQRS is a rectangle.
A, B, C and D are points on SP, PQ, QR and RS respectively.
AC is the line of symmetry for the diagram.

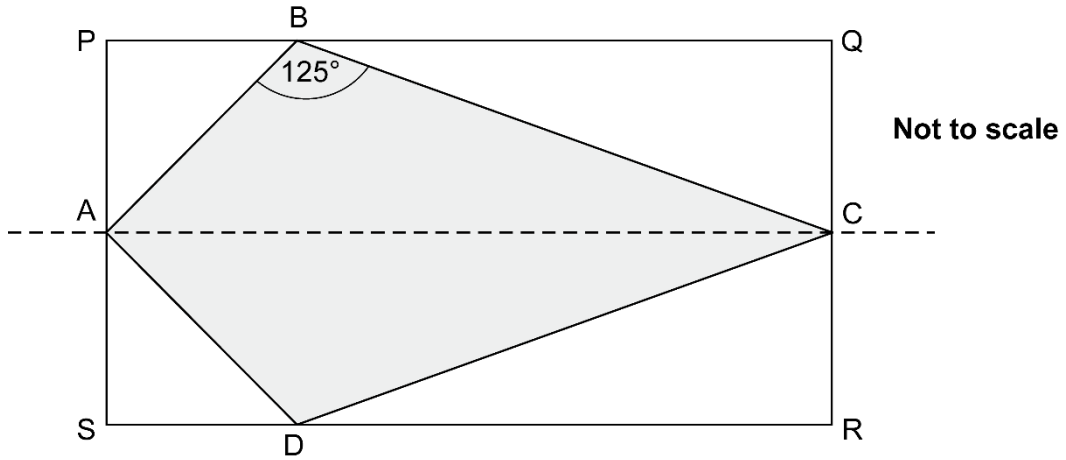

- (a) Angle $ABC = 125^\circ$.

Write down the size of angle ADC .

(a) Angle $ADC = \dots\dots\dots^\circ$ [1]

- (b) AP is the same length as PB.

Work out the size of angle BCD .
You must show your working.

(b) Angle $BCD = \dots\dots\dots^\circ$ [4]

8 (a) The n th term of a sequence is given by $3n + 5$.

Explain why 21 is not a term in this sequence.

.....
..... [2]

(b) Here are the first three terms in a sequence.

1 2 4

This sequence can be continued in different ways.

(i) Find one rule for continuing the sequence and give the next two terms.

Rule 1

Next two terms [2]

(ii) Find a second rule for continuing the sequence and give the next two terms.

Rule 2

Next two terms [2]

9 Three friends, Ann (A), Bob (B) and Carol (C), go on holiday together.

(a) They book a row of three seats on the plane.
When they arrive at the plane they sit in a random order.

(i) List all the different orders they could sit on the three seats.
The first one has been done for you.

Seat 1	Seat 2	Seat 3
A	B	C

[2]

(ii) What is the probability that Ann and Carol sit next to each other?

(a)(ii) [1]

(iii) What is the probability that Bob sits in seat 1 with Ann next to him?

(iii) [1]

- (b) Ann, Bob and Carol have a total budget of £500 to rent a holiday apartment. The apartment normally costs £50 per night, but they can get a 20% discount if they book early.

Calculate how many extra nights they can stay in the apartment if they book early. You must show your working.

(b) nights [4]

10 Calculate.

(a) $\sqrt{3136}$

(a) [1]

(b) $\sqrt[4]{625}$

(b) [1]

(c) 5^{-2}

(c) [1]

11 Ema has done some calculations.

For each calculation, explain how you know the answer is wrong without working out the correct answer.

(a) $0.38 \times 0.26 = 0.827$

.....
 [1]

(b) $\frac{3}{4} + \frac{2}{3} = \frac{5}{7}$

.....
 [1]

12 Shinya's internet service provider gives him a graph of his internet usage in the first part of February.

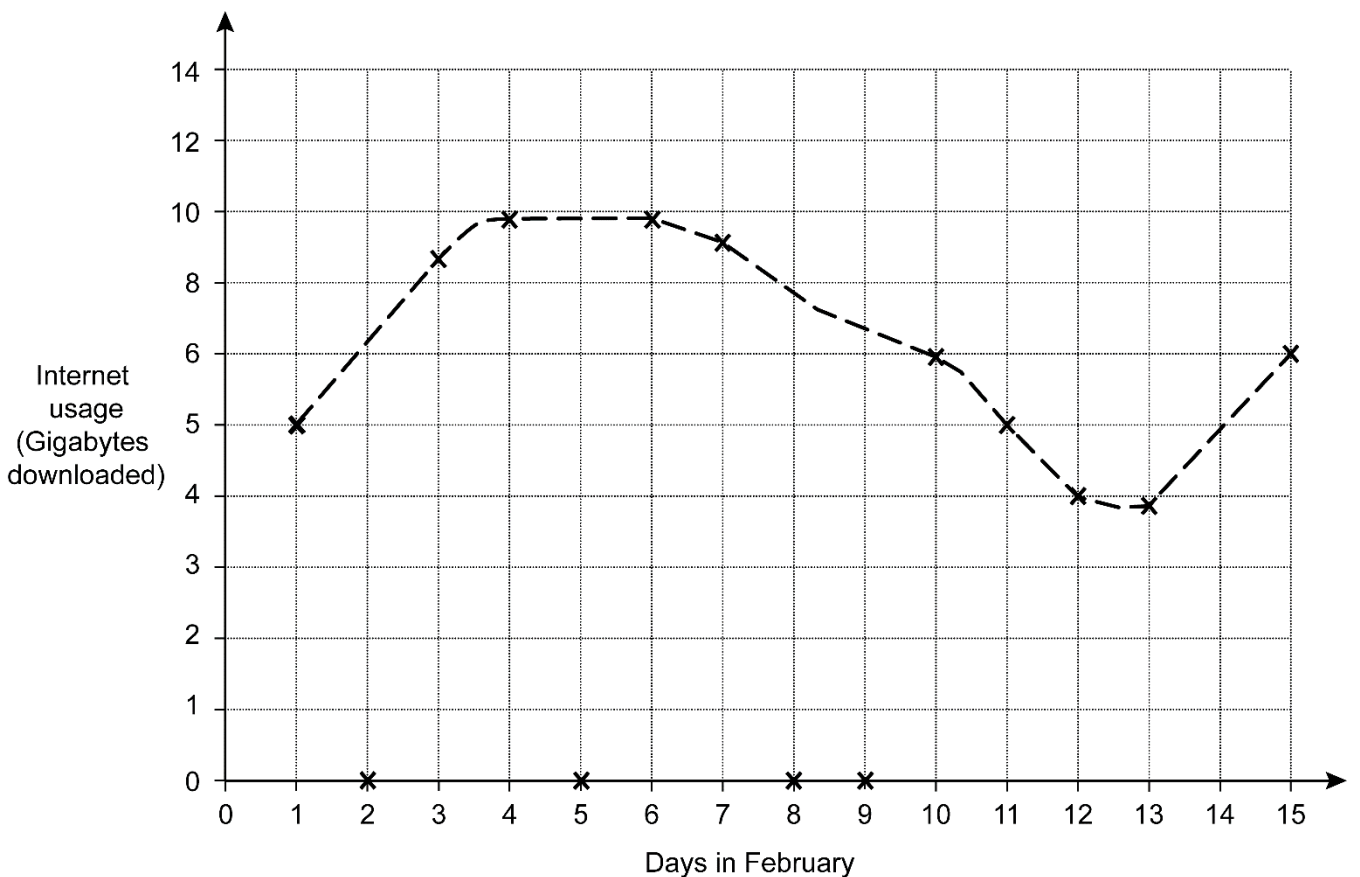

State two reasons why this graph is misleading.

- 1
- 2

[2]

- 13 (a) Mia cycled 23 km, correct to the nearest km.

What is the least distance Mia could have cycled?

(a) km [1]

- (b) A number x , rounded to one decimal place, is 4.7.
So the error interval for x is given by $4.65 \leq x < 4.75$.

- (i) A number y , rounded to **two** decimal places, is 4.13.

Write down the error interval for y .

(b)(i) [2]

- (ii) A number z , rounded to two significant figures, is 4700.

Write down the error interval for z .

(ii) [2]

- 14 This frequency diagram summarises the number of minutes Astrid's train was late over the last 50 days.

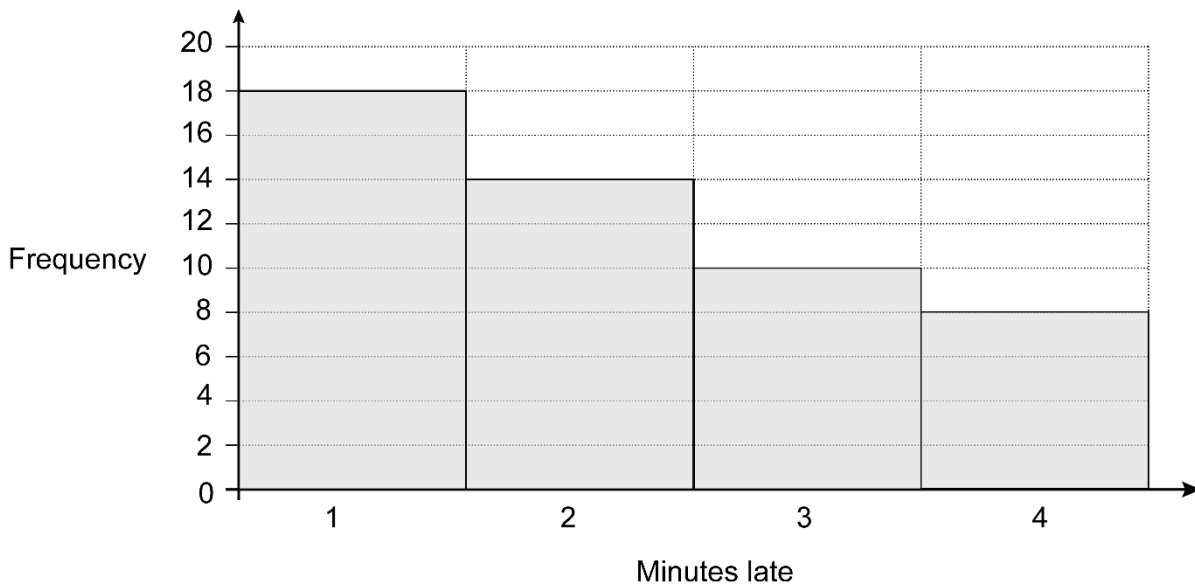

- (a) Use information from this diagram to estimate the probability that her train will be 4 minutes late tomorrow.

(a) [2]

- (b) Explain whether your answer to part (a) gives a reliable probability.

.....
 [1]

15 In the diagram below, AE and BD are straight lines.

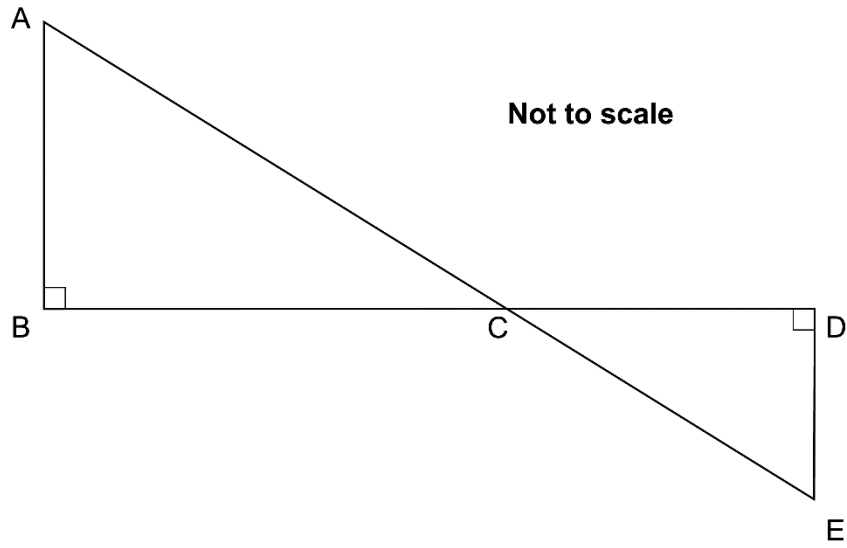

(a) Show that triangles ABC and EDC are similar.

.....

.....

.....

.....

.....

.....

..... [3]

(b) The length DE is 3.5 m.
The ratio $BC : CD = 3 : 1$.

Find the length AB.

(b) m [2]

16 Leo is using these numbers to make a new number.

11

1

3

6

- He can use brackets, +, −, × and ÷ as often as he wishes.
- He cannot use any number more than once.
- He cannot use powers.
- He cannot put numbers together, e.g. he can't use 136.

What is the biggest number he can make?
Show how he can make this number.

.....

.....

.....

..... [4]

17 180 g of copper is mixed with 105 g of zinc to make an alloy.

The density of copper is 9 g/cm^3 .

The density of zinc is 7 g/cm^3 .

(a) Work out the volume of copper used in the alloy.

(a) cm^3 [2]

(b) What is the density of the alloy?

(b) g/cm^3 [4]

18 (a) (i) Solve.

$$5x + 1 > x + 13$$

(a)(i) [3]

(ii) Write down the largest integer that satisfies $5x - 1 < 10$.

(ii) [1]

(b) Solve.

$$3x^2 = 75$$

(b) $x =$ [2]

(c) Solve.

$$4x + 3y = 5$$

$$2x + 3y = 1$$

(c) $x =$

$y =$

[3]

19 Here are the interest rates for two accounts.

Account A
Interest: 3% per year compound interest.
No withdrawals until the end of three years.

Account B
Interest: 4% for the first year, 3% for the second year and 2% for the third year.
Withdrawals allowed at any time.

Derrick has £10 000 he wants to invest.

- (a) Calculate which account would give him most money if he invests his money for 3 years. Give the difference in the interest to the nearest penny. You must show your working.

(a) Account byp [5]

- (b) Explain why he might **not** want to use Account A.

.....
 [1]

Summary of updates

Date	Version	Details
February 2024	1.1	Insertion of “You must show your working” to questions 4, 7(b) and 19. Insertion of ‘because’ to the answer lines in questions 3(b) and 5
March 2025	1.2	Amendment to wording of section 13 of the mark scheme

Copyright Information

OCR is committed to seeking permission to reproduce all third-party content that it uses in the assessment materials. OCR has attempted to identify and contact all copyright holders whose work is used in this paper. To avoid the issue of disclosure of answer-related information to candidates, all copyright acknowledgements are reproduced in the OCR Copyright Acknowledgements Booklet. This is produced for each series of examinations and is freely available to download from our public website (www.ocr.org.uk) after the live examination series.

If OCR has unwittingly failed to correctly acknowledge or clear any third-party content in this assessment material, OCR will be happy to correct its mistake at the earliest possible opportunity.

For queries or further information please contact OCR, The Triangle Building, Shaftesbury Road, Cambridge CB2 8EA.

OCR is part of the Cambridge Assessment Group; Cambridge Assessment is the brand name of University of Cambridge Local Examinations Syndicate (UCLES), which is itself a department of the University of Cambridge.

OCR

Oxford Cambridge and RSA

F

Date – Morning/Afternoon

GCSE (9–1) Mathematics

J560/03 Paper 3 (Foundation Tier)

SAMPLE MARK SCHEME

Duration: 1 hour 30 minutes

MAXIMUM MARK 100

This document consists of 15 pages

Subject-Specific Marking Instructions

1. **M** marks are for using a correct method and are not lost for purely numerical errors.
A marks are for an accurate answer and depend on preceding **M** (method) marks. Therefore **M0 A1** cannot be awarded.
B marks are independent of **M** (method) marks and are for a correct final answer, a partially correct answer, or a correct intermediate stage.
SC marks are for special cases that are worthy of some credit.
2. Unless the answer and marks columns of the mark scheme specify **M** and **A** marks etc, or the mark scheme is 'banded', then if the correct answer is clearly given and is not from wrong working **full marks** should be awarded.

Do not award the marks if the answer was obtained from an incorrect method, i.e. incorrect working is seen and the correct answer clearly follows from it.

3. Where follow through (**FT**) is indicated in the mark scheme, marks can be awarded where the candidate's work follows correctly from a previous answer whether or not it was correct.

Figures or expressions that are being followed through are sometimes encompassed by single quotation marks after the word *their* for clarity, e.g. FT $180 \times (\textit{their} '37' + 16)$, or FT $300 - \sqrt{(\textit{their} '5^2 + 7^2')}$. Answers to part questions which are being followed through are indicated by e.g. FT 3 \times *their* (a).

For questions with FT available you must ensure that you refer back to the relevant previous answer. You may find it easier to mark these questions candidate by candidate rather than question by question.

4. Where dependent (**dep**) marks are indicated in the mark scheme, you must check that the candidate has met all the criteria specified for the mark to be awarded.
5. The following abbreviations are commonly found in GCSE Mathematics mark schemes.
 - **figs 237**, for example, means any answer with only these digits. You should ignore leading or trailing zeros and any decimal point e.g. 237000, 2.37, 2.370, 0.00237 would be acceptable but 23070 or 2374 would not.
 - **isw** means **ignore subsequent working** after correct answer obtained and applies as a default.
 - **nfw** means **not from wrong working**.
 - **oe** means **or equivalent**.
 - **rot** means **rounded or truncated**.
 - **seen** means that you should award the mark if that number/expression is seen anywhere in the answer space, including the answer line, even if it is not in the method leading to the final answer
 - **soi** means **seen or implied**.

6. In questions with no final answer line, make no deductions for wrong work after an acceptable answer (i.e. **isw**) unless the mark scheme says otherwise, indicated by the instruction 'mark final answer'.
7. In questions with a final answer line following working space:
- (i) If the correct answer is seen in the body of working and the answer given on the answer line is a clear transcription error allow full marks unless the mark scheme says 'mark final answer'. Place the annotation ✓ next to the correct answer.
 - (ii) If the correct answer is seen in the body of working but the answer line is blank, allow full marks. Place the annotation ✓ next to the correct answer.
 - (iii) If the correct answer is seen in the body of working but a completely different answer is seen on the answer line, then accuracy marks for the answer are lost. Method marks could still be awarded. Use the M0, M1, M2 annotations as appropriate and place the annotation ✕ next to the wrong answer.
8. In questions with a final answer line:
- (i) If one answer is provided on the answer line, mark the method that leads to that answer.
 - (ii) If more than one answer is provided on the answer line and there is a single method provided, award method marks only.
 - (iii) If more than one answer is provided on the answer line and there is more than one method provided, award zero marks for the question unless the candidate has clearly indicated which method is to be marked.
9. In questions with no final answer line:
- (i) If a single response is provided, mark as usual.
 - (ii) If more than one response is provided, award zero marks for the question unless the candidate has clearly indicated which response is to be marked.
10. When the data of a question is consistently misread in such a way as not to alter the nature or difficulty of the question, please follow the candidate's work and allow follow through for **A** and **B** marks. Deduct 1 mark from any **A** or **B** marks earned and record this by using the MR annotation. **M** marks are not deducted for misreads.

11. Unless the question asks for an answer to a specific degree of accuracy, always mark at the greatest number of significant figures even if this is rounded or truncated on the answer line. For example, an answer in the mark scheme is 15.75, which is seen in the working. The candidate then rounds or truncates this to 15.8, 15 or 16 on the answer line. Allow full marks for the 15.75.
12. Ranges of answers given in the mark scheme are always inclusive.
13. For methods not provided for in the mark scheme (including visual representations such as bar models, ratio tables, etc) give as far as possible equivalent marks for equivalent work. If in doubt, consult your Team Leader.
14. Anything in the mark scheme which is in square brackets [...] is not required for the mark to be earned, but if present it must be correct.

Question		Answer	Marks	Part marks and guidance	
3	(a)	35 000	2 1 AO1.3a 1 AO3.1c	M1 for 7000×5 oe	
	(b)	No, following correct working and estimates	4 1 AO1.3a 1 AO2.4a 1 AO3.1d 1 AO3.3	$\frac{\textit{their '35 000'} \times 5}{1000}$ M2 for or M1 for $\textit{their '35 000'} \times 5$ AND B1 for valid estimate of weight a person can carry (5 kg–75 kg) Allow estimates for $\textit{their '35 000'}$	£7000 of 5 g coins weigh 175 kg 'No' may be implied by seeing mass of coins and estimate of carry weight identified Accept any valid alternate argument
	(c)	Valid comment about how a change in the assumption would influence their decision	1 1 AO3.5	FT from part (b)	

Question		Answer	Marks	Part marks and guidance	
4		255 with correct working	<p>6</p> <p>2 AO1.3a 4 AO3.1d</p>	<p>M1 for 6.5 [hours] M2 for <i>their</i> '6.5' × 10 × 3 oe or M1 for <i>their</i> '6.5' × 10 or <i>their</i> '6.5' × 3</p> <p>AND</p> <p>M1 for [£]15 M1 for <i>their</i> '15' × 4</p> <p>If 0, 1 or 2 scored, instead award SC3 for answer 255 with no working or insufficient working</p> <p>If 0 or 1 scored, instead award SC2 for 195 or 60 with no working or insufficient working</p> <p>If 0 scored, instead award SC1 for 19.5 or 65 with no working or insufficient working</p>	<p>"Correct working" requires evidence of at least M2 and M1</p>
5		He has assumed he can run 800 m at the same speed as he can run 100 m, but he will run 800 m at a slower speed, therefore it will take him more than 120 s	<p>3</p> <p>1 AO2.1a 1 AO3.4a 1 AO3.5</p>	<p>B1 for correct reference to Darren's assumption</p> <p>or $\frac{100}{15} = \frac{800}{120}$ soi</p> <p>B1 for 'his speed will be slower over 800m' oe</p>	

Question		Answer	Marks	Part marks and guidance	
6	(a)	40	1 1 AO1.3a		
	(b)	Correct reasoning leading to 36.9	4 1 AO1.3b 2 AO2.2 1 AO3.1b	M2 for $\pi \times 1^2$ or M1 for $\frac{1}{2} \times \pi \times 1^2$ AND M1 for <i>their</i> '40' – $\pi \times 1^2$	
	(c)	7.38 or better	3 1 AO1.3a 2 AO3.1b	M1 for 2 mm = 0.2 cm soi M1 for $36.9 \times$ <i>their</i> '0.2' oe	
7	(a)	125	1 1 AO1.2		
	(b)	20 with correct working	4 2 AO2.1a 2 AO2.4a	B1 for PAB = 45 B1 for BAD = 90 M1 for $360 - (\textit{their} '125' + their '90' + 125) If 0 scored, instead award SC1 for answer 20 with no working or insufficient working $	"Correct working" requires evidence of at least M1 <u>Alternative method</u> B1 for PAB = 45 B1 for BAC = 45 M1 for $180 - \textit{their}$ 45 – 125
8	(a)	$\frac{21-5}{3}$ is not an integer	2 1 AO1.3a 1 AO2.4a	M1 for $\frac{21-5}{3}$ or for 20 and 23 seen	

Question		Answer	Marks	Part marks and guidance	
	(b)	(i)	Any valid rule Correct next two terms FT <i>their</i> rule	1 1 1 AO1.3a 1 AO2.1a	For example, 'Add one more to the difference each time' 7 11 'Doubling' 8 16
		(ii)	Any valid rule Correct next two terms FT <i>their</i> rule	1 1 1 AO1.3a 1 AO2.1a	For example, 'Add one more to the difference each time' 7 11 'Doubling' 8 16 Answer must be different to part (b)(i)
9	(a)	(i)	ACB, BAC, BCA, CAB, CBA	2 2 AO1.3a	B1 for at least three more ways of seating listed
		(ii)	$\frac{2}{3}$ oe	1 1 AO2.1b	FT on answer to part (a)(i)
		(iii)	$\frac{1}{6}$ oe	1 1 AO2.1b	FT on answer to part (a)(i)

Question		Answer	Marks	Part marks and guidance	
	(b)	2 with correct working	4 1 A01.3b 2 A03.1d 1 A03.3	M1 for 50×0.8 oe implied by 40 or for $\frac{500}{50}$ implied by 10 M1 for $\frac{500}{\text{their } 40}$ implied by 12.5 M1 for <i>their</i> 12.5 – <i>their</i> 10 If 0 scored, instead award SC1 for answer 2	“Correct working” requires evidence of at least M1M1
10	(a)	56	1 1 A01.3a		
	(b)	5	1 1 A01.3a		
	(c)	$\frac{1}{25}$ or 0.04	1 1 A01.3a		
11	(a)	Explanation, e.g. there should be 4 dp in the answer or the answer should be smaller than 0.38 (or 0.26) or because $0.4 \times 0.3 = 0.12$	1 1 A02.5a	Clear sensible reason (not just giving the actual answer with no working or explanation)	Condone: multiplying two decimals means a smaller number oe
	(b)	Explanation, e.g. the answer should be bigger than 1 because both $\frac{3}{4}$ and $\frac{2}{3}$ are bigger than $\frac{1}{2}$ oe or the answer should be bigger than $\frac{3}{4}$ but $\frac{5}{7}$ is smaller than $\frac{3}{4}$ oe	1 1 A02.5a		Exemplars for 1 mark: <ul style="list-style-type: none"> • “you don’t add fractions by adding tops and bottoms” • “you don’t add the denominators” • “you have to find a common denominator first” • $\frac{3}{4} + \frac{2}{3}$ is obviously > 1

Question		Answer	Marks	Part marks and guidance	
12		Vertical axis is not consistent The line does not represent the days when he doesn't use the internet	2 2 A02.5b	B1 for each valid comment	
13	(a)	22.5	1 1 A01.3a		
	(b) (i)	$4.125 \leq y < 4.135$	2 1 A01.2 1 A01.3a	B1 for either limit with correct inequality sign	Condone using x instead of y
	(ii)	$4650 \leq z < 4750$	2 1 A01.2 1 A01.3a	B1 for either limit with correct inequality sign	Condone using x instead of z
14	(a)	$\frac{8}{50}$ oe	2 1 A02.3a 1 A03.1c	B1 for $\frac{n}{50}$	
	(b)	Any comment with valid reason	1 1 A03.4b		
15	(a)	Angles at B and D are right angles Angles ACB and ECD are vertically opposite oe Three equal angles (angle sum of a triangle), hence triangles are similar oe	1 1 1 2 A01.3b 1 A02.4a		
	(b)	10.5	2 2 A01.3a	M1 for 3.5×3 oe	

Question		Answer	Marks	Part marks and guidance	
16		Correct answer (264) with complete correct working, e.g. $(3 + 1) \times 6 \times 11$	4 1 AO1.3a 3 AO3.1a	M3 for correct working but no final answer stated $(3 + 1) \times 6 \times 11$ or the working is poorly communicated but is clear, e.g. $(3 + 1) \times 6 \times 11 = 264$ or number greater than 200 with complete correct working Or M2 for 264 with no (or incomplete) working or for acceptable number over 200 with poorly communicated working Or M1 for number greater than 200 with no, or incomplete, working or for $(3 \times 6) \times 11$ [$\times 1$] condoning error in calculation or for two trials leading to numbers below 200 (condone poor communication) or acceptable calculation with <i>their</i> answer minimum 200 but error in evaluation	Working correctly communicated in stages is acceptable for 4 marks, e.g. $3 + 1 = 4$, $4 \times 6 = 24$, $24 \times 11 = 264$ Full written explanation is also acceptable For 1 or 2 marks 'acceptable' implies number, minimum 200, that can be made
17	(a)	20	2 1 AO1.1 1 AO2.3a	M1 for $D = \frac{M}{V}$ soi	Can be implied by an answer of 2

Question		Answer	Marks	Part marks and guidance
	(b)	$8\frac{1}{7}$ or 8.14[...]	4 2 AO1.3b 2 AO3.1d	<p>M1 for 15 or $105 \div 7$</p> <p>AND</p> $\frac{180 + 105}{20 + 15}$ <p>M2 for <i>their</i>($20 + 15$)</p> $\frac{18 + 10.5}{2 + 1.5}$ <p>or <i>their'</i>($2 + 1.5$)'</p> <p>or M1 for some attempt to find $\frac{\text{total mass}}{\text{total volume}}$</p>
18	(a)	(i) $x > 3$	3 3 AO1.3a	<p>M1 for $4x$ soi</p> <p>M1 for 12 soi</p>
		(ii) 2	1 1 AO1.3a	
	(b)	[+]5 -5	2 2 AO1.3a	<p>M1 for $x^2 = 25$</p> <p>If 0 scored, instead award SC1 for 5 seen as answer</p>
	(c)	[x =] 2 [y =] -1	3 3 AO1.3b	<p>M1 for eliminating one variable</p> <p>M1 for correct substitution of <i>their</i> x or y</p>

Question		Answer	Marks	Part marks and guidance	
19	(a)	(Account) A (by) 103[p] with correct working	5 3 AO1.3b 1 AO3.1d 1 AO3.3	M2 for $[10\,000 \times] 1.03^3$ implied by 10 927.27 or M1 for 10 300 and 10 609 AND M2 for $[10\,000 \times] 1.04 \times 1.03 \times 1.02$ implied by 10 926.24 or M1 for 10 400 and 10 712 If 0 , 1 or 2 scored, instead award SC3 for A by 103[p] with no working or insufficient working	“Correct working” requires evidence of at M2M2 May be done in stages May be done in stages
	(b)	He may not want to leave it there for 3 years	1 1 AO2.3a	Accept any valid reason	

Assessment Objectives (AO) Grid

Question	AO1	AO2	AO3	Total
1(a)(i)	1			1
1(a)(ii)	1			1
1(a)(iii)	1			1
1(b)(i)	2			2
1(b)(ii)	2			2
2	1	4		5
3(a)	1		1	2
3(b)	1	1	2	4
3(c)			1	1
4	2		4	6
5		1	2	3
6(a)	1			1
6(b)	1	2	1	4
6(c)	1		2	3
7(a)	1			1
7(b)		4		4
8(a)	1	1		2
8(b)(i)	1	1		2
8(b)(ii)	1	1		2
9(a)(i)	2			2
9(a)(ii)		1		1
9(a)(iii)		1		1
9(b)	1		3	4
10(a)	1			1
10(b)	1			1
10(c)	1			1
11(a)		1		1
11(b)		1		1
12		2		2
13(a)	1			1
13(b)(i)	2			2
13(b)(ii)	2			2
14(a)		1	1	2
14(b)			1	1
15(a)	2	1		3
15(b)	2			2
16	1		3	4
17(a)	1	1		2
17(b)	2		2	4
18(a)(i)	3			3
18(a)(ii)	1			1
18(b)	2			2
18(c)	3			3
19(a)	3		2	5
19(b)		1		1
Totals	50	25	25	100